

## Parts Diagram

**Safety First!**

Use only Genuine Dualco Parts.  
Contact Dualco for repair, or rebuilding  
procedures.

Includes Models:  
11725 & 11660

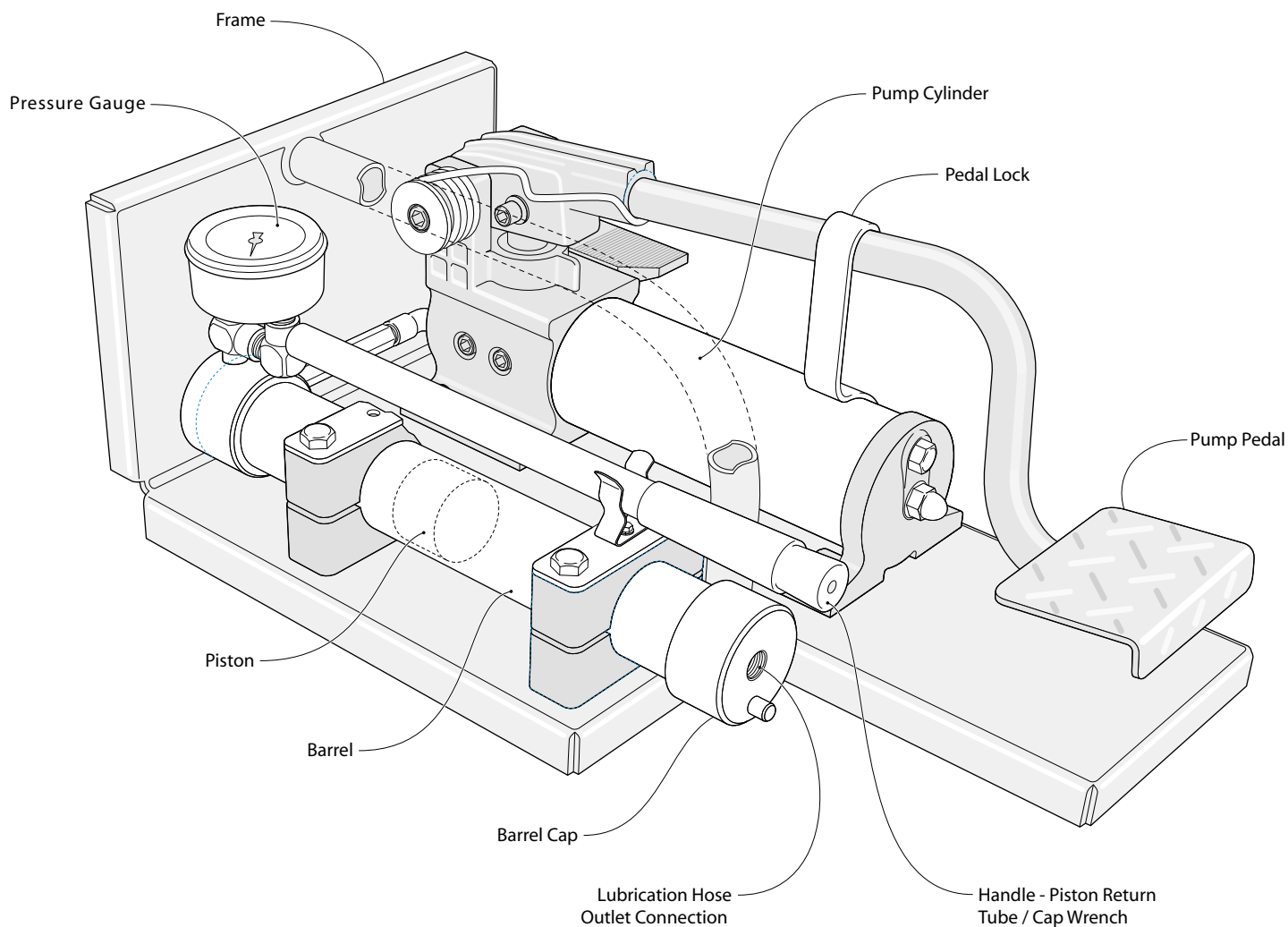
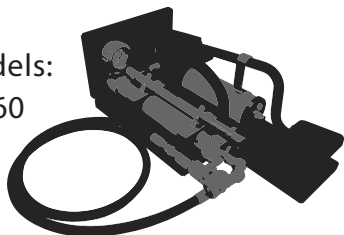

Read complete instructions  
before using this Gun.

### Part 1. Operation & Description

All models of the DUALCO Foot-Operated Hydraulic Injection Gun are high-pressure tools that should be used with caution and according to these instructions.

**IMPORTANT** - Do not exceed 10,000 psi for models 11660 and 11725.

These Injection Guns manually transmit material by the use of personal foot operation as a power source against pressurized hydraulic fluid.

During operation, the *Foot Pedal and Handle Assembly*, causes the *Plunger Assembly* to move in and out of the *Base*. As the *Plunger Assembly* goes into the *Base* it forces hydraulic fluid from the *Yellow Reservoir* through the *Base* and into the "K" *Barrel*. The pressurized Hydraulic Fluid forces the *Piston* inside the barrel forward, allowing grease to pump out the end of the hose. Other options are available for attachments to transmit material to the desired pump, valve, or other equipment. Be sure to have the appropriate material transmission apparatus or hose assembly firmly attached to *Grease Barrel Cap* before Gun operation.

To ensure the DUALCO Foot Operated Hydraulic Injection Gun will perform and operate properly, use after use, keep the gun out of the weather, clean and maintained.

### Part 2. Loading

Each new DUALCO Injection Gun is ready to use, following this procedure:

1. Make sure the gun is lying down horizontal. Depress the *Release Valve Pedal* with your right hand and twist the *Pedal Lock* towards the pedal with your left.
2. Now that the *Release Valve Pedal* is locked in position, stand the unit up vertical.
3. Turn the *Grease Barrel Cap* (with *Hose Assembly*) counter-clockwise from the *Barrel*. Remove completely.

### Part 2. continued

4. Remove the *Handle* from the *Clips* and push downward on the *Piston*, which is located inside the *Barrel*. Make sure the piston travels all the way down until it stops. The handle has a side hole near the threaded end, which will fit over the pin in the *Grease Barrel Cap*. Using the *Handle* in this manner makes it a convenient tool to loosen and tighten the *Cap*. The *Handle* is marked with approximate 1-ounce graduations for measuring material.

5. Load either a "J" or "K" Stick of Lubricant, Sealant or Packing in the *Barrel*.

6. Replace the *Grease Barrel Cap* (with *Hose Assembly*) and turn clockwise until tight.

**IMPORTANT** - Always make sure the *Grease Barrel Cap* is firmly attached to the *Grease Barrel*, and be sure there is full thread engagement between these two parts before each Gun operation.

7. Lay down the gun horizontal. With your right hand, depress *Release Valve Pedal* and twist the *Pedal Lock* away from the pedal with your left hand. This will allow the *Release Valve Pedal* to spring-up to a level "priming" position.

8. Place your foot on the square part of the *Foot Pedal and Handle Assembly* and apply pressure while sliding the *Handle Retainer* over to the left, releasing the handle.

9. Once again, place your foot on the *Foot Pedal and Handle Assembly* and continue pumping until a steady stream of product is discharged from the *Giant Button Head Coupler*.

10. Connect the *Giant Button Head Coupler* to the correct fitting and start to pump the *Foot Pedal and Handle Assembly* until the correct amount of product is injected.

11. Once your job is complete, turn the *Pressure Release tee handle* counter-clockwise one turn, releasing pressure from the *Giant Button Head Coupler*.

12. Remove the *Giant Button Head Coupler* from fitting and turn the *Pressure Release tee handle* clockwise one turn.

13. Coil-up your hose and store in the middle of the Gun Assembly.

To ensure the DUALCO Foot-Operated Hydraulic Injection Gun will perform properly, use after use, keep the gun out of the weather, clean, and well maintained.

**NOTE:** Prior to removing the Gun from operation, first make sure there is no back pressure.

### Part 3. Maintenance

- Any repair or service requiring disassembly of the DUALCO Foot-Operated Hydraulic Injection Gun must be performed in a dirt-free environment by a qualified DUALCO technician with proper instructions.
- Dispose of used parts, lubricants, and fluids properly. It is wise to use environmentally safe cleaning solvents.
- Be sure to contact DUALCO if there is ever an operational problem, or if there are any questions.

#### Item 1.

##### Injection Fluid

The DUALCO Foot-Operated Hydraulic Injection Gun comes filled with Enerpac hydraulic oil. Oil should be added or replaced as necessary using only Enerpac hydraulic oil. Do not contaminate or use any other fluid. Check the oil level in the Pump reservoir after every 10 hours of use. Drain and replenish the Pump reservoir with Enerpac hydraulic oil as specified. The oil is available in several size containers up to 55-gallon drums.



**WARNING** - Read Safety Data Sheet and DUALCO Injection Fluid label before use.

#### Item 2.

##### Refilling the DUALCO Foot-Operated Hydraulic Injection Gun with Injection Fluid and purging the system of air.

- During the first moments of operation or after prolonged use, air may accumulate within the system. This entrapped air may cause the cylinder to respond slowly or behave in an unstable manner. To remove the air, run the system through several cycles (extending and retracting the cylinder) free of any load. The cylinder must be at lower level than the Pump to allow air to be released through the Pump reservoir.
- Clean the entire area around the Pump filler plug before adding fluid to the Pump reservoir. Remove the Pump filler plug, and insert a clean funnel with filter. The cylinder must be fully retracted when adding fluid to the Pump reservoir.
- Refer to Enerpac Instruction Sheet.

#### Item 3.

##### Periodic Cleaning

**IMPORTANT** - The greatest single cause of failure in hydraulic pumps is dirt. Keep the Pump and attached equipment clean, to prevent foreign matter from entering the system.

- A routine should be established to keep the Pump as free from dirt as possible. All unused couplers must be sealed with thread protectors. All Hose connections must be free of dirt and grime. Any equipment hooked up to the Pump should also be kept clean.
- Use only Enerpac hydraulic oil in this Pump and change as recommended. Refer to Enerpac Instruction Sheet.

#### Item 4.

##### Draining and Flushing the Pump Reservoir



**IMPORTANT** - Wipe the Pump exterior completely clean before attempting this procedure. Refer to Enerpac Instruction Sheet.

- Drain and clean the other Hydraulic System components (hoses, cylinders, etc.) before reconnecting them to the Pump. This will prevent contaminated fluid from entering the Pump again.
- Warranty will be voided if the Pump Internal Relief Valve or other Gun components are altered, disassembled, or tampered with. Warranty will be voided if Gun is altered.



**WARNING:** Be familiar with all product and Pump warranties, maintenance-care procedures, and warnings before use.

- Always wear proper personal protective gear when operating equipment, such as safety glasses, gloves, hearing protection, etc. Do not disassemble this Gun, or warranty will be voided.

#### Note:

Contact DUALCO for technical assistance regarding other operation, repair, or rebuilding procedures.