

Level Measurement Expert

26GHz Pulse Radar Level Instrument

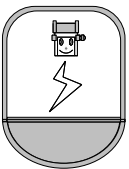
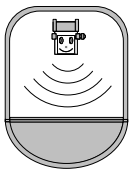
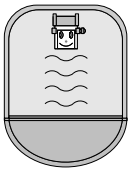

Silver Automation Instruments

Table of Contents

1 Measurement Principle	1
2 Product Overview.	2
3 Mounting Requirement.	5
4 Electrical Connection.	11
5 Adjustment Instructions.	14
6 Dimensional Drawings.	17
7 Technical Specifications.	20
8 Open Channel Flow	24
8 Selection & Ordering Information.	25
9 Application Questionnaire	33

1. Measurement Principle

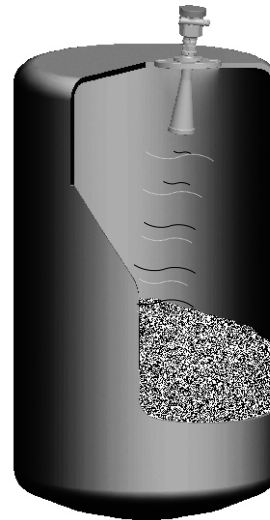

- Principle

The extremely narrow microwave pulse emitted by the antenna on radar level instrument can travel at the speed of light and part of its energy, which is reflected off the surface of target medium, is received by the very same antenna. The time lapse between pulse emission and reception by the antenna is proportional to the distance between the surface of target medium and the reference point on antenna. However, due to the fact that the electromagnetic wave is transmitted at extremely high speed, which leads to the tiny time lapse (nanosecond level) and makes it difficult to be identified, SDRD5X series of radar level instrument have adopted a special demodulation technology, enabling itself to detect the time lapse between pulse emission and reception correctly, and eventually generate accurate measurement result.

- Features

The guided wave radar level instrument, adopted 26GHz as transmission frequency, which make this series have specialties as below: Small beam angle, which centralize energy, make SDRD5X high ability of anti-jamming, hence high accuracy and reliable. Small antenna size, easy to mount and easy to equip extra dust protection Small blind zone, good accuracy even for small vessels. Shorter wave-length, suitable for small power.

Equipped with advanced microprocessor and unique EchoDiscovery echo processing technology, the radar level instrument can be used under various hazardous process conditions

The guided wave radar level instrument, with pulses as its working tool and extremely low emission power, can be mounted on various metal or nonmetal vessels, harmless towards the environment and human beings.

2 Product Overview

SDRD55



SDRD56



Application:	Liquid Level measurement in liquids, especially highly erosive liquids	Liquid Level measurement in liquids, under certain temperature and pressure, mildly erosive liquids
Max Measurement Range:	10m	30m
Measurement Accuracy:	±5mm	±3mm
Process Temperature:	(-40~130)° C	(-40~80)° C (-40~130)° C (-60~250)° C (-60~400)° C
Process Pressure:	(-0.1~0.3)MPa	Normal (-0.1~4)MPa (-0.1~40)MPa
Frequency Range:	26GHz	26GHz
Signal Output:	(4~20)mA/HART	(4~20)mA/HART
Power:	2-wire (DC24V) 4-wire (DC24V/AC220V)	2-wire (DC24V) 4-wire (DC24V/AC220V)
LED:	Optional	Optional
Housing:	A/B/C/D ¹ (Refer to page 4)	A/B/C/D ¹
Process Connection:	F	G/H/I/J/K ²
Flange Accessories:	L	L/M/N/P ³
Antenna:	R	S/T/V ³

Notes:

- 1、Intrinsically Safe couldn't use "A"
- 2、Huff must use antenna "T", process Connection must use "I"; High temp. Process Connection must use "J" "K"

SDRD57



SDRD58



SDRD59



Liquid
Level measurement of highly erosive medium under certain pressure/temperature limit and suitable for 20m
±3mm

(-40~150)° C

(-0.1~0.5)MPa

26GHz
(4~20)mA/HART
2-wire (DC24V)
4-wire (DC24V/AC220V)

Optional

A/B/C/D¹

U

Solid
strong dew/dust/crystal

70m
±15mm

(-40~80)° C
(-40~120)° C
(-60~250)° C
(-60~400)° C

Normal
(-0.1~4)MPa
(-0.1~40)MPa

26GHz
(4~20)mA/HART
2-wire (DC24V)
4-wire (DC24V/AC220V)

Optional

A/B/C/D¹(See the page4)

G/H/I/J/K²

L/M/N/P³

S/T/V³

Solid
Normal Temperature/Normal Pressure

15m
±10mm

(-40~80)° C

Normal

26GHz
(4~20)mA/HART
2-wire (DC24V)
4-wire (DC24V/AC220V)

Optional





A/B/C/¹

G







L/M/N

S





● Housing

				
Serial number	A	B	C	D
Material	Plastic	Aluminum Alloy	Aluminum Alloy (Two-chamber)	Stainless steel (316L)
Specialty		Economic Suitable for explosion-protection	(Intrinsically safe + Flameproof Approval)	Ship Approval





● Process Connection

						
Serial number	F	G	H	I	J	K
Material	PTFE	PP	Stainless Steel	Stainless Steel (Huff)	Stainless Steel	Stainless Steel Flange
Pressure	(-0.1~0.3) MPa	Normal Pressure	(-0.1~4) MPa	(-0.1~0.5) MPa	(-0.1~4) MPa	(-0.1~40) MPa
Temperature	(-40~130) °C	(-40~80) °C	(-60~150) °C	(-60~130) °C	(-60~250) °C	(-60~400) °C

● Flange Accessories

				
Serial number	L	M	N	P
Material	(PTFE/PP) Flange	Stainless Steel Flange	PP Gimbal Flange	Stainless Steel Gimbal Flange
Specialty	Rust tolerated	High temp./High Pressure	Normal Temperature/Normal Pressure	High temp./Normal Pressure

● Antenna

					
Serial number	R	S	T	U	V
Material	PTFE	PP (PTFE shield)	Stainless Steel	PTFE	Stainless Steel (PTFE shield)
Specification	Φ 44/Length137 Φ 44L/Length237	Φ 98/Length280 Φ 98L/Length440	Φ 48/Length140 Φ 78/Length227 Φ 98/Length288 Φ 98L/Length474 Φ 123/Length620	DN50/ DN80/ DN100	Φ 98/300 Φ 98L/480 Φ 123/625
Specialty	Rust tolerated	Normal Temperature/Normal Pressure	Temperature tolerated/Pressure tolerated	Rust tolerated/Pressure tolerated	Normal Temperature/Normal Pressure

3. Mounting Requirements

- Basic Requirements

There is a certain existing beam angle while the antenna transmitting microwave pulses. There should be no barriers between the lower edge of antenna and surface of measured medium. Therefore it is highly recommended to avoid facilities inside vessels, such as ladders, limit switches, heating spirals, struts and etc, during the mounting process. "False echo learning" must be carried out during the installation in this case. Furthermore, microwave beams must NOT intersect the filling streams. Be cautious during the installation: the highest level of target medium must NOT enter into blanking zone; the instrument must keep certain distance to vessel walls; every possible measure needs to be taken to position the instrument so that the direction of antenna emission is perpendicular to the surface of measured medium. The installation of instruments in explosion proof area must abide by relevant local or federal safety regulations. Aluminum housing should be used for intrinsically safe explosion proof version, which is also applicable in explosion proof areas. The instrument must be connected with ground in this case.

- Illustrations

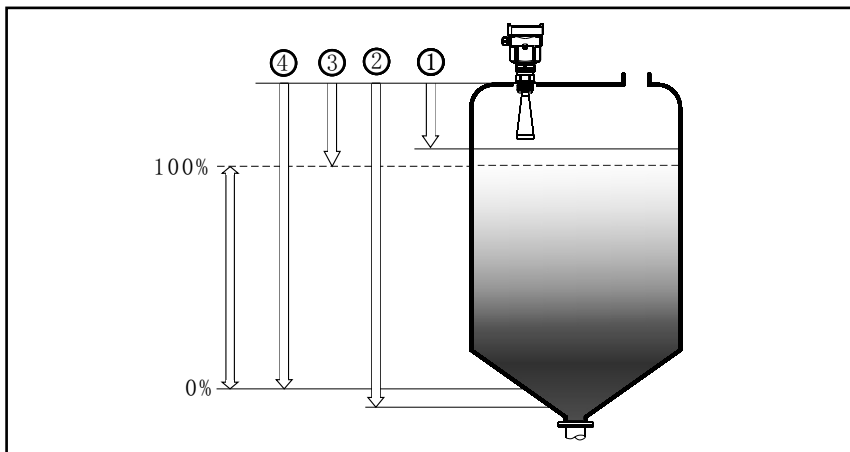

The reference plane is the thread or flange surface

1. Blanking Zone(menu1.9)
2. Empty(menu1.8)
3. Max. Adjustment(menu1.2)
4. Min. Adjustment(menu1.1)

Note: The highest level of measured medium must not enter into blanking zone while radar level measurement instrument is in operation.

- Mounting Position

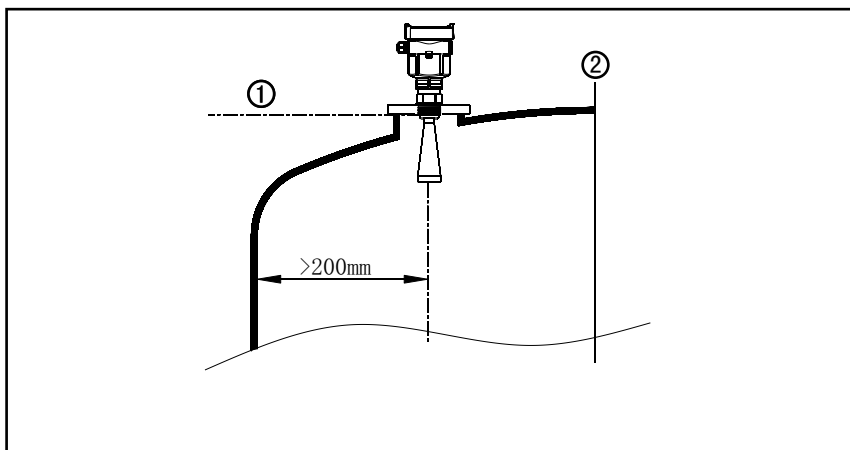

Minimum distance of 500mm between instrument and vessel wall during installation

1. Reference Plane
2. Center of Vessel or Symmetrical Axis

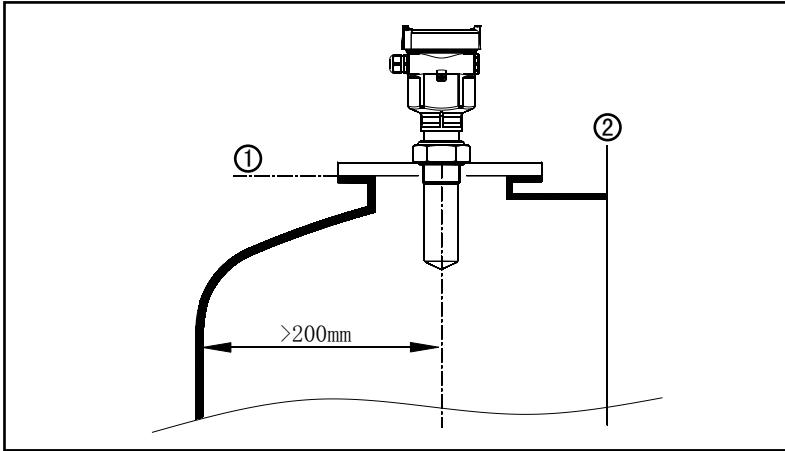

- 1. Reference Plane
- 2. Center of Vessel or Symmetrical Axis

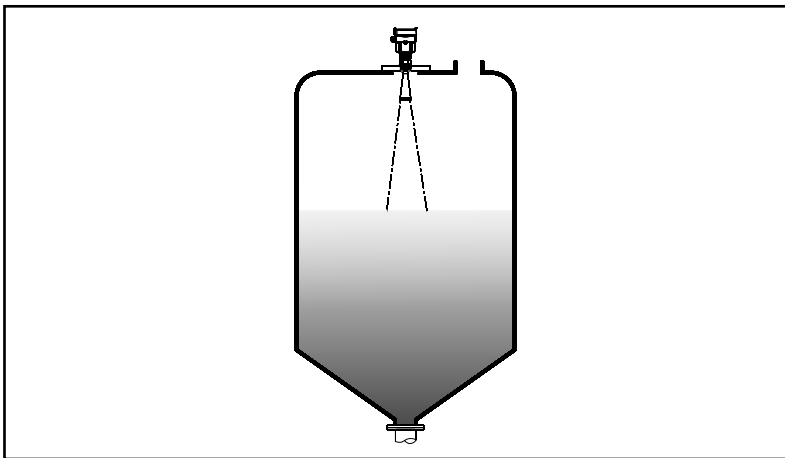

The best mounting position for a conical vessel with flat top is the center of its top, as the effective measurement can reach the bottom of vessel.

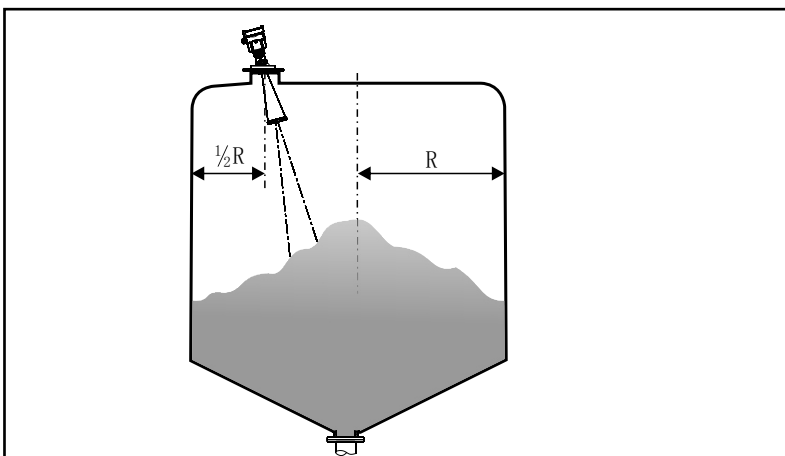

Installation with Gimbal

- Damp-proof

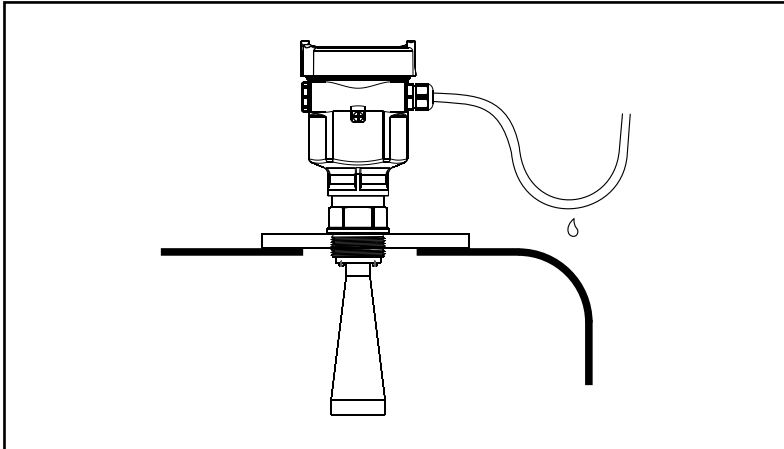

In order to avoid dampness under outdoor or humid indoor conditions or for those instruments mounted on cooling/heating vessels, seal rings used on cables should be screwed tight, plus the cable must be bended downward outside cable entry, indicated on the diagram below

- Antenna Extension

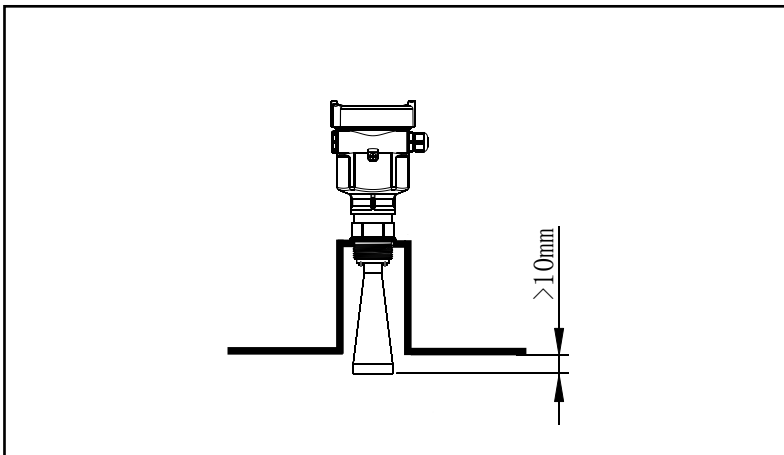

The transducer end must at least protrude 10mm out of socket.

SDRD56 Antenna Extension

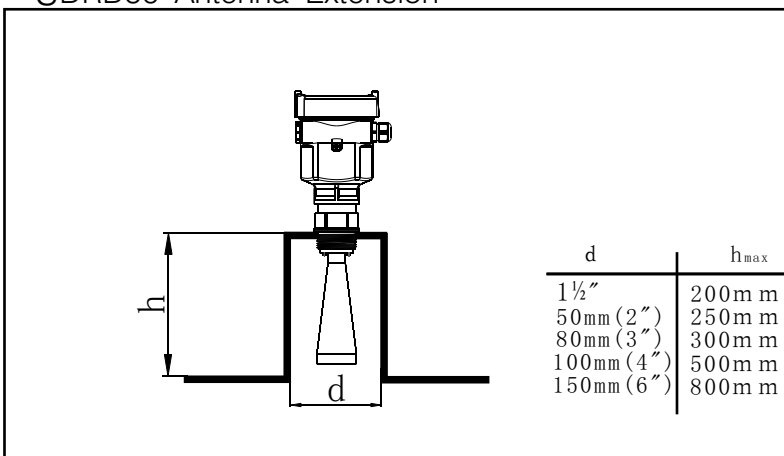

If the senser is mounted in a socket extension that is too long, strong false echoes are generated which interfere with the measurement. Make sure that the horn antenna protrudes out of the socket piece.

● SDRD57 Connecting Pipe Diagram

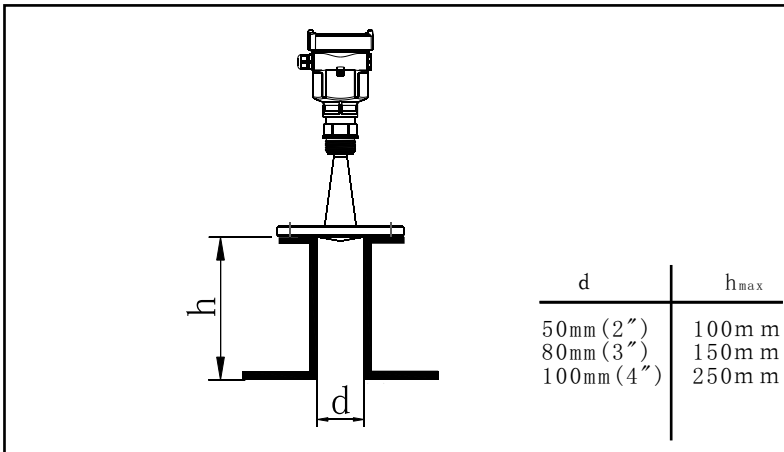

● Rights and Wrongs in Mounting

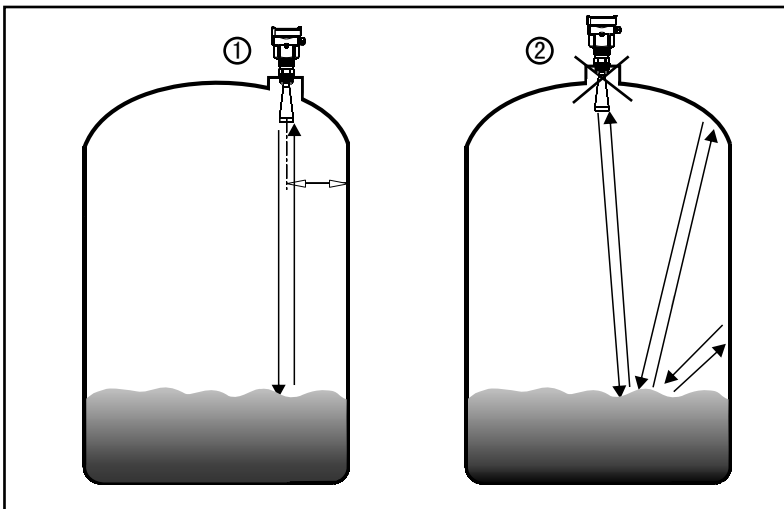

1. Correct
2. Wrong: Instruments are mounted in the center of concave or arched vessel tops, which results in multiple echoes.

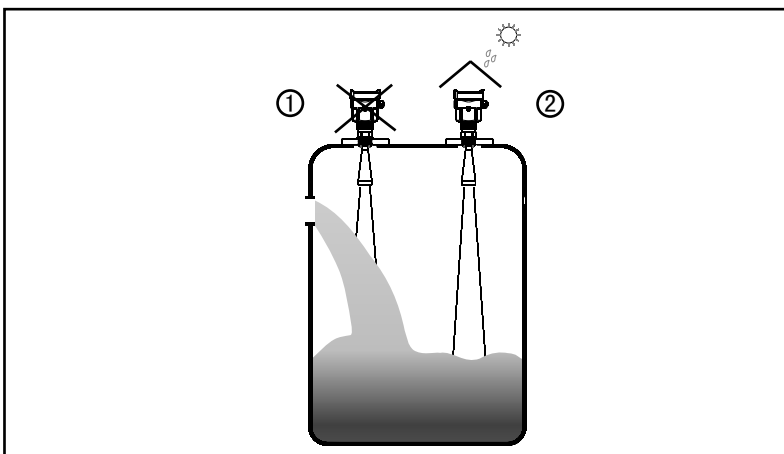

1. Wrong: Mount the instrument in/above filling stream, which results in the measurement of filling stream not the target medium.
2. Correct:

- Reflector Mounting

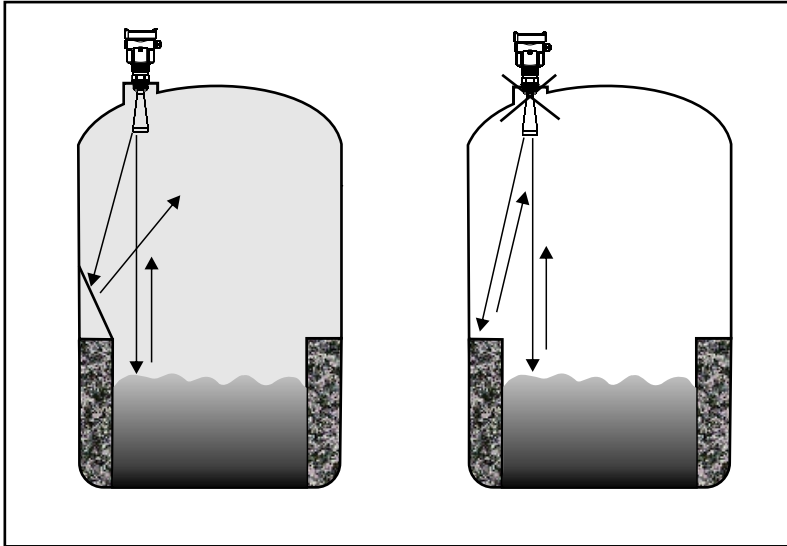

If there are barriers in vessels, it is required to mount baffle-board, by doing this, the echo reflected by the barrier will be reflected out. And "False Echo Storage" will be applied.

- Agitator

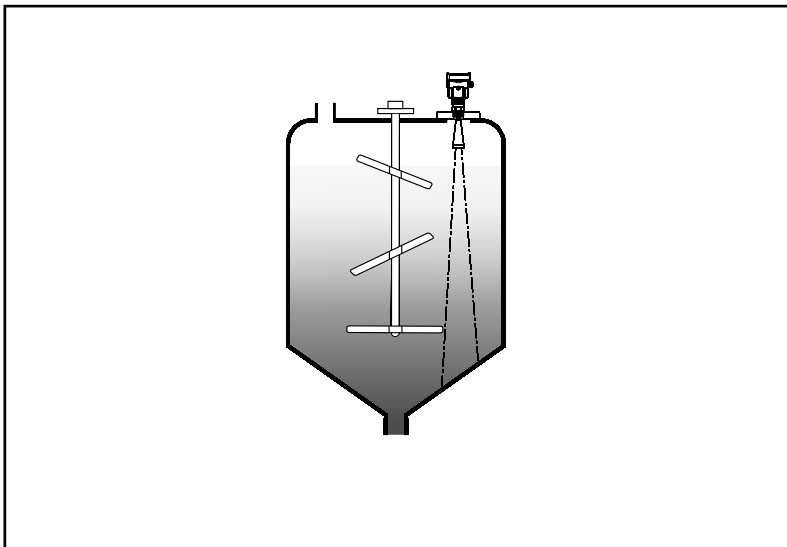

If there are agitators in vessels, instrument must be mounted as far away from agitators as possible. Once installation completed, a "false echo learning" should be carried out while agitators in motion to eliminate negative influence caused by false echo of agitators. You are advised to opt for installation with standpipe if foam or wave is generated due to the action of agitators.

- Installation with Standpipe

By using standpipe, the influence of foams can be reduced.

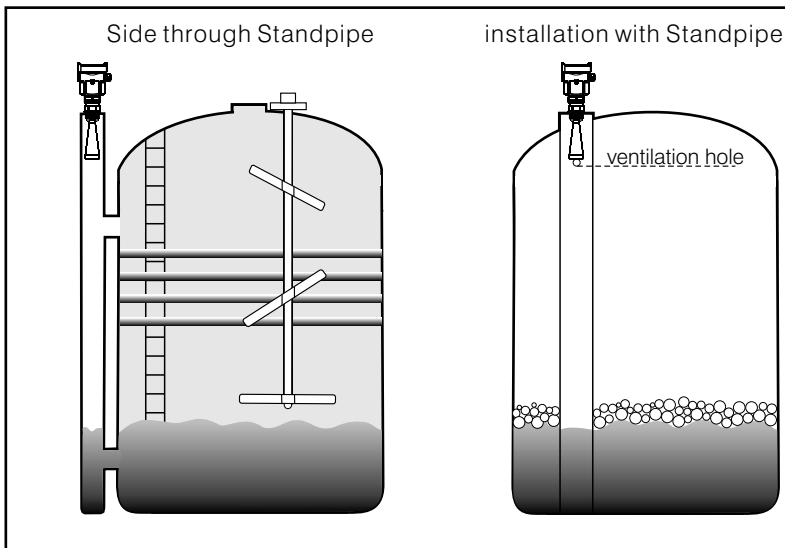

You are advised to opt for installation with standpipe (or bypass tube) to avoid the influence on measurement caused by barriers inside vessels or foam generation.

It is advised to install antenna inside of the standpipe to avoid the error caused by foam. The minimum inner diameter of standpipe should be 50mm. Avoid large cracks or welding seam when connecting standpipe. False echo storage must be carried out as well in this case.

Note: You must NOT mount instrument inside standpipe while measuring adhesive medium.

4 Electrical Connection

● Power Supply

20mA/HART(2-Wire) Power supply and current signal are carried by the same two-wire connection cable. See the Technical Specifications of this guide for detailed requirement on power supply. A safety barrier should be placed between power supply and instrument for intrinsically safe version.

20mA/HART(4-wire) Power supply and current signal are carried by two 2-wire connection cables respectively. See the Technical Specifications of this guide for detailed requirement on power supply. Earth-connected current output can be used for standard version of level instruments, while the explosion proof version must be operated with a floating current output. Both instruments and earth terminals should be connected with ground firmly and securely. Normally you can either choose to connect with the earth terminal on vessel or adjacent ground in case of plastic vessels.

● Cable Connection

General Introduction

4~20mA/HART

Standard 2-wire cable with outside diameter of 5...9mm, which assures the seal effect of cable entry, can be used as feeder cable. You are recommended to use screened cables in the event of electromagnetic Connection cable with special earth wire can be used as feeder cable.

Connection cable with special earth wire can be used as feeder cable.

20mA/HART(4-wire)

Shielding & Grounding

The two ends of shielded cable must be connected with earth terminal. The shielded cable must be connected with inner earth terminal directly inside the transducer, while the outside earth terminal on housing must be connected with ground. In the event of earth-connected current, the shielding side of shielded cable must be connected to ground potential via a ceramic capacitor (e.g. : 1 μ F 1500V) in order to dampen the low frequency grounding current and avoid the disturbance caused by high frequency signals

● Wiring Diagram

2-wire

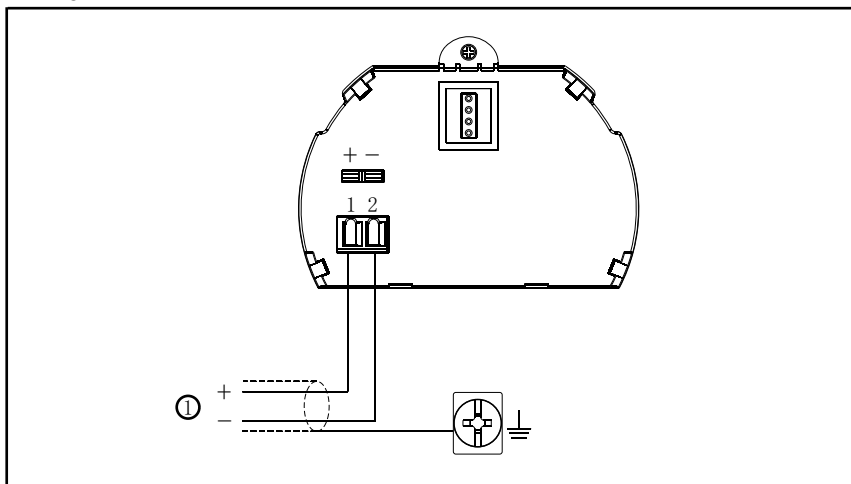

2-wire wiring used for HART

1) Power Supply and Signal Output

4-wire/2-chamber

Wiring Diagram: 200V AC Power Supply, 4...20mA Signal Output

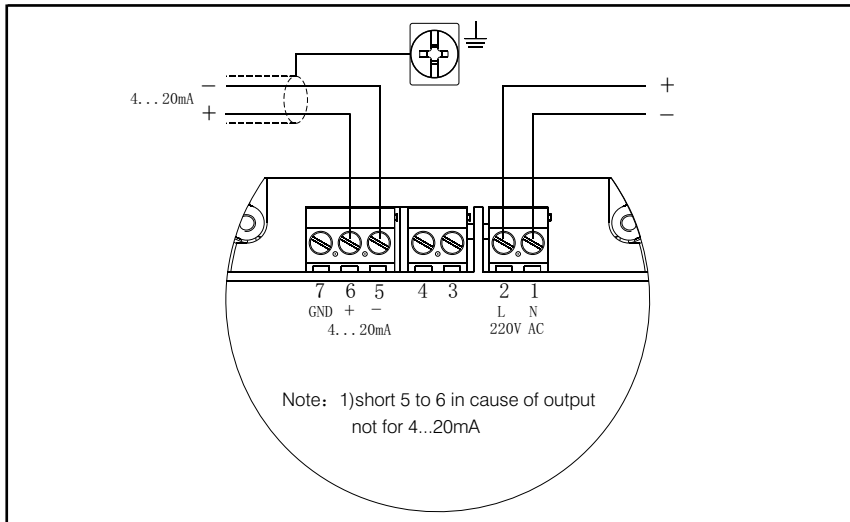

Wiring Diagram: 4-wire 24V DC Power Supply, 4...20mA Signal Output

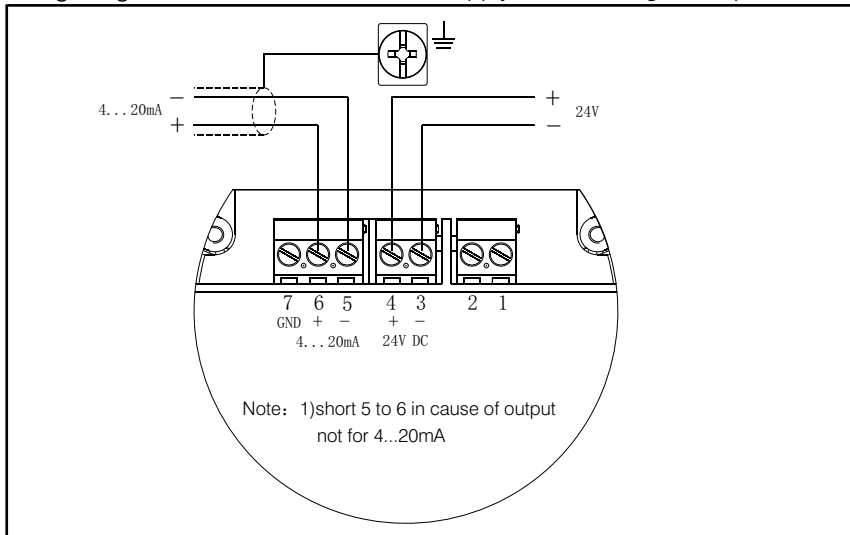

Wiring Diagram: dual-wire 24V DC Power Supply, 4...20mA Signal Output

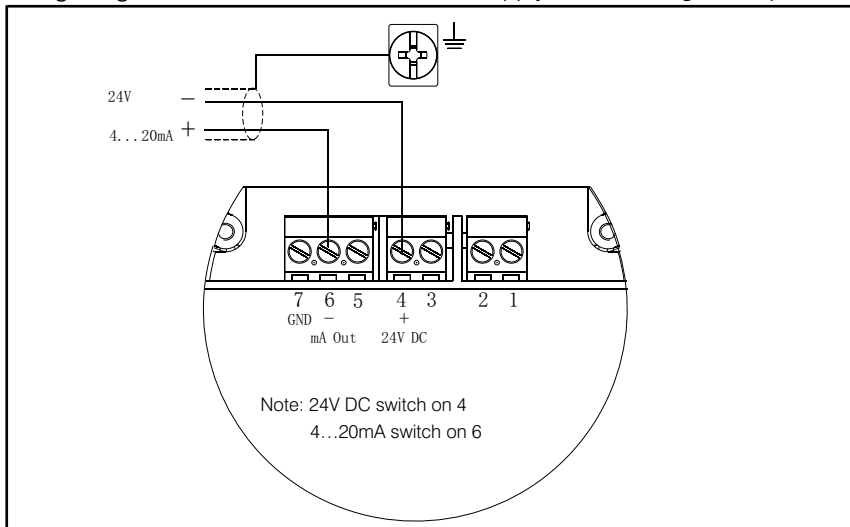

- Explosion Proof Connection

This product is an intrinsic safety explosion proof version (Exia II C T6) with aluminium housing and plastic-encapsulated internal structure aimed to prevent sparks resulted from transducer and circuit malfunction from leaking out. It is applicable for the non-contact continuous level measurement of flammable medium under the level of explosion proof inferior to Exia II c T6. You are required to use FBS-2 series (intrinsic safety explosion proof: [Exia] II C, voltage of power supply: 24V DC \pm 5%, short-circuit current: 135mA, operating current: 4...20mA) of safety barriers, which are supplementary to this product, for the power supply of this product.

All connection cables must be screened with max. length of 500m. Stray capacitor \leq 0.1 μ F/Km, stray inductance \leq 1mH/Km. The level measurement instrument must be connected to ground potential and unapproved supplementary devices are not allowed to use.

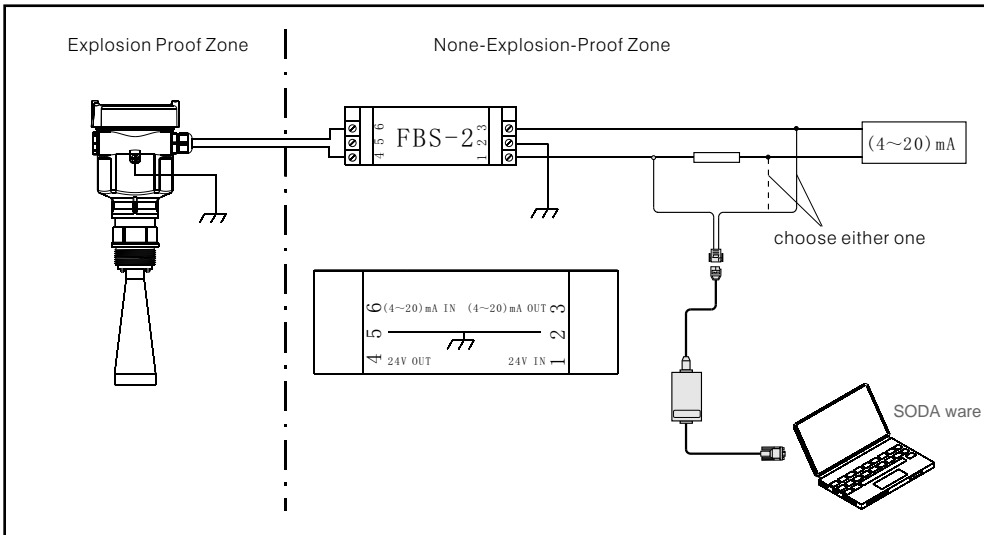

Adjust with SODAware

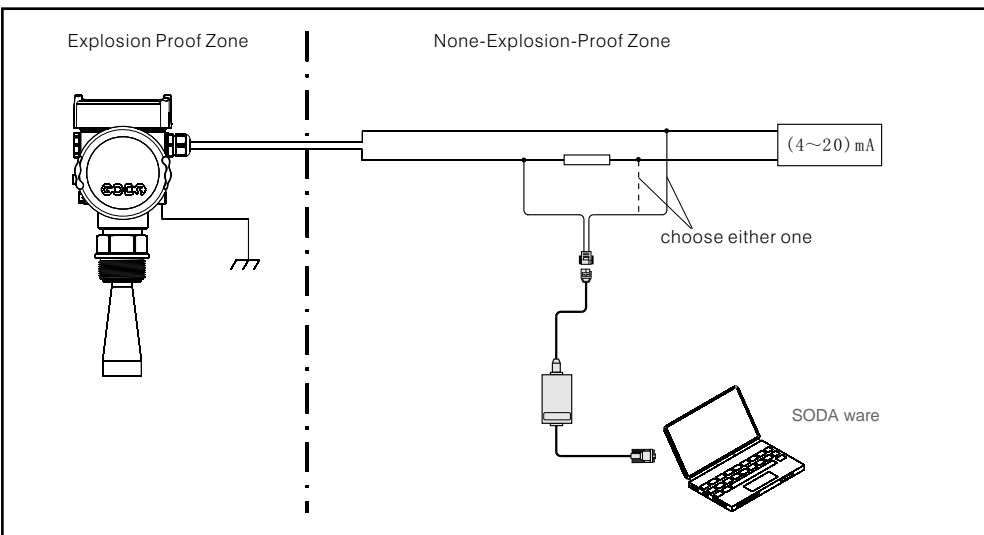

Adjust with Intrinsically Safe+Flameproof Approval

5 Adjustment Instructions

● Adjustment Methods

Three adjustment methods available for SDRD5X:

1. Display/Adjustment Module
2. Adjustment software SODAware
3. HART handheld programmer

ViewPoint is a pluggable display/adjustment module. The adjustment can be done through operating with four buttons on ViewPoint. Optional menu operation languages are available for selection. ViewPoint is only used for display after adjustment in that the measurement results can be seen clearly through the glass window.

Display/Adjustment Module

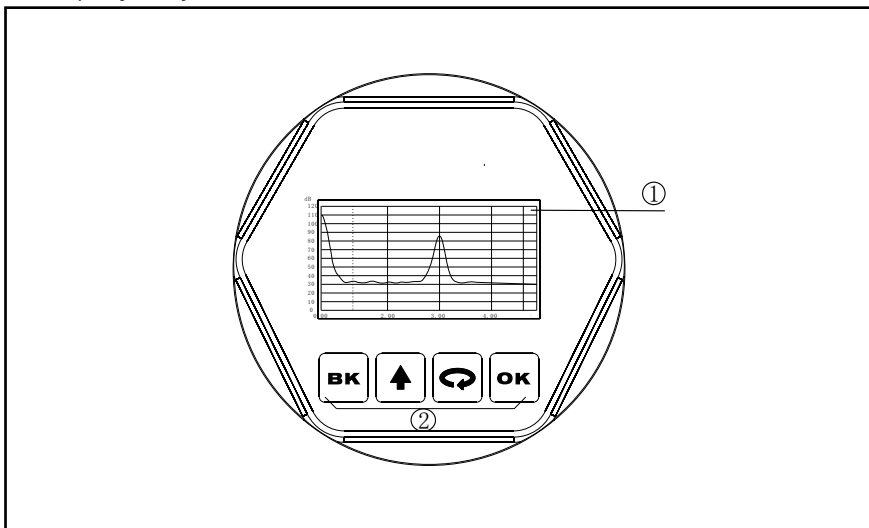

1 LCD 2 Adjustment Keypad

[OK] Keypad

- Enter programming mode;
- Confirm programming options;
- Confirm modifications to parameters.

[↻] Keypad

- Choose programming options;
- Choose the digit of parameters to edit;
- Display the contents of parameters.

[↑] Keypad

- Modify parameter values.

[BK] Keypad

- Programming mode exit;
- Return to higher menu level.

Shortcut

[BK] Display Echo wave

• SODAware

Connect with another unit through HART.

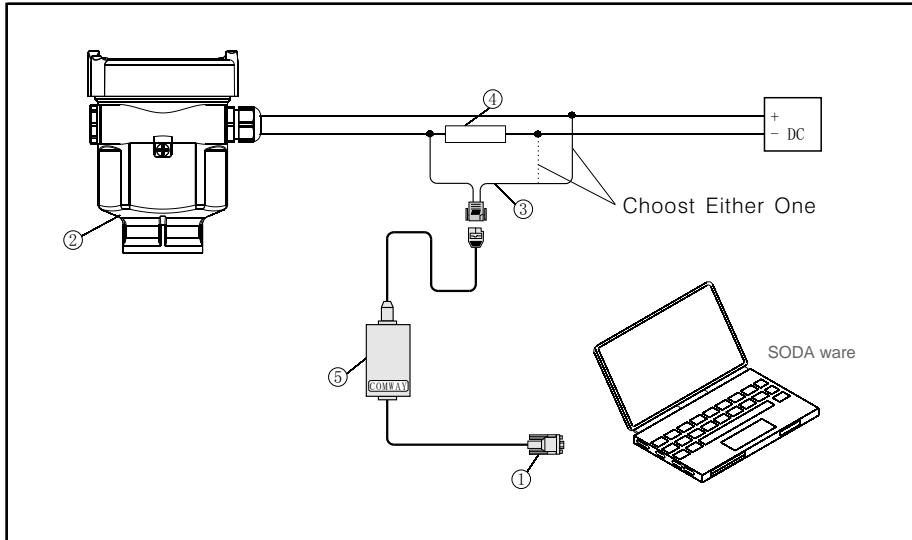

- 1 RS232 Connect Cable/USB port
- 2 SDRD5X
- 3 HATR pont adapter used on COMWAY convertor
- 4 250 ohm Resistance
- 5 COMWAY Convertor

Connect with another unit through I²C.

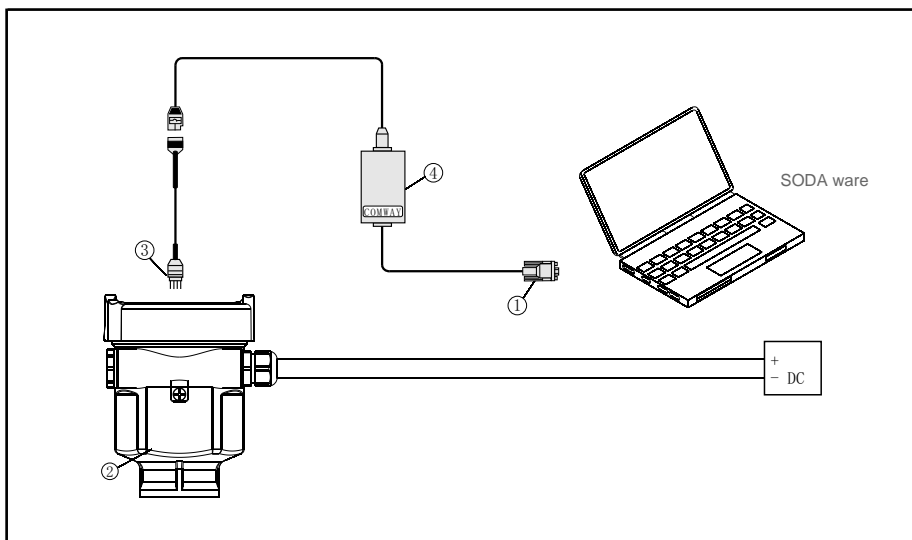

- 1 RS232 Connect Cable/USB port
- 2 SDRD5X
- 3 I²C adapter pont used on MOMWAY convertor
- 4 COMWAY Convertor

HART Handheld Programmer

Adjust SDRD5X with HART Handheld Programmer

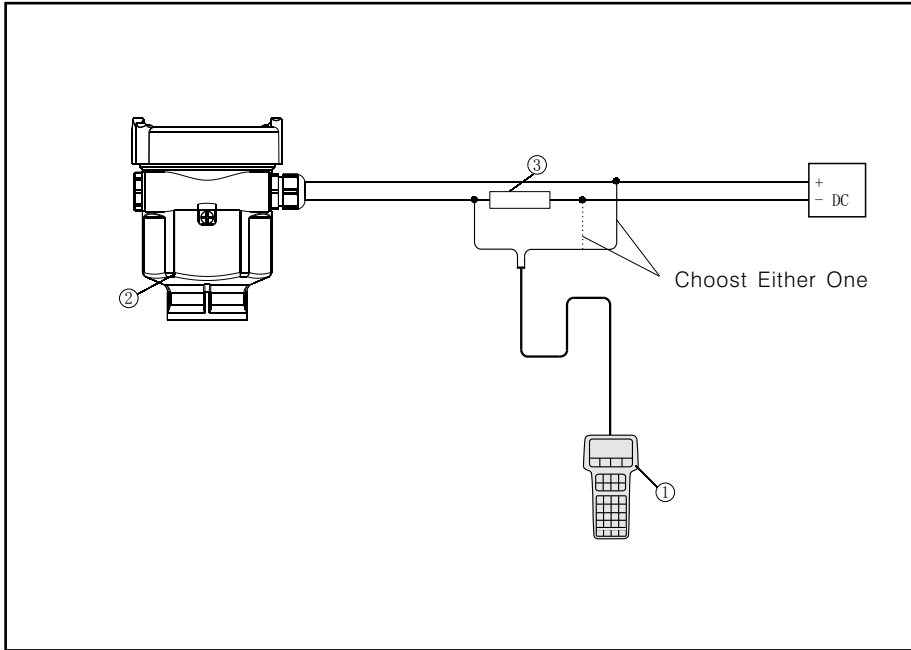

- 1 HART Handheld Programmer
- 2 SDRD5X
- 3 250 ohm Resistance

6 Dimension (Unit: mm)

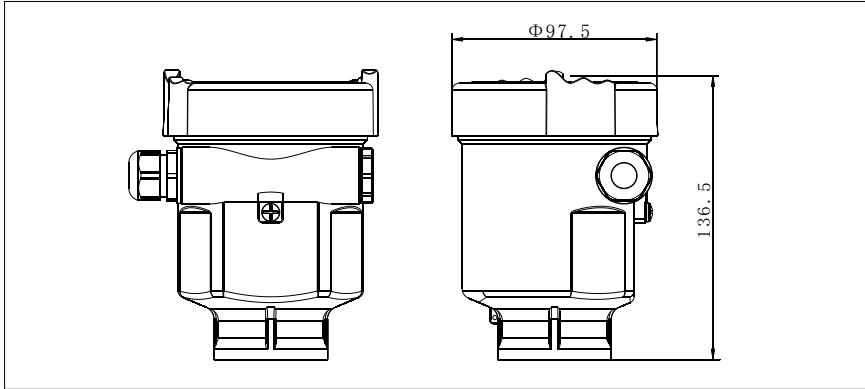

Housing
Material: PBT/AL/316L

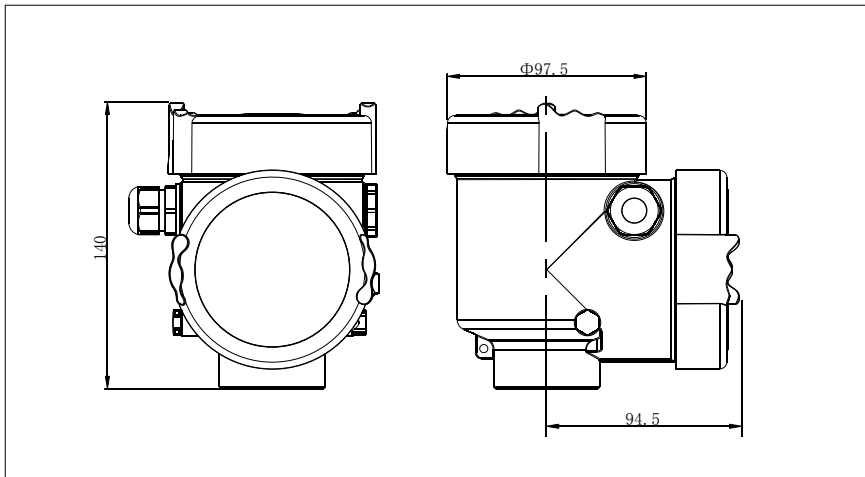

Material: two-chamber

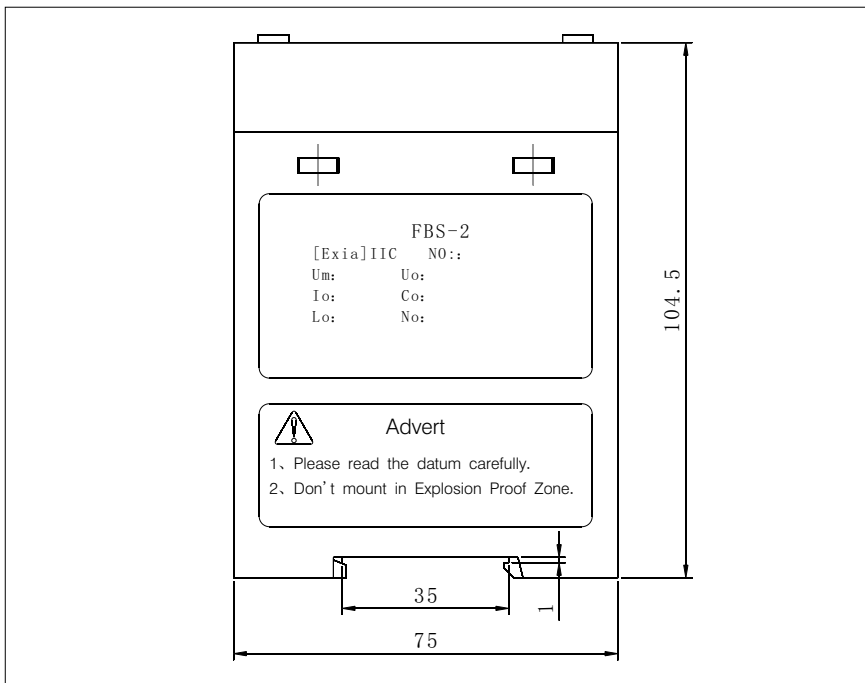

FBS Series

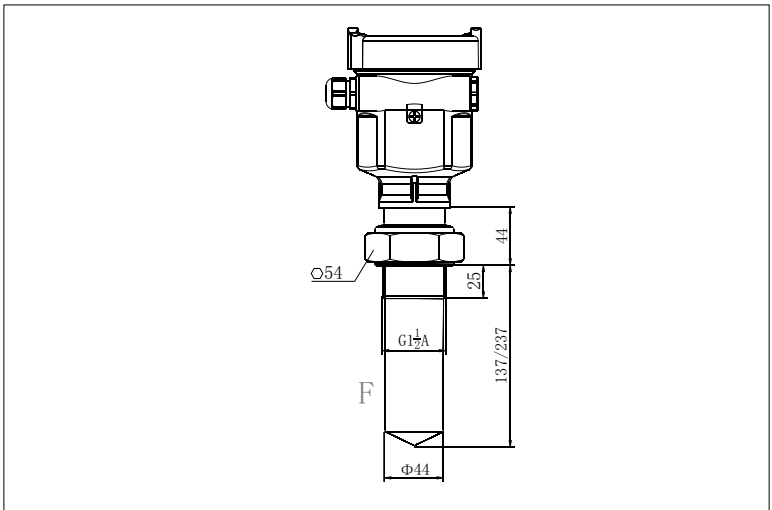

SDRD 55 Threaded Vision

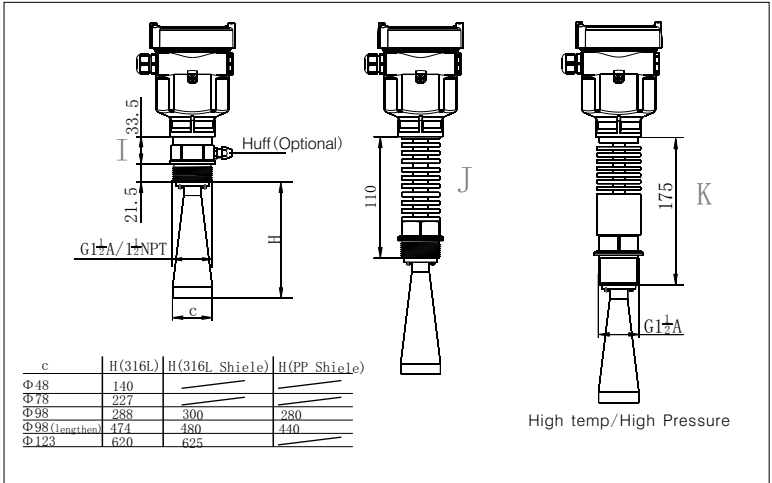

SDRD 55 Threaded Vision

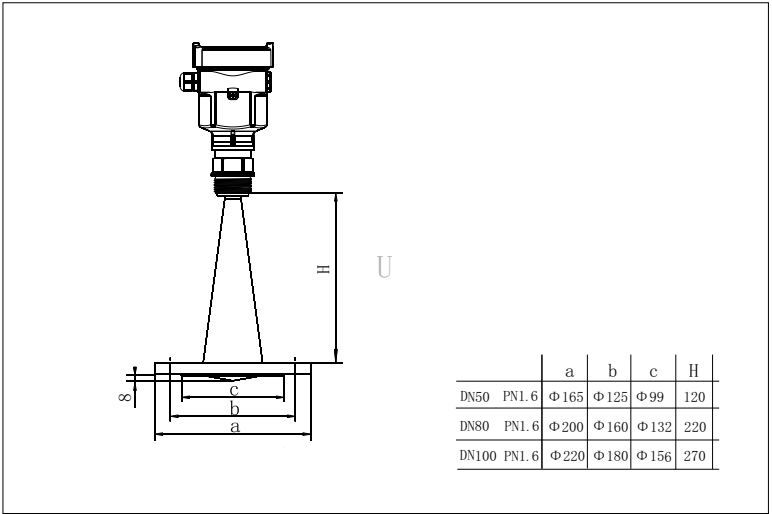

SDRD 57 Flange Vision

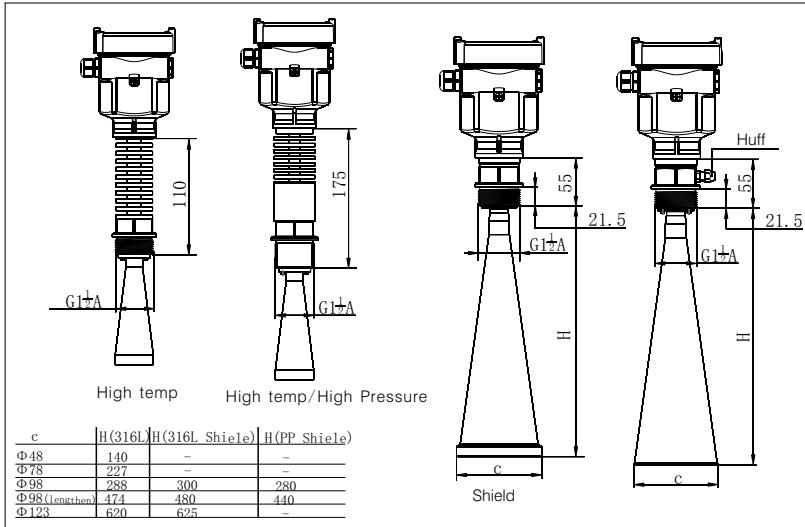

SDRD 58 Threaded Vision

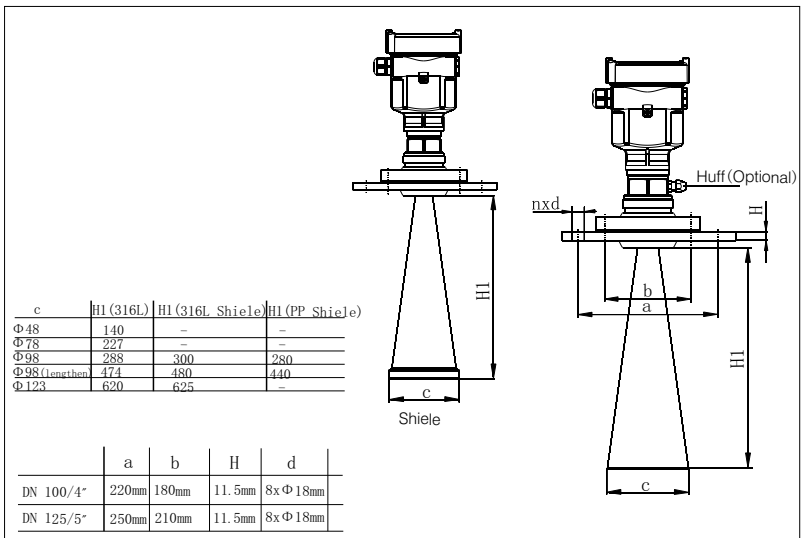

SDRD 58 Gimbal Flange

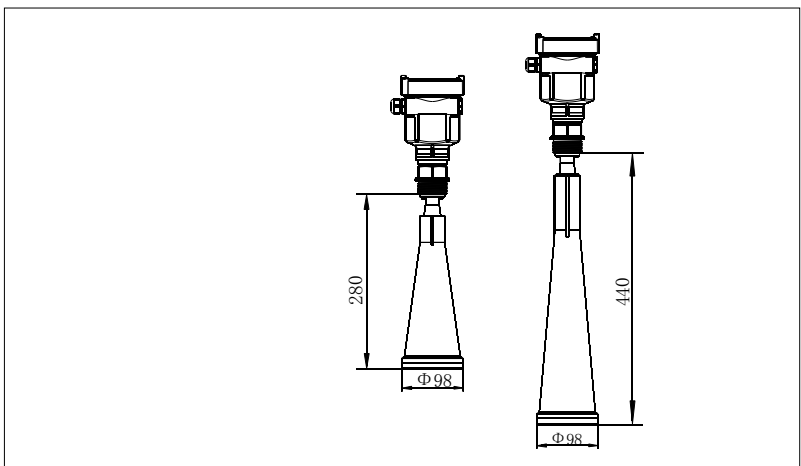

SDRD 58

7 Technical Specifications

● General Parameters

产品型号	SDRD55	SDRD56	SDRD57	SDRD58	SDRD59
Process Connection	ThreadG1½A	ThreadG1½A		ThreadG1½A	
		Thread1½NPT	Flange 316L	Flange 316L	
				Thread1½NPT	
Material	PTFE	Stainless Steel 316L PTFE	PTFE	Stainless Steel316L PTFE	PTFE

Housing Plastic PBT-FR; Aluminium,Stainless Steel 316L
 Seal ring between housing and housing cover Silicone
 ViewPoint window on housing Polycarbonate
 Ground terminal Stainless Steel

Weight

Weight

- SDRD55 1kg (Depend on process connections and housings)
 - SDRD56 2kg (Depend on process connections and housings)
 - SDRD57 3kg (Depend on process connections and housings)
 - SDRD58 7kg (Depend on process connections and housings)
 - SDRD59 2kg (Depend on process connections and housings)

Power 2-wire

Standard Version (16~36)V DC
 Intrinsic Safe Version (21.6~26.4)V DC
 Power Consumption max.22.5mA
 Ripple Allowed
 - <100Hz U_{ss}<1V
 - (100~100K)Hz U_{ss}<10mV

4-wire/2-chamber

Intrinsic Safe+Explosion-Proof (22.8~26.4)V DC, (198~242)V AC
 Power Consumption max.1VA, 1W

Parameters on Cable

Cable Entry/Plug One cable entry of M20x1.5 (cable diameter of 5~9mm) ,
 one binding of M20x1.5
 Spring Connection Terminal Applicable for cables with cross section of 2.5mm²

Output

Output Signal 4...20mA/HART
 Resolution 1.6μA
 Fault Signal Constant current output: 20.5mA;
 22mA; 3.9mA
 -2-wire load resistance See diagram below
 -4-wire load resistance Max. 500ohm
 Integration Time 0...40sec, adjustable

2-Wire Load Resistance Diagram

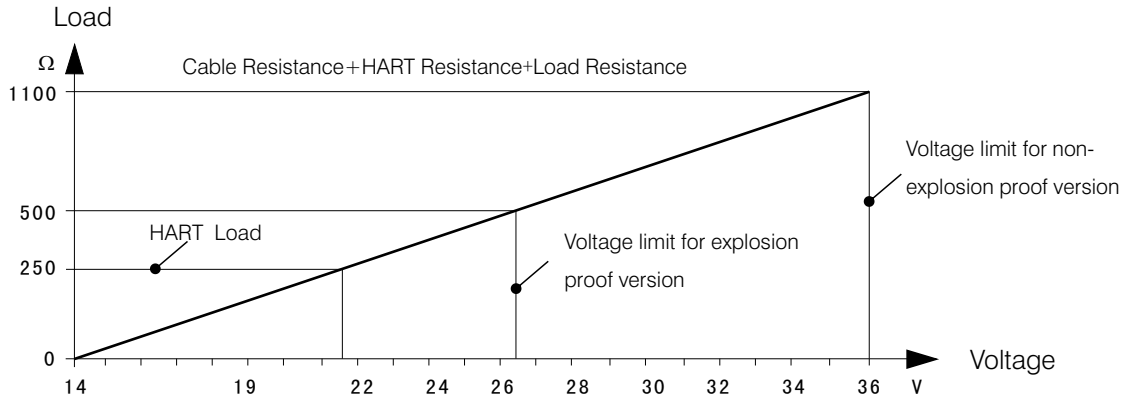

● Characteristic parameter	Blanking Distance	End of Antenna
	Max Measurement Distance	<ul style="list-style-type: none"> - SDRD55 10m (liquid) - SDRD56 30m (liquid) - SDRD57 20m (liquid) - SDRD58 70m (solid) - SDRD59 15m (solid)
	Microwave Frequency	26GHz
	Measurement Interval	About 1sec (Depend on parameter settings)
	Adjustment Time ¹⁾	About 1sec (Depend on parameter settings)
	Resolution of Display	1mm
	Accuracy	See the diagram below
	Temperature for Storage/Transport	(-40~100)°C
	Process Temperature (Probe)	
		- SDRD55 (-40~130)°C
		- SDRD56 (-60~400)°C
		- SDRD57 (-40~150)°C
		- SDRD58 (-60~400)°C
		- SDRD59 (-40~80)°C
	Relative Humidity	<95%
	Pressure	Max. 40MPa
	Vibration Proof	Mechanical vibration 10m/s 10m ² /s , 10~150Hz

SODA 55

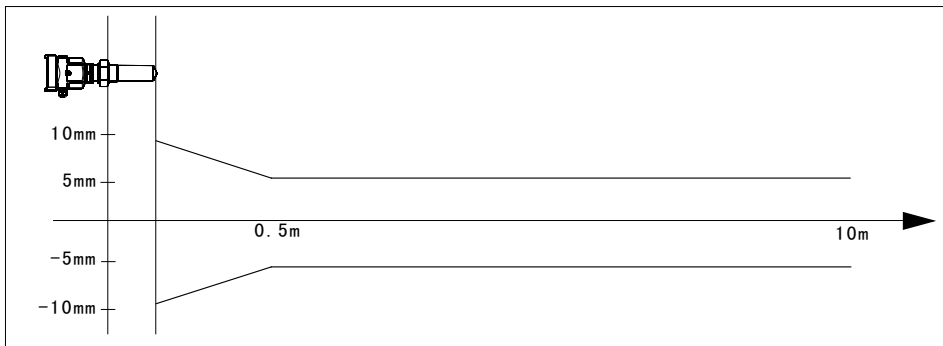

3dB Beam Angle 22°
Accuracy See the diagram left

1) The generation of accurate measurement results needs longer time than usual in the event of drastic level changes(mx. Error 10%).

SDRD56

3dB Beam Angle

- Φ 48mm 18°
- Φ 75mm 12°
- Φ 98mm 8°
- Φ 123mm 6°

Accuracy

See the accuracy illustration diagram below

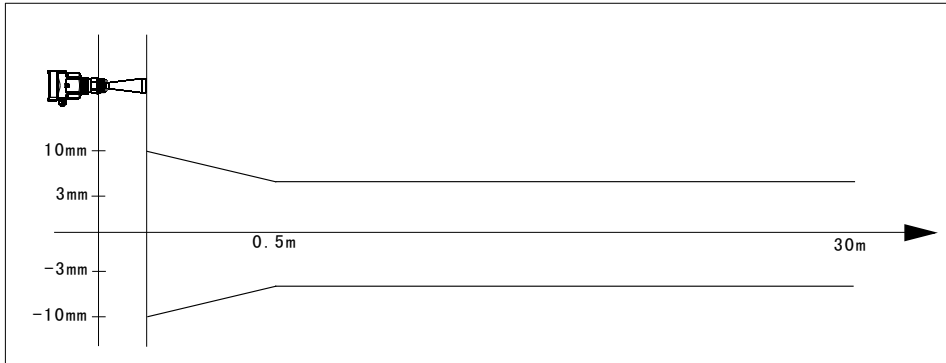

SDRD57

3dB Beam Angle

- flange DN50 18°
- flange DN80 12°
- flange DN100 8°

Accuracy

See the accuracy illustration diagram below

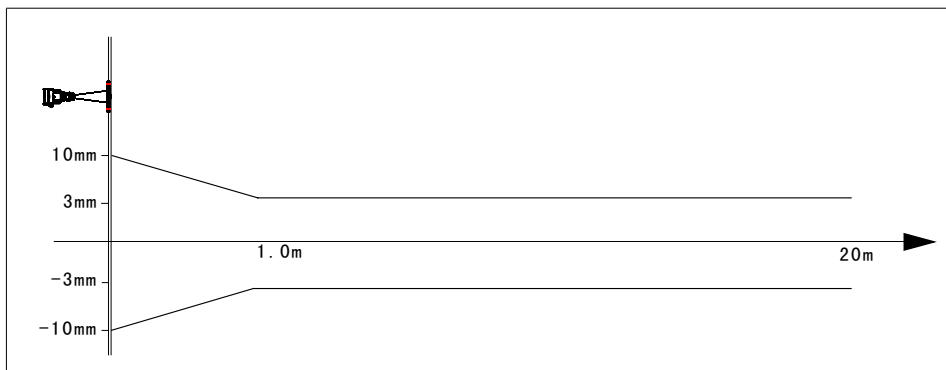

SDRD58

3dB Beam Angle

- Φ 48mm 18°
- Φ 75mm 12°
- Φ 98mm 8°
- Φ 123mm 6°

Accuracy

See the accuracy illustration diagram below

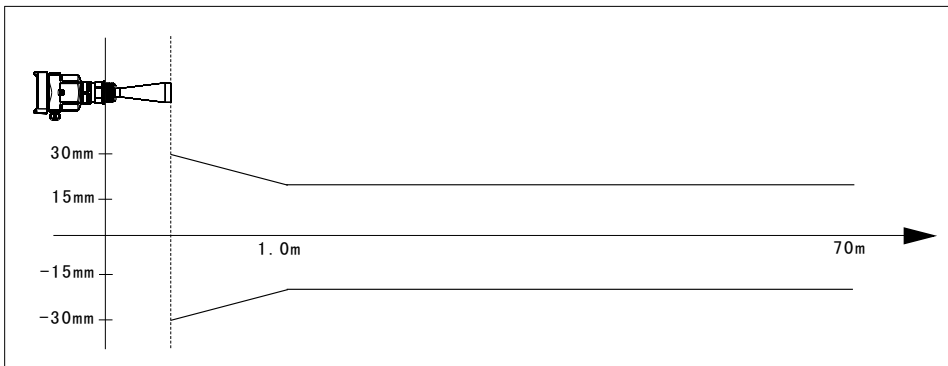

SDRD59

3dB Beam Angle

- Φ 98mm

8°

Accuracy

See the accuracy illustration diagram below

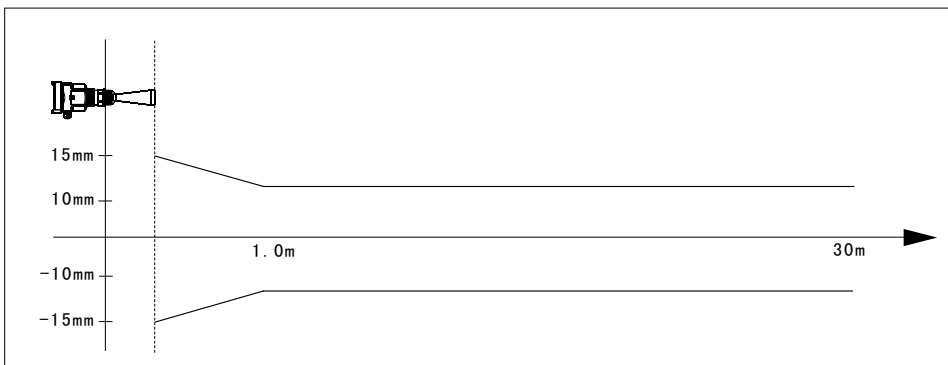

8 明渠流量

物位计用于明渠流量的测量

根据国家计量检定规程之《明渠堰槽流量计（JJG-1990）》（以下简称“规程”）的规定，在明渠中放置规程中规定的各类堰槽，利用物位计测量明渠堰槽中液面高度，可换算出液体的流量。（下图为溢流板应用示意图）

雷达物位计提供了非线性输出映射功能。用户可根据液位与流量的对应关系，利用GODAware软件设置非线性输出映射，从而实现明渠流量的测量。

GODAware软件给出了规程中规定的堰槽的计算,用户设置了相应的参数后,可计算出相应的堰槽的非线性映射,并传送给雷达物位计保存。

明渠流量示意图

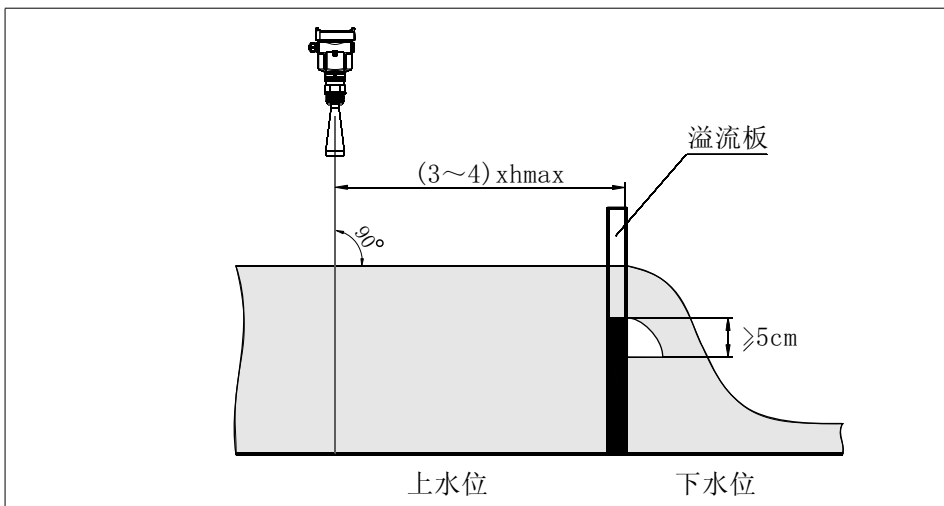
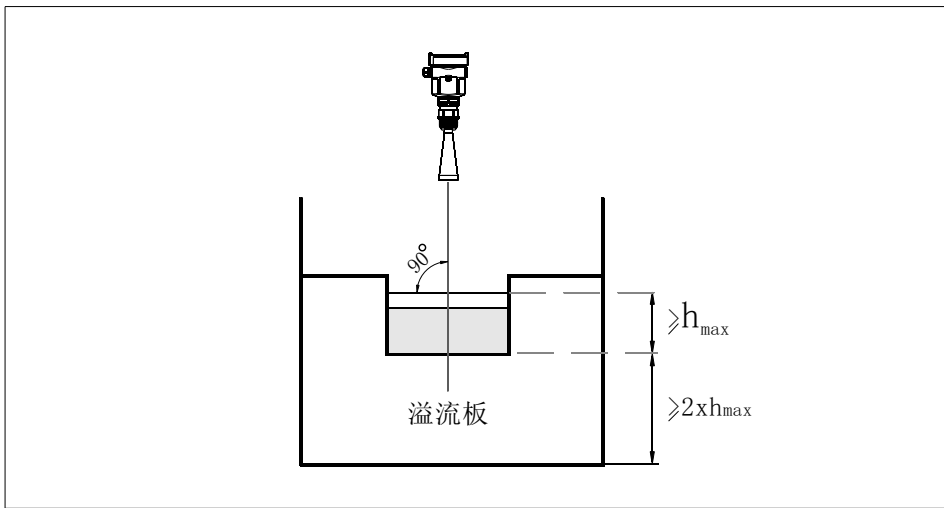

8 Selections & Ordering Information

● SDRD55

Explosive Proof Approval	
P	Standard (without Approval)
I	Intrinsically safe (Exia IIC T6)
C	Intrinsically safe + Flameproof Approval Exd ia IIC T6
Shape of Antenna/Material/Process Temperature	
B	(R)Airproof Horn 50/PTFE/(40~130)° C
C	(R) Airproof Horn 80/PTFE/(40~130)° C
Process Connection/Material	
GP	(F)Thread G1 ¹ / ₂ A
NP	(F) Thread1 ¹ / ₂ NPT
SP	(F) Thread G3A
TP	(F) Thread 3NPT
FA	(L)Flange DN50/PTFE
FB	(L)Flange DN80/PTFE
FX	Special design
Guided wave	
A	Without
X	Special design
Electronic	
B	(4-20)mA/Hart 2 wire (single chamber)
C	(4-20)mA/(22.8~26.4)VDC/Hart 4 wire (2-chamber)
D	(198~242)VAC/Hart four wire(2- chamber)
E	(4-20)mA/(22.8~26.4)VDC/Hart 2 wire (2-chamber)
X	Special design
Housing/Protection	
A	Aluminum/IP67
B	Plastic /IP66
C	PP (anti-static)/IP66
D	Aluminum(2-chamber)/IP67
G	Stainless steel 316L/ IP67
H	Stainless steel 316L(2-chamber)/ IP67
Cable Entry	
M	M20×1.5
N	1 ¹ / ₂ NPT
Display/Programming	
A	YES
X	NO

Note: Only "B" "electronics and "C"&"G" housing can be selected for intrinsically safe (Exia IIC T6)

Only "C,D,E" "electronics and "D,H" housing can be selected for Intrinsically safe + Flameproof Approval Exd ia IIC T6

Flange Dimensions: GB/T9119-2000 PN1.6Mpa, the thickness is 15mm.

Caution: None-metal parts has static, pay attention to discharge; avoiding friction and do not clean when it is dry; Do not install in flowing no-conductive environment.

● SDRD56

Explosive Proof Approval																										
P	Standard (without Approval)																									
I	Intrinsically safe (Exia IIC T6)																									
G	Intrinsically safe + Flameproof Approval Exd ia IIC T6																									
Shape of Antenna/Material/Process Temperature																										
B	(T) Horn Φ 48mm/Stainless steel 316L																									
C	(T) Horn Φ 78mm/ Stainless steel 316L																									
H	(T) Horn Φ 98mm/ Stainless steel 316L																									
I	(T) Horn Φ 98mm(Length)/ Stainless steel 316L																									
J	(T) Horn Φ 123mm/ Stainless steel 316L																									
M	(V) Horn Φ 98mm/ Stainless steel 316L/PFA430 shield																									
N	(V) Horn Φ 98mm(Length)/ Stainless steel 316L/PFA430 shield																									
P	V) Horn Φ 123mm/ Stainless steel 316L/PFA430 shield																									
X	Special design																									
Process Connection/Material																										
GP	(H)Thread G1 $\frac{1}{2}$ A/ Stainless steel 316L																									
GA	(H) Thread1 $\frac{1}{2}$ NPT/ Stainless steel 316L																									
GB	(G) Thread G1 $\frac{1}{2}$ A/PP																									
GC	(J) Thread G1 $\frac{1}{2}$ A/ Stainless steel 316L/(-60~250) $^{\circ}$ C																									
GD	(K) Thread G1 $\frac{1}{2}$ A/ Stainless steel 316L/(-60~400) $^{\circ}$ C,40Mpa																									
GE	(I) Thread G1 $\frac{1}{2}$ A/ Stainless steel 316L/Huff																									
GX	Special design																									
Flange/Material																										
	<table border="1"> <thead> <tr> <th>Material Spec. Code</th> <th>PP(L)</th> <th>PTFE(L)</th> <th>Stainless Steel(M)</th> <th>Gimbal Flange(PP) (N)</th> </tr> </thead> <tbody> <tr> <td>DN50</td> <td>FA</td> <td>FB</td> <td>FC</td> <td>-</td> </tr> <tr> <td>DN80</td> <td>GA</td> <td>GB</td> <td>GC</td> <td>-</td> </tr> <tr> <td>DN100</td> <td>HA</td> <td>HB</td> <td>HC</td> <td>HD</td> </tr> <tr> <td>DN125</td> <td>IA</td> <td>IB</td> <td>IC</td> <td>ID</td> </tr> </tbody> </table>	Material Spec. Code	PP(L)	PTFE(L)	Stainless Steel(M)	Gimbal Flange(PP) (N)	DN50	FA	FB	FC	-	DN80	GA	GB	GC	-	DN100	HA	HB	HC	HD	DN125	IA	IB	IC	ID
Material Spec. Code	PP(L)	PTFE(L)	Stainless Steel(M)	Gimbal Flange(PP) (N)																						
DN50	FA	FB	FC	-																						
DN80	GA	GB	GC	-																						
DN100	HA	HB	HC	HD																						
DN125	IA	IB	IC	ID																						
F0	Without																									
Fx	Special design																									
Seal/Process Temperature																										
2	Viton(-60~150) $^{\circ}$ C																									
3	Kalrez (-60~250) $^{\circ}$ C																									
4	Graphite (-60~400) $^{\circ}$ C																									
Electronic																										
B	(4-20)mA/Hart 2 wire (single chamber)																									
C	(4-20)mA/(22.8~26.4)VDC/Hart 4 wire (2-chamber)																									
D	(198~242)VAC/Hart four wire(2-chamber)																									
E	(4-20)mA/(22.8~26.4)VDC/Hart 2 wire (2-chamber)																									
X	Special design																									
Housing/Protection																										
A	Aluminum/IP67																									
B	Plastic /IP66																									
C	PP (anti-static)/IP66																									

								D	Aluminum(2-chamber)/IP67
								G	Stainless steel 316L/ IP67
								H	Stainless steel 316L(2-chamber)/ IP67
								Cable Entry	
								M	M20×1.5
								N	1/2 NPT
								Display/Programming	
								A	YES
								X	NO

Note: Only "B" "electronics and "C"&"G" housing can be selected for intrinsically safe (Exia IIC T6)

Only "C,D,E" "electronics and "D,H" housing can be selected for Intrinsically safe + Flameproof Approval Exd ia IIC T6

Flange Dimensions: GB/T9119-2000 PN1.6Mpa, the thickness is 15mm.

● SDRD 57

Explosive Proof Approval	
P	Standard (without Approval)
I	Intrinsically safe (Exia IIC T6)
G	Intrinsically safe + Flameproof Approval Exd ia IIC T6
Shape of Antenna/Material/Process Temperature	
B	(U)Stainless steel &PTFE Flange DN50
C	(U)Stainless steel &PTFE Flange DN80
D	(U)Stainless steel &PTFE Flange DN100
X	Special Design
Electronic	
B	(4-20)mA/Hart 2 wire (single chamber)
C	(4-20)mA/(22.8~26.4)VDC/Hart 4 wire (2-chamber)
D	(198~242)VAC/Hart four wire(2-chamber)
E	(4-20)mA/(22.8~26.4)VDC/Hart 2 wire (2-chamber)
X	Special design
Housing/Protection	
A	Aluminum/IP67
B	Plastic /IP66
C	PP (anti-static)/IP66
D	Aluminum(2-chamber)/IP67
G	Stainless steel 316L/ IP67
H	Stainless steel 316L(2-chamber)/ IP67
Cable Entry	
M	M20×1.5
N	1/2 NPT
Display/Programming	
A	YES
X	NO

Note: Only "B" "electronics and "C"&"G" housing can be selected for intrinsically safe (Exia IIC T6)

Only "C,D,E" "electronics and "D,H" housing can be selected for Intrinsically safe + Flameproof Approval Exd ia IIC T6

Flange Dimensions: GB/T9119-2000 PN1.6Mpa, the thickness is 15mm.

Caution: None-metal parts has static, pay attention to discharge; avoiding friction and do not clean when it is dry; Do not install in flowing no-conductive environment.

● SDRD58

Explosive Proof Approval																																									
P	Standard (without Approval)																																								
I	Intrinsically safe (Exia IIC T6)																																								
G	Intrinsically safe + Flameproof Approval Exd ia IIC T6																																								
Shape of Antenna/Material/Process Temperature																																									
B	(T) Horn Φ 48mm/Stainless steel 316L																																								
C	(T) Horn Φ 78mm/ Stainless steel 316L																																								
H	(T) Horn Φ 98mm/ Stainless steel 316L																																								
I	(T) Horn Φ 98mm(Length)/ Stainless steel 316L																																								
J	(T) Horn Φ 123mm/ Stainless steel 316L																																								
M	(V) Horn Φ 98mm/ Stainless steel 316L/PFA430 shield																																								
N	(V) Horn Φ 98mm(Length)/ Stainless steel 316L/PFA430 shield																																								
P	V) Horn Φ 123mm/ Stainless steel 316L/PFA430 shield																																								
Q	(W) Parabolic Antenna Φ 198mm/ Stainless steel 316L																																								
R	(W) Parabolic Antenna Φ 246mm/ Stainless steel 316L																																								
X	Special design																																								
Process Connection/Material																																									
GP	(H)Thread G1 ¹ / ₂ A/ Stainless steel 316L																																								
GA	(H) Thread1 ¹ / ₂ NPT/ Stainless steel 316L																																								
GB	(G) Thread G1 ¹ / ₂ A/PP																																								
GC	(J) Thread G1 ¹ / ₂ A/ Stainless steel 316L/(-60~250)° C																																								
GD	(K) Thread G1 ¹ / ₂ A/ Stainless steel 316L/(-60~400)° C,40Mpa																																								
GE	(I) Thread G1 ¹ / ₂ A/ Stainless steel 316L/Huff																																								
GF	(E) Thread G1 ¹ / ₂ A/ Stainless steel 316L/(-60~150)° C																																								
GX	Special design																																								
Flange/Material																																									
	<table border="1"> <thead> <tr> <th>Materi. Spec. Code</th> <th>PP(L)</th> <th>PTFE(L)</th> <th>Stainless steel(M)</th> <th>Gimbal Flange (Stainless steel)(P)</th> </tr> </thead> <tbody> <tr> <td>DN50</td> <td>FA</td> <td>FB</td> <td>FC</td> <td>--</td> </tr> <tr> <td>DN80</td> <td>GA</td> <td>GB</td> <td>GC</td> <td>--</td> </tr> <tr> <td>DN100</td> <td>HA</td> <td>HB</td> <td>HC</td> <td>HE</td> </tr> <tr> <td>DN125</td> <td>IA</td> <td>IB</td> <td>IC</td> <td>IE</td> </tr> <tr> <td>DN150</td> <td>JA</td> <td>JB</td> <td>JC</td> <td>JE</td> </tr> <tr> <td>DN200</td> <td>KA</td> <td>KB</td> <td>KC</td> <td>KE</td> </tr> <tr> <td>DN250</td> <td>LA</td> <td>LB</td> <td>LC</td> <td>LE</td> </tr> </tbody> </table>	Materi. Spec. Code	PP(L)	PTFE(L)	Stainless steel(M)	Gimbal Flange (Stainless steel)(P)	DN50	FA	FB	FC	--	DN80	GA	GB	GC	--	DN100	HA	HB	HC	HE	DN125	IA	IB	IC	IE	DN150	JA	JB	JC	JE	DN200	KA	KB	KC	KE	DN250	LA	LB	LC	LE
Materi. Spec. Code	PP(L)	PTFE(L)	Stainless steel(M)	Gimbal Flange (Stainless steel)(P)																																					
DN50	FA	FB	FC	--																																					
DN80	GA	GB	GC	--																																					
DN100	HA	HB	HC	HE																																					
DN125	IA	IB	IC	IE																																					
DN150	JA	JB	JC	JE																																					
DN200	KA	KB	KC	KE																																					
DN250	LA	LB	LC	LE																																					
F0	Without																																								
Fx	Special design																																								
Seal/Process Temperature																																									
2	Viton(-60~150)° C																																								
3	Kalrez (-60~250)° C																																								
4	Graphite (-60~400)° C																																								
Electronic																																									
B	(4-20)mA/Hart 2 wire (single chamber)																																								
C	(4-20)mA/(22.8~26.4)VDC/Hart 4 wire (2-chamber)																																								
D	(198~242)VAC/Hart four wire(2-chamber)																																								
E	(4-20)mA/(22.8~26.4)VDC/Hart 2 wire (2-chamber)																																								

						X	Special design
							Housing/Protection
						A	Aluminum/IP67
						B	Plastic /IP66
						C	PP (anti-static)/IP66
						D	Aluminum(2-chamber)/IP67
						G	Stainless steel 316L/ IP67
						H	Stainless steel 316L(2-chamber)/ IP67
							Cable Entry
						M	M20×1.5
						N	1/2 NPT
							Display/Programming
						A	YES
						X	NO

Note: Only "B" "electronics and "C"&"G" housing can be selected for intrinsically safe (Exia IIC T6)

Only "C,D,E" "electronics and "D,H" housing can be selected for Intrinsically safe + Flameproof Approval Exd ia IIC T6

Flange Dimensions: GB/T9119-2000 PN1.6Mpa, the thickness is 15mm.

● SDRD59

Explosive Proof Approval																																									
P	Standard (without Approval)																																								
I	Intrinsically safe (Exia IIC T6)																																								
G	Intrinsically safe + Flameproof Approval Exd ia IIC T6																																								
Shape of Antenna/Material/Process Temperature																																									
B	(T) Horn Φ 48mm/Stainless steel 316L																																								
C	(T) Horn Φ 78mm/ Stainless steel 316L																																								
H	(T) Horn Φ 98mm/ Stainless steel 316L																																								
I	(T) Horn Φ 98mm(Length)/ Stainless steel 316L																																								
J	(T) Horn Φ 123mm/ Stainless steel 316L																																								
M	(V) Horn Φ 98mm/ Stainless steel 316L/PFA430 shield																																								
N	(V) Horn Φ 98mm(Length)/ Stainless steel 316L/PFA430 shield																																								
P	V) Horn Φ 123mm/ Stainless steel 316L/PFA430 shield																																								
Q	(W) Parabolic Antenna Φ 198mm/ Stainless steel 316L																																								
R	(W) Parabolic Antenna Φ 246mm/ Stainless steel 316L																																								
X	Special design																																								
Process Connection/Material																																									
GP	(H)Thread G1 ¹ / ₂ A/ Stainless steel 316L																																								
GA	(H) Thread1 ¹ / ₂ NPT/ Stainless steel 316L																																								
GB	(G) Thread G1 ¹ / ₂ A/PP																																								
GE	(I) Thread G1 ¹ / ₂ A/ Stainless steel 316L/Huff																																								
GF	(E) Thread G1 ¹ / ₂ A/ Stainless steel 316L/(-60~150)° C																																								
GX	Special design																																								
Flange/Material																																									
	<table border="1"> <thead> <tr> <th>Spec. Code</th> <th>Materi. PP(L)</th> <th>PTFE(L)</th> <th>Stainless steel(M)</th> <th>Gimbal Flange (Stainless steel)(P)</th> </tr> </thead> <tbody> <tr> <td>DN50</td> <td>FA</td> <td>FB</td> <td>FC</td> <td>--</td> </tr> <tr> <td>DN80</td> <td>GA</td> <td>GB</td> <td>GC</td> <td>--</td> </tr> <tr> <td>DN100</td> <td>HA</td> <td>HB</td> <td>HC</td> <td>HE</td> </tr> <tr> <td>DN125</td> <td>IA</td> <td>IB</td> <td>IC</td> <td>IE</td> </tr> <tr> <td>DN150</td> <td>JA</td> <td>JB</td> <td>JC</td> <td>JE</td> </tr> <tr> <td>DN200</td> <td>KA</td> <td>KB</td> <td>KC</td> <td>KE</td> </tr> <tr> <td>DN250</td> <td>LA</td> <td>LB</td> <td>LC</td> <td>LE</td> </tr> </tbody> </table>	Spec. Code	Materi. PP(L)	PTFE(L)	Stainless steel(M)	Gimbal Flange (Stainless steel)(P)	DN50	FA	FB	FC	--	DN80	GA	GB	GC	--	DN100	HA	HB	HC	HE	DN125	IA	IB	IC	IE	DN150	JA	JB	JC	JE	DN200	KA	KB	KC	KE	DN250	LA	LB	LC	LE
Spec. Code	Materi. PP(L)	PTFE(L)	Stainless steel(M)	Gimbal Flange (Stainless steel)(P)																																					
DN50	FA	FB	FC	--																																					
DN80	GA	GB	GC	--																																					
DN100	HA	HB	HC	HE																																					
DN125	IA	IB	IC	IE																																					
DN150	JA	JB	JC	JE																																					
DN200	KA	KB	KC	KE																																					
DN250	LA	LB	LC	LE																																					
F0	Without																																								
Fx	Special design																																								
Seal/Process Temperature																																									
2	Viton(-60~150)° C																																								
3	Kalrez (-60~250)° C																																								
4	Graphite (-60~400)° C																																								
Electronic																																									
B	(4-20)mA/Hart 2 wire (single chamber)																																								
C	(4-20)mA/(22.8~26.4)VDC/Hart 4 wire (2-chamber)																																								
D	(198~242)VAC/Hart four wire(2-chamber)																																								
E	(4-20)mA/(22.8~26.4)VDC/Hart 2 wire (2-chamber)																																								
X	Special design																																								
Housing/Protection																																									

9 Application Questionnaire

Approvals

- Standard Version Intrinsically Safe Version (Exia IIC T6) Intrinsically Safe Version (Exia IIC T6)
 Intrinsically Safe Version+Ship Approval (Exia IIC T6) Intrinsically Safe Version+Explosion Proof (Exd [ia] IIC T6)

Measured Medium

Name _____

Condition Liquid (Solid (Form Mass Particle Dust)

Temperature: Min. _____ °C Norm. _____ °C Max. _____ °C

Surface Flat Turbulent Agitated Vortex

Dielectric Constant $\epsilon_r < 3$ $\epsilon_r > 3$

Atmosphere

Atmosphere Form Foam Dust Deposit Vapour

Atmosphere Pressure Min. _____ Norm. _____ Max. _____

Vessel

Shape of Top Flat Arch Conical Horizontal

Height _____ Diameter _____

Critical Information

Nozzle Length: _____ Nozzle Diameter: _____ Measurement Range: _____

Process Connection

Thread (G $\frac{3}{4}$ A $\frac{3}{4}$ NPT G1A G1A, M105x2 G1 $\frac{1}{2}$ A 1 $\frac{1}{2}$ NPT G2A)

Flange (DN=) Swivelling Holder

Installation

Mode: Top Side

Filling Stream inlet position and installation position (Please specify in the diagram below)

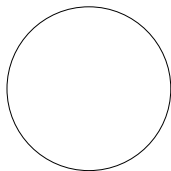

Circular Vessel



Square Vessel

Power Supply

220V AC 2-wire 24V DC 3-wire 24V DC 4-wire 24V DC

Communication

(4~20) mA/HART

Display

Yes No

Customer Information

Contact: _____

Company: _____

Address: _____

P. C.: _____ Tel: _____

Email: _____ Fax: _____

Please give brief explanation on the application of instrument:

Date: _____