

SAFETY SWITCH HEAD CONNECTION

PRODUCT DESCRIPTION

Mechan Safety Switch heads are a special type of proximity switch, differing from standard types in two important areas:- a) They are fail safe; b) They can only be actuated by a Mechan target block.

Mechan Safety Switch heads generate a Dynamic Analogue Output Signal which is inherently fail safe insofar as component failure, or damage to interconnecting cables, is concerned. Both "F" and "B" series heads are completely solid-state electronic devices, resin encapsulated into ABS shells, providing extremely high reliability and total sealing to IP67. They are tough, easy to fit, and contain no magnets, moving parts or contacts to stick or wear out.

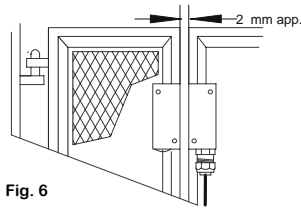

Fig. 6

HEAD FIXING

The heads can be mounted on hinged, sliding or removable guards. Ensure the targets are aligned and there is approximately 2-3 mm between the sensitive faces when the guards are closed. This gives maximum lateral tolerance and freedom from nuisance tripping due to guard vibration. **Do not enlarge the fixing holes.**

CABLE

Run the head cable back to the control unit, and connect into the terminal block as shown.

Treat the head cables as instrument cables and keep separate from power cables, 150mm is usually sufficient.

The head cable may be extended if required using a similar type of cable (Belden Type 8761) and runs of up to 100 metres will not significantly affect performance. Multi way versions of Individually screened and twisted pair cables are available for running several heads back to a control unit. Cable joints should be moisture proof and not earthed. The only earth connection should be via the green terminal at the control unit input block.

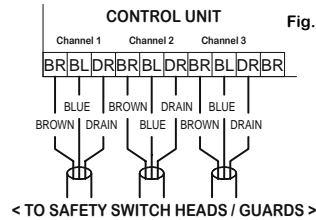

Fig. 7

FOR MORE INFORMATION SEE OUR 'INSTALLATION GUIDE FOR SAFETY SWITCH HEADS'

MPX4/DIN CONTROL UNIT SPECIFICATION

SWITCH CHANNEL SELECTION	1 to 4 CHANNEL OPERATION
SUPPLY VOLTAGES AVAILABLE	24, 48, 110, 240vAC / 24vDC
POWER CONSUMPTION	6VA
MAXIMUM SWITCHING CAPACITY	2A, 240vAC / 2A 30vDC RES.
PROTECTION	HOUSING - IP40 TERMINALS - IP20
DIMENSIONS	100 x 75 x 110 mm
MOUNTING	35MM DIN RAIL / 2 X 4 mm HOLES
OPERATING TEMP. STORAGE TEMP.	0 TO 45C -20 TO +50C
SYSTEM INDICATION	POWER ON LED GUARDS CLOSED LED FAULT LED
CHANNEL INDICATION	4 X VOLT FREE CONTACT. (125V 0.5A RES.) 4 X LED's

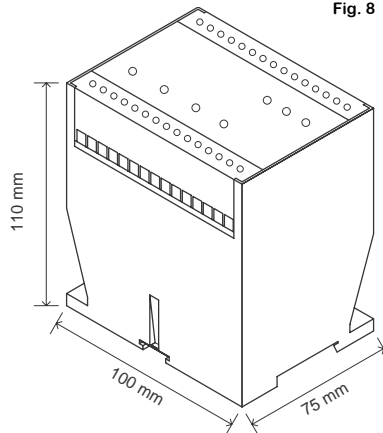
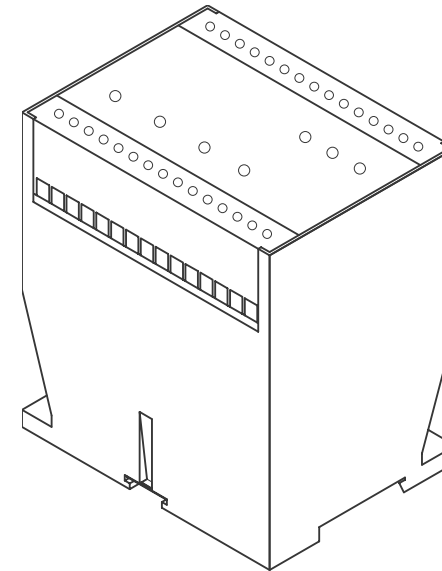

Fig. 8



INSTALLATION GUIDELINES MPX4/DIN

**FOR
SAFETY
AND
RELIABILITY**



MECHAN CONTROLS LIMITED
14/16 Seddon Place
Stanley Industrial Estate
Skelmersdale
Lancashire WN8 8EB
England
Telephone (44) 01695 722264

MPX4/DIN CONTROL UNIT STANDARD INSTALLATION CONFIGURATION

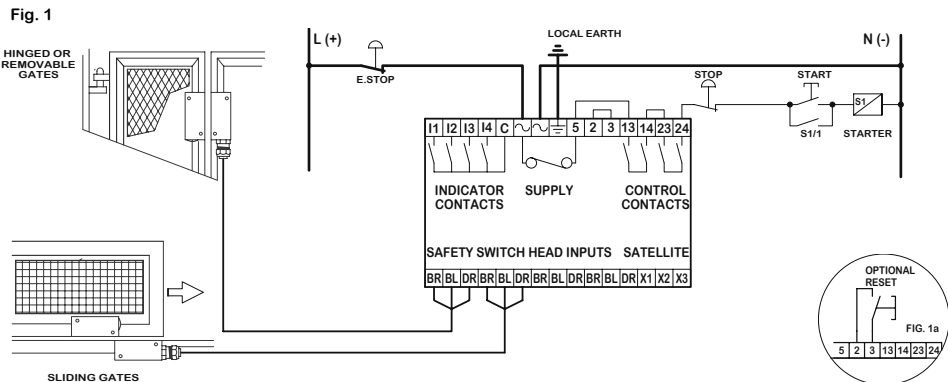

PRODUCT DESCRIPTION

The Mechan MPX4/DIN Control Unit takes signals from the unique Mechan Safety Switch heads and processes them using 'Dynamic Fail Safe Amplifiers'. The **Dual Output Relays** are driven directly by this dynamic signal resulting in a system which is inherently proof against total semiconductor failure. Each of the output relays has two contacts in series with the load. The **Proving Relay** is also powered from the Mechan signal and provides monitoring of the output relays every time they operate. In the event of a faulty (welded) contact, or even a total relay failure, *full system safety is maintained* and a re-start is prevented. The "FAULT" LED indicates relay failure.

CONTROL CONTACTS

The Control Contacts are brought out to terminals, 13,14; and 23,24 and can be used with the fused (2A Max) live supply from terminal 5 (see fig 1), or as volt free contacts by removing the link between terminals 5 and 13. These contacts should be used in series as shown in fig. 1 for standard risk applications. These contacts are monitored every time a guard is closed or an emergency stop button is reset.

INDICATOR CONTACTS

When a guard is opened the indicator contact for that channel closes. These contacts are for *indication purposes only*.

SAFETY SWITCH HEAD CONNECTION

See back page for installation information.

CHANNEL SELECTION

Set the MPX4/DIN to the required number of channels, see fig 2a for the correct switch settings.



WARNING

Disconnect from supply before removing lid.

Lift lid off with a screwdriver in the terminal recess to access the channel selection switch.

Fig. 2

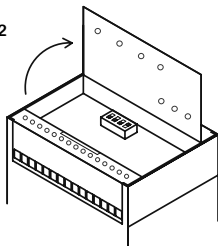

ACTIVE CHANNELS REQUIRED	SWITCH SETTING
1	1
1 THROUGH 2	1 2
1 THROUGH 3	1 2 3
1 THROUGH 4	1 2 3 4
SATELLITE	1 2 3 4

IMPORTANT THE ABOVE SWITCH SETTINGS SHOULD BE STRICTLY ADHERED TO.

Fig. 2a

NOTES - The earth connection should be "clean" and local to the control unit. The on board arc suppression devices are only effective when the recommended circuits are used. Other configurations may require external suppression devices.

MULTIPLE STANDARD SYSTEMS

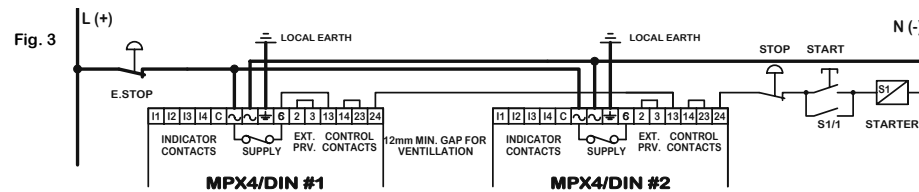

MPX control units can be linked in series to make up the number of channels required. When using multiple systems and the fused live supply from terminal 5, only one link, on the first control unit, is required between terminal 5 and terminal 13.

DUAL AND CROSS MONITORED SYSTEMS

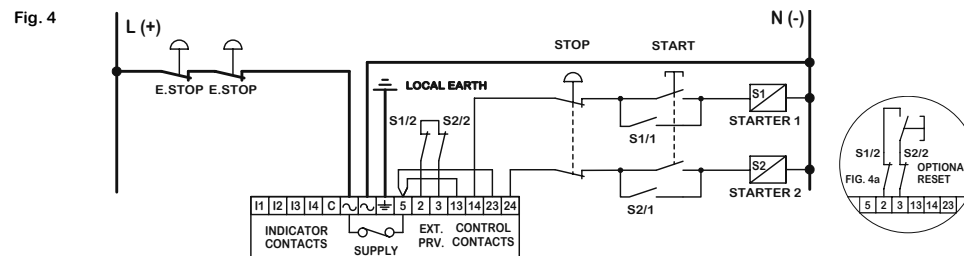

EXTERNAL PROVING CIRCUIT

A normally closed contact on each starter / contactor should be linked in series with the Mechan proving circuit. (terminal 2 & 3 in figure 4) In the event of a starter / contactor welding, the next time the Mechan system is operated or an emergency stop button is pressed, the system will stop and a re-start is prevented by the Mechan proving circuit. The 'FAULT LED' will light on the control unit.

MULTIPLE DUAL SYSTEMS

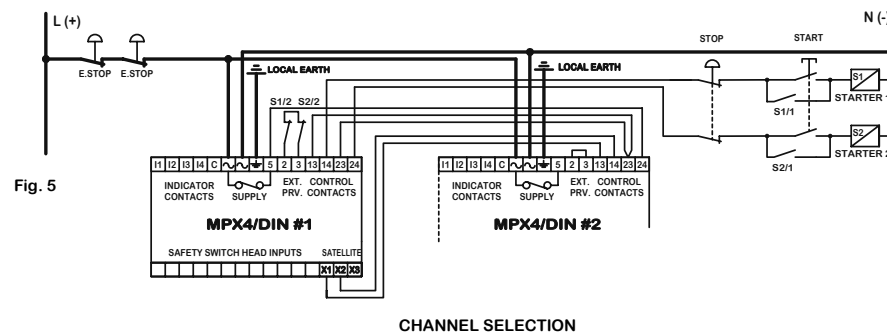

CHANNEL SELECTION

IMPORTANT - Mechan safety equipment should be installed by qualified personnel. All system functions should be tested after installation to ensure correct operation.