

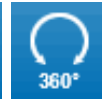

Solid mechanical construction  
 Protection to IP 65, IP 66  
 SMD technology  
 Electronic preset  
 Connection to fieldbus over suitable gateway



## Absolut Encoder EA 58 / EAS 58 Parallel

Optical absolute shaft encoders of high resolution

### Resolution

#### Resolution (Steps/360°):

65536 = 16 Bits

8192 = 13 Bits

4096 = 12 Bits

### Type explanation

#### EA 58-8192G-30-P-SC16

Encoder type	Absolute
Flange type	Servo- / Klemmflansch
Flange diameter	ø 58 mm
Case diameter	ø 58 mm
Number of bits	65536 = 16 Bits 8192 = 13 Bits 4096 = 12 Bits
Single-turn	Yes
Electronic adjustment	Yes
Supply voltage	30 = 10 .. 30 VDC
Output driver	P
Position of connection	R S
Connector	C16 = 16 pins M23 C26 = 26 pins M27
Shaft diameter	ø 10 mm

## Technical data

### Mechanical data

Rotational speed	? 12.000 min <sup>-1</sup>
Torque	? 3 Ncm
Moment of inertia	30 g cm <sup>2</sup>
Loading of bearings	110 N radial 40 N axial
Operational life of ball bearings	> 2 x 10 <sup>5</sup> h (1000 min <sup>-1</sup> , EAS 58) > 1 x 10 <sup>5</sup> h (1000 min <sup>-1</sup> , EA 58)
Weight	? 0,25 kg

### Environmental conditions

Vibration	100 m/s <sup>2</sup> (10 ... 1000 Hz)
Shock	300 m/s <sup>2</sup> (11 ms)
Storage temperature	40 ... +85°C
Atmospheric humidity	? 98% r.h.
Protection class	IP 65 (DIN 40050/IEC 144) IP 66 (optional)

### Electrical data

Scanning type	Optical, without contact
Transmitter, infrared	LED
Receiver	Photo-Array
Output frequency LSB	800 kHz
Measurement accuracy	± ½ LSB (12 bit) ± 1 LSB (13 bit) ± 2 LSB (16 bit)
Supply voltage	V <sub>cc</sub> = 10 .. 30 VDC
Power consumption	? 100 mA (V <sub>cc</sub> = 24 V)
Output frequency	? 100 kHz
Load capacity of the outputs	20 mA

### Electrical connections

#### Inputs

Date	Bit 0 ... Bit n
Rotational direction	CW/CCW
Electronic adjustment	RESET (optional)
Store (Binary code)	STORE

### Connector 16 pins M23

Connection	Signal
Pin 1	G 0 / 2 <sup>0</sup>
Pin 2	G 1 / 2 <sup>1</sup>
Pin 3	G 2 / 2 <sup>2</sup>
Pin 4	G 3 / 2 <sup>3</sup>
Pin 5	G 4 / 2 <sup>4</sup>
Pin 6	G 5 / 2 <sup>5</sup>
Pin 7	G 6 / 2 <sup>6</sup>
Pin 8	G 7 / 2 <sup>7</sup>
Pin 9	G 8 / 2 <sup>8</sup>
Pin 10	G 9 / 2 <sup>9</sup>
Pin 11	G 10 / 2 <sup>10</sup>
Pin 12	G 11 / 2 <sup>11</sup>
Pin 13	CW/CCW
Pin 14	G 12 / 2 <sup>12</sup> oder STORE <sup>1)</sup>
Pin 15	+Vcc
Pin 16	0 V GND

1) G12/2<sup>12</sup> bei 13 Bit, STORE bei Binär-Code, sonst N.C.

### Connector 26 pins M27

Connection	Signal
Pin 1	G 0 / 2 <sup>0</sup>
Pin 2	G 1 / 2 <sup>1</sup>
Pin 3	G 2 / 2 <sup>2</sup>
Pin 4	G 3 / 2 <sup>30</sup>
Pin 5	G 4 / 2 <sup>4</sup>
Pin 6	G 5 / 2 <sup>5</sup>
Pin 7	G 6 / 2 <sup>6</sup>
Pin 8	G 7 / 2 <sup>7</sup>
Pin 9	G 8 / 2 <sup>8</sup>
Pin 10	G 9 / 2 <sup>9</sup>
Pin 11	G 10 / 2 <sup>10</sup>
Pin 12	G 11 / 2 <sup>11</sup>
Pin 13	G 12 / 2 <sup>12</sup>
Pin 14	G 13 / 2 <sup>13</sup>
Pin 15	G 14 / 2 <sup>14</sup>
Pin 16	G 15 / 2 <sup>15</sup>
Pin 17	N.C.
Pin 18	N.C.
Pin 19	N.C.
Pin 20	N.C.
Pin 21	N.C.
Pin 22	Reset <sup>1)</sup>
Pin 23	Store <sup>2)</sup>
Pin 24	CW/CCW
Pin 25	+Vcc
Pin 26	0 V GND

1) optional

2) nur bei Binär-Code

### Cable 12 bit

Wire colour	Signal
White	G 0 / 2 <sup>0</sup>
Brown	G 1 / 2 <sup>1</sup>
Green	G 2 / 2 <sup>2</sup>
Yellow	G 3 / 2 <sup>3</sup>
Grey	G 4 / 2 <sup>4</sup>
Pink	G 5 / 2 <sup>5</sup>
Blue	G 6 / 2 <sup>6</sup>
Red	G 7 / 2 <sup>7</sup>
Black	G 8 / 2 <sup>8</sup>
Violet	G 9 / 2 <sup>9</sup>
Grey/Pink	G 10 / 2 <sup>10</sup>
Red/Blue	G 11 / 2 <sup>11</sup>
Pink/Brown	Reset <sup>1)</sup>
White/Blue	CW/CCW
Brown/Blue	Store <sup>2)</sup>
White/Red	+Vcc
Brown/Red	0 V GND

1) optional

2) nur bei Binär

### Cable 13 bit

Wire colour	Signal
White	G 0 / 2 <sup>0</sup>
Brown	G 1 / 2 <sup>1</sup>
Green	G 2 / 2 <sup>2</sup>
Yellow	G 3 / 2 <sup>3</sup>
Grey	G 4 / 2 <sup>4</sup>
Pink	G 5 / 2 <sup>5</sup>
Blue	G 6 / 2 <sup>6</sup>
Red	G 7 / 2 <sup>7</sup>
Black	G 8 / 2 <sup>8</sup>
Violet	G 9 / 2 <sup>9</sup>
Grey/Pink	G 10 / 2 <sup>10</sup>
Red/Blue	G 11 / 2 <sup>11</sup>
White/Green	G 12 / 2 <sup>12</sup>
Pink/Brown	Reset <sup>1)</sup>
White/Blue	CW/CCW
Brown/Blue	Store <sup>2)</sup>
White/Red	+Vcc
Brown/Red	0 V GND

1) optional

2) nur bei Binär

## Cable 16 bit

Wire colour	Signal
White	G 0 / 2 <sup>0</sup>
Brown	G 1 / 2 <sup>1</sup>
Green	G 2 / 2 <sup>2</sup>
Yellow	G 3 / 2 <sup>3</sup>
Grey	G 4 / 2 <sup>4</sup>
Pink	G 5 / 2 <sup>5</sup>
Blue	G 6 / 2 <sup>6</sup>
Red	G 7 / 2 <sup>7</sup>
Black	G 8 / 2 <sup>8</sup>
Violet	G 9 / 2 <sup>9</sup>
Grey/Pink	G 10 / 2 <sup>10</sup>
Red/Blue	G 11 / 2 <sup>11</sup>
White/Green	G 12 / 2 <sup>12</sup>
White/Yellow	G 13 / 2 <sup>13</sup>
Brown/Green	G 14 / 2 <sup>14</sup>
Yellow/Brown	G 15 / 2 <sup>15</sup>
Pink/Brown	Reset <sup>1)</sup>
White/Blue	CW/CCW
Brown/Blue	Store <sup>2)</sup>
White/Red	+Vcc
Brown/Red	0 V GND

1) optional

2) nur bei Binär

## Output driver

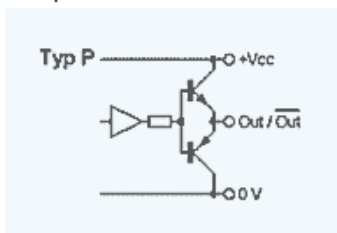

## Outline drawing

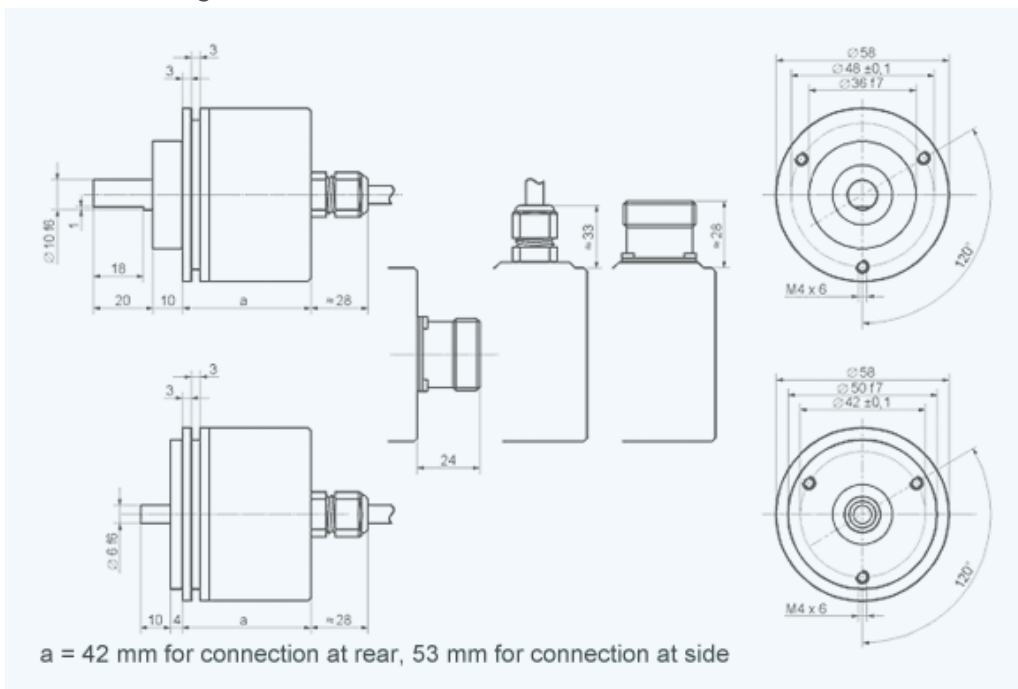

INDUcoder® · INDUcoder Messtechnik GmbH, Kaiserstraße 316, 47178 Duisburg, Deutschland  
Tel: (0203) 57047-0, Fax: (0203) 57047-20, E-Mail: [info@inducoder.de](mailto:info@inducoder.de), Internet:  
[www.inducoder.de](http://www.inducoder.de)