



Solid mechanical construction
 Protection to IP 65, IP 66
 SMD technology
 Electronic preset
 Connection to fieldbus over suitable gateway



Absolut Encoder EAM 57 / EAMS 57 SSI

Optical absolute multiturn shaft encoders of high resolution

Resolution

Resolution (Steps/360°):

4096 = 12 bit 8192 = 13 bit 65536 = 16 bit

Measuring range

Measuring range

Multi-Turn 4096 = 12 bit
 16384 turns = 14 bit

Type explanation

EAM 57-30G-30-D-SC12

Encoder type	Absolute
Flange type	Servo- / Klemmflansch
Flange diameter	ø 58 mm
Case diameter	ø 58 mm
Number of bits	24 = 12 bits x 4096 turns 25 = 13 bits x 4096 turns 28 = 16 bits x 4096 turns 26 = 12 bits x 16384 turns 27 = 13 bits x 16384 turns 30 = 16 bits x 16384 turns
Multi-turn	Yes
Electronic adjustment	Yes
Supply voltage	30 = 10..30 VDC
Output driver	D-SSI
Position of connection	DI R S
Connector	C12 = 12 pins M23
Shaft diameter	ø 10 mm

Technical data

Mechanical data

Rotational speed	? 6000 min ⁻¹
Torque	? 3 Ncm
Moment of inertia	30 g cm ²
Loading of bearings	110 N radial 40 N axial
Operational life of ball bearings	> 2 x 10 ⁵ h (1000 min ⁻¹ , EAMS 57) > 1 x 10 ⁵ h (1000 min ⁻¹ , EAM 57)
Weight	? 0,35 kg

Environmental conditions

Vibration	100 m/s ² (10 ... 1000 Hz)
Shock	300 m/s ² (11 ms)
Operating temperature	-40 ... +85°C
Storage temperature	-40 ... +85°C
Atmospheric humidity	? 98% r.h.
Protection class	DIN 40050/IEC 144 optional

Electrical data

Scanning type	Optical, without contact
Transmitter, infrared	LED
Receiver	Photo-Array
Scanning frequency LSB	800 kHz
Measurement accuracy	± ½ LSB (12 bit) ± 1 LSB (13 bit) ± 2 LSB (16 bit)
Supply voltage	V _{cc} = 10 .. 30 VDC
Power consumption	? 90 mA (V _{cc} = 24 V)

Electrical connections

SSI

Interface	RS485
Clock	Optocoupler

Incremental outputs

1024 pulses per revolution	AA+BB/90° RS422 (optional)
----------------------------	----------------------------

Inputs

Rotational direction	CW/CCW
Electronic adjustment	RESET (optional)

Connector 12 pins M23

Connection	Signal
Pin 1	+Vcc
Pin 2	0 V GND
Pin 3	Clock+
Pin 4	Data+
Pin 5	RESET ¹⁾
Pin 6	Data-
Pin 7	Clock-
Pin 8	A+ ²⁾
Pin 9	CW/CCW
Pin 10	B+ ²⁾
Pin 11	B- ²⁾
Pin 12	A- ²⁾

1) optional

2) nur bei Ausgangstreiber "DI"

Cable

Wire colour	Signal
White	0 V GND
Brown	+Vcc
Green	Clock+
Yellow	Clock-
Grey	Data+
Pink	Data-
Red	CW/CCW
Black	RESET ¹⁾

1) optional

Channel schematic

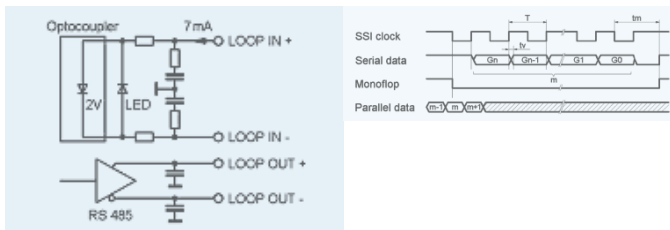

Outline drawing

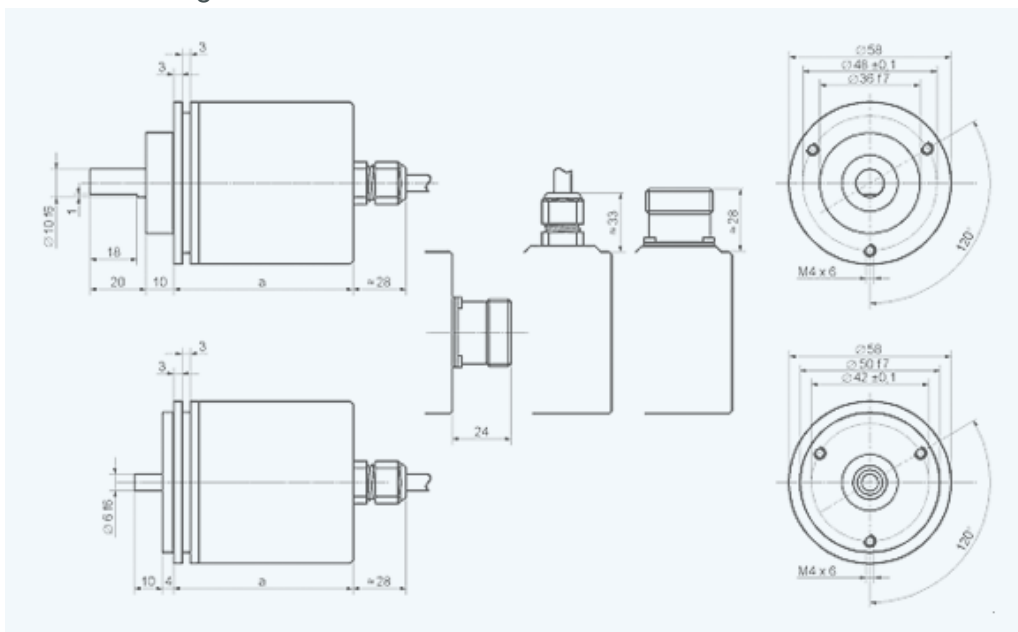

Version AE 565-311 · Subject to change

INDUcoder® · INDUcoder Messtechnik GmbH, Kaiserstraße 316, 47178 Duisburg, Deutschland
Tel: (0203) 57047-0, Fax: (0203) 57047-20, E-Mail: info@inducoder.de, Internet:
www.inducoder.de