

Solid mechanical construction  
 Protection to IP 65, IP 66  
 SMD technology  
 Electronic preset  
 Programmable



## Absolut No Shaft Encoder CAH 58 Profibus / CANopen<sup>®</sup> / Device Net

Optical absolute encoder with hollow shaft, Single-turn and multi-turn of high resolution

### Resolution

#### Resolution (Steps/360°):

4096 = 12 bit

8192 = 13 bit

65536 = 16 bit

### Measuring range

#### Measuring range

Single-Turn

1 turn

Multi-Turn

4096 Umdrehungen = 12 bit

16384 Umdrehungen = 14 bit

### Type explanation

#### CAH 58-28B-30-PB/Ø15

Encoder type	Absolute
Hollow shaft	Yes
Case diameter	ø 58 mm
Number of bits	12 = 12 bits x 1 turn 13 = 13 bits x 1 turn 16 = 16 bits x 1 turn 24 = 12 bits x 4096 turns 25 = 13 bits x 4096 turns 28 = 16 bits x 4096 turns 26 = 12 bits x 16384 turns 27 = 13 bits x 16384 turns 30 = 16 bits x 16384 turns
Single-turn	Yes
Multi-turn	Yes
Electronic adjustment	Yes
Supply voltage	30 = 10..30 VDC
Interface	PB = Profibus CO = CANopen <sup>®</sup> DN = Device Net
Shaft diameter	ø 15 mm

## Technical data

### Mechanical data

Rotational speed	? 12000 min <sup>-1</sup> (Single-turn) ? 6000 min <sup>-1</sup> (Multi-turn)
Torque	? 3 Ncm
Moment of inertia	30 g cm <sup>2</sup>
Loading of bearings	110 N radial 40 N axial
Operational life of ball bearings	> 1 x 10 <sup>5</sup> h (1000 min <sup>-1</sup> )
Weight	? 0,7 kg

### Environmental conditions

Vibration	100 m/s <sup>2</sup> (10 ... 1000 Hz)
Shock	300 m/s <sup>2</sup> (11 ms)
Operating temperature	-40 ... +85°C
Storage temperature	-40 ... +85°C
Atmospheric humidity	? 98% r.h.
Protection class	IP 65 (DIN 40050/IEC 144) IP 66 (optional)

### Electrical data

Scanning type	Optical, without contact
Transmitter, infrared	LED
Receiver	Photo-Array
Scanning frequency LSB	800 kHz
Measurement accuracy	±½ LSB (12 bit) ± 1 LSB (13 bit) ± 2 LSB (16 bit)
Supply voltage	V <sub>cc</sub> = 10...30 VDC
Power consumption	? 100 mA (V <sub>cc</sub> = 24 V)

### Electrical connections

#### Profibus

Interface	RS485 with optocoupler
Clock	max. 12 MBaud

## Outline drawing

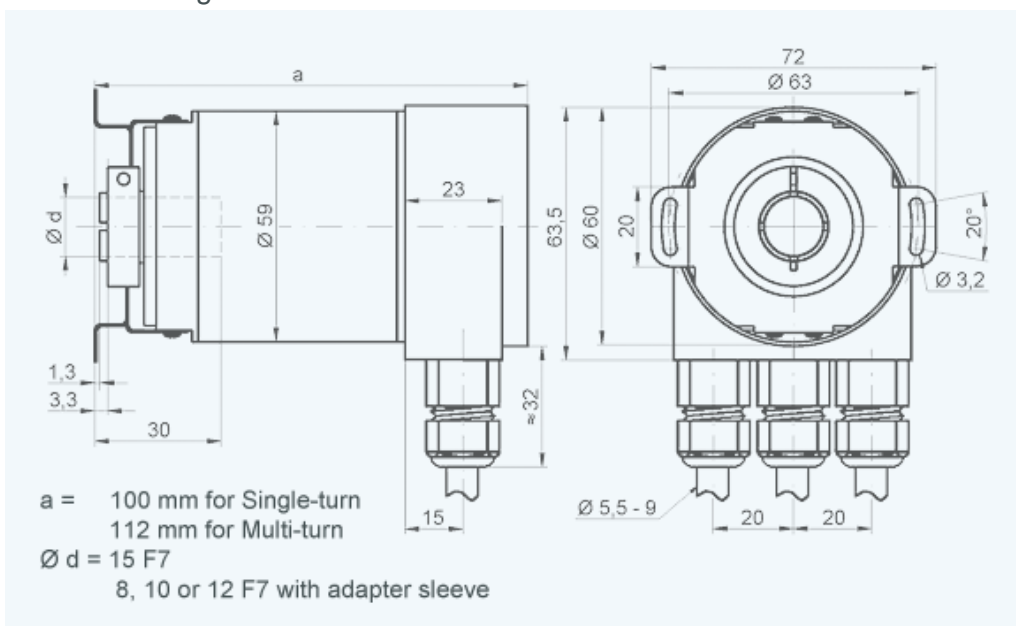

Version AE 670-411 · Subject to change

INDUcoder® · INDUcoder Messtechnik GmbH, Kaiserstraße 316, 47178 Duisburg, Deutschland  
Tel: (0203) 57047-0, Fax: (0203) 57047-20, E-Mail: [info@inducoder.de](mailto:info@inducoder.de), Internet:  
[www.inducoder.de](http://www.inducoder.de)