

**Moving the industry forward with  
the world's most reliable bogie systems.**

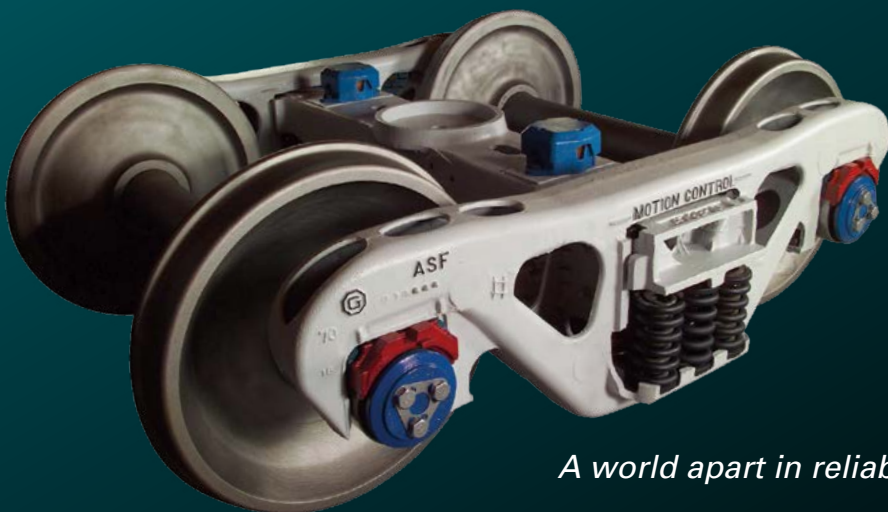

*A world apart in reliability*

**Amsted Rail®**



## **Amsted Rail's complete bogie assemblies – built for the long haul in heavy haul.**

Amsted Rail is the driving force in building the most reliable bogie car assemblies in the world. Through our ASF-Keystone Division, Amsted Rail designs and manufactures a range of complete bogie systems to satisfy every application, thrive in every environment and meet every challenge. All backed by our century-old AAR record for proven reliability.

### **Strength, safety and durability in one lightweight package.**

Utilizing our patented lightweight process, ASF-Keystone has been producing durable heavy haul lightweight bogie systems for customers from Brazil to Burma. By combining higher-yield B+ steel with a proprietary coring process, we're able to reduce weight by as much as 800 pounds per carset on average – without sacrificing strength.

Around the globe, ASF-Keystone® bogies consistently exceed the million-mile barrier, even in the ever-changing harsh operating climate of heavy haul freight transportation.

### **Fully customizable assemblies.**

Amsted Rail also has the capability to build custom bogie assemblies. Our team of engineers will work with you to customize a bogie assembly specifically suited to your needs.



## Advanced Bogies

### Motion Control®

*Delivering increased payloads and increased service time*

Amsted Rail pioneered the Motion Control design in 2003, and developed the first Motion Control system to get certification for North American AAR Interchange Service.

To stay at the forefront, every Motion Control bogie is engineered, designed and tested with Amsted Rail® core components. This ensures product interaction, providing optimal stability in the harshest operating environments while maximizing the wear life of components.

#### Key Benefits:

- Most versatile variable damped bogie for all asset types
- Lightest and most commonly specified M-976 bogie system available
- Lowest lifecycle maintenance costs
  - Adapter Plus® steering pad provides improved wheel and bearing service life
  - Longer friction wedge life
- First bogie to achieve unconditional AAR M-976 approval
- Optimal for 286,000 pound Gross Rail Load/32.5 tonne Axle Load

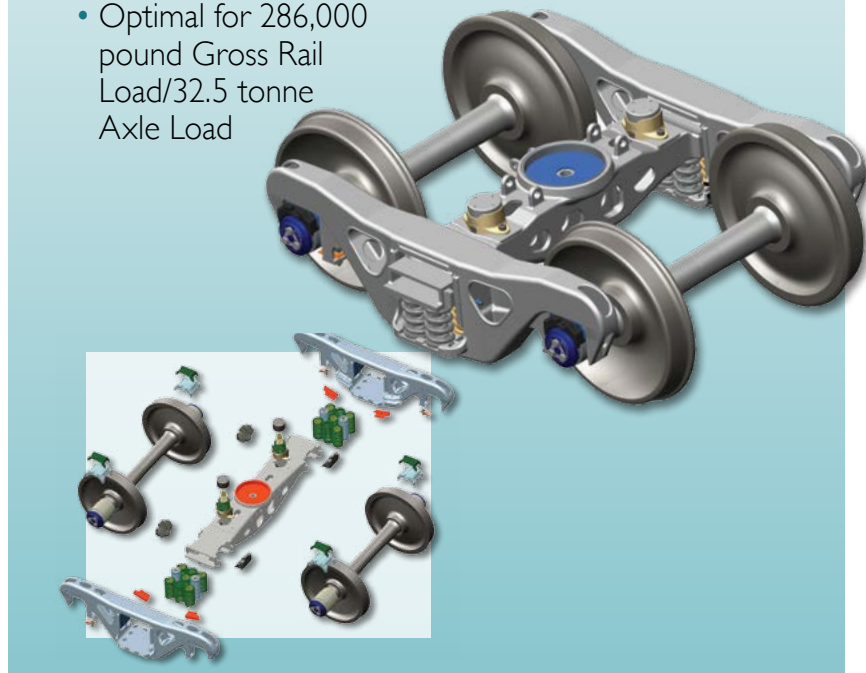

## Super Service Ride Control®

*Reduces wear and keeps the bogie square*

Designed for high utilization assets like coal cars, Super Service Ride Control® is a real workhorse. It combines proven wheel wear improvements and exceptional lifecycle costs.

First introduced back in the 1990's, it continues today to be one of our most widely popular design options.

### Key Benefits:

- Constant damped bogie
- Wide-winged friction wedge
  - Provides good stability
  - Keeps bogie square as components wear
- Up to 286,000 pound Gross Rail Load/  
32.5 tonne Axle Load

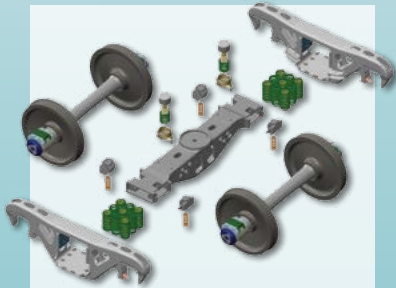
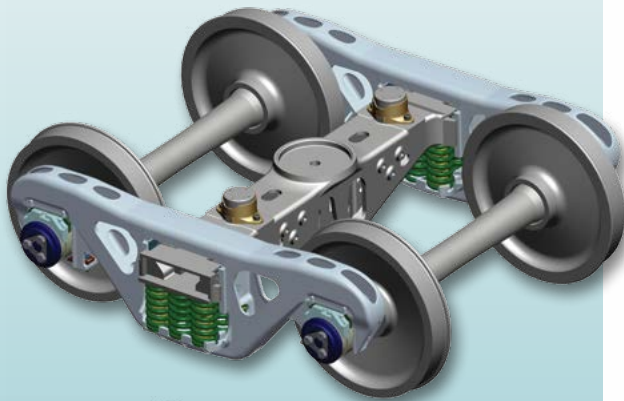

## Amsted HD Split Wedge

*Economical choice for mid to low utilized assets*

Introduced nearly 40 years ago, the Amsted HD Split Wedge truck design still remains an option for warm-climate customers around the globe as a standard variable damped, 3-piece bogie design. The Amsted HD Split Wedge is also available in a 125 ton configuration.

### Key Benefits:

- Variable damped bogie
- Equipped with split wedge damping
  - Provides adequate stability
  - Keeps bogie square
- Adapter Plus® steering pad provides improved wheel and bearing life
- Features Amsted Rail's proprietary casting process for less weight and increased tolerances
- Up to 286,000 pound Gross Rail Load/  
32.5 tonne Axle Load

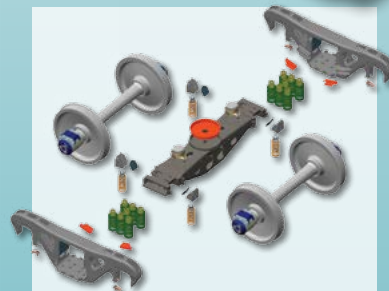
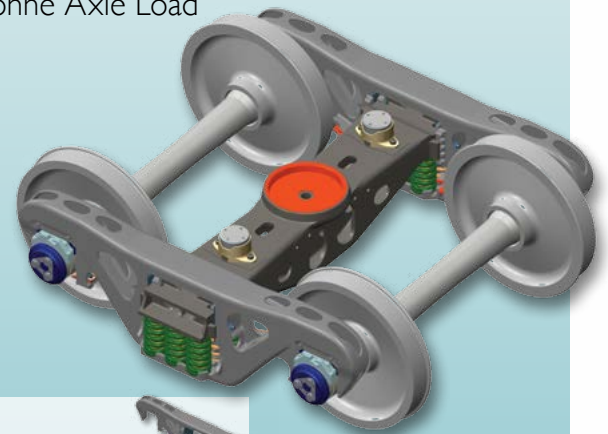

# Reliable Bogie Components

## Precision-engineered innovation

At Amsted Rail, we provide more than parts: We deliver performance. We lead the way in supplying the highest quality, most reliable bogie components. No matter where in the world you're hauling freight, Amsted Rail's heritage of manufacturing and trust ensures your sensitive cargo will get there in one piece.

### Friction Wedges

Our highly engineered friction damping systems improve ride quality and bogie performance, providing a longer lifecycle for wagon components



### Coils

Coil Springs from our state of the art manufacturing facility provide unparalleled quality and reliability



### Adapter Plus®

Adapter Plus enables steering and provides 25% longer wheel wear life, and longer roller bearing life than other bearing adapters



### PreLoad Plus® Constant Contact Side Bearing

PreLoad Plus retains over 95% of its new condition preload after hundreds of thousands of miles, providing significantly longer service life than conventional CCSB's



### Bearings with Low Torque Seal and Tru-Fit Backing Ring

Brenco® Bearing options provide better fuel efficiency and fewer fretting replacements with higher reliability and longer life



### Wheels

Griffin® Wheel casting process ensures steel cleanliness, and consistent tape size and rim thickness for world class quality and reliability



### Axles

Axis Axles provides the highest quality axles to the most exacting standards from the world's most technologically advanced axle manufacturing facility

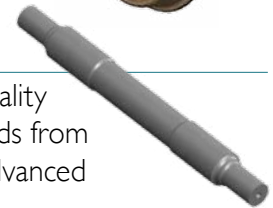

### Wear Prevention Products

Hollube® and Hollamax® Wear Prevention Products are made with an advanced plastic strong enough to outlast steel and proven to reduce wear up to 88%



## IONX® Asset Monitoring – 24/7 Remote Management

IONX asset monitoring systems enable you to better manage your fleet, providing data that can help you improve shipment safety, security, turn cycles and total fleet optimization. IONX delivers location and condition status reports in near real-time – regardless of your asset's location – and complies with all federal government reporting requirements. Insights gained from IONX analysis are helping shippers and owners around the world reduce costs and meet productivity goals.



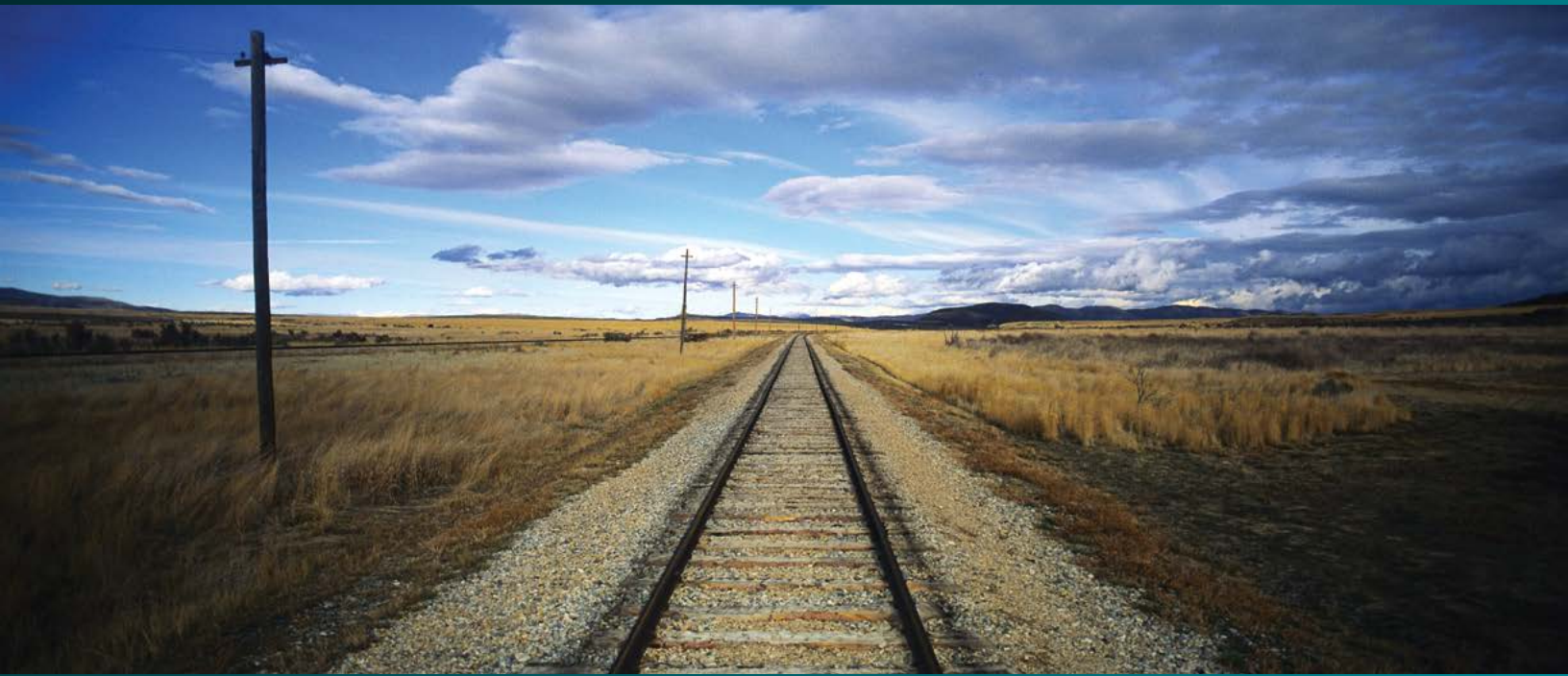

**Amsted Rail, the global leader  
in fully integrated freight car systems  
for the heavy haul rail market.**



Amsted Rail has been an industry leader in freight railroading for more than 100 years. Our experience, dedication and efficiency in servicing today's demanding heavy haul operations is unequaled as we keep railcars rolling in some of the world's toughest railroad environments. To learn more, visit [www.amstedrail.com](http://www.amstedrail.com).

**Amsted Rail**<sup>®</sup> *A world apart in reliability*

[www.amstedrail.com](http://www.amstedrail.com) | +1.312.922.4501 | 311 S.Wacker Drive, Suite 5300, Chicago, IL 60606  
© 2014 Amsted Rail Company, Inc.