

## 1. Introduction

Our EZ Encoders effectively eliminate multiple encoder part numbers by bringing intelligence and security to the design. A four-digit LED display with two push-buttons enables the user to change its resolution (counts per turn) as well as set a password to protect unauthorized changes within seconds, conveniently eliminating the need for PCs or external devices for programming.

Additional features of the EZ25 encoder include reverse voltage protection of the inputs and short circuit protection of the outputs with automatic thermal shutdown. This encoder is designed to operate within a wide range of industrial applications under harsh environmental conditions such as mechanical shock, vibrations, extreme temperature and humidity changes, oil mists, coolants and solvents. Nema 4 and 4x rated, submersible and explosion proof, Class 1, Div 1 models are also offered to suit a virtually limitless number of applications. The EZ Encoder is available with the most common connectors found on the market making it a universal drop-in replacement for hundreds of brands of encoders for a fraction of the price.

## 2. Specifications

### ELECTRICAL

#### INPUT POWER

Voltage: 18-32 VDC  
Current: 100 mA @ 24VDC (without any load)  
High Voltage: Min. 2.4VDC TTL Compatible  
Low Voltage: Max. 0.4VDC TTL Compatible

#### OUTPUT DRIVERS

Line Driver Device: ET7272  
Voltage:  $30V/V = 18-30VDC (V_{in} = V_{out})$   
 $30V/5 = 5VDC$   
Max Output Current: 40mA  
High Voltage: 30 VDC @ 20mA source current  
Low Voltage: 5 VDC @ 20mA sink current

#### OUTPUT FORMAT

**Gray Code:** Programmable up to 4096  
**Binary:** Programmable up to 4096  
**BCD:** Programmable up to 1999

#### DATA SYNCHRONIZATION

The EZ Encoder Absolute Resolver continuously updates its position. Since the device is Level Triggered, the encoder position is latched on as long as the Data Transfer command from the Programmable Controller is OFF (i.e. the level is "Low"). It can then be read back by the Programmable Controller. At the same time, the data constantly updates itself if the level of the Data Command is "High".

#### PROTECTION

Reverse Voltage Protected Inputs  
Short Circuit Protected Outputs

#### POWER-ON SETTling TIME

Upon power-up the outputs are tri-stated for up to 100mSec.

### ENVIRONMENTAL

Housing	Size 25 (2.5" dia.)
Depth	3.12"
Shaft Size	3/8"
Max. Slew Speed (RPM)	5000
Max. Starting Torque @ 25 °C (oz. in.)	5
Max. Shaft Loading Axial and Radial:	80 lb.
Bearing Life at Max. Mfr. Spec.	$1 \times 10^9$
Shock	100g for 11ms
Vibration	20g to 2000Hz
Enclosure	NEMA 4/IP 65
Operating Temperature	-10°C to 70° C
Storage Temperature	-40°C to 85°C

## 3. Wiring

- The shielded interconnecting cable should be routed in its own conduit and kept separate from other high voltages/high inductance wiring. The shield drain wire should be connected to earth ground at both ends of cable.
- Follow the wiring diagram below:

### CAUTION:

- Upon power-up the outputs are tri-stated for up to 100mSec.
- Check the cable wiring before applying power.

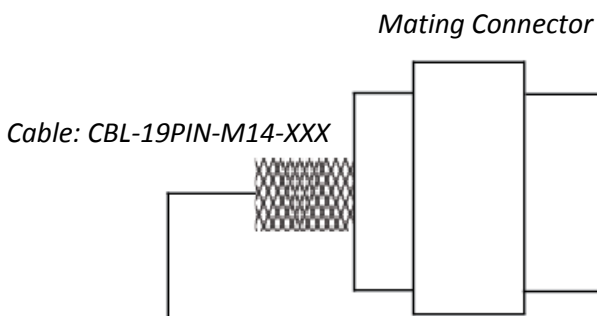

19-pin Connector

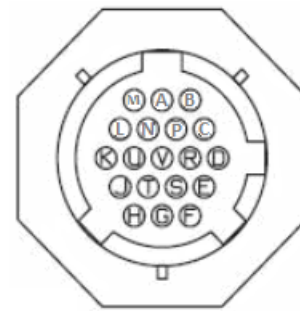

Connector Pin	Cable CBL-19PIN-M14-XXX	Digital Output		
		BCD	Binary	Gray
A	Black	1	B11 (MSB)	G11(MSB)
B	White	2	B10	G10h
C	Grey	4	B9	G9
D	Violet	8	B8	G8
E	Blue	10	B7	G7
F	Green	20	B6	G6
G	Yellow	40	B5	G5
H	Orange	80	B4	G4
J	Red	100	B3	G3
K	Brown	200	B2	G2
L	White/Yellow	400	B1	G1
M	White/Orange	800	B0 (LSB)	G0 (LSB)
N	White/Brown	1000	Not Used	
P	White/Red	2000		
R	White/Green	Not Used		
S	Shield	Case Ground		
T	Black/12 gauge	- V (Common)		
U	White/Black	Data Transfer (PC sync)		
V	White/12 gauge	+ V (Supply VDC)		

## 4. Mounting

### Types of Mounting

#### 1. Servo-Mount / Face Mount

The EZ Encoder can be either mounted with traditional servo-clamps or through the four 6-32 mounting holes on the face of the resolver.

#### 2. Flange Mount

The EZ Encoder can be mounted using the four mounting holes on the square faceplate.

### Mounting Dimensions

#### Flange Mount

Units: [mm]  
inches

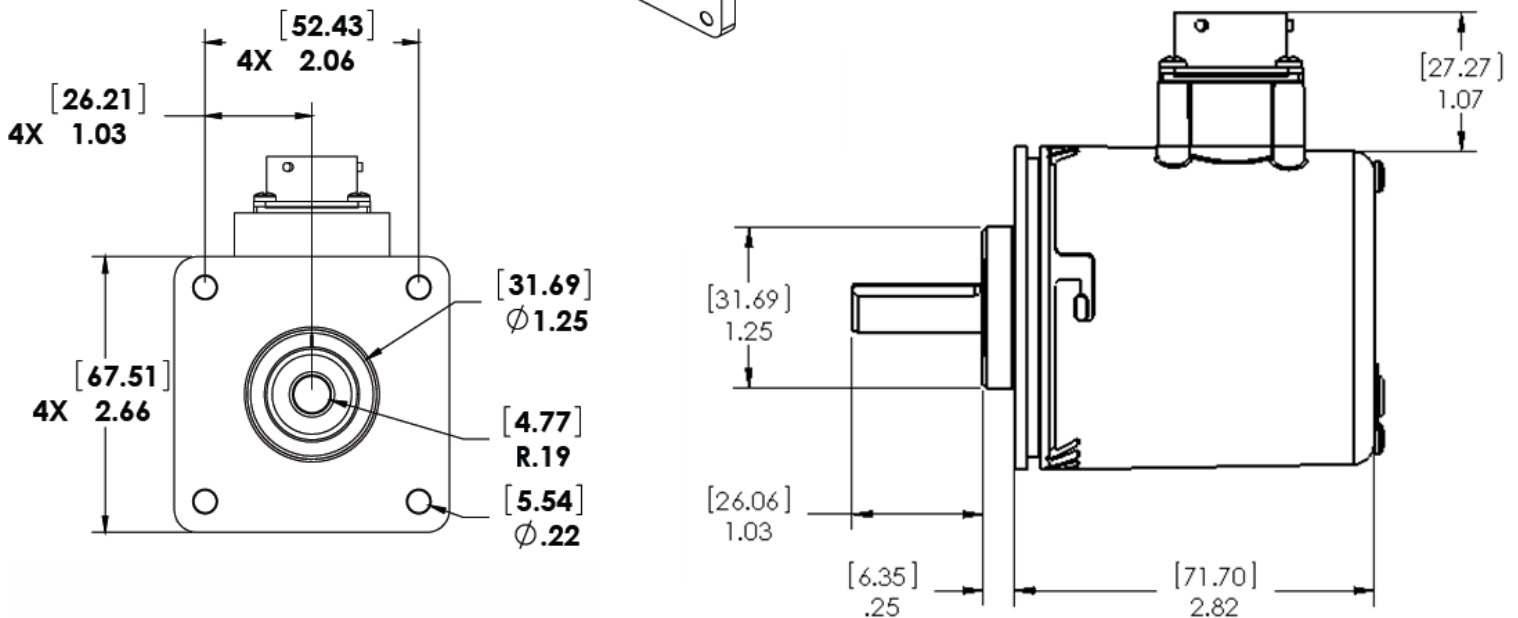

# EZ Encoder : Resolver Absolute (P Series)



Servo-Mount / Face Mount

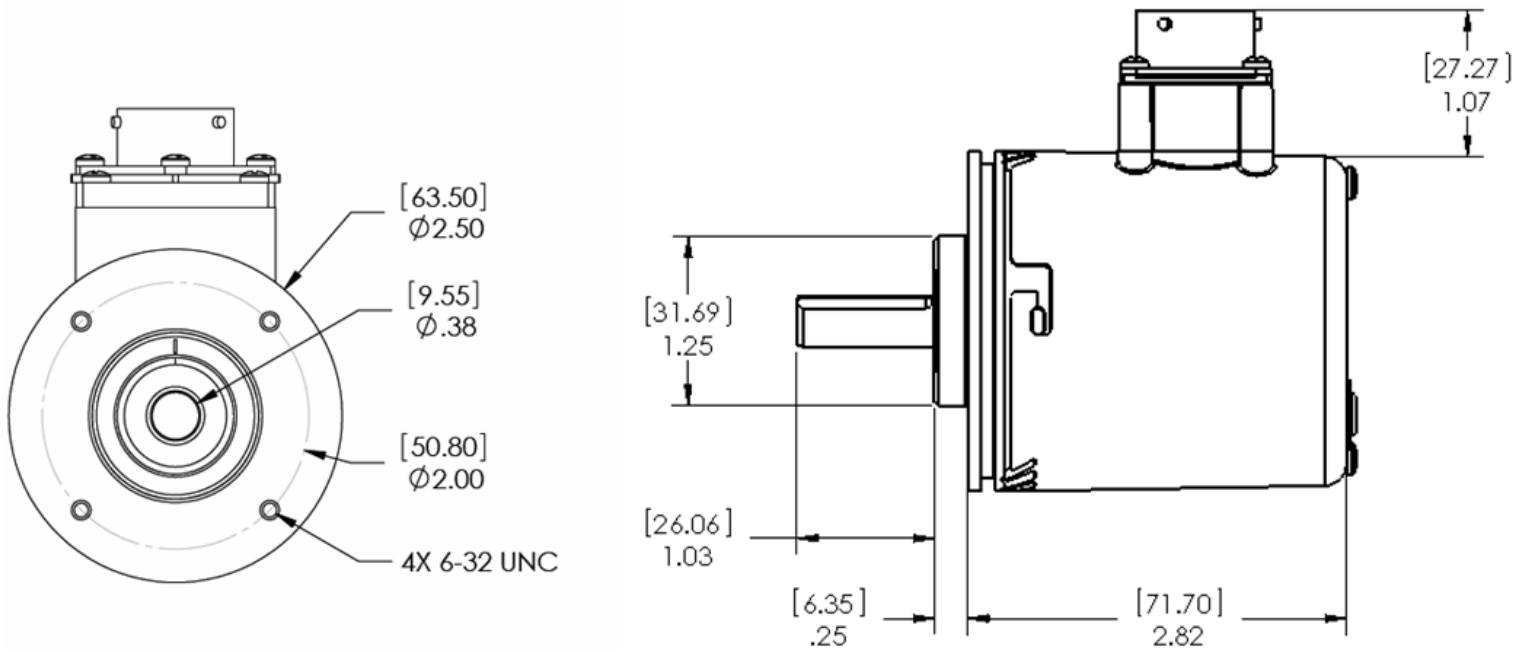

## 5. Programming

The EZ25 Encoders have a 7-segment LED Display (shown below) which can be used for programming the user parameters.

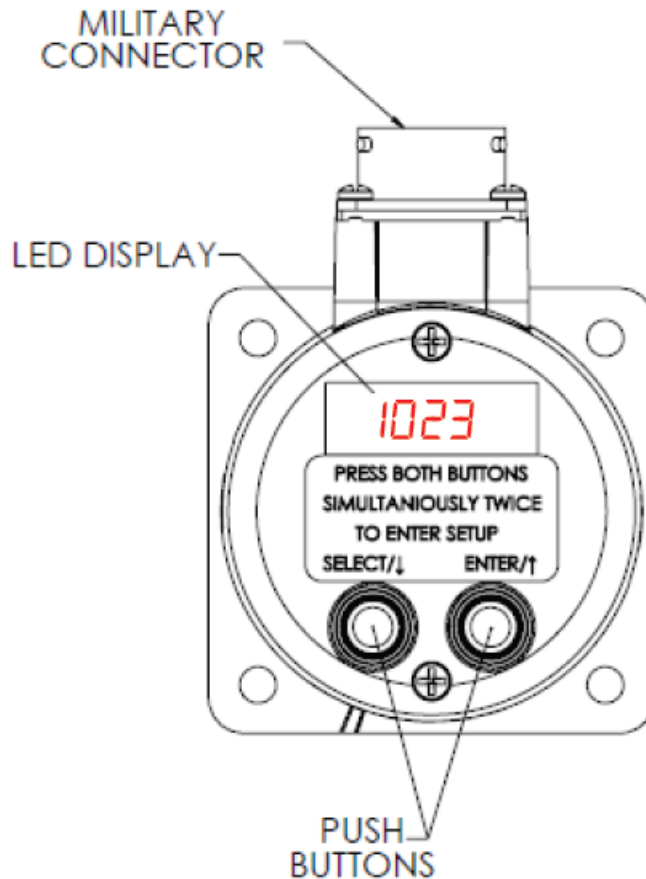

The EZ25 Encoders have two modes of operation: **Run Mode** and **Programming Mode**.

### 1. Run Mode

When in Run Mode the encoder will display the position of RPM (Revolutions Per Minute). To differentiate between the two parameters, the Resolver includes a decimal point following the right-most digit while displaying the RPM.

RUN MODE	EXAMPLE
Position	0344
RPM	0311.

#### Left Pushbutton:

Pressing the Left Pushbutton in run mode toggles between the position and RPM display.

#### Right Pushbutton:

Pressing the Right Pushbutton in the Run Mode provides the user with a quick overview of the resolver's parameters and their current settings. After automatically scrolling through the parameter values, the display returns to the Run Mode. The following parameters are displayed:

- uEr** - Firmware Version
- PSEt** - Position Set
- rES** - Resolution
- tYPE** - Type of Code
- d ir** - Direction of Rotation

## 2. Programming Mode

- To enter the Programming Mode, press both pushbuttons simultaneously twice.
- Use the left pushbutton to navigate through the parameters to be set.
- Use the right pushbutton to select the parameters to be programmed.
- Once a parameter has been selected, use the left pushbutton to decrement values and the right pushbutton to increment values.
- Next, press both pushbuttons simultaneously to save the changes, program the flash and return to Programming Mode.
- If there is 10 seconds of inactivity in Programming Mode, the encoder will discard the changes and return to Run Mode.

The following parameters are programmable:

Main Menu		
1.	Reset	rEST
2.	Position Set	PSEt
3.	Resolution	rES
4.	Output Format	tYPE
5.	Direction	d Ir
6.	Password Set	PASS

**Note:** If a password has been previously set, upon entering the Programming Mode the user is immediately prompted to enter the password. The LED display shows **PASS** momentarily and then **0000**. The left pushbutton decreases the value while the right pushbutton increases it. Once the desired value is set, press both pushbuttons simultaneously to enter the password.

- If an incorrect password is entered, the display prompts for the password once more.
- If an incorrect password is entered again, the display shows **bAd** briefly and then returns to Run Mode.

### Reset

In **rEST** mode, the display flashes the actual (scaled) offset and then displays **ZEro**. Pressing both pushbuttons at this time will set the current position of the encoder to zero and bring the EZ Encoder back to the Programming Menu.

### Position Set

In **PSEt** mode, the LED display shows the actual (scaled) position. The left pushbutton decreases the value while the right pushbutton increases the value. Pressing both pushbuttons simultaneously saves the current position value and brings the EZ Encoder back to the Programming Menu.

### Resolution

In **rES** mode, the encoder displays the current resolution (counts per turn). The left pushbutton decreases the value while the right pushbutton increases the value. Pressing both pushbuttons simultaneously saves the current resolution and brings the encoder back to the Programming Menu.

*Note: For Binary and Gray Code, the maximum programmable resolution is 4096. For BCD, the resolution can be programmed up to 1999.*

### Output Format

In **tYPE** mode, the encoder displays the current type of output code. There are three types of code to choose from:

Binary	b in
BCD	bcd
Gray Code	g-rY

By pressing any one of the pushbuttons, the user can navigate through the code types. Pressing both pushbuttons simultaneously will save the current type of code. Afterwards, the resolver will enter the resolution mode so the user can program the resolution according to the output type selected. Once done, the resolver returns to the next Programming Menu item (direction).

## Direction

In **dir** mode, the display shows the current direction of count. There are two directions to choose from: **CU** (clockwise) or **CCW** (counterclockwise). User can change the direction by pressing either pushbutton. Pressing both pushbuttons simultaneously will save the current direction of count and return the resolver to the Programming Menu.

## Password

In **PASS** mode, the encoder displays **On** to indicate a password on or **OFF** to indicate password feature disabled. Pressing any one of the pushbuttons toggles between password “on” and “off”. To disable the password feature choose **OFF** and press both pushbuttons simultaneously. The encoder will then return to Run mode. To enable the password protection choose **On**. The encoder then shows the current password stored in memory. The right pushbutton increases the value while the left pushbutton decreases it. When the desired value has been selected, press both pushbuttons simultaneously to save the new password and return to Run Mode.

\*For instructions on resetting the password please consult the factory .

## 3. Programming Example

This example will illustrate how to program the encoder with the following parameters: a resolution of 1024 pulses per revolution (PPR) and a password set to **1111**.

- Wire the encoder according to the wiring instructions on page 2 and supply the appropriate power.
- The encoder is now in Run Mode. Press the left pushbutton to see the RPM while rotating the shaft of the encoder.

- Press both pushbuttons twice simultaneously to enter Programming Mode. The LCD display will show **rES**.
- Press the right pushbutton to enter resolution set mode. Then use the left and right pushbuttons to decrease and increase the counts per turn respectively. Once you reach **1024** press both pushbuttons simultaneously to save the setting.
- The display will now show **TYPE**. Press the right pushbutton to enter the Output Format set mode. Press the left pushbutton until you see **bin**. Then press both pushbuttons simultaneously to save.
- The screen will now display **dir**. Press the right pushbutton to enter the direction set mode. Use either pushbutton to toggle the direction to **CCW** and then press both pushbuttons simultaneously to save.
- The encoder should now display the next programming option: the password **PASS**. Press the right pushbutton to enter password set mode.
- Use the left or right push buttons to toggle the password to **On**. Now press both of the pushbuttons simultaneously to save the setting.
- The screen will now display **0000**. Using the right pushbutton, increment the password to **1111**. Press both pushbuttons to save the password.
- The encoder is now back in Run Mode.

This completes the programming example. You may check the resolution by pressing the right pushbutton while in run mode.

To enter programming mode use password **1111**.

## 4. Programming Flowchart

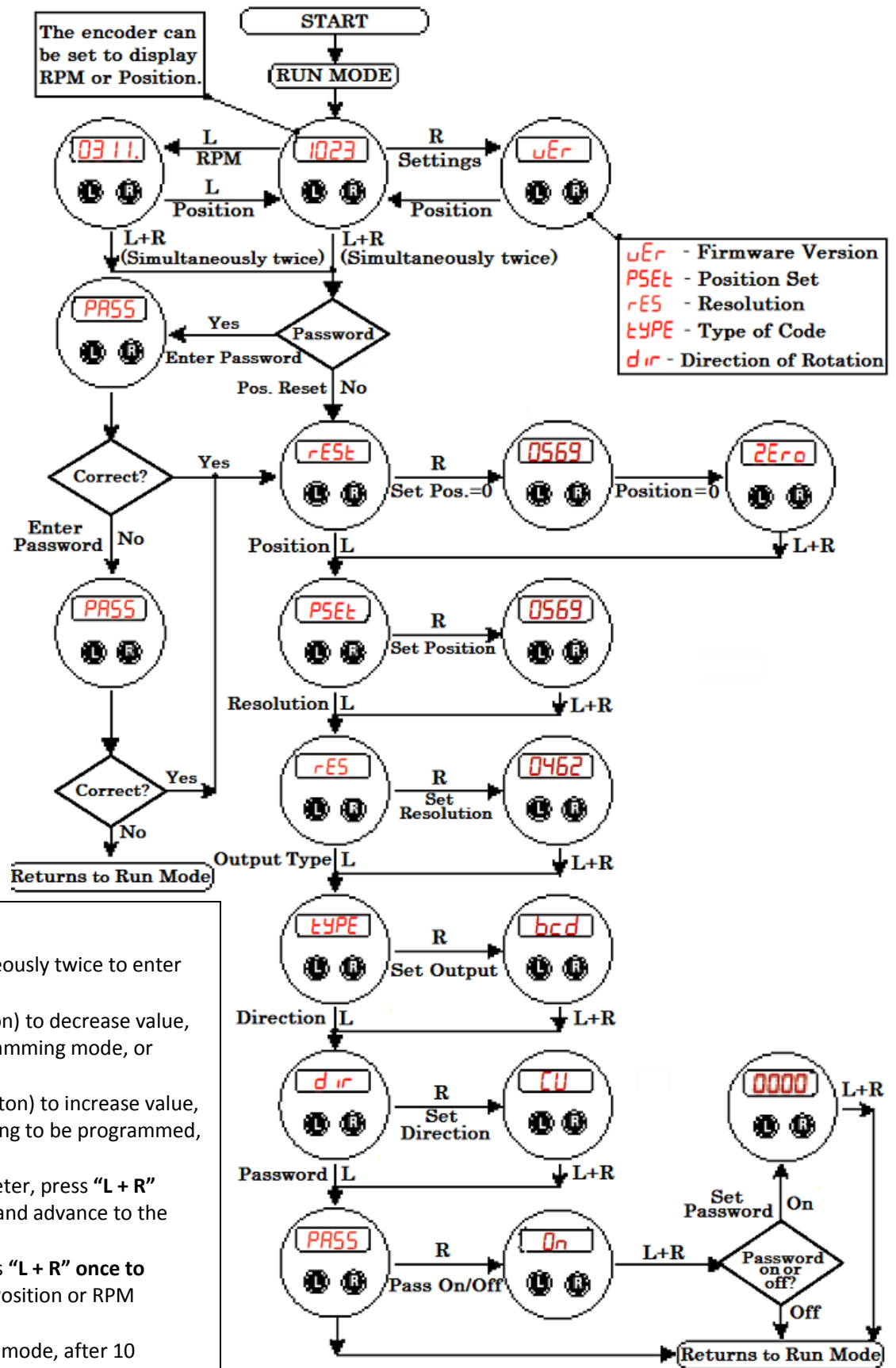

### NOTES

- Press "L + R" simultaneously twice to enter programming mode.
- Use "L" (left pushbutton) to decrease value, advance to next programming mode, or toggle settings.
- Use "R" (right pushbutton) to increase value, select the current setting to be programmed, or toggle settings.
- While setting a parameter, press "L + R" **once to save changes** and advance to the next mode.
- While navigating, press "L + R" **once to return to Run Mode** (Position or RPM Display).
- While in programming mode, after 10 seconds of inactivity the encoder will return to Run Mode.



## 6. How to Order

---

**EZ25<sub>1</sub>X – PRGA – XXXX<sub>2</sub> – 19D – M14**

### 1. Mounting Type

- S Servo or Face Mount
- F Flange or Face Mount

### 2. Input Power / Output Driver

- 30V/V 10-30Vin,  $V_{in}=V_{out}$
- 30V/5 10-30Vin,  $V_{out}=5V$