

CABLE REELS



United Equipment Accessories, Inc.
Solving Challenges from the Inside Out.™

CABLE REELS

United Equipment Accessories' unmatched flexibility in slip rings is available in combination with our heavy-duty cable reels. UEA cable reels were first introduced to the market in 1982. In addition to the standard 3 and 4 conductor models commonly used, we are known for our ability to meet virtually any specific cable reel need with our custom applications.

Heavy-duty cable reels for any application

Today, we serve a variety of industries located around the world with our cable reel, slip ring, shift control and hydraulic swivel product lines. United Equipment Accessories specializes in providing custom electric cable reels. We can also fill many requirements outside the standard reels shown in this literature, including hose reels and other reel body styles. Our engineers will work with you to select the cable reel model and options that will best meet the specific needs of your application.

Our corporate headquarters and manufacturing facility is located in Waverly, Iowa. This central location in America's heartland enables us to efficiently supply our products to industries throughout the United States and around the world.

Standard Cable Reel Features:

- Cable standard SOW-A
- 5' of stationary cable length included
- Adjustable cable bumpers allow varying cable length outside the reel
- Latch mechanism guarantees extended cable will lock at desired length
- Constant tension reels available
- Varying guide arm positions allow floor, wall, ceiling or any custom mount
- Spring motor gasket ensures long life
- Nylon guide rollers eliminate cable pinching and reduce drag



Providing solutions for a wide range of heavy-duty industrial applications, UEA cable reels serve applications in many types of industries. They can be mounted several different ways, so efficiency is maximized in the workplace and in production. Our cable reels are available in a variety of standard sizes to meet job demands. For special one-of-a-kind applications, UEA also supplies custom reels.

Cable Reel Applications

- Aerial Work Platforms
- Conveyor Systems
- Overhead Cranes
- Crane Anti-Two Block & Overload Systems
- Forklifts
- Forestry Equipment
- Garage Doors
- Hoists
- Light Towers
- Jib Cranes
- Material Handling Systems
- Sliding Gates
- Robotic Welding Cells
- Rough Terrain Cranes
- Teach Pendant Cable Controls
- Theatrical and Stage Sets
- Truck Body/Service Cranes
- Truck Mounted Cranes
- Work Platforms
- Various Other Industrial Applications

Don't see your application listed? We can still help! We offer custom cable reels for a wide variety of applications. Our engineers will work with you to find a solution for your application.

40 SERIES - Compact Spring Driven Models

When you need a high quality cable reel that's small on size yet big on power, take a closer look at UEA's 40 Series. It's half the size of our larger 90 Series, making it the perfect choice when you have limited space for reel mounting or if you require a small diameter cable reel.

- R40 reel is perfect for small diameter (up to 0.375") cable up to 50 feet
- R44 and R46 reels have shorter length, larger diameter cable

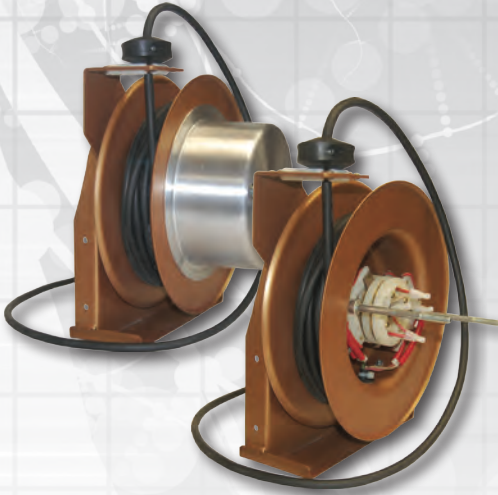

Model No. Standard Model	Max. Length	Wire Ga.	No. of Conductors	Std. SOW-A Cable Dia.
R46L6P3	30'	16	3	0.390
R46L6P4	30'	16	4	0.420
R46L6N3	30'	14	3	0.540
R46L6N4	30'	14	4	0.580
R44L8P3	40'	16	3	0.390
R44L8P4	40'	16	4	0.420
R46L5M3	25'	12	3	0.600
R46L4M4	20'	12	4	0.650
R46L3L3	15'	10	3	0.660
R46L2L4	10'	10	4	0.720

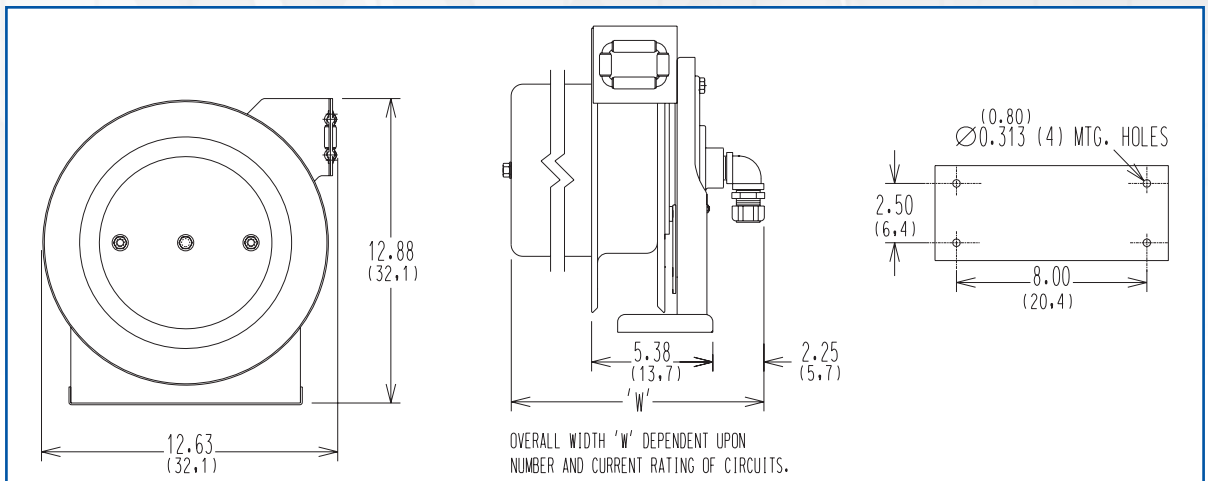

50 SERIES - Small Capacity Spring Driven Models

Looking for a small yet heavy-duty reel? The 50 Series is your answer! With a larger spool capacity than the 40 Series, but a more compact size than the 70 Series, this reel is able to meet many of your smaller-size application needs.

- Ideal for multi conductor count cables of 5 or more
- Larger spool capacity for longer, heavier O.D. cable up to .73"
- Available in stainless steel to help with corrosive environments

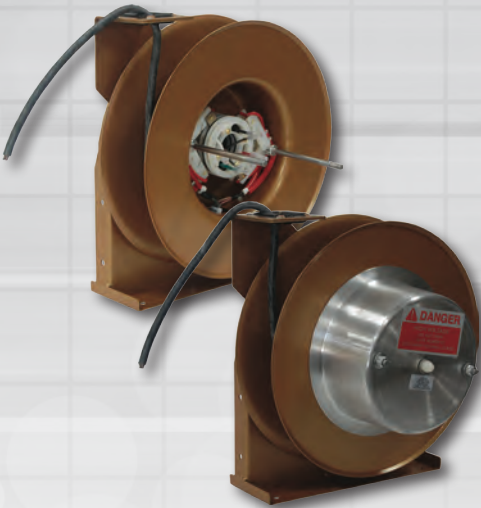

Model No. Standard Model	Max. Length	Wire Ga.	No. of Conductors	Std. SOW-A Cable Dia.
R56L8P3	40'	16	3	0.390
R56L9P4	45'	16	4	0.420
R56LAN2	50'	14	3	0.540
R56L9N4	45'	14	4	0.580
R58L6P3	30'	16	3	0.390
R58L6P4	30'	16	4	0.420
R58L8N3	40'	14	3	0.540
R58L8N4	40'	14	4	0.580
R58L8M3	40'	12	3	0.600
R58L7M4	35'	12	4	0.650
R58L6L3	30'	10	3	0.660
R58L5L4	25'	10	4	0.720

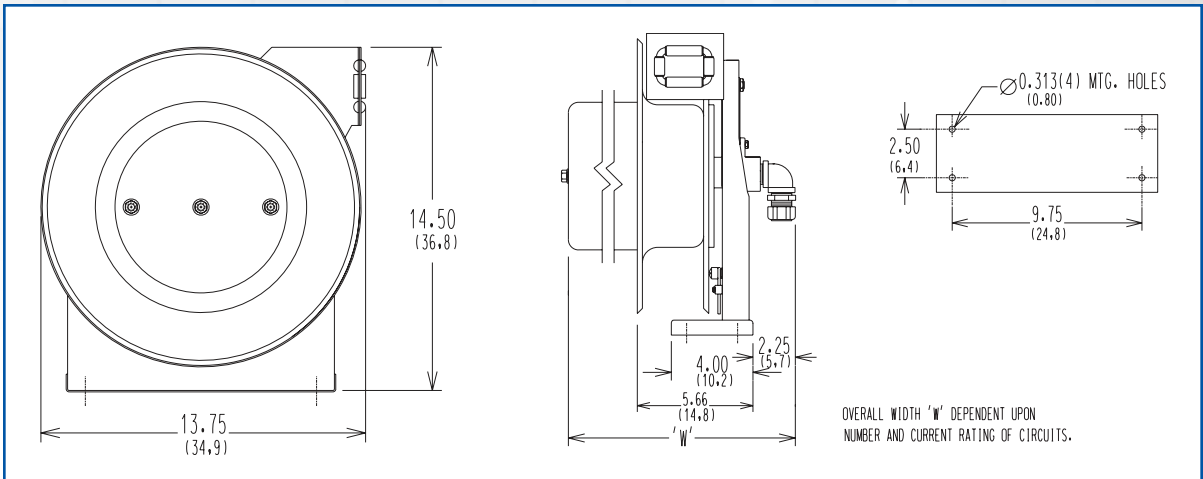

70 SERIES - Medium Capacity Spring Driven Reel

Model No. Standard Model	Max. Length	Wire Ga.	No. of Conductors	Std. SOW-A Cable Dia.
R76LBP3	55'	16	3	0.390
R76LCP4	60'	16	4	0.420
R76LDN3	65'	14	3	0.540
R76LEN4	70'	14	4	0.580
R76LFM3	75'	12	3	0.600
R76LEM4	70'	12	4	0.650
R77L9P3	45'	16	3	0.390
R77LAP4	50'	16	4	0.420
R77LBN3	55'	14	3	0.540
R77LCN4	60'	14	4	0.580
R77LDM3	65'	12	3	0.600
R77LCM4	60'	12	4	0.650
R77LBL3	55'	10	3	0.660
R78L8P3	40'	16	3	0.390
R78L9P4	45'	16	4	0.420
R78LAN3	50'	14	3	0.540
R78LBN4	55'	14	4	0.580
R78LCM3	60'	12	3	0.600
R78LBM4	55'	12	4	0.650
R78LAL3	50'	10	3	0.660
R78LAL4	50'	10	4	0.720

This medium-sized reel series has **built-in versatility to get the job done.** Compared to our smaller reel series, this reel can hold cable up to 75' and accepts cable/conductor diameters up to .875" O.D. This reel is extremely versatile, which makes the 70 Series one of United Equipment's most popular models.

- Designed to handle heavy-duty applications
- Narrow profile reel takes up less space
- Available in stainless steel to help with corrosive environments

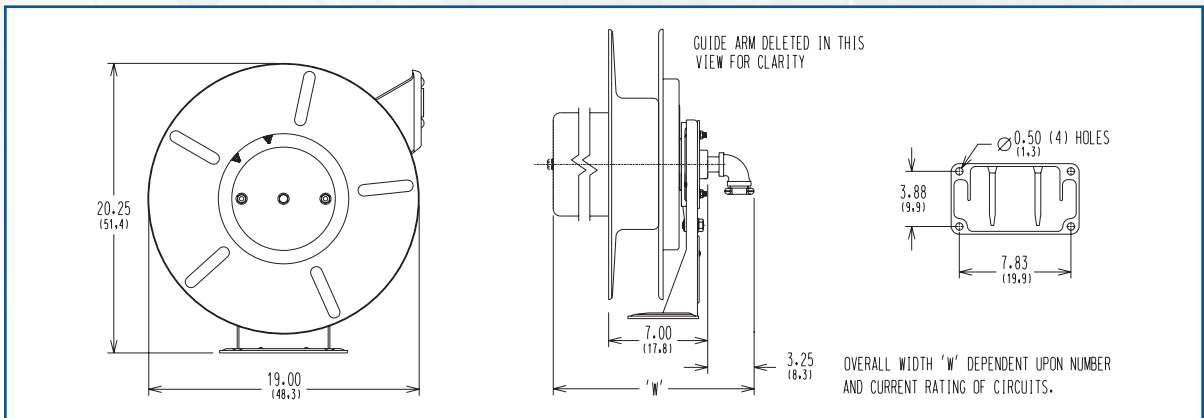
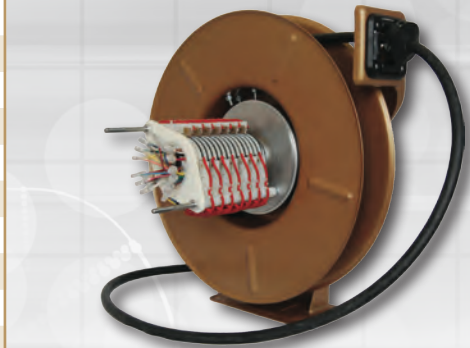

80 SERIES - Large Capacity Spring Driven Reel

The 80 Series reel features **rugged durability to handle the rough jobs**. This reel offers the longest extension of cable up to 100'. With versatile mounting options and multiple circuit ratings available, this series is perfect to meet many different specifications.

- Dual support saddle frame for structural strength
- Accepts cable up to .875" O.D.
- Spring motor options with different torque ratings
- Available in stainless steel to help with corrosive environments

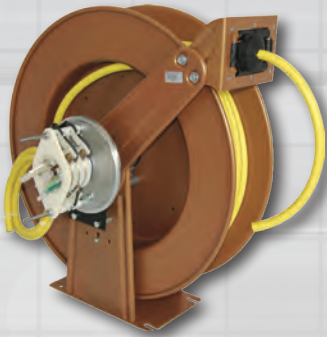

Model No. Standard Model	Max. Length	Wire Ga.	No. of Conductors	Std. SOW-A Cable Dia.
R83LKP3	100'	16	3	0.390
R83LKN3	100'	14	3	0.540
R83LKM3	100'	12	3	0.600
R83LKL3	100'	10	3	0.660
R83LKP4	100'	16	4	0.420
R83LKN4	100'	14	4	0.580
R83LKM4	100'	12	4	0.650
R83LKL4	100'	10	4	0.720

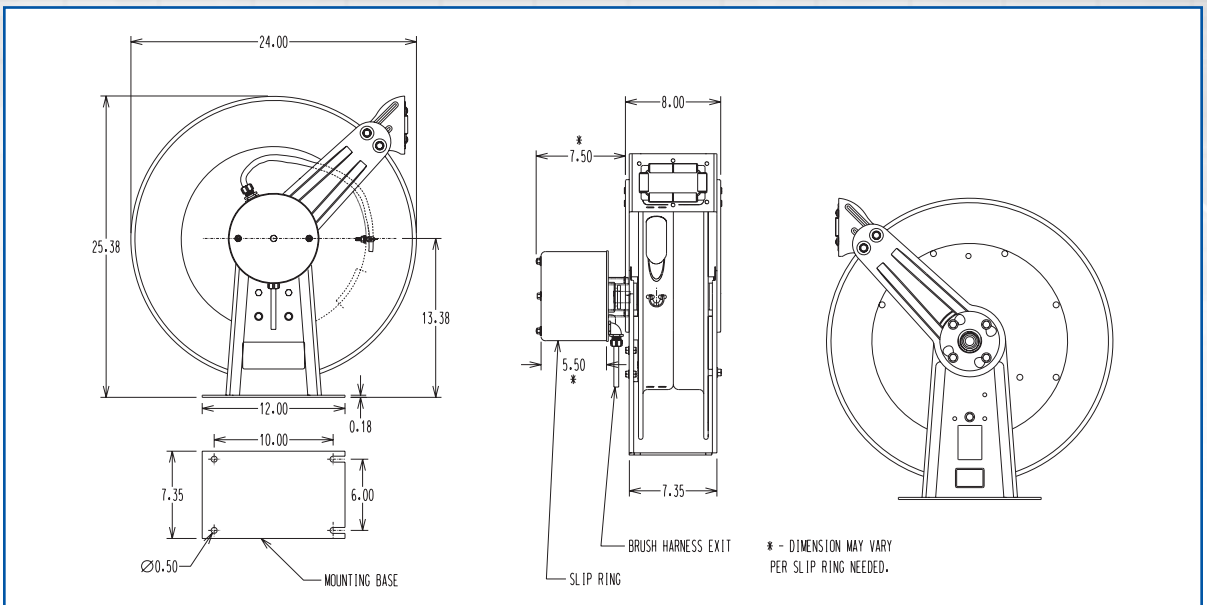

90 SERIES - Extra Large Capacity Spring Driven Reel

Make no mistake - **this is the big one!** The 90 Series is perfect when you need a reel that can handle longer cable lengths with large diameter cable. With the capability to handle cable up to 1.33" O.D., this reel can manage what most reels can't.

- Heavy dual support design for structural strength
- Multiple spring motor torque options
- Available in stainless steel to help with corrosive environments
- High power circuit rating options allow for higher amperages

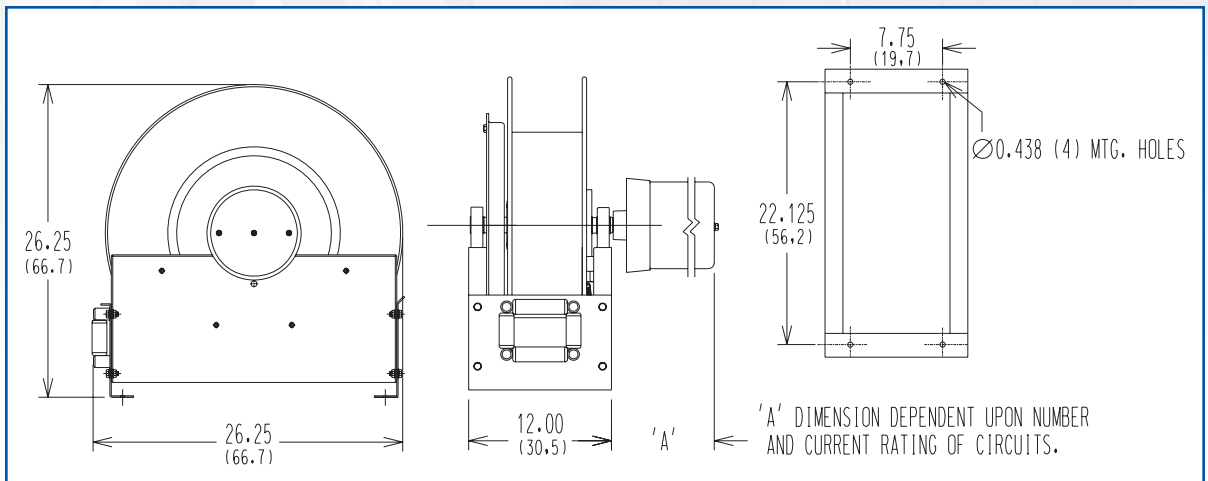
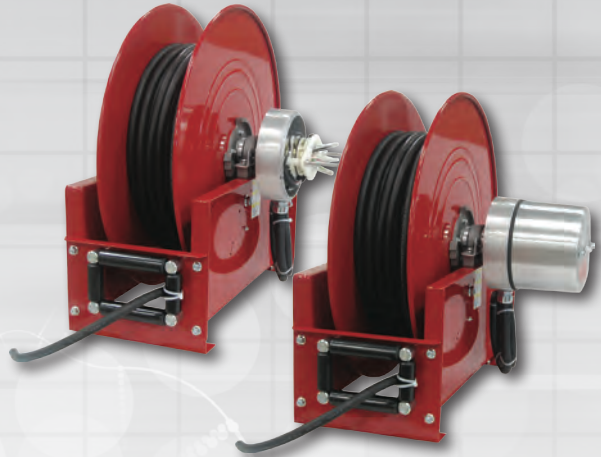

TEACH PENDANT CABLE REELS - Robotic Cable Management

Increase the life of your cable!

- Cable reels prevent the cable from being left on the ground and ruined by machinery
- Enjoy long-term cost savings with less cable replacement and labor costs
- Promote safer work environment that reduces hazards within the plant
- Reels handle virtually any type of communication circuits through our slip ring assemblies
- UEA can build the slip ring with any combination and number of circuits to meet the exact requirements of the control system being used
- Customized cable reels to meet our customer requirements including with UEA or customer supplied cable

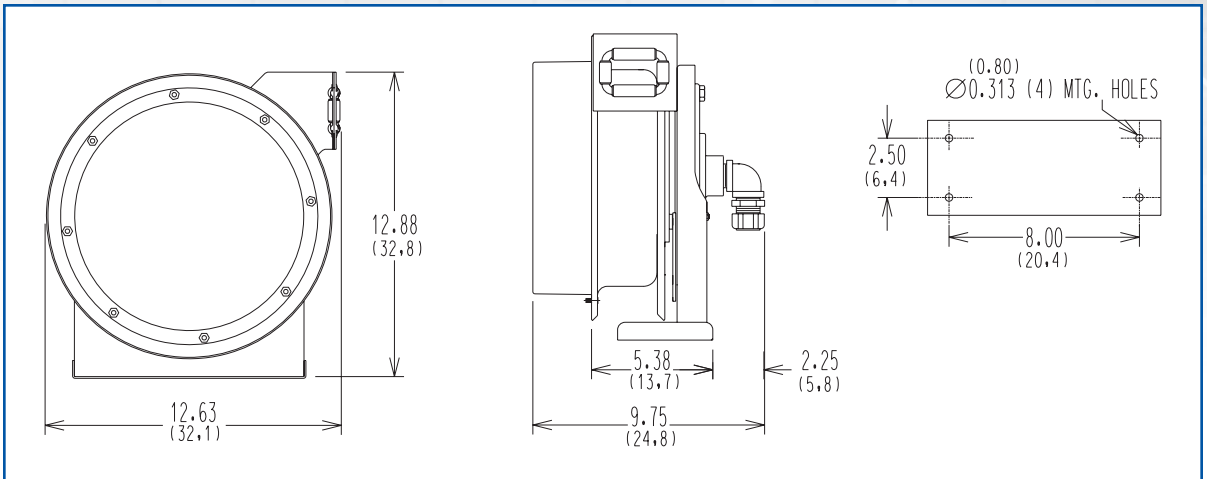
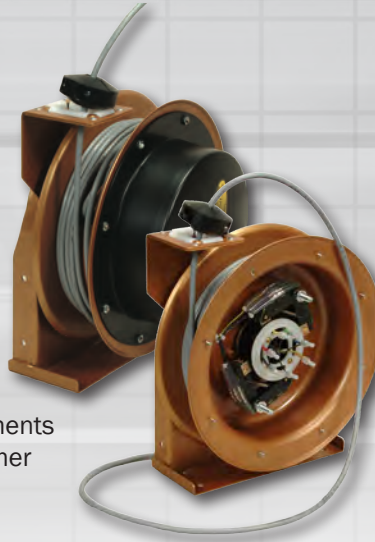

MOTORIZED REELS - Motorized Rewind Reels

The 30 Series motorized reels are equipped to handle applications that require numerous extension and retraction cycles. It's the reel that **works all day, every day**. With multiple circuit rating options and the capability to manage over 100' of cable, motorized reels can be adapted to fit your needs.

- Reel options include, air, electric or hydraulic motors
- Motor designed for heavy-duty usage
- Rugged dual triangular support with shaft bearings
- Multiple spool width options: Choose from 6", 12", 18", 22" or 27"
- Larger diameter cable capability up to .875" O.D.
- Low profile for critical space requirements
- Lock pin to prevent free spooling
- Available for pneumatic reels as well

Part Number	Dimension A	Dimension B	Dimension C	Dimension D
R35P (120 VAC)	31.50"	27.00"	37.00"	30.75"
R34P (120 VAC)	26.50"	22.00"	32.00"	25.75"
R33P (120 VAC)	22.50"	18.00"	28.00"	21.75"
R32P (120 VAC)	16.50"	12.00"	22.00"	15.75"
R31P (120 VAC)	10.50"	6.00"	16.00"	9.75"
R35E (12 VDC)	31.50"	27.00"	37.00"	30.75"
R34E (12 VDC)	26.50"	22.00"	32.00"	25.75"
R33E (12 VDC)	22.50"	18.00"	28.00"	21.75"
R32E (12 VDC)	16.50"	12.00"	22.00"	15.75"
R31E (12 VDC)	10.50"	6.00"	16.00"	9.75"

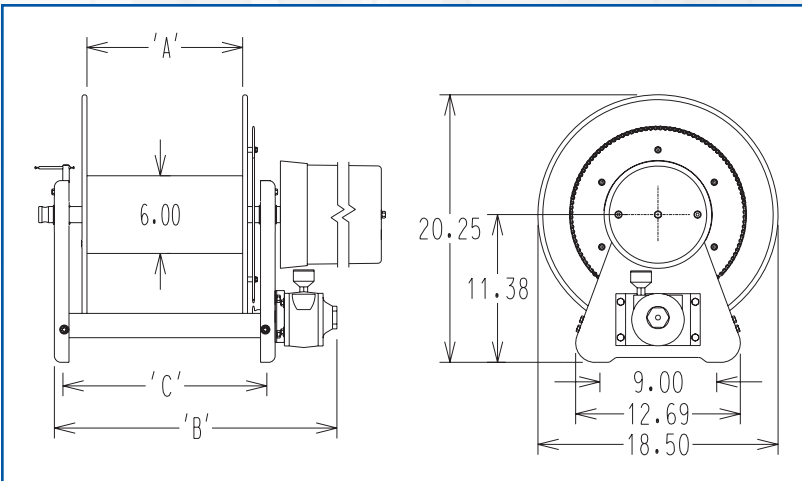

MANUAL REELS - Manual Rewind Side Crank Reels

The 30 Series manual reels feature **more options for greatest flexibility**. These reels allow for cable length that extend over 100'. Manual reels are ideal for those applications that require fewer extension and retraction cycles.

- Provided with standard side crank drive with optional front bevel crank available
- Rugged dual triangular support with shaft bearings
- Multiple spool width options: Choose from 6", 12", 18", 22" or 27"
- Larger diameter cable capability up to .875" O.D.
- Low profile for critical space requirements
- Lock pin to prevent free spooling
- Front bevel crank handle available

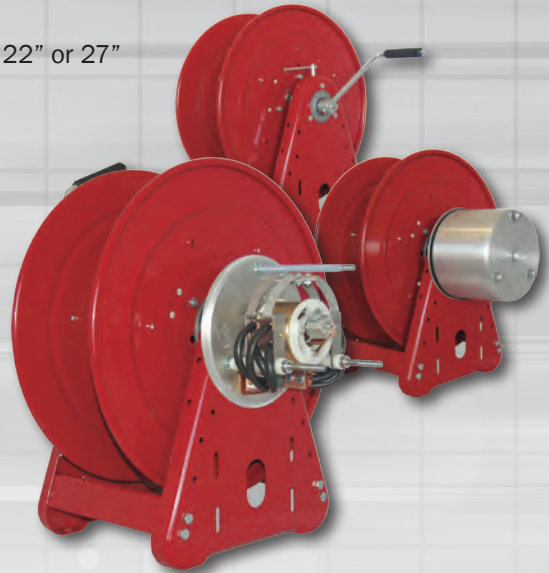

Part Number	Dimension A	Dimension B	Dimension C
R35H	31.50 (80.0)	27.00 (68.6)	30.75 (78.1)
R34H	26.50 (67.3)	22.00 (55.8)	25.75 (65.4)
R33H	22.50 (57.2)	18.00 (45.7)	21.75 (55.3)
R32H	16.50 (41.9)	12.00 (30.5)	15.75 (40.0)
R31H	10.50 (26.7)	6.00 (15.3)	9.75 (24.8)

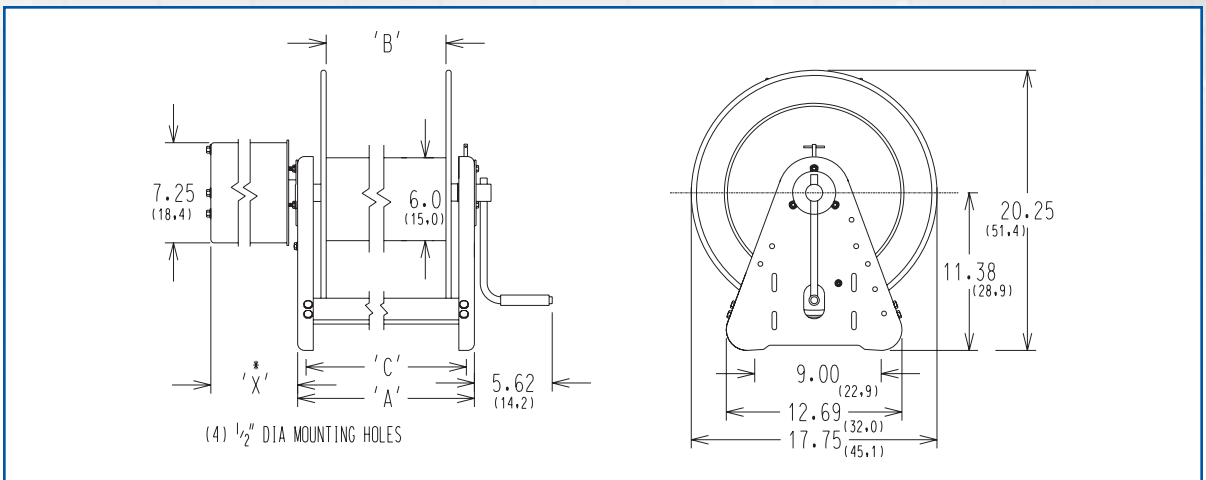

ACCESSORIES - Specialty Selections for All Reels

- 340° pivot base assemblies for 40, 50, 70, 80, 90 and 30 (6" & 12") Series
- Wall mount brackets for 40, 50, 70 and 80 Series
- Various receptacle options
- Speed controls
- Cable bumpers for latching reels
- Chain shrouds for 30 Series
- Circuit breaker
- Duplex boxes
- Various plug options
- Fluorescent light
- Hand carts for manual reels
- Momentary contact switch for electrical driven models
- Work light
- Various strain relief options

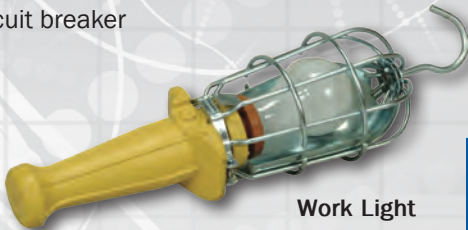

Work Light



Fluorescent Light



340° Pivot Base



Duplex Box



Wall Mount Bracket

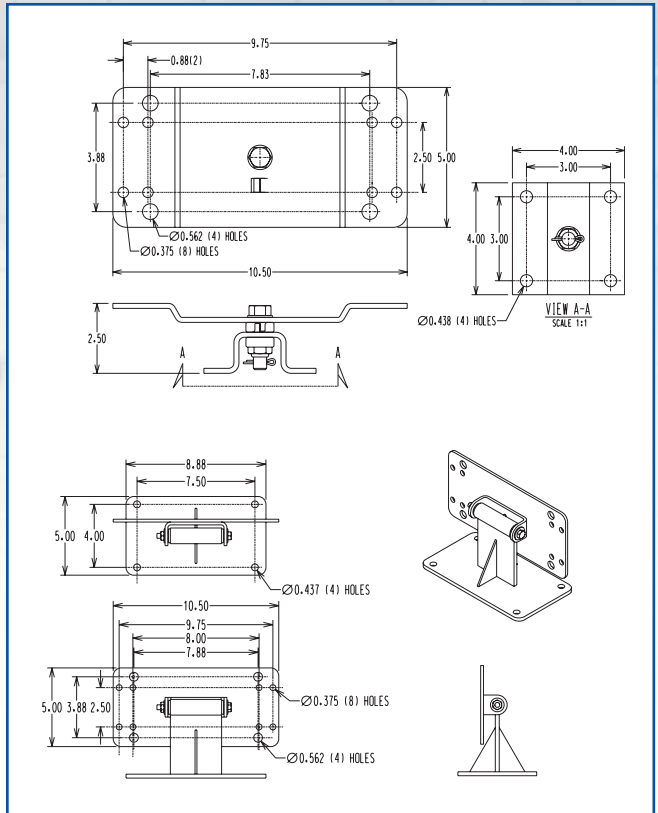

UEA SLIP RINGS - High Performance with Exceptional Quality

UEA slip rings have excellent low-level electronic circuit compatibility and are a reliable and efficient link to carry power, control, or signal circuits from stationary to rotating elements. UEA slip rings are built to handle all your application needs.

- Choice of bore size .5"-14"
- 1-75 or more circuits with many voltage (AC or DC) and amperage combinations
- Patented double pivot brush design that provides superior cleaning action assured by high contact pressure
- Two copper graphite brushes on each copper alloy ring circuit
- Coin or plated silver rings and silver graphite brushes available for low level signals
- Optional pre-wired harnesses
- Optional 1.5" bore rotational position sensing systems
- Pneumatic or hydraulic lines can be run through center bore
- Superior quality for hostile environments



CUSTOM CABLE REELS - Built the Way You Need It

UEA specializes in providing custom cable reels. We can handle many requirements for specific cable reels outside of the standard reels shown in this catalog. UEA can help with your specific application needs.

- Teach pendant reels provide reliable transmission of Profibus, DeviceNet, CC-Link, Control Net, J1939 CAN and other sensitive signal data
- Bar code wanding reels can be used for inventory control in warehouses and shipping and receiving locations
- Anti-two block reels help provide mobile lifting equipment safety

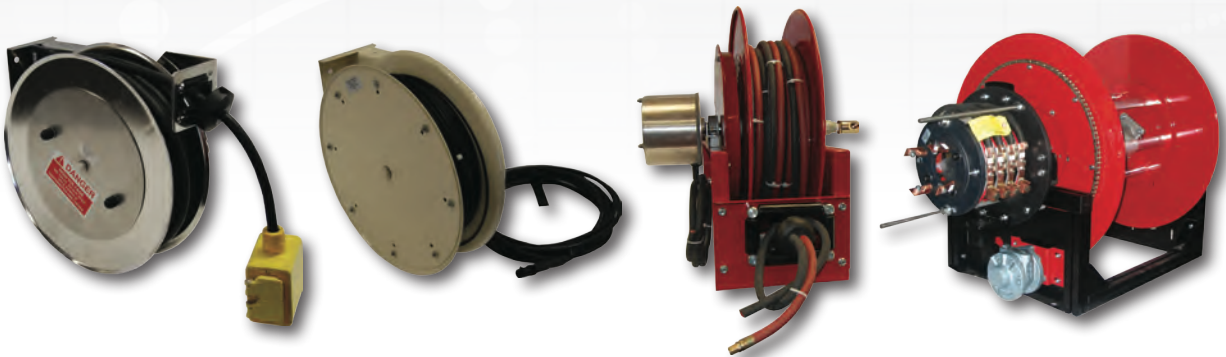

CABLE REEL SELECTION - How to Select the Right Cable Reel

In order to use the cable reel selection charts, first determine your mechanical, electrical and cable length requirements. Follow these three steps to ensure you get the best reel for your application needs. Your local representative or the sales team at our factory are happy to help if you need additional assistance.

1. Mechanical Requirements

- How will the reel be used? Stretch, lift, drag or retrieve? (see illustrations provided)
- What type of environment will the reel be located in? (indoors, outdoors, corrosive environment)
- How often will the reel payout and retract?
- Is the reel latching or constant tension?

2. Electrical Requirements

- How many total conductors are required? (Please include one conductor for dedicated ground.)
- How much amperage is the cable reel expected to handle?
- At what voltage?
- What gauge of cable is required? The amperage will determine the gauge.
- What will the reel be required to handle: power, control or communication signals?

3. Cable Length Requirements

- Is UEA supplying the cable? If yes, how much active cable is needed on the reel?

Drag: The reel is usually stationary with the cable being 'dragged' along a horizontal surface or through supports. Spring tension must be approximately the same as for a lift application. This type of application generally produces the greatest wear on the cable and the shortest cable life.

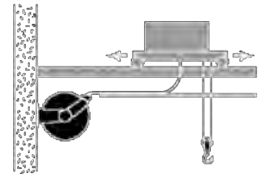

Lift: The cable extends and retracts vertically below the reel. Spring tension must be adequate to lift the full weight of the cable plus any additional weight attached to it, such as a pendant station, electrical outlet box, etc.

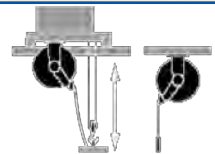

Retrieve: The reel is mounted on a moving carrier and picks up or recovers the cable from a horizontal tray or other surface. Less spring tension is required the closer the reel is to the recovery surface.

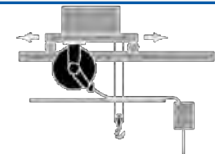

Stretch: The cable is suspended horizontally with support at both ends. This application requires a spring tension of approximately double the total weight of the cable to maintain 6% sag (3 ft. sag in 50 ft.).

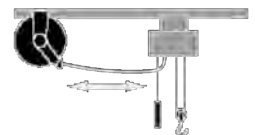

HOW TO ORDER UEA CABLE REELS

1

Contact UEA:

PH: 800.394.9986 or 319.352.3946

FAX: 319.352.2175

www.uea-inc.com

2

Provide us with the following information:

- Model number
- Latching or non-latching
- Wire size
- Number of conductors
- Cable length (in increments of 5')
- Environmental considerations
- Options:
 - Cable - other than type SOW-A supplied on standard reels
 - O.D. of cable to be used if not supplied by UEA
 - Length of stationary cable if other than 5'
 - Custom features

United Equipment Accessories specializes in providing custom electric cable reels. We can fill many requirements for specific cable reels outside the standard reels shown in this literature. We can also provide most reels with spring motors, hand cranks and electric motors.





Check Out Our Blog: UEA Tech Talk
<http://ueatechtalk.com/>

P.O. Box 817 • Waverly, IA 50677-0817
PH: 319.352.3946 • FAX: 319.352.2175
USA 1.800.394.9986 • www.uea-inc.com