

# Ezi-Robo<sup>®</sup>

Actuator series Driven by Ezi-SERVO

- Hollow Rotary Index Table
- Accurate Gear Driven
- High Precision
- High Rigidity
- High Torque
- Easy to Use

**HG**

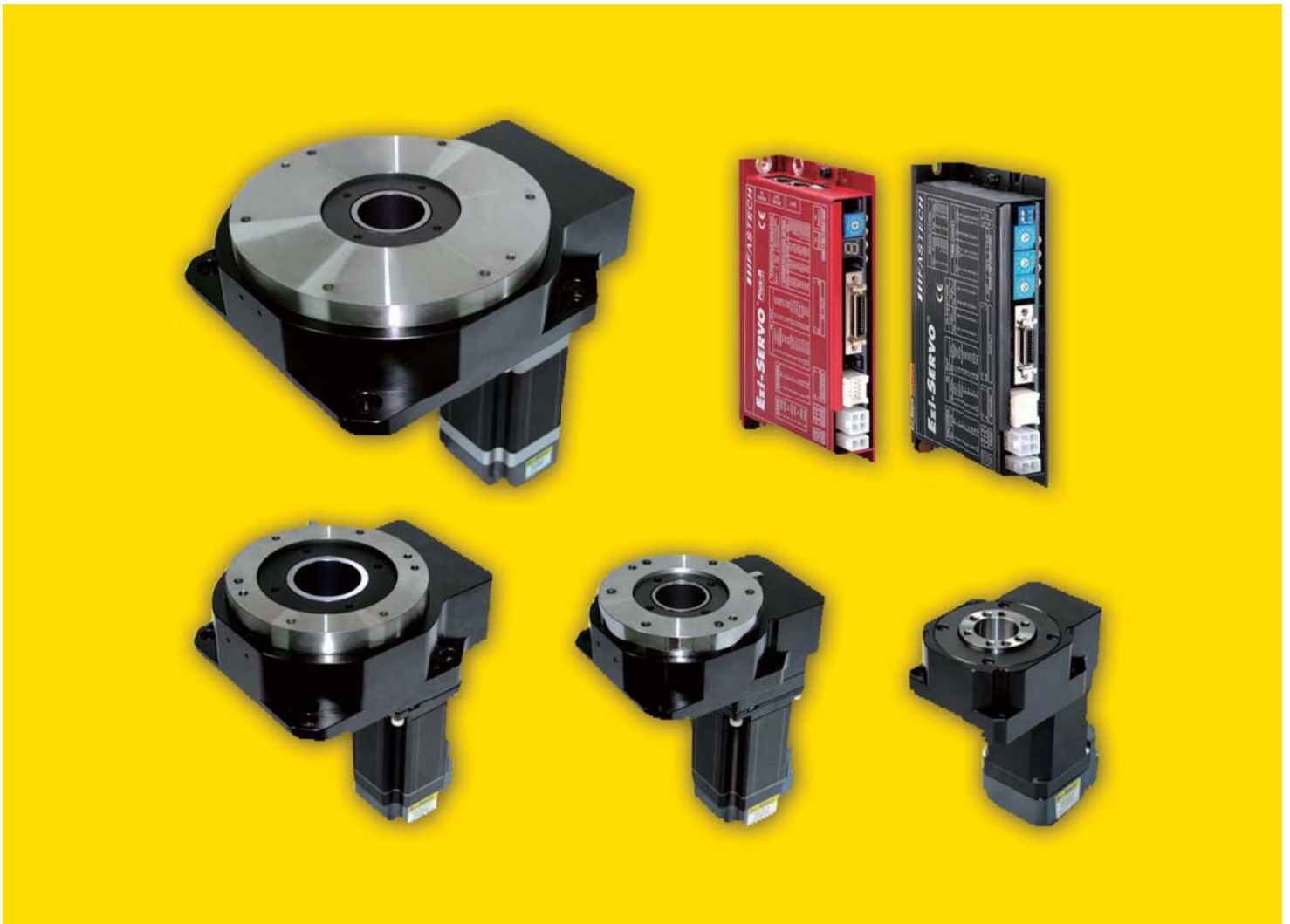

**FASTECH**

*Fast, Accurate, Smooth Motion*

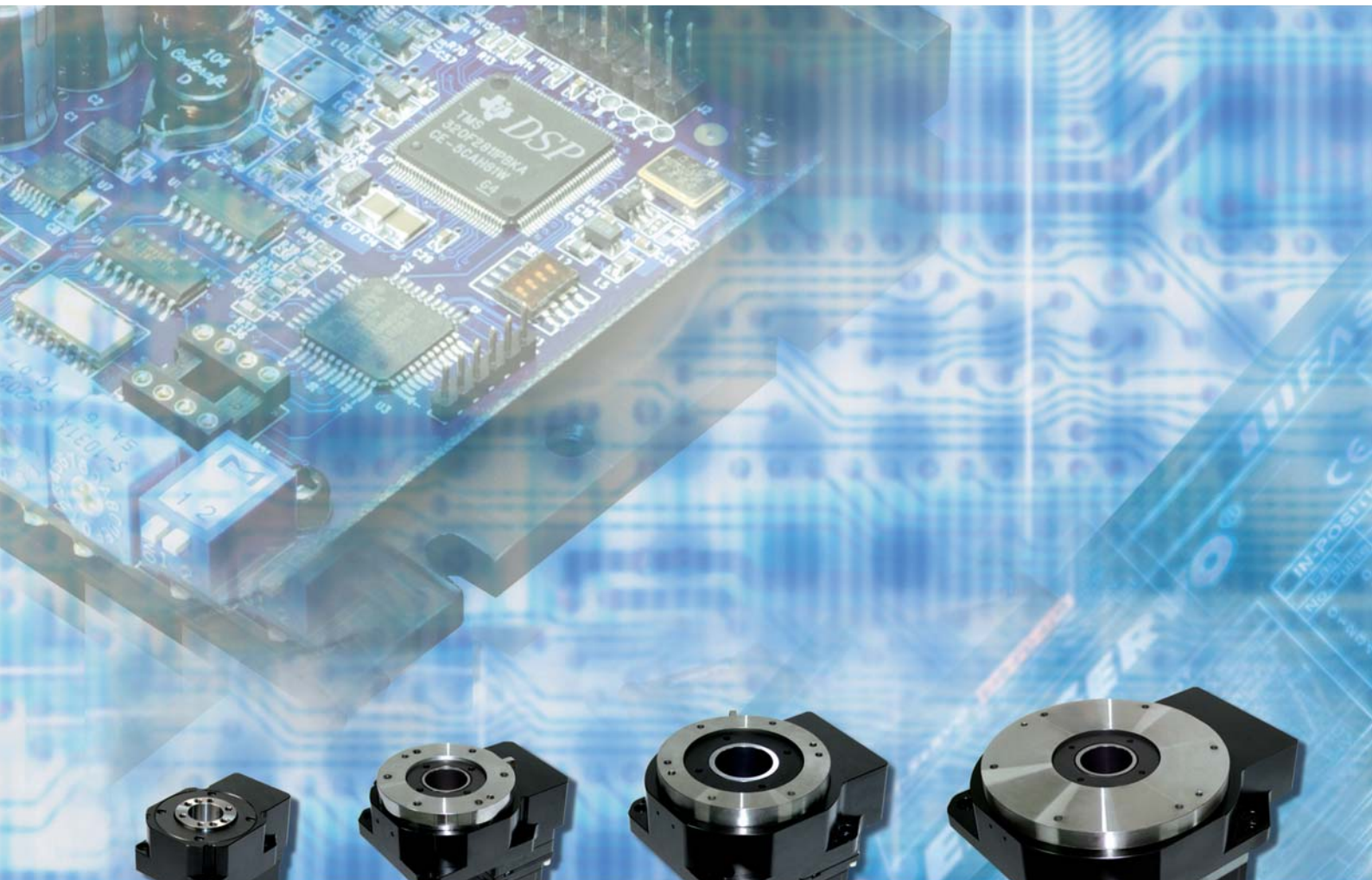

HG60



HG100



HG130

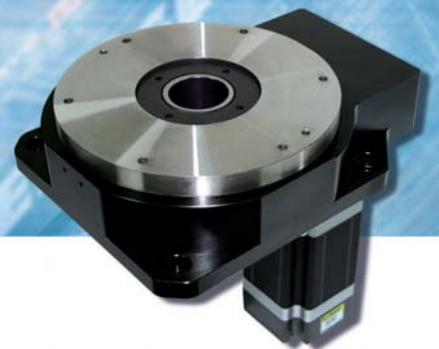

HG200



*Fast, Accurate, Smooth Motion*

## **Ezi-Robo**® **HG**

Actuator series Driven by Ezi-SERVO

High performance of Hollow Rotary Actuator, Ezi-Robo HG Series, is extremely low backlash gear is driven directly into the hollow rotary table combines to high speed, high accuracy of closed loop stepping control system, Ezi-SERVO



**HG275**

**HOLLOW ROTARY TABLE**

Large Diameter hollow bore to penetrate the output table equipped HG Series ensure flexibility and convenience in the design of equipment when install complex wiring and piping.

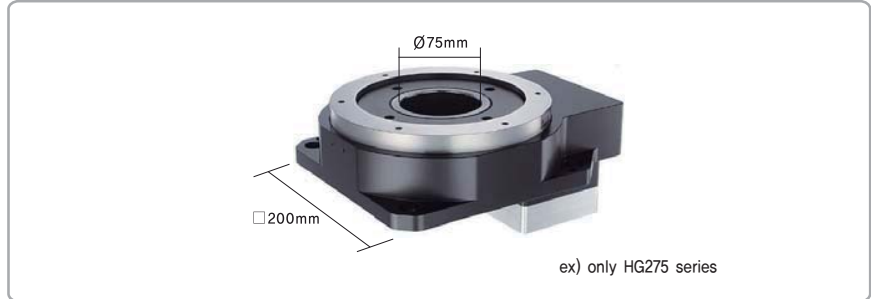

Model Name	Size of plinth (Frame Size)	Hollow Bore Diameter
HG60	60mm	20mm
HG100	100mm	29mm
HG130	130mm	40mm
HG200	200mm	40mm
HG275	200mm	75mm

**ACCURATE GEAR DRIVEN**

Extremely low backlash gear direct drive, so that repetitive positioning accuracy from a single direction is  $\pm 15\text{sec}$ , lost motion by positioning from two directions for less than 2min, and the precise positioning can be determined. And Belt and Pulley are not used in this system so it enables cost saving, unnecessary of maintenance and repair service without adjustment of belt-tensioning

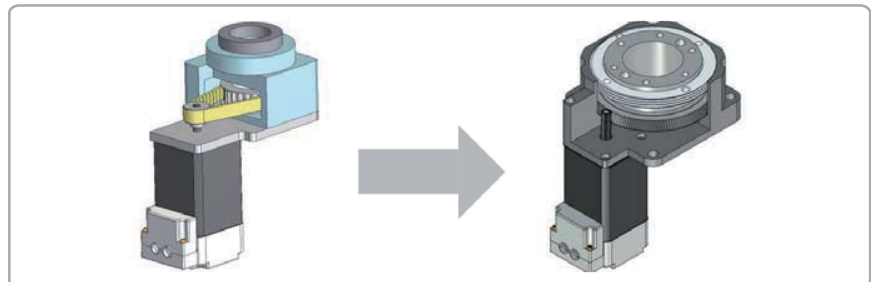

**HIGH RIGIDITY**

High rigidity of taper roller bearing and Ball Bearing integrated HG Series maximizes allowable thrust load and moment load ( But, Deep Groove ball bearings applied in HG60 Series )

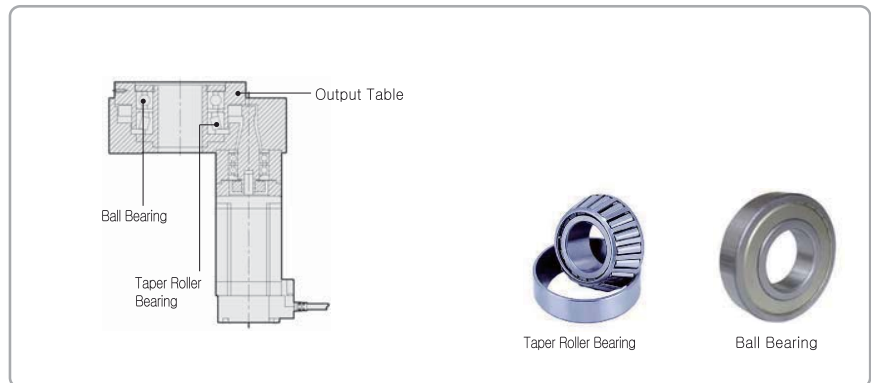



# Feature

## FAST RESPONSE

High rigidity Rotary table fixed to the closed loop stepping control system, Ezi-SERVO can shorten positioning time for big inertia applications.

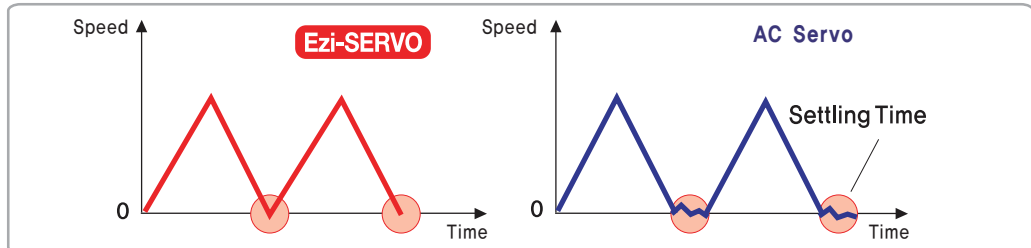

## SUPPORTING SUDDEN LOAD FLUCTUATION AND RAPID ACCELERATION

Adopting a closed loop stepping control system, Ezi-SERVO designed to maintain synchronism and does not have step-out problem, Ezi-Actuator HG series can be driven by rapid acceleration or sudden load fluctuation because the situation in a typical servo system that is prone to fluctuation, Hunting does not occur. For sudden load fluctuation with a servo system is essential to improve the control performance does not need to gain adjustment is gain Tuning Free Actuator.

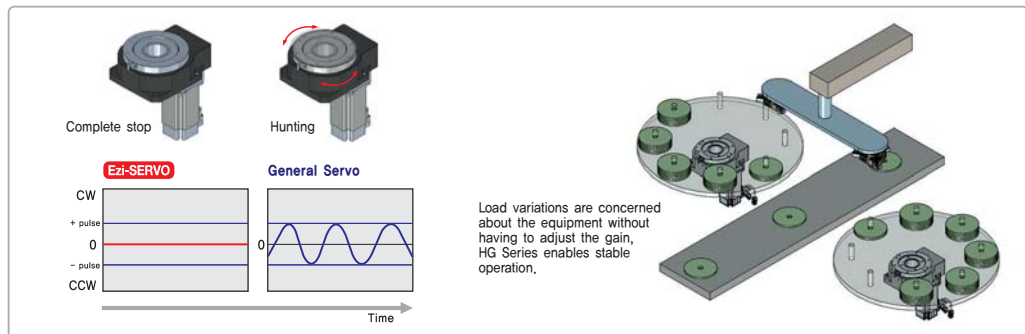

## VARIETY OF CONTROLLER WITH HIGH PERFORMANCE AND MULTI-TASKING

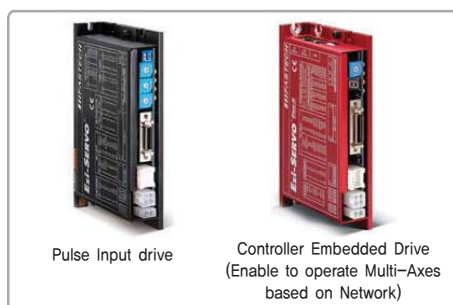

Ezi-SERVO, high performance closed loop stepping control system by adopting, pulse train input drives and controller integrated drives are possible to use.

## NETWORK BASED MOTION CONTROL



A maximum of 16 axis can be operated from a PC through RS-485 communications, All of the Motion conditions are set through the network and saved in Flash ROM as a parameter, Motion Library (DLL) is provided for programming under Windows 2000/XP.

## POSITION TABLE FUNCTION

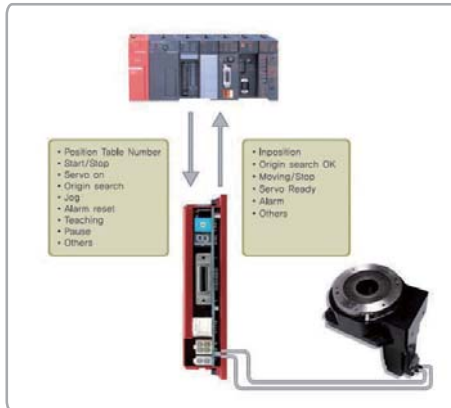

Position Table can be used for motion control by digital input and output signals of host controller. You can operate the motor directly by sending the position table values, start/stop, origin search and other digital input values from a PLC. The PLC can monitor the In-Position, origin search, moving/stop, servo ready and other digital output signals from a drive. A maximum of 256 positioning points can be set from PLC.

## SIMPLE RETURN TO HOME FUNCTION



Rotary table drive from home return often necessary to simplify the return to home operation has been equipped with the optional Home-sensor Set. The sensor set comes with all the parts required for the return to home operation, meaning you will spend less time for designing, assembling and procuring parts related to sensor installation.

## EXTENSIVE INPUT/OUTPUT SIGNALS AND USER-DEFINED FUNCTIONS

Input 9 points / 9 points signal output according to the needs of users can be defined. Therefore, various functions depending on the needs of the user input / output wiring must be used without changing.

### Examples of Ezi-Robo HG Applications

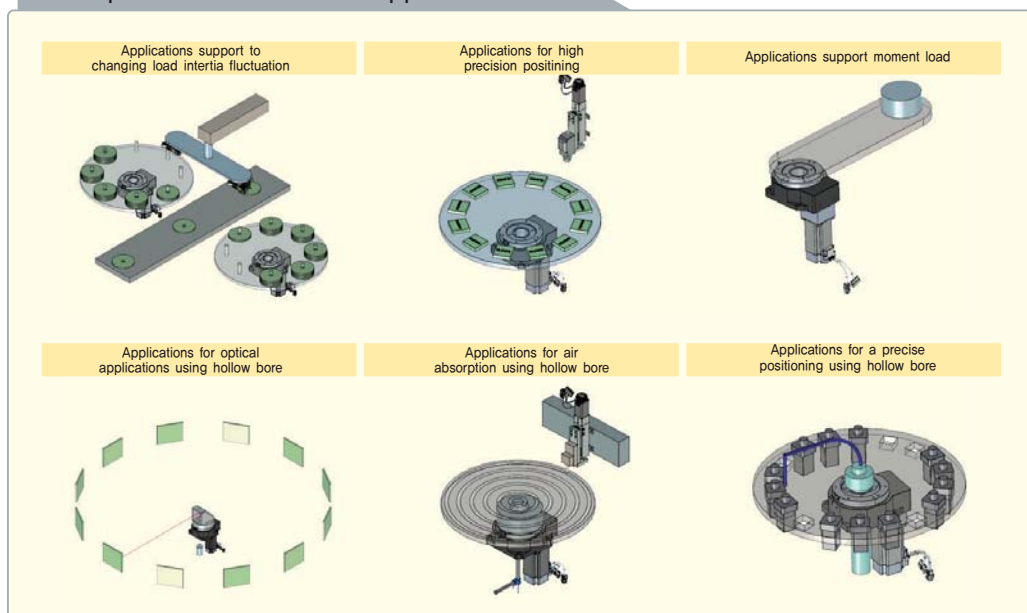

# Number / Specifications and Outline

## Ezi-Robo HG PART NUMBER

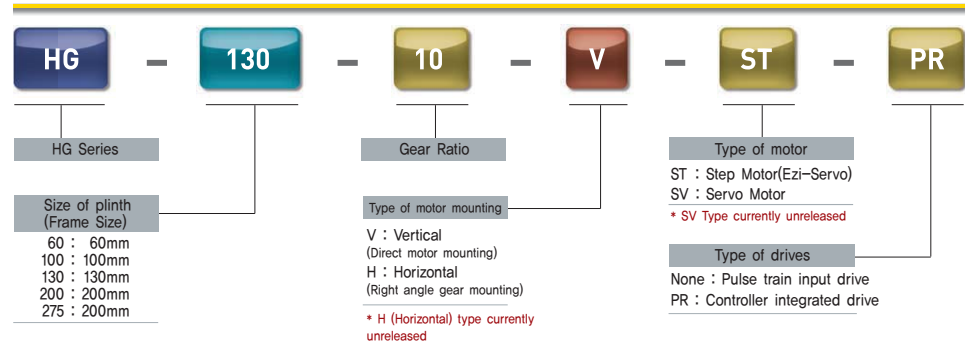

## HOW TO READ THE SPECIFICATION

Part Number	HG60-05-V-ST	Part Number	HG60-05-V-ST
Type of motor	Ezi-Servo42XL Step Motor	Type of motor	Ezi-Servo42XL Step Motor
① Type of output table supporting bearing	Ball Bearing	⑩ Angular transmission error (min)	4 (0.067°)
② Permissible Torque (N · m)	4,5	⑪ Permissible thrust load (N)	100
③ Inertia moment J : (Kg · m2)	2330 X 10 <sup>-7</sup>	⑫ Permissible moment load (N · m)	2
④ Permissible speed (rpm)	300	⑬ Runout of output table surface (mm)	0,01
⑤ Gear ratio	1:5	⑭ Runout of output table inner/outer diameter (mm)	0,01
⑥ Maximum Holding Torque (N · m)	1,6	⑮ Parallelism of output table (mm)	0,005
⑦ Resolution (ppr)	10,000	⑯ Degree of protection IP40 (IP20 for motor connector)	IP40(IP20 for motor Connector)
⑧ Repetitive Positioning Accuracy (sec)	±10 (0,0028°)	⑰ Mass (Kg)	1,2
⑨ Lost Motion (min)	2 (0,033°)		

## Show description of specification items

- ① Type of Output Table Supporting Bearing The type of the bearing used for the output table.
- ② Permissible torque The limit of mechanical strength of the reduction gear mechanism enables to make sure the applied torque including acceleration torque and load fluctuation and it will not exceed the permissible torque.
- ③ Inertia moment Total sum of rotor inertia moment of the motor and the reduction gear of mechanism, converted to a moment on the output table.
- ④ Table Permissible Speed The output table speed can be tolerated by the mechanical strength of the reduction gear mechanism.
- ⑤ Gear ratio Deceleration mechanism to configure the number of teeth of two gears.
- ⑥ Maximum Holding Torque Hollow Rotary actuator can exert the maximum holding torque once the actuator is at standstill with power supplied.
- ⑦ Resolution Needed number of pulse to rotate 1 revolution of output table.
- ⑧ Repetitive Positioning Accuracy A Value indicates the degree of error which is generated when positioning performs repeatedly to the same position in the same direction.
- ⑨ Lost Motion The difference at the stopped angles achieved when the output table is positioned to the same position during forward and reverse direction of motions. And difference is mainly caused by backlash of gear.
- ⑩ Angular transmission error The difference between the theoretical rotation angle of the output table and the actual rotation angle. And this value calculated from the input pulse number.
- ⑪ Permissible thrust load The permissible value of thrust load applied to the output table in the axial direction.
- ⑫ Permissible moment load When a load is applied to a position away from the center of the output table, the output table receives a tilting force and the permissible moment load refers to the permissible value of moment load calculated by multiplying the offset distance from the center by the applied load.
- ⑬ Runout of output table surface The maximum value of runout of the mounted surface of the output table when the output table rotates without load.
- ⑭ Runout of output table inner/outer diameter The maximum value of runout of the inner diameter or outer diameter of the table when the output table rotates without load.
- ⑮ Parallelism of Output Torque Actuator (plinth base) installed on the output side of the Table and value that indicates whether the degree inclines.
- ⑯ Degree of Protection IP40 (IP20 for motor connector) IEC 60529, EN60034-5 (= IEC60034-5) classifies the dust resistance and waterproofing into grades.
- ⑰ Mass A sum of Actuator configured as the output Table, deceleration mechanism, such as driving motor plus the weight of all components.

**HG60 SERIES SPECIFICATIONS**



Part Number	HG60-05-V-ST	HG60-05-V-ST-PR
Type of motor	Ezi-Servo 42XL Step Motor	Ezi-Servo 42XL Step Motor
Type of output table supporting bearing	Ball Bearing	Ball Bearing
Permissible Torque (N · m)	4.5	4.5
Inertia moment J : (Kg · m <sup>2</sup> )	2330 X 10 <sup>-7</sup>	2330 X 10 <sup>-7</sup>
Permissible speed (rpm)	300	300
Gear ratio	1:5	1:5
Maximum Holding Torque (N · m)	1.6	1.6
Resolution (ppr)	10,000	10,000
Repetitive Positioning Accuracy (sec)	±10 (0.0028°)	±10 (0.0028°)
Lost Motion (min)	2 (0.033°)	2 (0.033°)
Angular transmission error (min)	4 (0.067°)	4 (0.067°)
Permissible thrust load (N)	100	100
Permissible moment load (N · m)	2	2
Runout of output table surface (mm)	0,015	0,015
Runout of output table inner/outer diameter (mm)	0,015	0,015
Parallelism of output table (mm)	0,03	0,03
Degree of protection IP40 (IP20 for motor connector)	IP40(IP20 for motor Connector)	IP40(IP20 for motor Connector)
Mass (Kg)	1,0	1,0

**HG60 ROTATIONAL SPEED TORQUE CHARACTERISTIC**

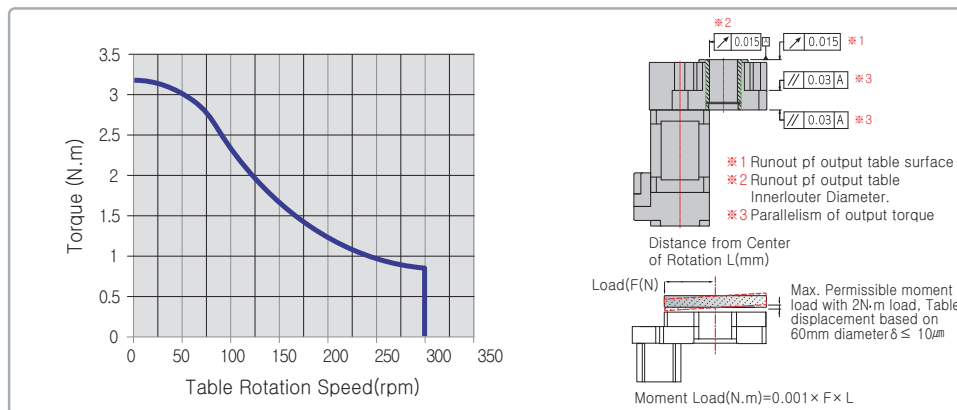

**HG60 SERIES DIMENSIONS**

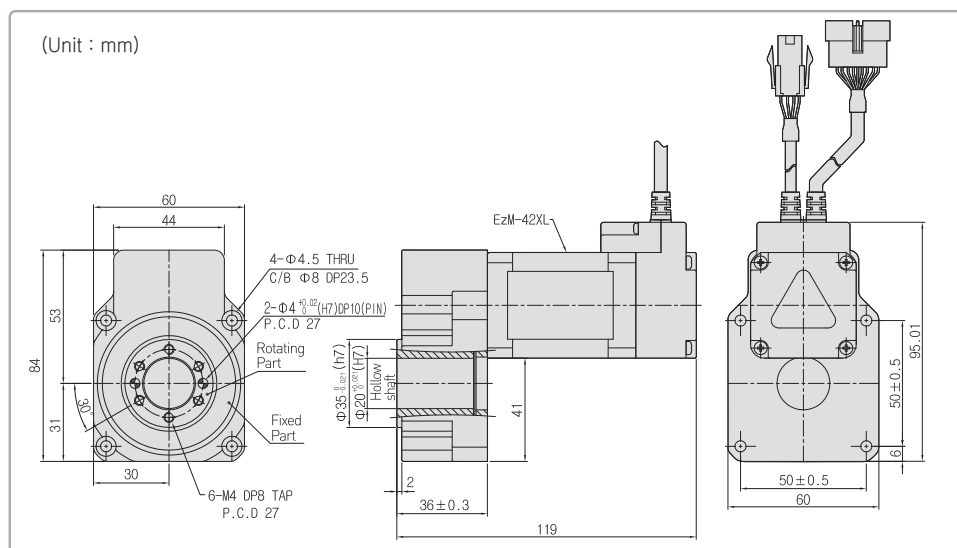

# Specifications and Outline

## HG100 SERIES SPECIFICATIONS



Part Number	HG100-08-V-ST	HG100-08-V-ST-PR
Type of motor	Ezi-Servo 60L Step Motor	Ezi-Servo 60L Step Motor
Type of output table supporting bearing	Taper Roller Bearing + Ball Bearing	Taper Roller Bearing + Ball Bearing
Permissible Torque (N · m)	12	12
Inertia moment J : (Kg · m <sup>2</sup> )	3898 X 10 <sup>-6</sup>	3898 X 10 <sup>-6</sup>
Permissible speed (rpm)	200	200
Gear ratio	1:8	1:8
Maximum Holding Torque (N · m)	10	10
Resolution (ppr)	10,000	10,000
Repetitive Positioning Accuracy (sec)	±10 (0.0028°)	±10 (0.0028°)
Lost Motion (min)	2 (0.033°)	2 (0.033°)
Angular transmission error (min)	4 (0.067°)	4 (0.067°)
Permissible thrust load (N)	500	500
Permissible moment load (N · m)	10	10
Runout of output table surface (mm)	0.01	0.01
Runout of output table inner/outer diameter (mm)	0.01	0.01
Parallelism of output table (mm)	0.01	0.01
Degree of protection IP40 (IP20 for motor connector)	IP40(IP20 for motor Connector)	IP40(IP20 for motor Connector)
Mass (Kg)	4.0	4.0

## HG100 ROTATIONAL SPEED TORQUE CHARACTERISTIC

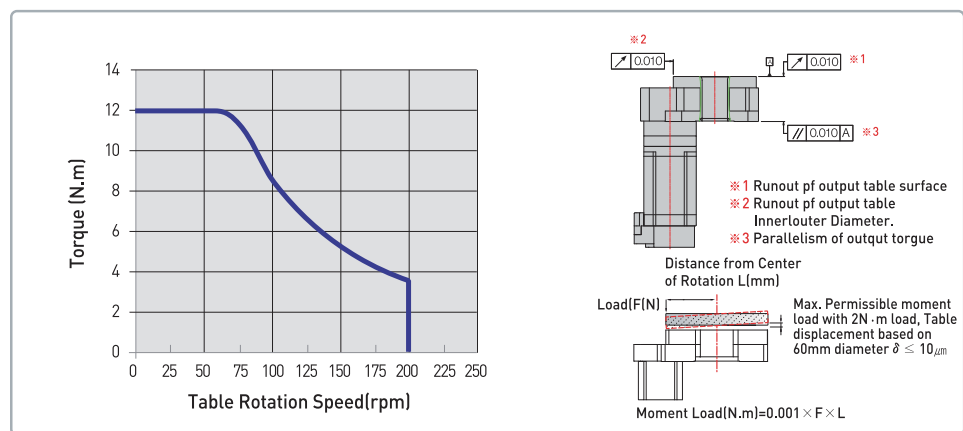

## HG100 SERIES DIMENSIONS

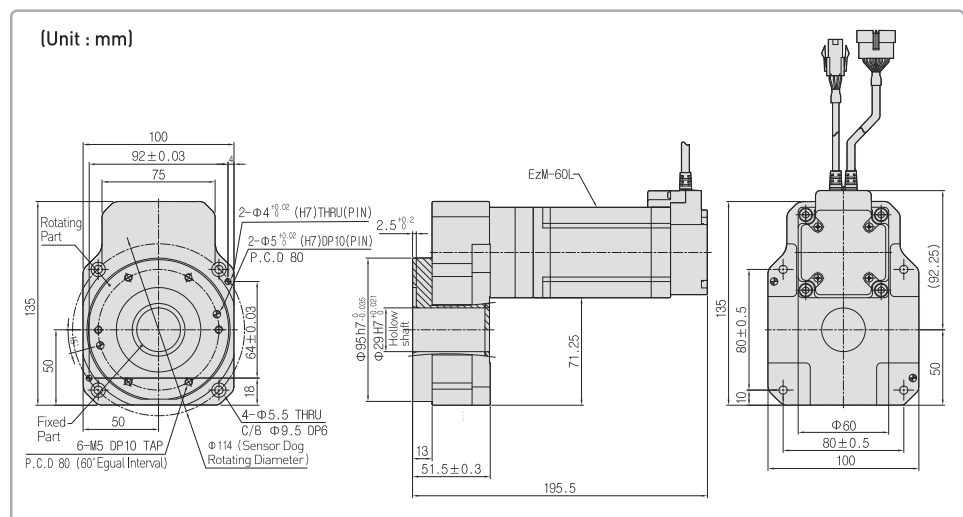



**HG130 SERIES SPECIFICATIONS**



Part Number	HG130-10-V-ST	HG130-10-V-ST-PR
Type of motor	Ezi-Servo 60L Step Motor	Ezi-Servo 60L Step Motor
Type of output table supporting bearing	Taper Roller Bearing + Ball Bearing	Taper Roller Bearing + Ball Bearing
Permissible Torque (N · m)	14	14
Inertia moment J : (Kg · m <sup>2</sup> )	9216 X 10 <sup>-6</sup>	9216 X 10 <sup>-6</sup>
Permissible speed (rpm)	200	200
Gear ratio	1:10	1:10
Maximum Holding Torque (N · m)	12.5	12.5
Resolution (ppr)	10,000	10,000
Repetitive Positioning Accuracy (sec)	±10 (0.0028°)	±10 (0.0028°)
Lost Motion (min)	2 (0.033°)	2 (0.033°)
Angular transmission error (min)	3 (0.05°)	3 (0.05°)
Permissible thrust load (N)	2000	2000
Permissible moment load (N · m)	20	20
Runout of output table surface (mm)	0.01	0.01
Runout of output table inner/outer diameter (mm)	0.01	0.01
Parallelism of output table (mm)	0.01	0.01
Degree of protection IP40 (IP20 for motor connector)	IP40(IP20 for motor Connector)	IP40(IP20 for motor Connector)
Mass (Kg)	6.1	6.1

**HG130 ROTATIONAL SPEED TORQUE CHARACTERISTIC**

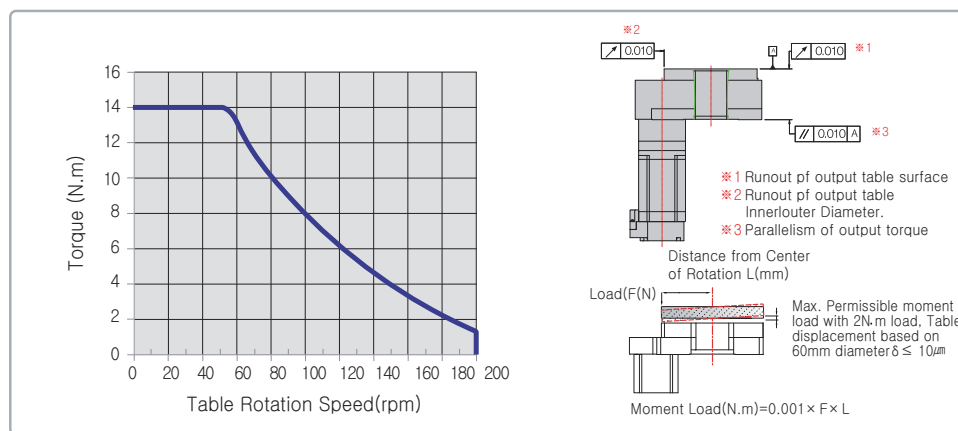

**HG130 SERIES DIMENSIONS**

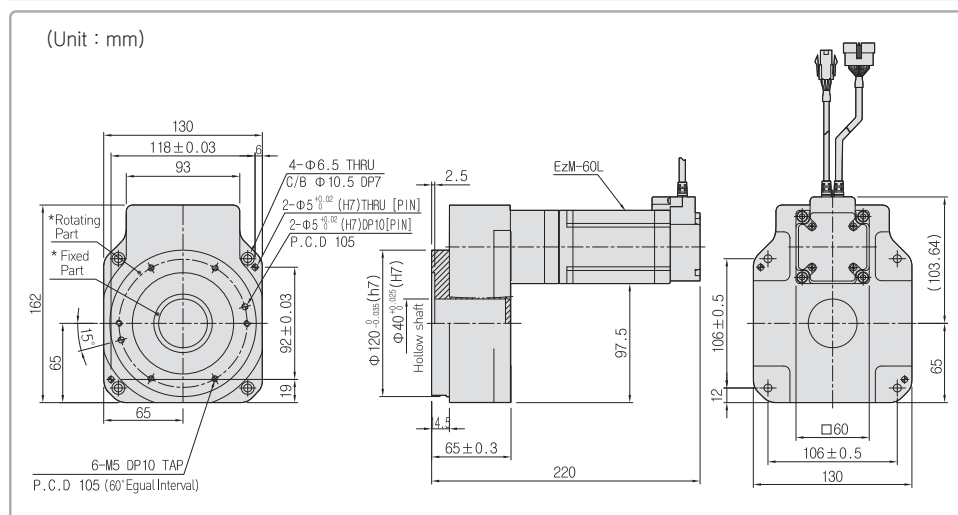

# Specifications and Outline

## HG200 SERIES SPECIFICATIONS

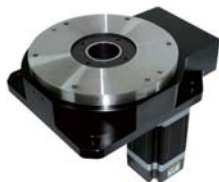

Part Number		HG200-10-V-ST	HG200-10-V-ST-PR
Type of motor	-	Ezi-Servo 86L Step Motor	Ezi-Servo 86L Step Motor
Type of output table supporting bearing		Taper Roller Bearing + Ball Bearing	Taper Roller Bearing + Ball Bearing
Permissible Torque	(N · m)	50	50
Inertia moment	J : (Kg · m <sup>2</sup> )	85792 X 10 <sup>-6</sup>	85792 X 10 <sup>-6</sup>
Permissible speed	(rpm)	110	110
Gear ratio		1:10	1:10
Maximum Holding Torque	(N · m)	43	43
Resolution	(ppr)	10,000	10,000
Repetitive Positioning Accuracy	(sec)	±10 (0.0028°)	±10 (0.0028°)
Lost Motion	(min)	2 (0.033°)	2 (0.033°)
Angular transmission error	(min)	2 (0.033°)	2 (0.033°)
Permissible thrust load	(N)	4000	4000
Permissible moment load	(N · m)	100	100
Runout of output table surface	(mm)	0.01	0.01
Runout of output table inner/outer diameter	(mm)	0.015	0.015
Parallelism of output table	(mm)	0.01	0.01
Degree of protection IP40 (IP20 for motor connector)		IP40(IP20 for motor Connector)	IP40(IP20 for motor Connector)
Mass	(Kg)	15.5	15.5

## HG200 ROTATIONAL SPEED TORQUE CHARACTERISTIC

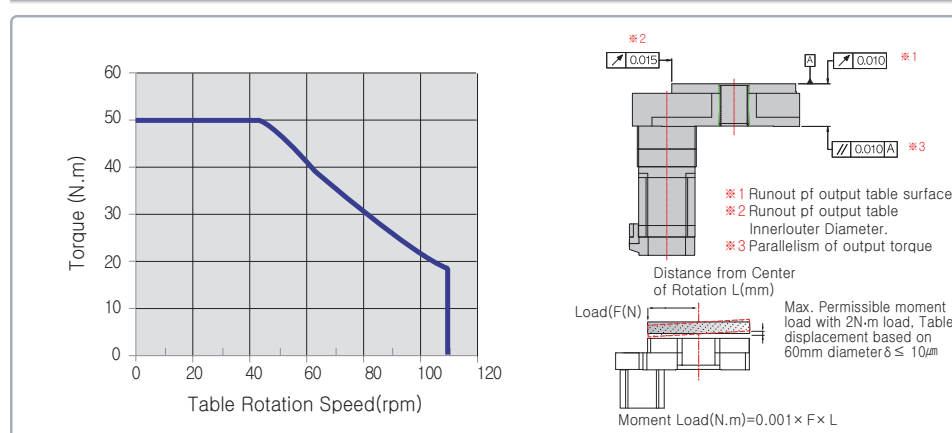

## HG200 SERIES DIMENSIONS

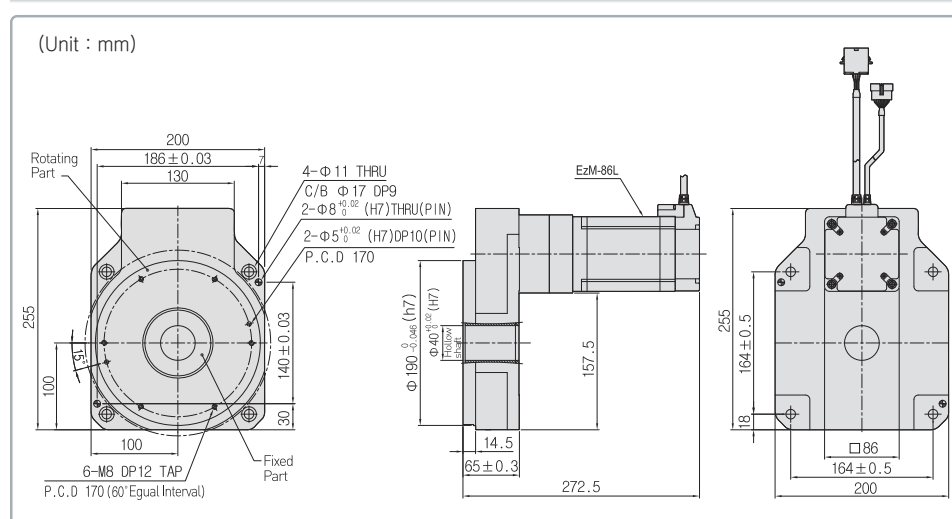

 HG275 SERIES SPECIFICATIONS



Part Number		HG200-10-V-ST	HG200-10-V-ST-PR
Type of motor	-	Ezi-Servo 86L Step Motor	Ezi-Servo 86L Step Motor
Type of output table supporting bearing		Taper Roller Bearing + Ball Bearing	Taper Roller Bearing + Ball Bearing
Permissible Torque	(N · m)	55	55
Inertia moment	J : (Kg · m <sup>2</sup> )	111279 X 10 <sup>-6</sup>	111279 X 10 <sup>-6</sup>
Permissible speed	(rpm)	110	110
Gear ratio		1:10	1:10
Maximum Holding Torque	(N · m)	43	43
Resolution	(ppr)	10,000	10,000
Repetitive Positioning Accuracy	(sec)	±10 (0.0028°)	±10 (0.0028°)
Lost Motion	(min)	2 (0.033°)	2 (0.033°)
Angular transmission error	(min)	2 (0.033°)	2 (0.033°)
Permissible thrust load	(N)	4000	4000
Permissible moment load	(N · m)	100	100
Runout of output table surface	(mm)	0.01	0.01
Runout of output table inner/outer diameter	(mm)	0.015	0.015
Parallelism of output table	(mm)	0.01	0.01
Degree of protection IP40 (IP20 for motor connector)		IP40(IP20 for motor Connector)	IP40(IP20 for motor Connector)
Mass	(Kg)	19.7	19.7

 HG275 ROTATIONAL SPEED TORQUE CHARACTERISTIC

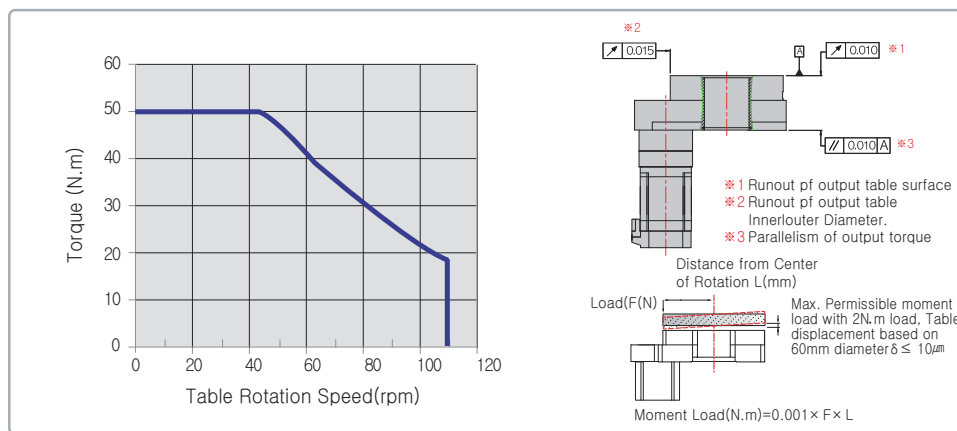

 HG275 SERIES DIMENSIONS

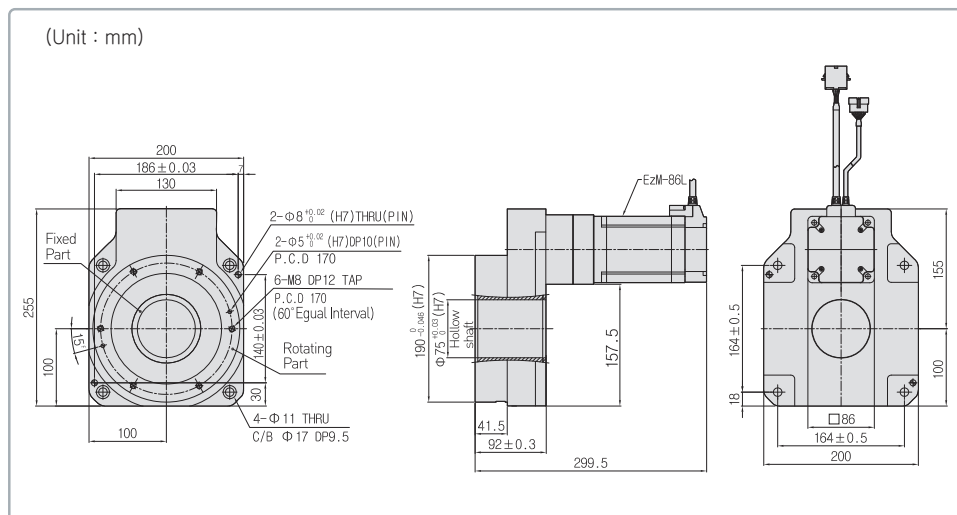

# Mechanism Option

## HOME-SENSOR SET

Rotary table drive less frequently required to perform homing Photo Micro Sensor, Connector Attach Cable, blue filter, install the screws to Set Sensor Set the origin has been established as an option. There needed to detect the origin because the origin of all parts of the installation when necessary Sensor takes part in designing manufacturing and parts procurement to relieve the trouble, it also can be used to install easily

### ■ Type

Madel	Sensor output	Applicable product
OSHG-A	NPN	HG60, HG100
OSHG-AY	PNP	
OSHG-B	NPN	HG130, HG200, HG275
OSHG-BY	PNP	

※Special Instructions to assemble sensor  
Please use provided bolt and washer  
Do not use more than M3x6 bolt. It may cause product damage

### ■ Home-Sensor Set Composition OSHG-A



### ■ Specifications

Type	NPN Type	PNP Type
Sensor Madel	EE-SX672A(OMRON Product) HG60, HG100, HG130, HG200, HG275 common	EE-SX672R(OMRON Product) HG60, HG100, HG130, HG200, HG275 common
Input Voltage	DC5~24V±10% Ripple (P-P) 10% less	DC5~24V±10% Ripple (P-P) 10% less
Current Consumption	35mA less	30mA less
Control Output	NPN Open Collector output DC5~24V 100mA less Residual Voltage 0.8V less (at load current of 100mA)	PNP Open Collector output DC5~24V 100mA less Residual Voltage 1.3V less (at load current of 100mA)
Display LED	Detection (Red)	Detection (Red)
Sensor Logic	Normally Open/Normally Closed (Switchable, depending on connection)	Normally Open/Normally Closed (Switchable, depending on connection)

### ■ Connector Attached Cable (OMRON robot ode attached connector EE1010-R)



#### Terminal Layout

①	⊕	Brown
②	L	Pink
③	OUT	Black
④	⊖	Blue

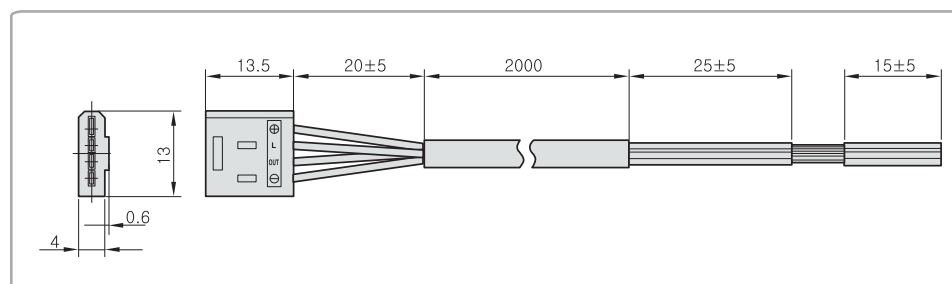

### ■ Notes for sensor set of installation

- Option to install is the origin sensor set pay attention to the following.
- Use the temperature below 40°C, Motor Part surface temperature 90°C or less, to be sure to set operating conditions
  - Please prepare individual sensor and Bracket to get homing with using from motor shaft. Notes for sensor lines is extended, Sensor shield should be cabled and grounded if extended to more than 2 Meter long.

### ■ Notes for sensor lines is extended

- Sensor shield should be cabled and grounded if extended to more than 2 Meter long.

 DIMENSIONS OF HOME-SENSOR INSTALLATION

■ HG60

(Unit : mm)

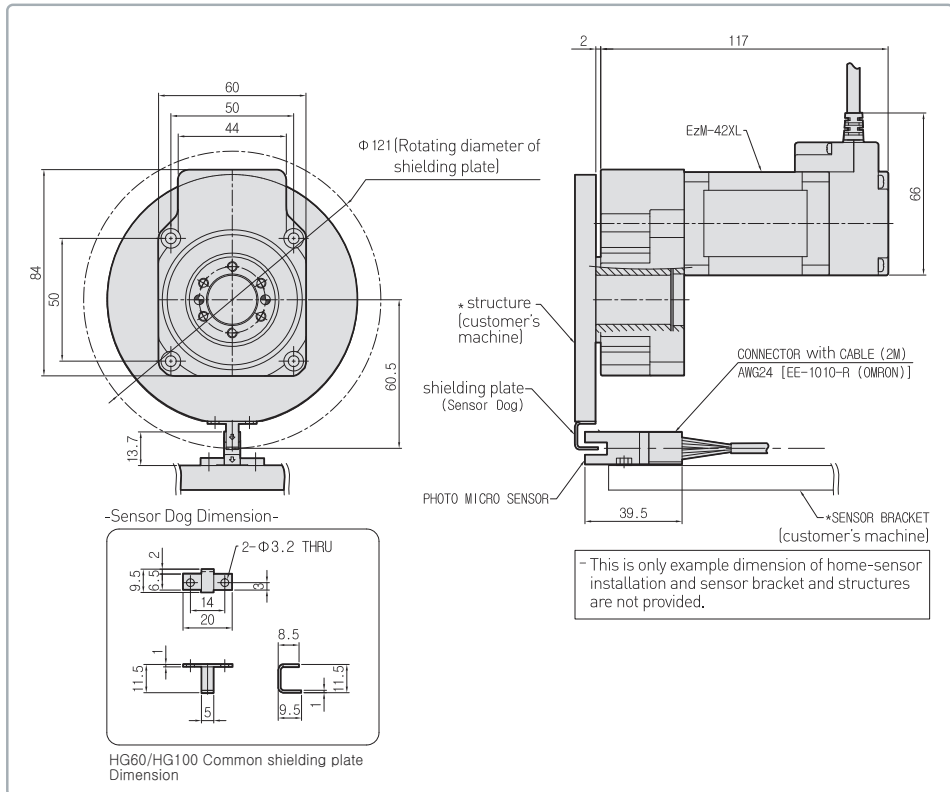

■ HG100

(Unit : mm)

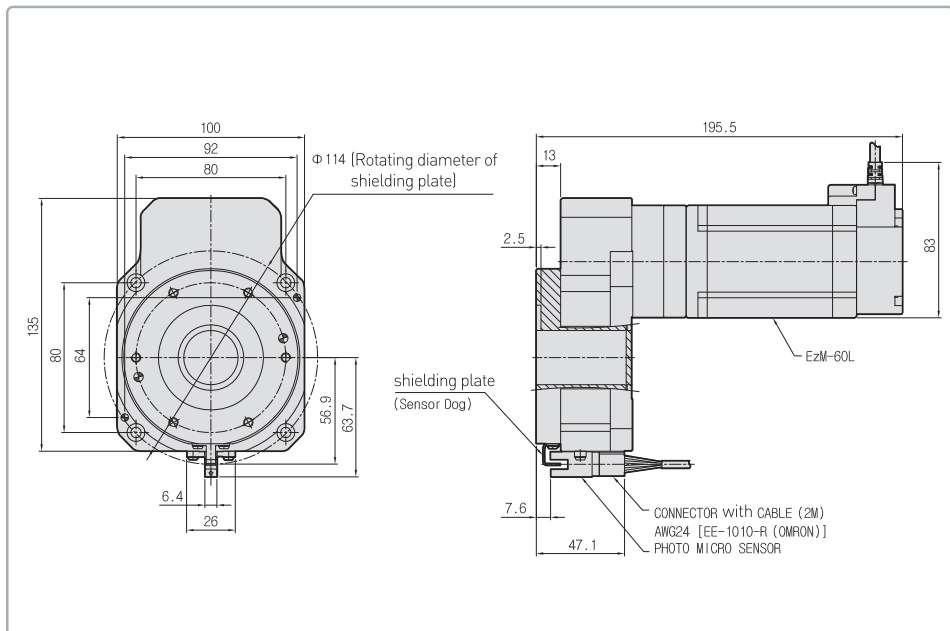



# Mechanism Option

## ☑ DIMENSIONS OF HOME-SENSOR INSTALLATION

### ■ HG130

(Unit : mm)

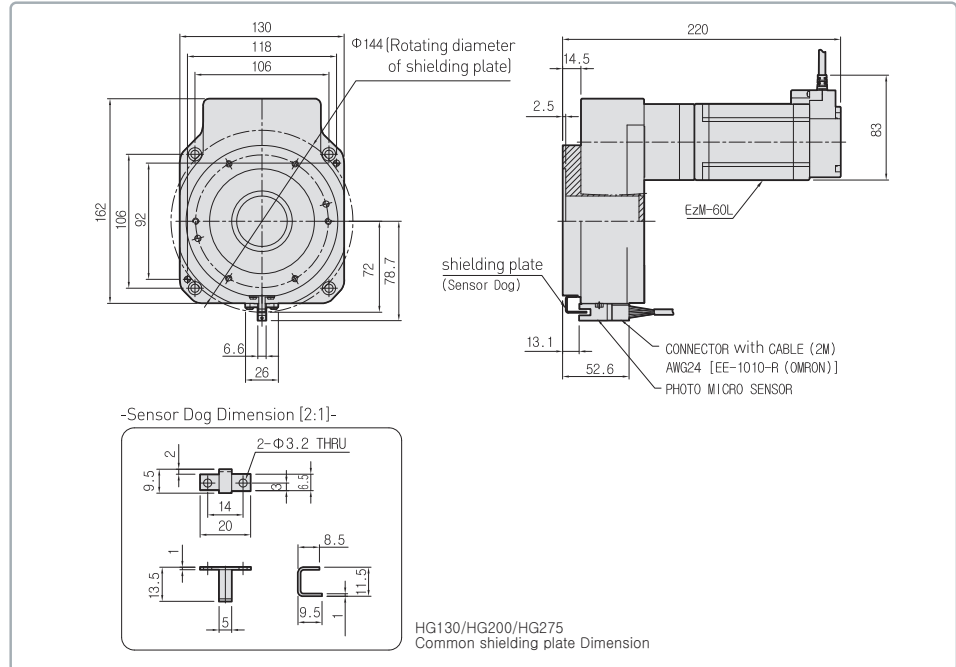

### ■ HG200

(Unit : mm)

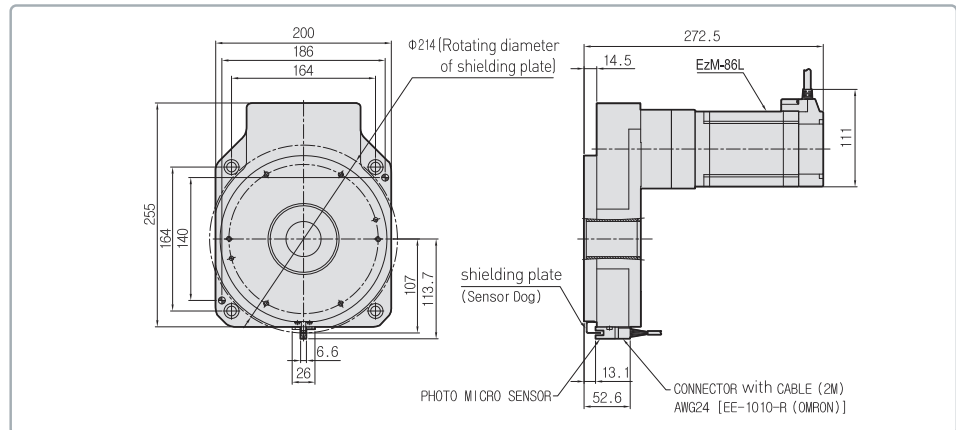

### ■ HG275

(Unit : mm)

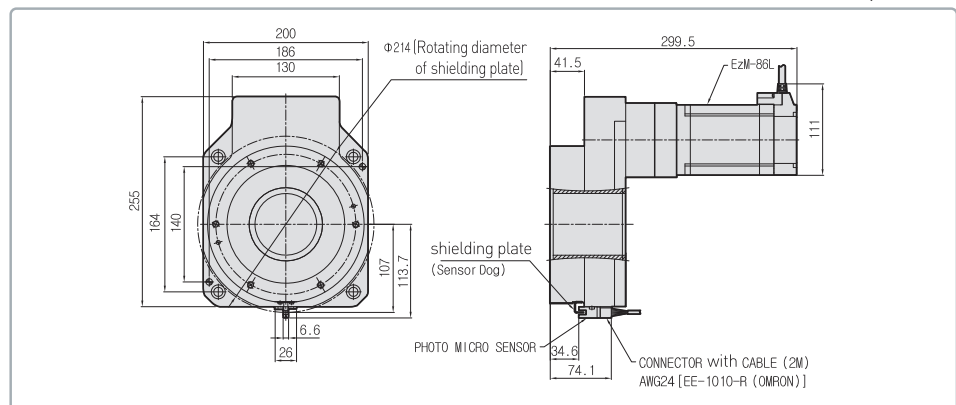

**DIMENSIONS OF HOME-SENSOR INSTALLATION**

■ NPN Type

Please use DC 5V, DC 24V power supply or less and consult the current value less than 100mA. If more than 100mA, please connect external register R. And sensor power supply and user controller power supply GND should be a common.

■ Pulse train input unit

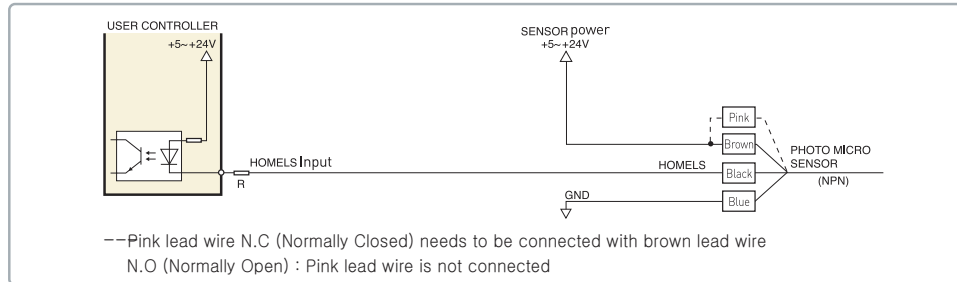

■ Controller integrated unit

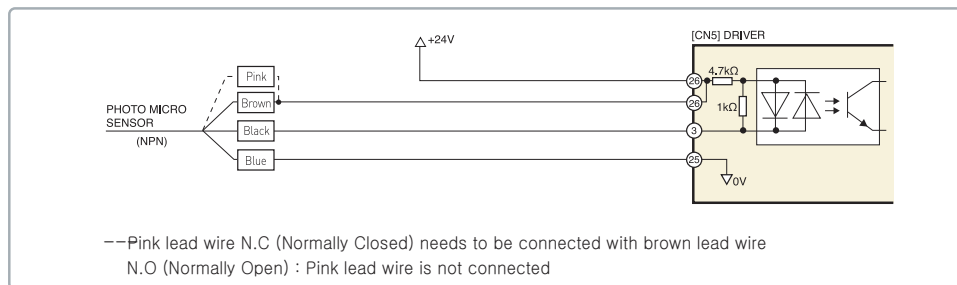

■ PNP Type

Please use DC 5V, DC power supply or less and consult the current value less than 100mA. If more than 50mA, please connect external register R.

■ Pulse train input unit

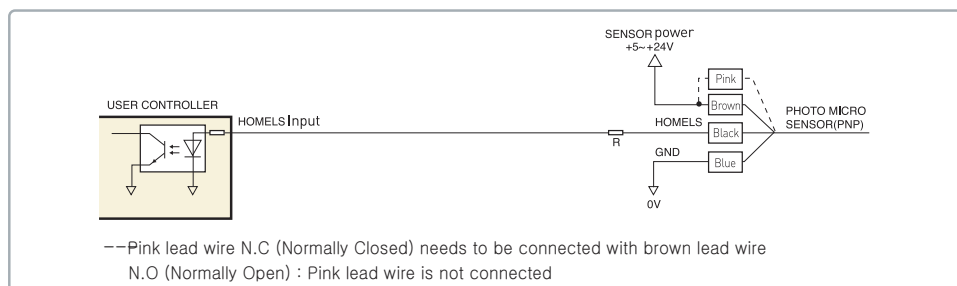

■ Controller integrated unit

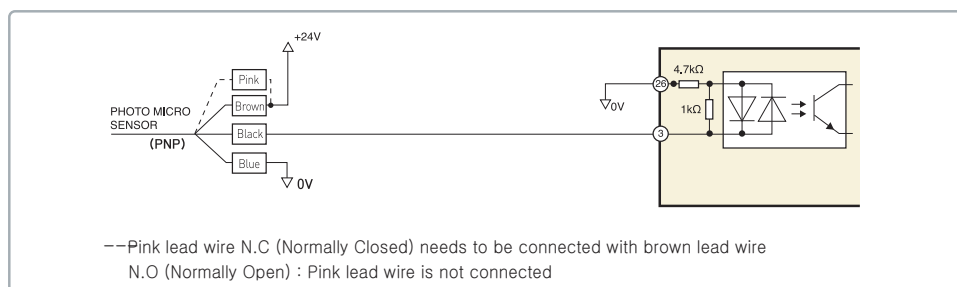

# Drive and Motor Combination

## PULSE INPUT DRIVE AND MOTOR COMBINATION

Unit Model Number	Motor Model Number	Drive Model Number
HG60-05-V-ST	EzM-42XL-A	EzS-PD-42XL-A
HG100-08-V-ST	EzM-60L-A	EzS-PD-60L-A
HG130-10-V-ST	EzM-60L-A	EzS-PD-60L-A
HG200-10-V-ST	EzM-86L-A	EzS-PD-86L-A
HG275-10-V-ST	EzM-86L-A	EzS-PD-86L-A



## CONTROLLER EMBEDDED DRIVE AND MOTOR COMBINATION

Unit Model Number	Motor Model Number	Drive Model Number
HG60-05-V-ST-PR	EzM-42XL-A	EzS-NDR-42XL-A
HG100-08-V-ST-PR	EzM-60L-A	EzS-NDR-60L-A
HG130-10-V-ST-PR	EzM-60L-A	EzS-NDR-60L-A
HG200-10-V-ST-PR	EzM-86L-A	EzS-NDR-86L-A
HG275-10-V-ST-PR	EzM-86L-A	EzS-NDR-86L-A



# Pulse Input Drive

## SPECIFICATIONS OF PULSE INPUT DRIVE

Motor Model	EzM-42 series	EzM-56 series	EzM-60 series
Driver Model	EzS-PD-42 series	EzS-PD-56 series	EzS-PD-60 series
Input Voltage	24VDC±10%		
Control Method	Closed loop control with 32bit DSP		
Current Consumption	Max 500mA (Except motor current)		
Operating Condition	Ambient Temperature	In Use : 0~55℃ In Storage : -20~70℃	
	Humidity	In Use : 35~85% (Non-condensing) In Storage : 10~90% (Non-condensing)	
	Vib,Resist.	0,5G	
Function	Rotation Speed	0~3000rpm	
	Resolution(P/R)	10,000/Rev. Encoder model : 500, 1000, 1600, 2000, 3600, 5000, 6400, 7200, 10000	
	Max.Input Pulse Frequency	500KHz (Duty 50%)	
	Protection Functions	Over current, Over speed, Step out, Over load, Over temperature, Over regenerated voltage, Motor connect error, Encoder connect error, Low input voltage, Inposition error, System error, ROM error, High input voltage	
	LED Display	Power status, Alarm status, In-Position status, Servo On status	
	In-Position Selection	0~F(Selectable with rotary switch)	
	Position Gain Selection	0~F(Selectable with rotary switch)	
	Pulse Input Method	1-Pulse /2-Pulse (Selectable with DIP switch)	
	Rotational Direction	CW / CCW ((Selectable with DIP switch)	
Speed/Position Control Command	Pulse train input		
I/O Signals	Input Signals	Position command pulse,Servo On/Off,Alarm reset (Photocoupler input)	
	Output Signals	In-Position,Alarm (Photocoupler output) Encoder signal(A+,A-,B+,B-,Z+,Z-,26C31 of Equivalent),(Line Driver output)	

## DIMENSION OF PULSE INPUT DRIVE(mm)

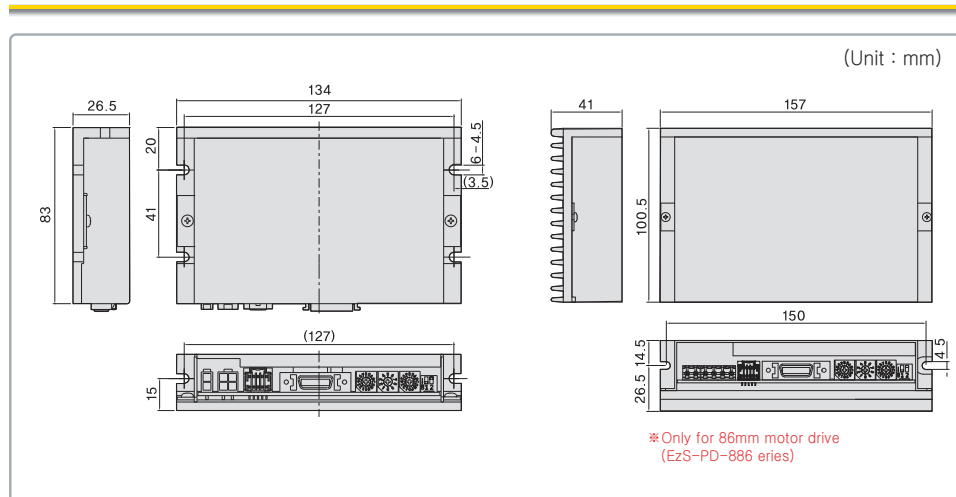

# Controller Embedded Drive

## ☑ SPECIFICATIONS OF CONTROLLER EMBEDDED DRIVE

Motor Model	EzM-42 series	EzM-60 series	EzM-86 series
Driver Model	EzS-NDR-42 series	EzS-NDR-60 series	EzS-NDR-86 series
Input Voltage	24VDC±10%	24VDC±10%	40~70UDC
Control Method	Closed Loop Control with 32bit DSP		
Multi Axes Drive	Maximum 16 axes through Daisy-Chain		
Position Table	256 motion command steps (Continuous,Wait,Loop,Jump and External start etc.)		
Current Consumption	Max 500mA (Except motor current)		
Operating Condition	Ambient Temperature	In Use : 0~55℃ In Storage : -20~70℃	
	Humidity	In Use : 35~85% In Storage : 10~90%	
	Vib.Resist.	0.5G	
Function	Rotation Speed	0~3,000rpm	
	Resolution(P/R)	10,000/Rev. Encoder model : 500 1,000 1,600 2,000 3,600 5,000 6,400 7,200 10,000	
	Protection Functions	Over current, Over speed, Position tracking error, Over load, Over temperature, Over regenerated voltage, Motor connect error, Encoder connect error, Motor voltage error, In-Position error, System error, ROM error, Input voltage error, Position overflow error	
	LED Display	Power status, Alarm status, In-Position status, Servo On status	
	In-Position Selection	0~F(Selectable by parameter)	
	Position Gain Selection	0~F(Selectable by parameter)	
	Rotational Direction	CW / CCW (Selectable by parameter)	
I/O Signals	Input Signals	3 dedicated input (LIMIT+, LIMIT-, ORIGIN), 9 programmable input (Photocoupler)	
	Output Signal	1 dedicated output (Compare Out), 9 programmable output (Photocoupler), Brake signal	
Communication Interface	The RS-485 serial communication with PC Transmission speed :9,600~921,600bps		
Position Control	Incremental mode /Absolute mode Data Range : -134,217,727 to +134,217,727pulse, Operating speed : Max. 500rpm		

## ☑ DIMENSION OF CONTROLLER EMBEDDED DRIVE(mm)

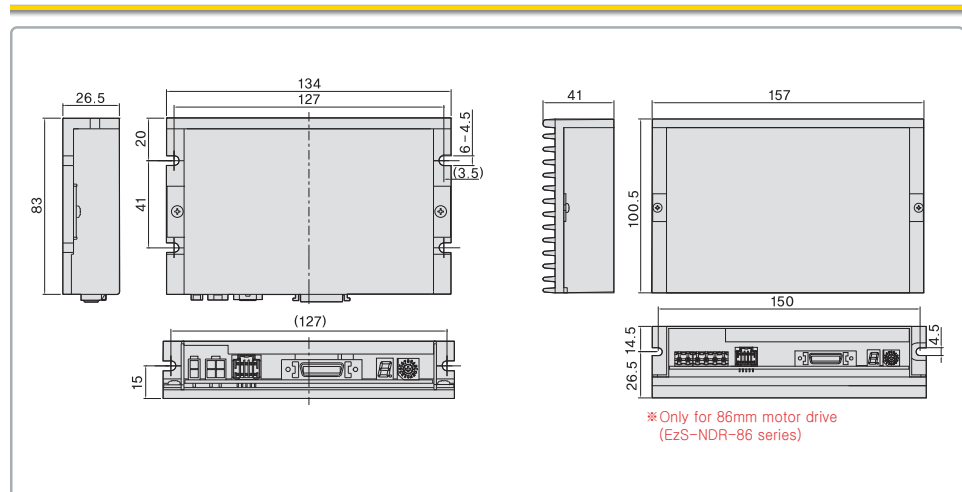



# Motor Specifications and Torque Characteristics

## SPECIFICATIONS OF MOTOR(SAME FOR PULSE INPUT AND CONTROLLER EMBEDDED DRIVE)

Model	Unit	EzM-42XL-A	EzM-60L-A	EzM-86L-A
Drive Method	-	BI-POLAR	BI-POLAR	BI-POLAR
Number of Phase	-	2	2	2
Voltage	VDC	7.2	2.6	3.6
Current per Phase	A	1.2	4	6
Resistance per Phase	Ohm	6	0.65	0.6
Inductance per Phase	mH	15.6	2.4	6.5
Holding Torque	N · m	0.8	2.4	8.5
Rotor Inertia	g · cm	114	800	2700
Weight	g	500	1600	3900
Length	mm	59	90	117
Allowable Thrust Load	N	Lower than motor weight		
Insulation Resistance	Mohm	100min, (at 500VDC)		
Insulation Class	-	CLASS B		
Operating Temperature	°C	0 to 55		

## MOTOR TORQUE CHARACTERISTICS(SAME FOR PULSE INPUT AND CONTROLLER EMBEDDED DRIVE)

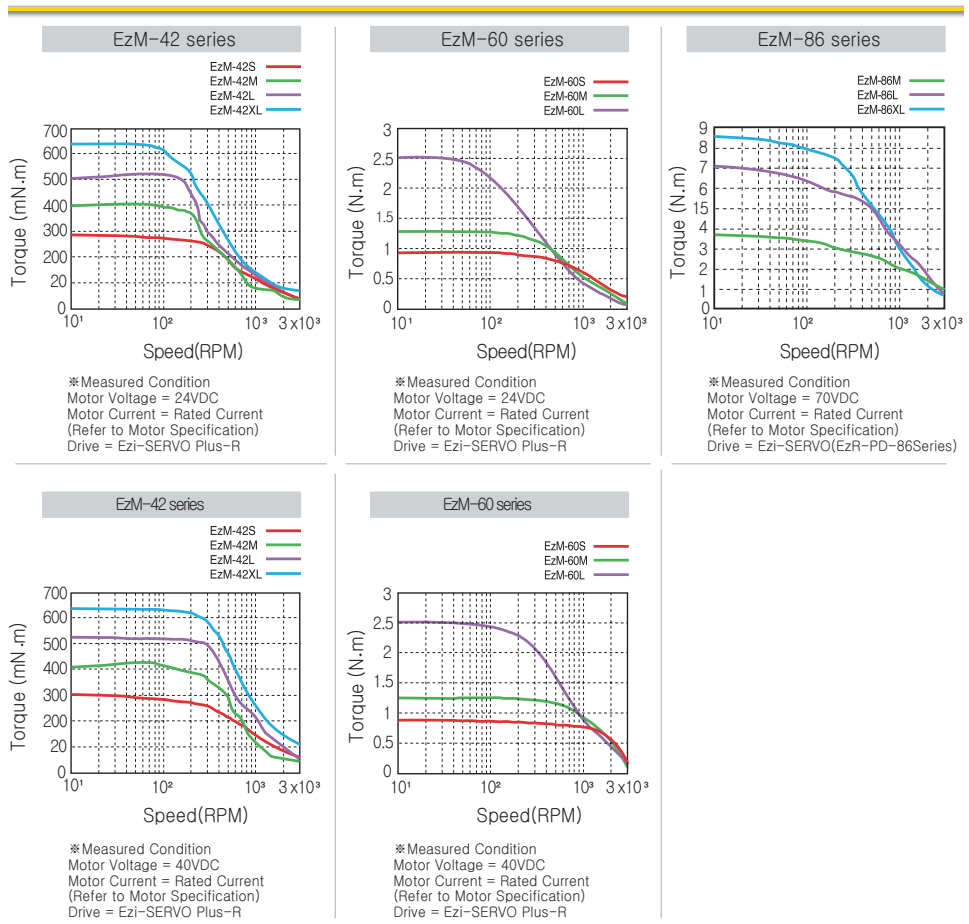

# Pulse Input Drive Setting and Operating

## PULSE INPUT DRIVE SETTING AND OPERATING

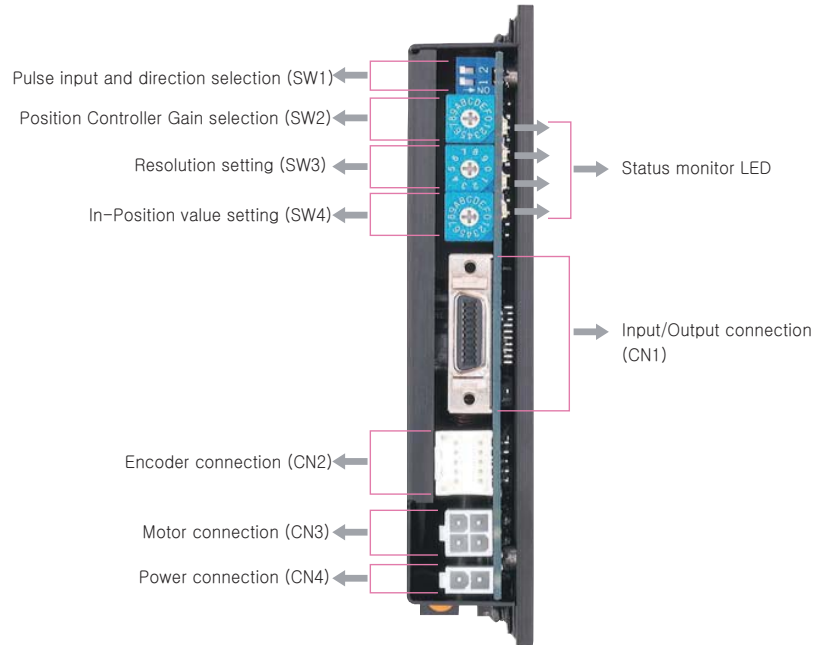

### ■ 86mm motor drive only(EzS-PD-86 Series)

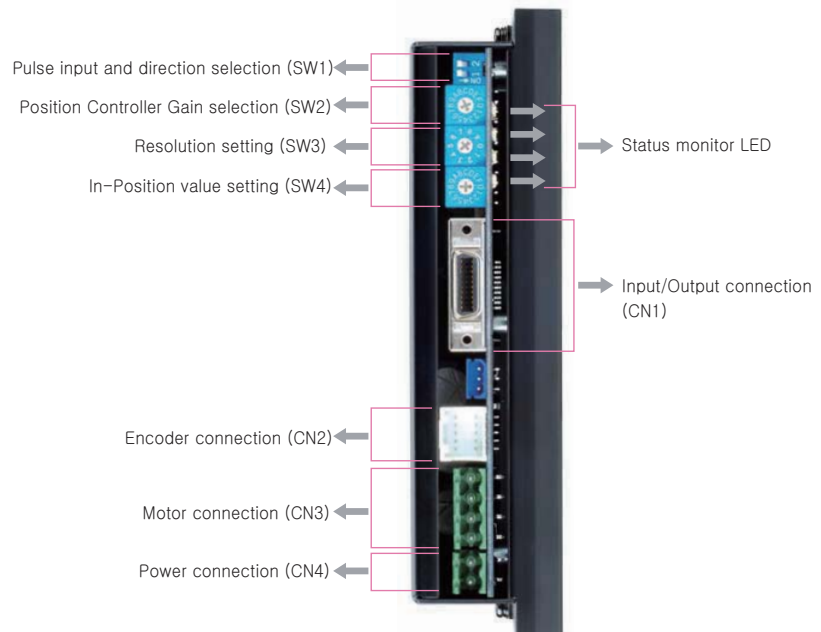

 SETTING AND OPERATING

**■ Status Monitor LED**

Indication	Color	Function	ON/OFF Condition
PWR	Green	Power Input Indication	LED is turned ON when power is applied
INP	Yellow	Complete Positioning Motion	Lights On when Positioning error reaches within the preset pulse selected by rotary switch
SON	Orange	Servo On/Off Indication	Servo On : Lights On, Servo Off : Lights Off
ALM	Red	Alarm Indication	Flash when protection function is activated (Identifiable which protection mode is activated by counting the blinking times)

**■ Protection functions and LED flash times**

Times	Protection	Conditions
1	Over Current Error	The current through power devices in inverter exceeds the limit value
2	Over Speed Error	Motor speed exceed 3000rpm
3	Step Out Error	Position value is higher than specified value in motor stop status
4	Over Load Error	The motor is continuously operated more than 5 second under a load exceeding the max. torque
5	Over Temperature Error	Inside temperature of drive exceeds 55℃
6	Over Regenerated Voltage Error	Back-EMF more high limit value*1
7	Motor Connect Error	The power is ON without connection of the motor cable to drive
8	Encoder Connect Error	Cable connection error with Encoder connector in drive
9	Low Input Voltage Error	Power source voltage is below limited value*2
10	Inposition Error	After operation is finished,a position error occurs
11	System Error	Error occurs in drive system
12	ROM Error	Error occurs in parameter storage device(ROM)
14	Hight Input Voltage Error	Power source voltage is higher than limited value*3

\*1 Voltage limit of Back-EMF depends on motor model (Refer to the Manual)

\*2 Low limit voltage value depends on motor model (Refer to the Manual)

\*3 Limit value provided to drives depends on driver model (Refer to the Manual)

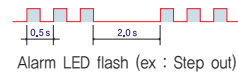
**■ Pulse Input and Motor Direction Selection Switch(SW1)**

Indication	Switch Name	기능
2P/1P	Selecting Pulse Input Mode	Selectable 1-Pulse input mode or 2-Pulse input mode as Pulse input signal. ON : 1-Pulse mode / OFF : 2-Pulse mode ※Default : 2-Pulse mode
DIR	Switching Rotational Direction	Based on CW(+Dir signal)input to driver. ON : CCW(-Direction) / OFF : CW(+Direction) ※Default : CW mode

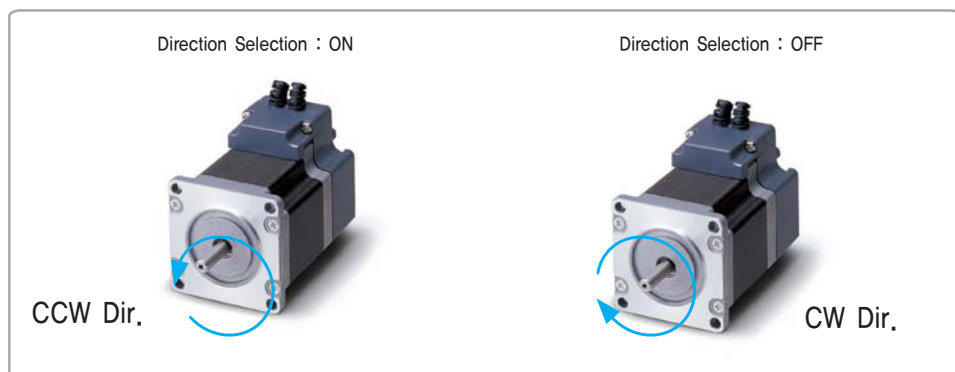

# Pulse Input Drive Setting and Operating

## SETTING AND OPERATING

### Position Controller Gain Selection Switch(SW2)

The Position Controller Gain Switch allows for the correction of the motor position deviation after stopping caused by load and friction. Depending on the motor load, the user may have to select a different gain position to stabilize and to correct positional error quickly.

To tune the controller

1. Set the switch to "0" Position.
2. Start to rotate the switch until system becomes stable.
3. Rotate the switch +/- 1 ~ 2 position to reach better performance.

Position	Time Constant of the Integral part	Proportional Gain <sup>*1</sup>
0	1	1
1	1	2
2	1	3
3 <sup>*2</sup>	1	4
4	1	5
5	1	6
6	2	1
7	2	2
8	2	3
9	2	4
A	2	5
B	3	1
C	3	2
D	3	3
E	3	4
F	3	5



<sup>\*1</sup> Value in the columns are in relative units. They only show the parameter changes depending on the switch's position.  
<sup>\*2</sup> Default = 4

### Resolution Selection Switch (SW3)

The Number of pulse per revolution.

Position	Pulse/Rotation	Position	Pulse/Rotation
0	500 <sup>*1</sup>	5	3,600
1	500	6	5,000
2	1,000	7	6,400
3	1,600	8	7,200
4	2,000	9	10,000 <sup>*2</sup>

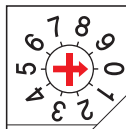

<sup>\*1</sup> Position '0' Resolution Value Depends on Encodertype. when use 16000, 20000, 32000 Resolution Encoder, Resolution sets as 16000, 20000, 32000

<sup>\*2</sup> Default = 10,000

### Position Value Setting switch(SW4)

To select the output condition of In-position signal. In-position output signal is generated when the pulse number of positional error is lower than selected In-position value set by this switch after positioning command is executed.

Position	In-Position Value [Pulse]Fast Response	Position	In-Position Value [Pulse]Fast Response
0 <sup>*1</sup>	0	8	0
1	1	9	1
2	2	A	2
3	3	B	3
4	4	C	4
5	5	D	5
6	6	E	6
7	7	F	7



<sup>\*1</sup> Default = 0

\* Please refer to User Manual for setup.

### ■ Motor Connector(CN3)

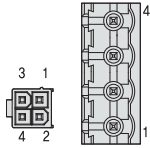

NO.	Function	NO.	Function
1	APhase	1	/BPhase
2	BPhase	2	BPhase
3	/APhase	3	/APhase
4	/BPhase	4	APhase

### ■ Power Connector(CN4)

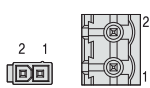

NO.	Function	NO.	Function
1	24VDC±10%	1	GND
2	GND	2	40~70VDC

### ■ Encoder Connector(CN2)

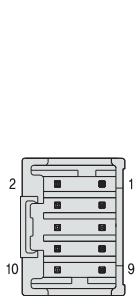

NO.	Function	I/O
1	A+	Input
2	A-	Input
3	B+	Input
4	B-	Input
5	Z+	Input
6	Z-	Input
7	5VDC	Output
8	5VDC GND	Output
9	Frame GND	----
10	Frame GND	----

### ■ Input / Output Signal(CN1)

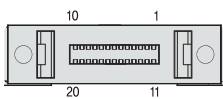

NO.	Function	I/O
1	CW+(Pulse+)	Input
2	CW-(Pulse-)	Input
3	CCW+(Dir+)	Input
4	CCW-(Dir-)	Input
5	A+	Output
6	A-	Output
7	B+	Output
8	B-	Output
9	Z+	Output
10	Z-	Output
11	Alarm	Output
12	In-Position	Output
13	Servo On/Off	Input
14	Alarm Reset	Input
15	NC	-
16	BRAKE+	Output
17	BRAKE-	Output
18	S-GND	Output
19	24VDC GND	Input
20	24VDC	Input

\* BRAKE function is optional

\* There is no BRAKE function for 86mm motor drive.



# Pulse Input Drive Setting and Operating

## SYSTEM CONFIGURATION OF PULSE INPUT DRIVE

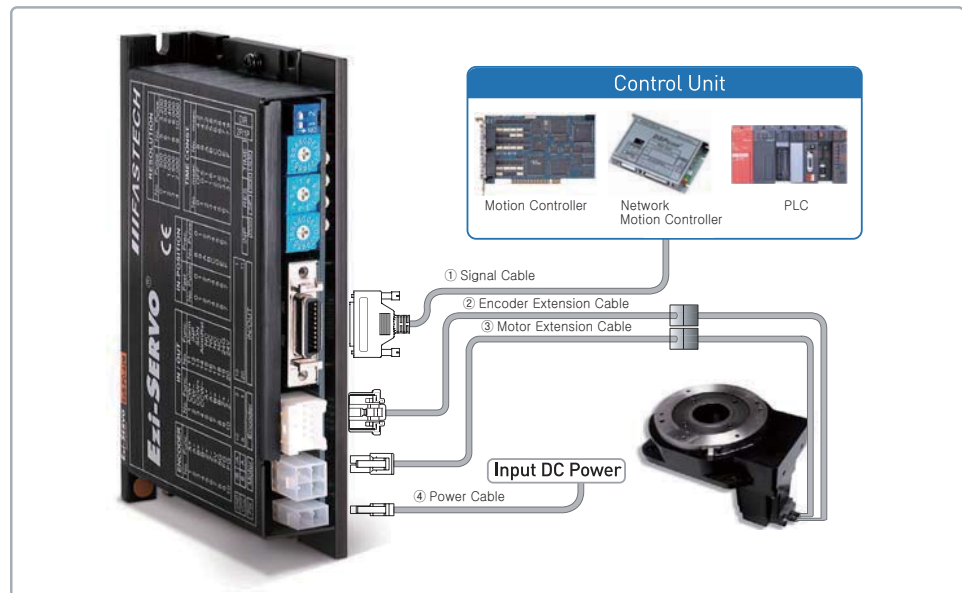

Type	Power Cable	Motor Cable	Encoder Cable	Signal Cable
Standard Length	-	30cm	30cm	-
Max.Length	2m	20m	20m	20m

### ■ Cable Option

#### 1. Signal Cable

Available to connect between Control System and Ezi-SERVO.

Item	Length [m]	Remark
CSVO-S-□□□F	□ □ □	Normal Cable
CSVO-S-□□□M	□ □ □	Robot Cable

□ is for Cable Length. The unit is 1m and Max. 20m length.

#### 2. Encoder Extension Cable

Available to extended connection between Encoder and Ezi-SERVO.

Item	Length [m]	Remark
CSVO-E-□□□F	□ □ □	Normal Cable
CSVO-E-□□□M	□ □ □	Robot Cable

□ is for Cable Length. The unit is 1m and Max. 20m length.

#### 3. Motor Extension Cable

Available to extended connection between motor and Ezi-SERVO.

Item	Length [m]	Remark
CSVO-M-□□□F	□ □ □	Normal Cable
CSVO-M-□□□M	□ □ □	Robot Cable

□ is for Cable Length. The unit is 1m and Max. 20m length.

#### 4. Power Cable

Available to connect between Power and Ezi-SERVO.

Item	Length [m]	Remark
CSVO-P-□□□F	□ □ □	Normal Cable
CSVO-P-□□□M	□ □ □	Robot Cable

□ is for Cable Length. The unit is 1m and Max. 2m length.

**SYSTEM CONFIGURATION OF PULSE INPUT DRIVE(86mm Motor)**

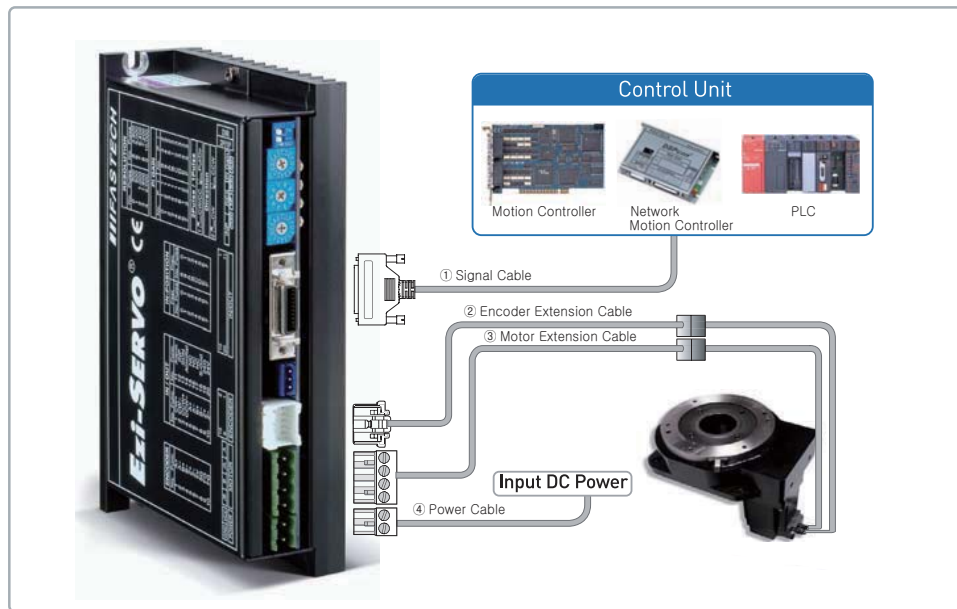

Type	Power Cable	Motor Cable	Encoder Cable	Signal Cable
Standard Length	-	30cm	30cm	-
Max.Length	2m	20m	20m	20m

**■ Cable Option**

**1. Signal Cable**

Available to connect between Control System and Ezi-SERVO.

Item	Length [m]	Remark
CSVO-S-□□□F	□ □ □	Normal Cable
CSVO-S-□□□M	□ □ □	Robot Cable

□ is for Cable Length.The unit is 1m and Max, 20m length.

**2. Encoder Extension Cable**

Available to extended connection between Encoder and Ezi-SERVO.

Item	Length [m]	Remark
CSVO-E-□□□F	□ □ □	Normal Cable
CSVO-E-□□□M	□ □ □	Robot Cable

□ is for Cable Length.The unit is 1m and Max, 20m length.

**3. Motor Extension Cable**

Available to extended connection between motor and Ezi-SERVO.

Item	Length [m]	Remark
CSVO-M-□□□F	□ □ □	Normal Cable
CSVO-M-□□□M	□ □ □	Robot Cable

□ is for Cable Length.The unit is 1m and Max, 20m length.

**4. Power Cable**

Available to connect between Power and Ezi-SERVO.

Item	Length [m]	Remark
CSVO-P-□□□F	□ □ □	Normal Cable
CSVO-P-□□□M	□ □ □	Robot Cable

□ is for Cable Length.The unit is 1m and Max, 2m length.

# Pulse Input Drive Setting and Operating Control I/O Signals

 PULSE INPUT DRIVE EXTERNAL WIRING DIAGRAM

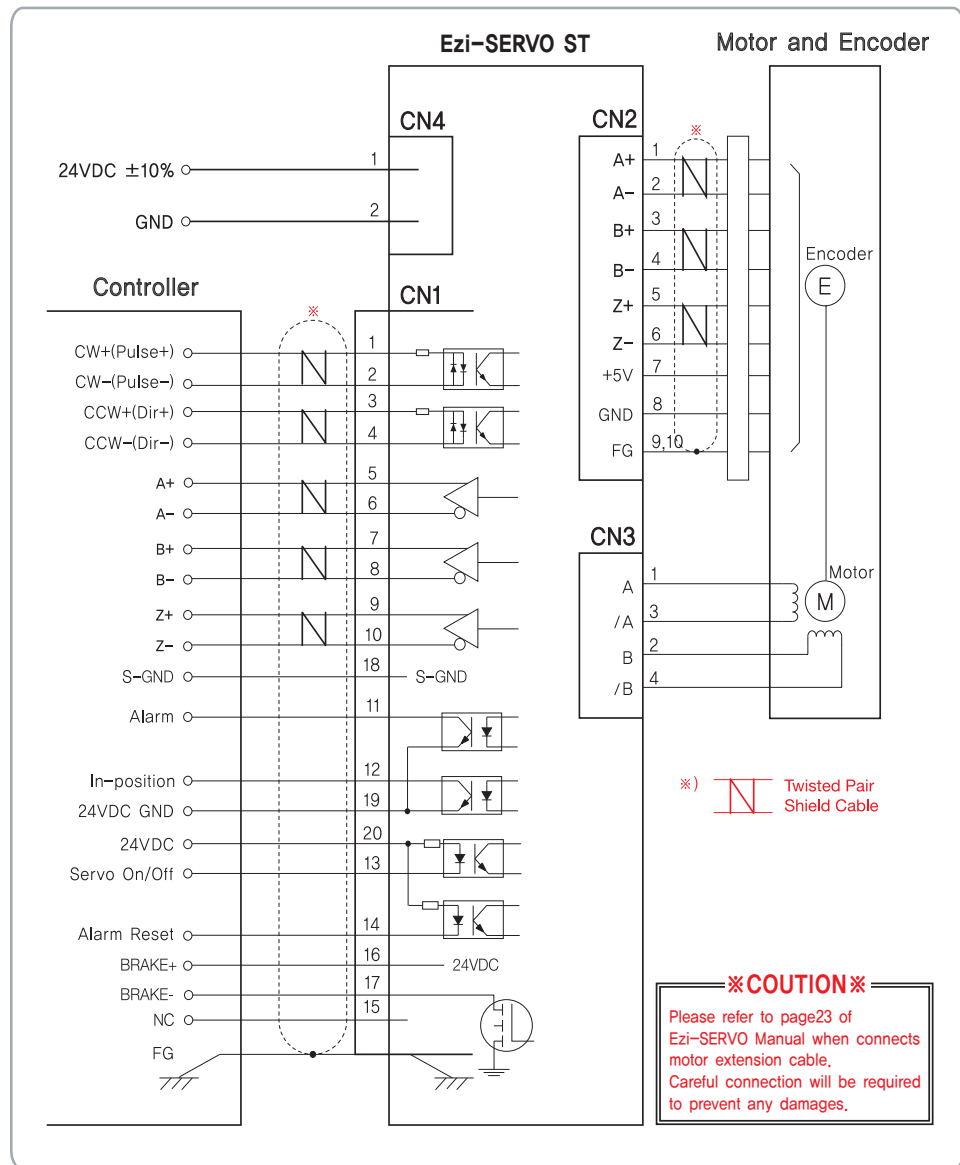

 PULSE INPUT DRIVE EXTERNAL WIRING DIAGRAM(86mm Motor)

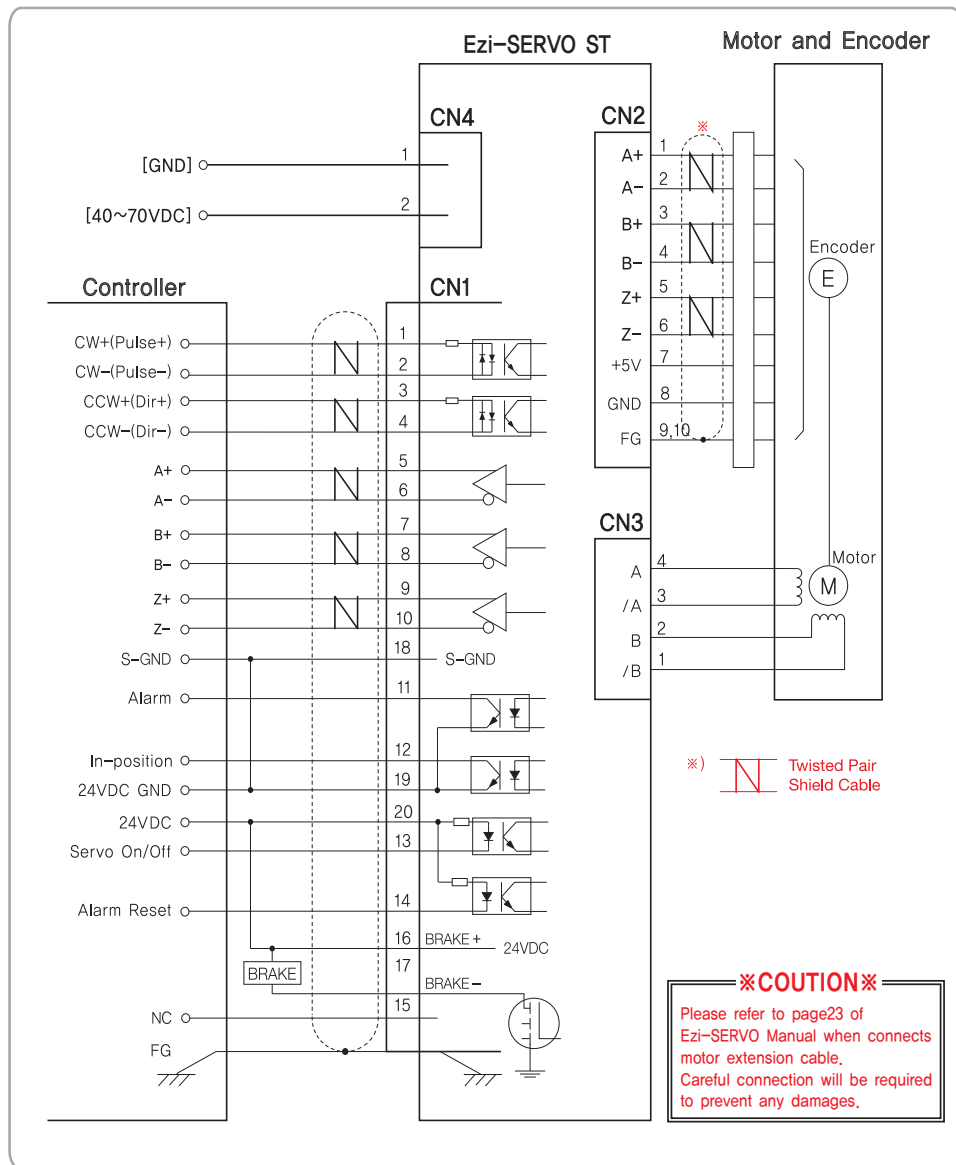

## INPUT SIGNAL

Input signals of the drive are all hotocoupler protected, the signal shows the status of internal hotocouplers [ON: onduction], OFF: on-conduction ], or isplaying the voltage levels f the signal.

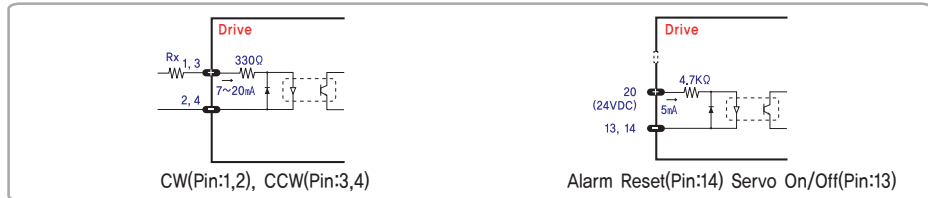

### ■ CW, CCW Input

This signal can be used to receive a positioning pulse command from a user host motion controller.

The user can select 1-pulse input mode or 2-pulse input mode (refer to witch No.11, W1).The input schematic of CW, CCW is designed for 5V TTL level. When using 5V level as an input signal, the resistor Rx is not used and connect to he river directly. When the level of input signal is more than 5V, Rx resistor is re-quired, of the resistor is absent, the drive will be amaged! If the input signal level is 12V, Rx value is 680ohm and 24V, Rx value is . 1.8kohm.

### ■ Servo On/Off Input

This input can be used only to djust the position by manually moving the motor shaft from the load-side. By setting the signal [ON], the driver cuts off the power supply to the motor. Then, one can manually adjust output position. When setting the signal back to [OFF ],the driver resumes the power to the motor and recovers the holding torque. When driving a motor, one needs to set the signal [OFF].



※ By setting thea larm eset nput signal [ON], ancel the Alarm output. Before ancel the Alarm output, have to remove the source of alarm.

### ■ Alarm Reset Input

When a protection mode has been activated, a signal to this alarm reset input cancels the Alarm output.

## OUTPUT SIGNAL

Output signals from the driver are hotocoupler protected: alarm, in-Position and the line Driver utputs (encoder signal). In the case of hotocoupler outputs, the signal indicates the status of internal hotocouplers ON: onduction], OFF: non-conduction ], not isplaying the voltage levels of the signal.

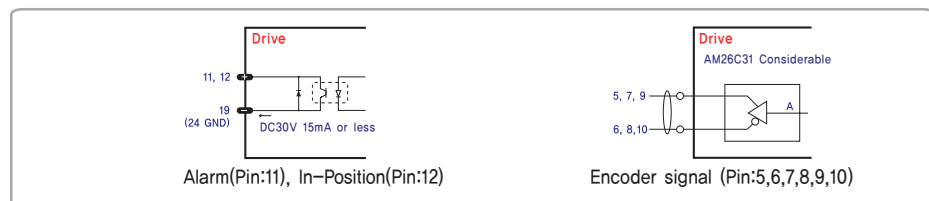

### ■ Alarm Output

The Alarm output indicates [ON] when the driver is in a normal operation. If a protection mode has been activated, it goes [OFF ].A host controller needs to detect this signal and stop sending a motor driving command. When the driver detects an abnormal operation such as overload or over current of the motor, it sets the Alarm output to [OFF ], flashes the Alarm LED, disconnect the power to a motor and stops the motor simultaneously.

[Caution] Only at the Alarm output port, the photocoupler isolation is reverse. When the driver is in normal operation the Alarm output is [ON]. On the contrary when the driver is in abnormal operation that start protection mode, the alarm output is [OFF].

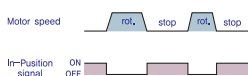

### ■ In-Position Output

In-Position signal is [ON] when positioning is completed. This signal is [ON] when the motor position error is within the value set by he witch SW4.

### ■ Encoder signal Output

The encoder signal is a line driver output, this can be used to confirm the stop position.

# Controller Embedded Drive Setting and Operating

## CONTROLLER EMBEDDED DRIVE SETTING AND OPERATING

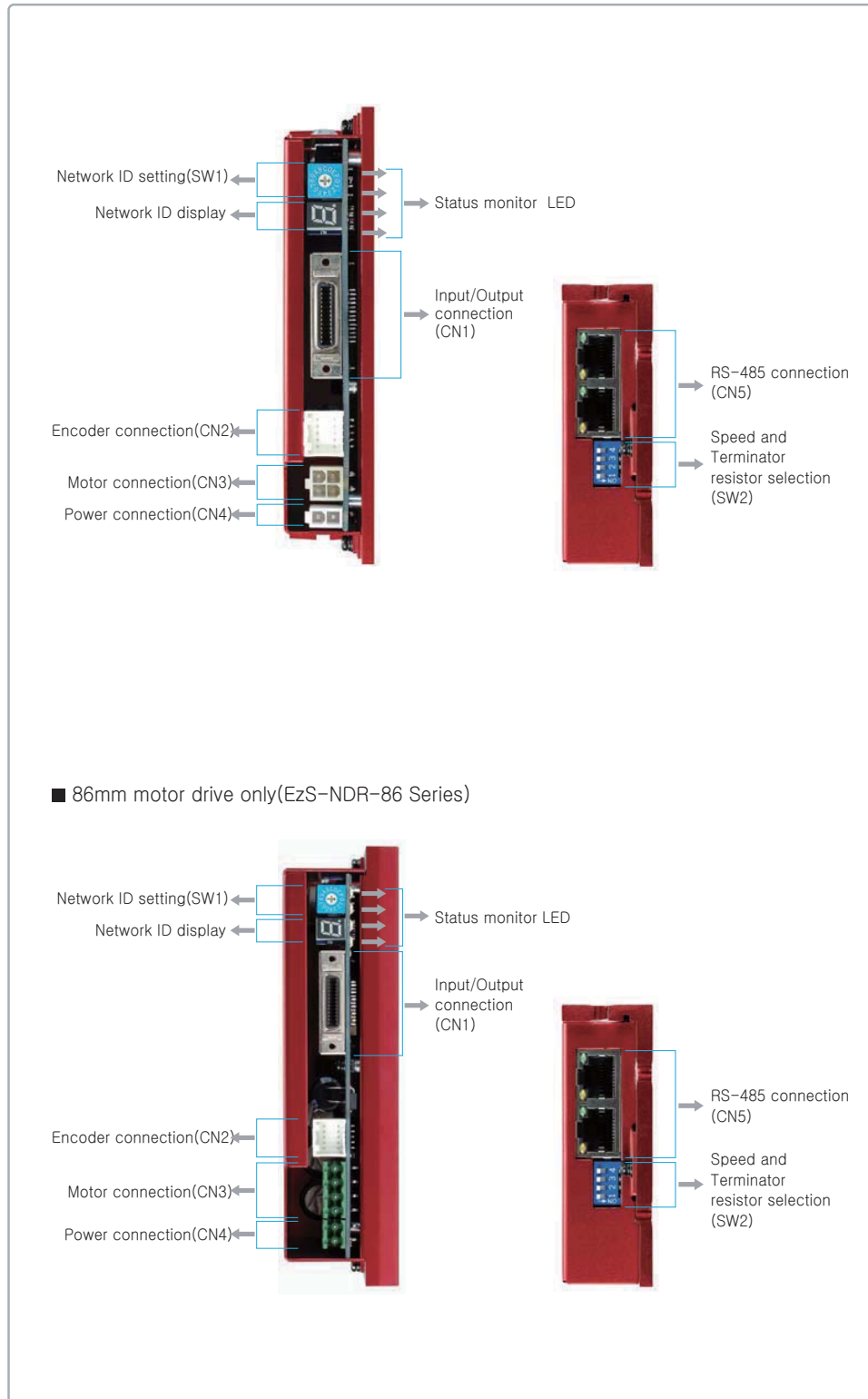

### 1. Status Monitor LED

Indication	Color	Function	ON/OFF Condition
PWR	Green	Power Input Indication	LED is turned ON when power is applied
INP	Yellow	Complete Positioning Motion	Lights On when Positioning error reaches within the preset pulse selected by rotary switch
SON	Orange	Servo On/Off Indication	Servo On : Lights On, Servo Off : Lights Off
ALM	Red	Alarm Indication	Flash when protection function is activated (Identifiable which protection mode is activated by counting the blinking times)

#### Protection functions and LED flash times

Times	Protection	Conditions
1	Over Current Error	The current through power devices in inverter exceeds the limit value
2	Over Speed Error	Motor speed exceed 3000rpm
3	Position Tacking Error	Position value is higher than specified value in motor stop status
4	Over Load Error	The motor is continuously operated more than 5 second under a load exceeding the max,torque
5	Over Temperature Error	Inside temperature of drive exceeds 55°C
6	Over Regeneratived Voltage Error	Back-EMF more high limit value*1
7	Motor Connect Error	The power is ON without connection of the motor cable to drive
8	Encoder Connect Error	Cable connection error with Encoder connector in drive
9	Low Input Voltage Error	Power source voltage is below limited value*2
10	Inposition Error	After operation is finished,a position error occurs
11	System Error	Error occurs in drive system
12	ROM Error	Error occurs in parameter storage device(ROM)
14	Input Voltage Error	Power source voltage is higher than limited value*3



Alarm LED flash  
(ex : Position tracking error)

\*1 Voltage limit of Back-EMF depends on motor model (Refer to the Manual)

\*2 Low limit voltage value depends on motor model (Refer to the Manual)

### 2. Network ID Selection Switch(SW1)

Position	ID number	Position	ID number
0	0	8	8
1	1	9	9
2	2	A	10
3	3	B	11
4	4	C	12
5	5	D	13
6	6	E	14
7	7	F	15



\* Maximum 16 axis can be connected in one network.

### 3. Encoder Connector(CN2)

NO.	Function	I/O
1	A+	Input
2	A-	Input
3	B+	Input
4	B-	Input
5	Z+	Input
6	Z-	Input
7	5VDC	Output
8	5VDC GND	Output
9	F. GND	----
10	F. GND	----

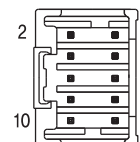

### 4. Speed and Terminator Resistor Selection Switch(SW2)

The purpose of this is to setting the communication speed andconnect a terminator resistor if drive is installed at the end of network.

SW 2,1 used for connecting the terminator resistor, SW 2,2~SW 2,4 used for setting speed as follows.

SW 2,1	SW 2,2	SW 2,3	SW 2,4	Baud rate[bps]
-	OFF	OFF	OFF	9,600
-	ON	OFF	OFF	19,200
-	OFF	ON	OFF	38,400
-	ON	ON	OFF	57,600
-	OFF	OFF	ON	115,200*1
-	ON	OFF	ON	230,400
-	OFF	ON	ON	460,800
-	ON	ON	ON	921,600

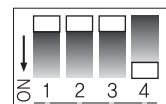

\*1 : Default setting value

If SW2,1 is OFF,terminator resistor is disconnected.

If SW2,2 is ON,terminator resistor is connected.

\* PCI Bus type RS-485 communication board can be used to realize high speed communication. (Please contact our sales agency)



# Controller Embedded Drive Setting and Operating

## SETTING AND OPERATING

### 5. Motor Connector(CN3)



NO.	Function
1	A 상
2	B 상
3	/A 상
4	/B 상

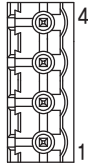

NO.	Function
1	B/상
2	B상
3	A/상
4	A상

\* Only for 86mm motor drive.

### 6. Power Connector(CN4)



NO.	Function
1	24VDC ±10%
2	GND

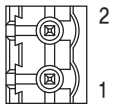

NO.	Function
1	GND
2	40~70VDC

\* Only for 86mm motor drive.

### 8. Input/Output Signal(CN1)

NO.	Function	I/O
1	LIMIT+	Input
2	LIMIT-	Input
3	ORIGIN	Input
4	Digital In1	Input
5	Digital In6	Input
6	Digital In7	Input
7	Compare Out1	Output
8	Digital Out1	Output
9	Digital Out2	Output
10	Digital Out3	Output
11	Digital Out4	Output
12	Digital Out5	Output
13	Digital Out6	Output
14	Digital In2	Input
15	Digital In3	Input
16	Digital In4	Input
17	Digital In5	Input
18	Digital In8	Input
19	Digital In9	Input
20	Digital Out7	Output
21	Digital Out8	Output
22	Digital Out9	Output
23	BRAKE+	Output
24	BRAKE-	Output
25	24VDC GND	Input
26	24VDC	Input

※ BRAKE function is optional.

※ There is no BRAKE function for 86mm motor drive.

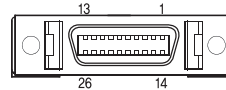

### 7. RS-485 Communication Connector(CN5)

There is converter for connecting PC.

1) RS-232 to RS-485

NO.	Function	NO.	Function
1	GND	6	Data-
2	GND	7	GND
3	Data+	8	GND
4	GND	LED 1, 3	Drive status
5	GND	LED 2, 4	Communication status

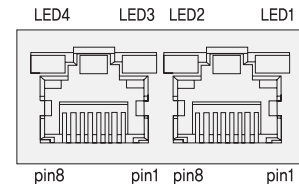

# Controller Embedded Drive System Configurations

## CONTROLLER EMBEDDED DRIVE SYSTEM CONFIGURATIONS

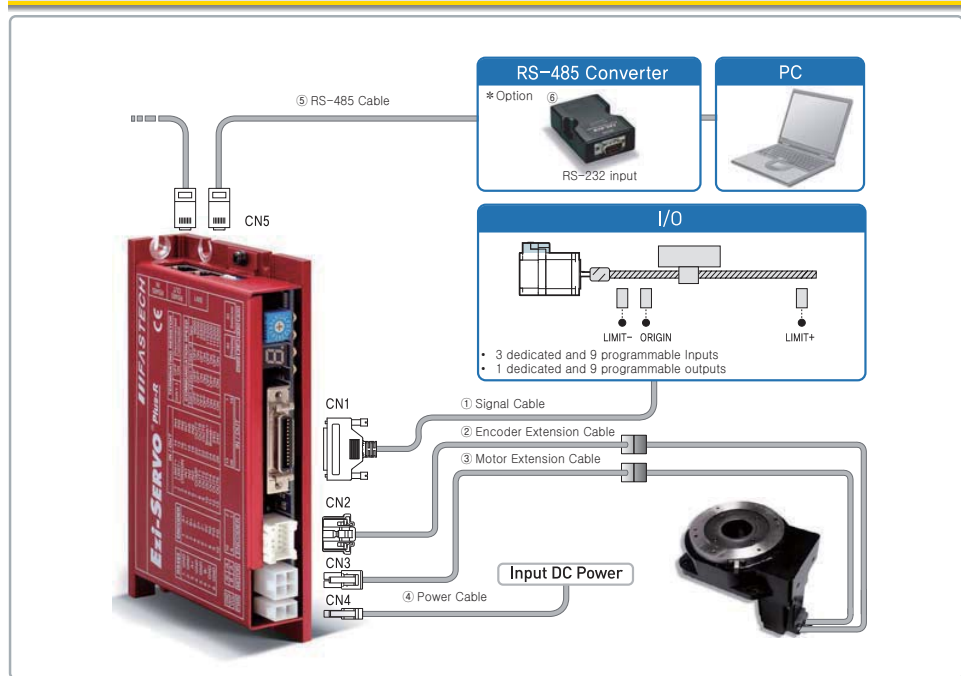

Type	Signal Cable	Encoder Cable	Motor Cable	Power Cable	RS-485 Cable
Standard Length	-	30cm	30cm	-	-
Max.Length	20m	20m	20m	2m	30m

### ■ Cable Option

#### 1. Signal Cable

Available to connect between Control System and Ezi-SERVO Plus-R.

Item	Length [m]	Remark
CSV-R-S-□□□F	□ □ □	Normal Cable
CSV-R-S-□□□M	□ □ □	Robot Cable

□ is for Cable Length, The unit is 1m and Max, 20m length.

#### 2. Encoder Extension Cable

Available to extended connection between Encoder and Ezi-SERVO Plus-R.

Item	Length [m]	Remark
CSV-O-E-□□□F	□ □ □	Normal Cable
CSV-O-E-□□□M	□ □ □	Robot Cable

□ is for Cable Length, The unit is 1m and Max, 20m length.

#### 3. Motor Extension Cable

Available to extended connection between motor and Ezi-SERVO Plus-R.

Item	Length [m]	Remark
CSV-O-M-□□□F	□ □ □	Normal Cable
CSV-O-M-□□□M	□ □ □	Robot Cable

□ is for Cable Length, The unit is 1m and Max, 20m length.

#### 4. Power Cable

Available to connect between Power and Ezi-SERVO Plus-R.

Item	Length [m]	Remark
CSV-O-P-□□□F	□ □ □	Normal Cable
CSV-O-P-□□□M	□ □ □	Robot Cable

□ is for Cable Length, The unit is 1m and Max, 2m length.

# Controller Embedded Drive System Configurations

## CONTROLLER EMBEDDED DRIVE SYSTEM CONFIGURATIONS

### 5. RS-485 Cable

Item	Length [m]	Remark
CGNR-R-0R6F	0,5	Normal Cable
CGNR-R-001F	1	
CGNR-R-1R5F	1,5	
CGNR-R-002F	2	
CGNR-R-003F	3	
CGNR-R-005F	5	

### ■ Option

#### 6. FAS-RCR (RS-232C to RS-485 Converter)

Item	Specification
Comm.Speed	Max.115,2Kbps
Comm.Distance	RS-232C :Max.15m RS-485 :Max.1,2km
Connector Type	RS-232C : DB9 Female, RS-485 : RJ-45
Operating System	Windows 98/2000/XP/Vista
Dimension	50X75X23mm
Weight	38g
Power	Powered from PC (Usable for external DC5~24V)

### RS-232C Cable

Item	Length [m]	Remark
CGNR-C-002F	2	Normal Cable
CGNR-C-003F	3	
CGNR-C-005F	5	

### 7. TB-Plus(Interface Board)

Available to connect more conveniently between Input/Output signal and Ezi-SERVO Plus-R.

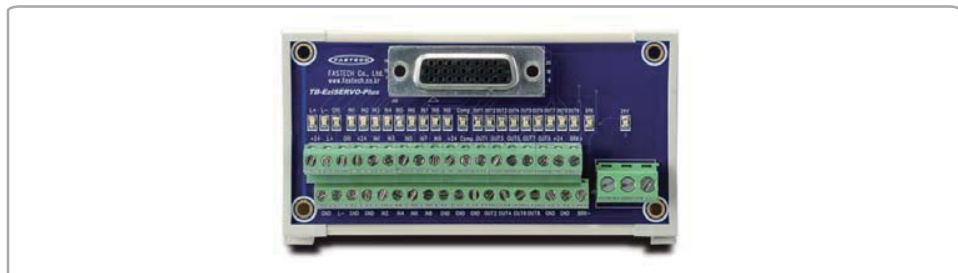

### Interface Cable

Available to Connect between TB-Plus Interface Board and Ezi-SERVO Plus-R.

Item	Length [m]	Remark
CIFD-S-□□□F	□ □ □	Normal Cable
CIFD-S-□□□M	□ □ □	Robot Cable

□ is for Cable Length. The unit is 1m and Max.20m length.

 CONTROLLER EMBEDDED DRIVE SYSTEM CONFIGURATIONS(86mm Motor)

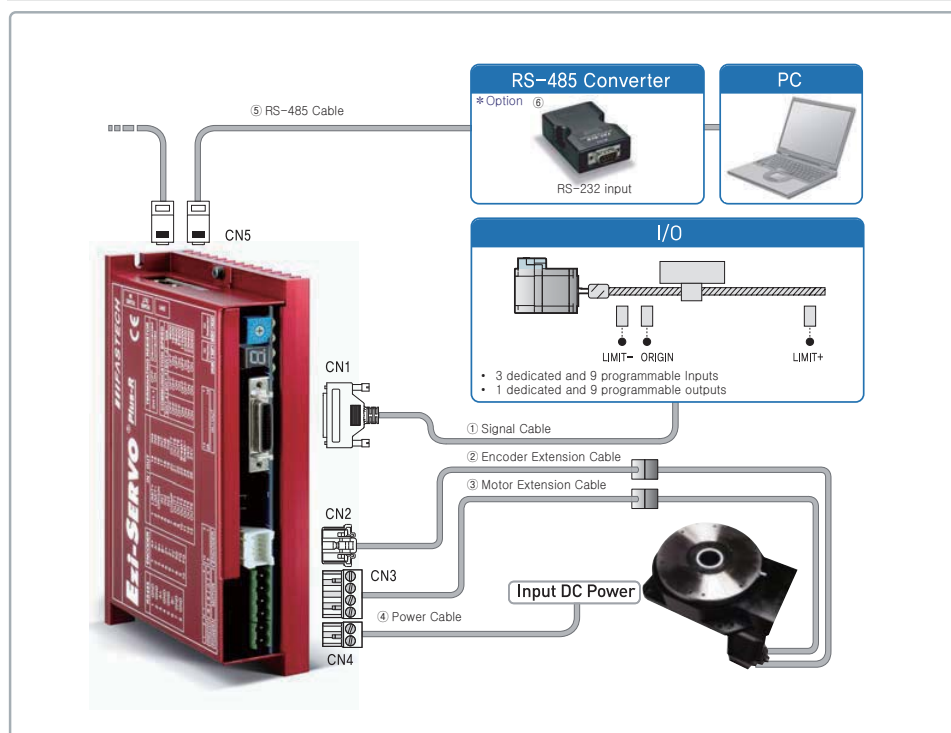

■ Cable Option

1. Signal Cable

Available to connect between Control System and Ezi-SERVO Plus-R.

Item	Length [m]	Remark
CSVO-S-□□□F	□ □ □	Normal Cable
CSVO-S-□□□M	□ □ □	Robot Cable

□ is for Cable Length, The unit is 1m and Max, 20m length.

2. Encoder Extension Cable

Available to extended connection between Encoder and Ezi-SERVO Plus-R.

Item	Length [m]	Remark
CSVO-E-□□□F	□ □ □	Normal Cable
CSVO-E-□□□M	□ □ □	Robot Cable

□ is for Cable Length, The unit is 1m and Max, 20m length.

3. Motor Extension Cable

Available to extended connection between motor and Ezi-SERVO Plus-R.

Item	Length [m]	Remark
CSVO-M-□□□F	□ □ □	Normal Cable
CSVO-M-□□□M	□ □ □	Robot Cable

□ is for Cable Length, The unit is 1m and Max, 20m length.

4. Power Cable

Available to connect between Power and Ezi-SERVO Plus-R.

Item	Length [m]	Remark
CSVO-P-□□□F	□ □ □	Normal Cable
CSVO-P-□□□M	□ □ □	Robot Cable

□ is for Cable Length, The unit is 1m and Max, 2m length.

# Controller Embedded Drive System Configurations

## CONTROLLER EMBEDDED DRIVE SYSTEM CONFIGURATIONS(86mm Motor)

### 5. RS-485 Cable

Item	Length [m]	Remark
CGNR-R-0R6F	0,5	Normal Cable
CGNR-R-001F	1	
CGNR-R-1R5F	1,5	
CGNR-R-002F	2	
CGNR-R-003F	3	
CGNR-R-005F	5	

### ■ Option

#### 6. FAS-RCR (RS-232C to RS-485 Converter)

Item	Specification
Comm.Speed	Max.115,2Kbps
Comm.Distance	RS-232C : Max.15m, RS-485 :Max.1,2km
Connector Type	RS-232C : DB9 Female, RS-485 : RJ-45
Operating System	Windows 98/2000/XP/Vista
Dimension	50X75X23mm
Weight	38g
Power	Powered from PC (Usable for external DC5~24V)

### RS-232C Cable

Item	Length [m]	Remark
CGNR-R-002F	2	Normal Cable
CGNR-R-003F	3	
CGNR-R005F	5	

### 7. TB-Plus(Interface Board)

Available to connect more conveniently between Input/Output signal and Ezi-SERVO Plus-R.

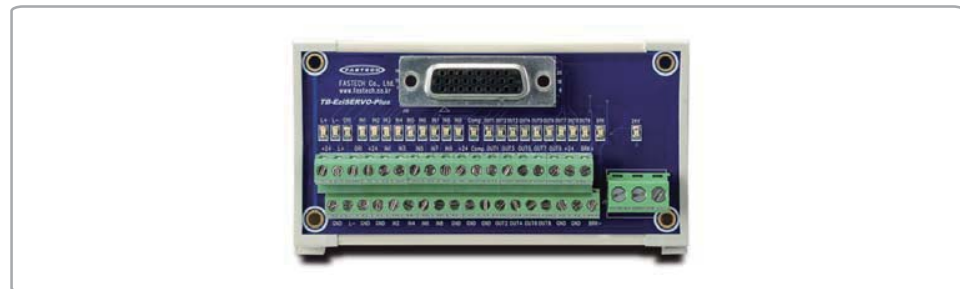

### Interface Cable

Available to Connect between TB-Plus Interface Board and Ezi-SERVO Plus-R.

Item	Length [m]	Remark
CSVO-S-□□□F	□ □ □	Normal Cable
CSVO-S-□□□M	□ □ □	Robot Cable

□ is for Cable Length. The unit is 1m and Max.20m length.

# External Wiring Diagram

## CONTROLLER EMBEDDED DRIVE EXTERNAL WIRING DIAGRAM

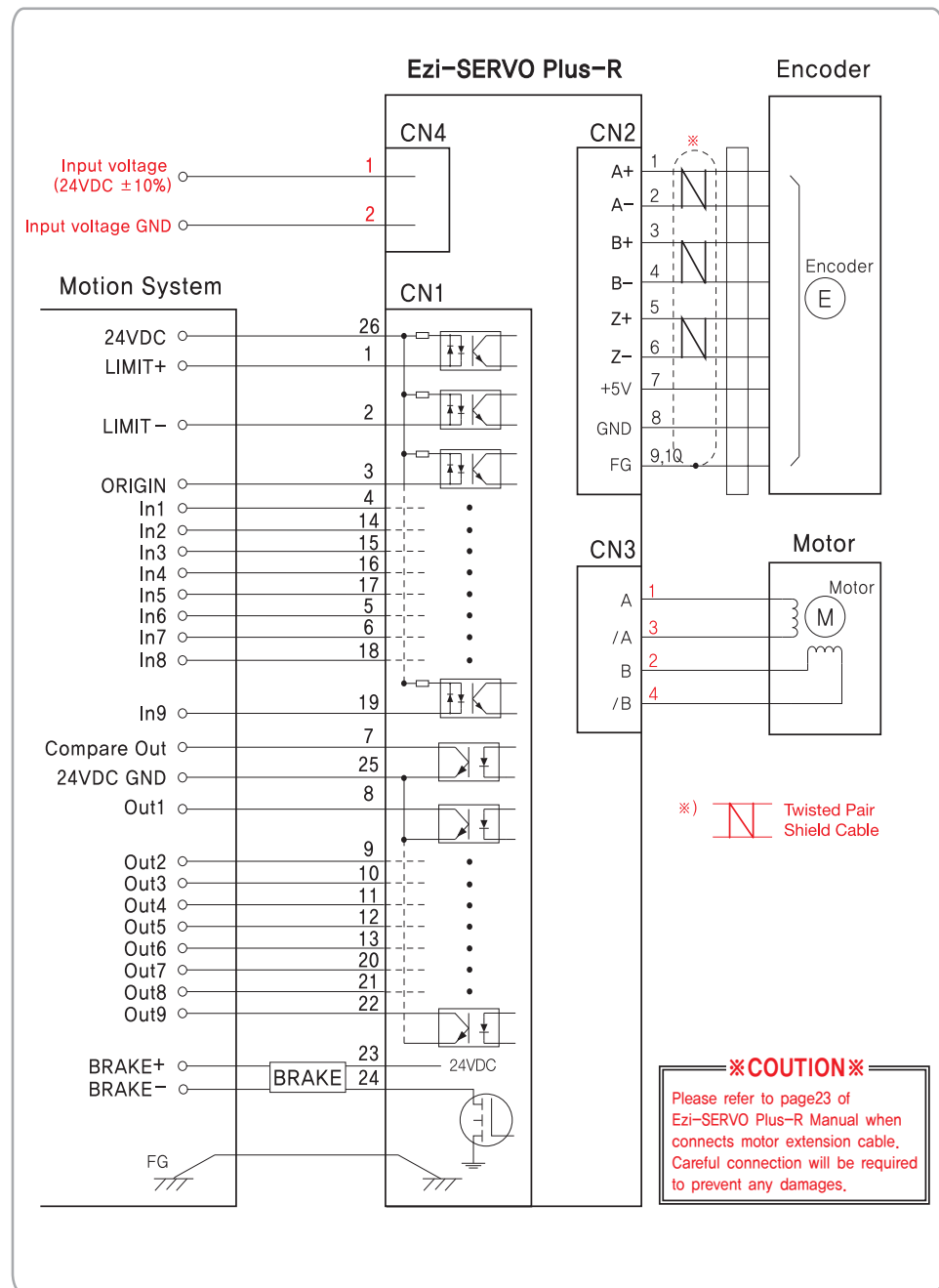

# External Wiring Diagram

CONTROLLER EMBEDDED DRIVE EXTERNAL WIRING DIAGRAM(86mm Motor)

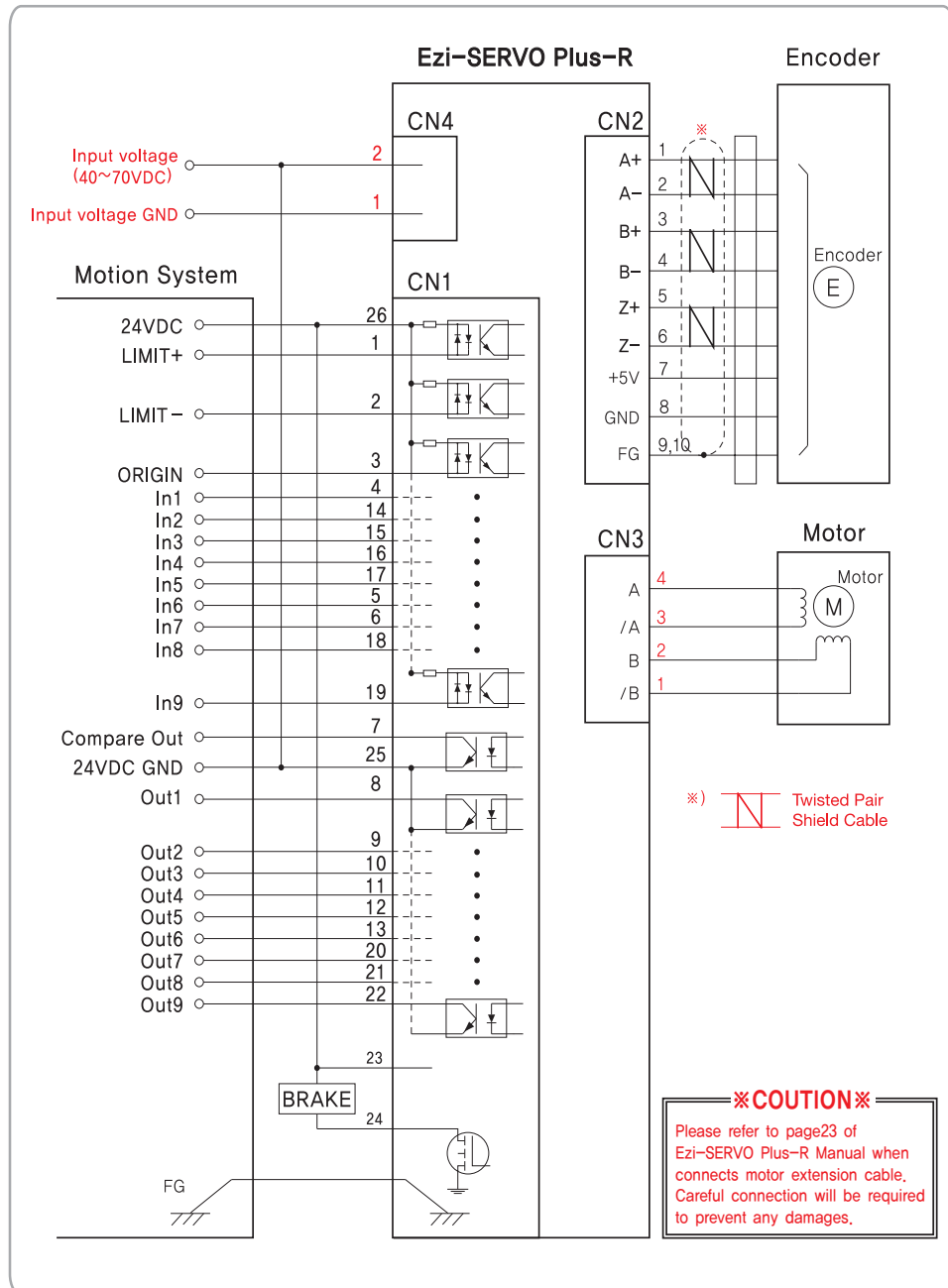



# GUI (Graphic User Interface) Screen shot

## CONTROLLER EMBEDDED DRIVE USER GUI

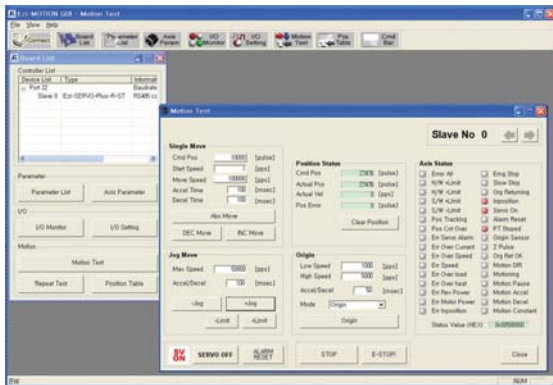

### Controller Lists and Motion Test

This screen display the controller list that connected to system, You can make a single move, jog and origin command also the motor status is displayed.

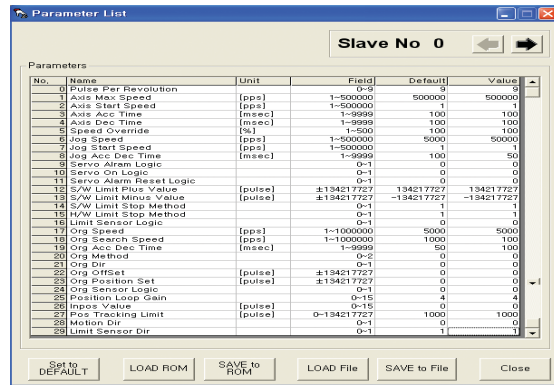

### Parameter List

All of the parameters are displayed and modified on this screen.

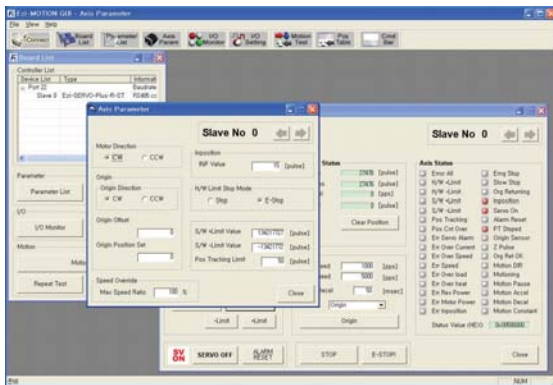

### Axis Parameter Set up

You can select various parameters that frequently used, (ex :sensor input logic)

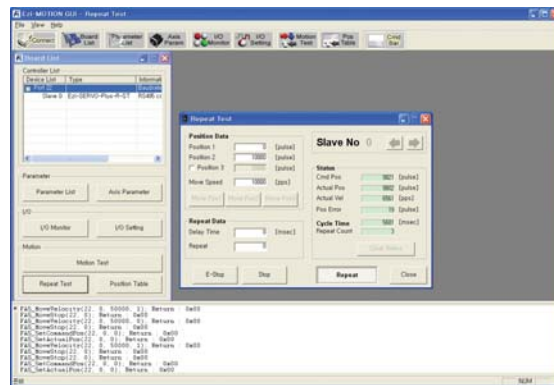

### Motion Repeat and Monitor Status

Target position, speed, delay time and repeat count are selected for repeat motion test, Motion library (DLL) is also displayed on screen.

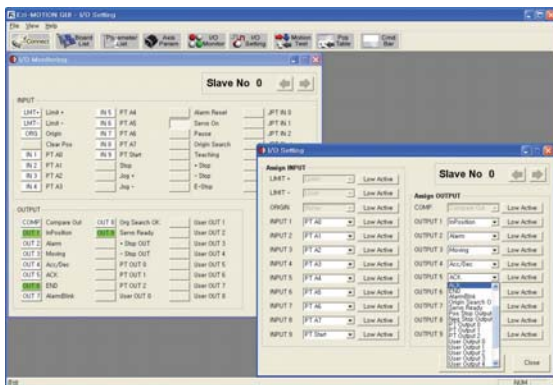

### I/O Monitoring and Setting

You can select various digital input and output signals of controller.

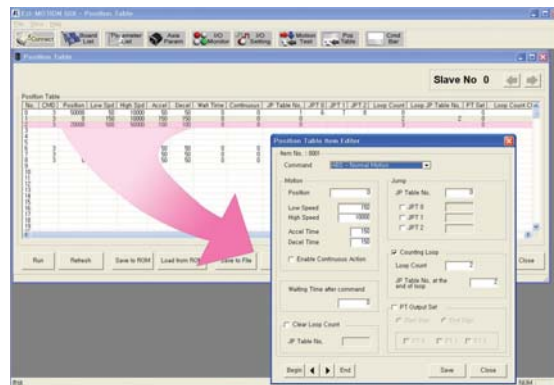

### Position Table

You can edit the position table and execute it, The position table data can be saved and loaded from Flash ROM and Windows file.

**MEMO**



*Fast, Accurate, Smooth Motion*

**FASTECH Co., Ltd.**

Rm #1202, Bucheon Technopark 401 Dong, Yakdea-dong,  
Wonmi-Gu, Bucheon-si, Gyeonggi-do, Rep. Of Korea (Zip)420-734  
TEL : 82-32-234-6300,6301 FAX : 82-32-234-6302  
E-mail : [fastech@fastech.co.kr](mailto:fastech@fastech.co.kr) Homepage : [www.fastech.co.kr](http://www.fastech.co.kr)

**FASTECH AMERICA LLC**

811 E Plano Parkway, Suite 110A, Plano, TX 75074 USA  
Toll Free: 877-905-4428 972-218-0210  
Email: [support@fastechamerica.com](mailto:support@fastechamerica.com)  
website: [www.fastechamerica.com](http://www.fastechamerica.com)