

Chipping tools Overview

- 1
- 2
- 3
- 4
- 5
- 6
- 7



379

Accessories for milling



382

Miniature carbide milling cutters/finishers Ø 1,6 mm



386

Carbide milling cutters, shank Ø 2,35 mm



381

Engraver's milling cutters HSS, shank Ø 3 mm



388

Milling cutters for processing aluminium, shank Ø 3 mm



389

Carbide milling cutters, shank Ø 3 and 6 mm



393

Carbide milling cutters Sets

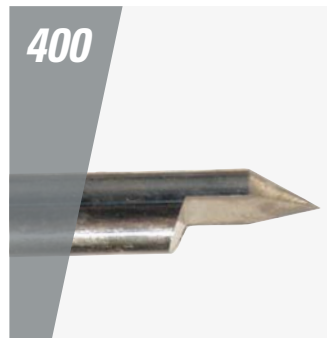

400

Gravers, solid carbide metal



402

Filing tools



406

Steel ruffle files



410

Hand deburrers



411

Deburring knife



378 Milling tools

Engraver's milling cutters HSS
Carbide milling cutters
Gravers, solid carbide metal

402 Filing tools

Steel needle files
Steel ruffle files

410 Deburring tools

Hand deburrers
Reverse deburrers
Deburring knife

4

Milling tools

380 Engraver's milling cutters in HSS

382 Milling cutters, shank Ø 1,6 mm

385 Milling cutters, shank Ø 2,35 mm

387 Milling cutters, shank Ø 3,0 mm

396 Milling cutters, shank Ø 6,0 mm

400 Circular saw blades

400 Gravers

401 Solid carbide microdrills

401 Reverse deburrer 45°

If you have always held the opinion that a milling bur is just a piece of carbide available in various shank and head sizes, you should pay particular attention to the following pages. It is worth checking the milling bur down to its teeth. Ultimately, the type of cut decides what materials it can be best used on (see illustration below).

Cutting types of the joke miling cutters:

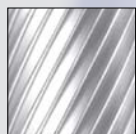

Normal cut
Even cutting performance with high stock removal



Fine cut
For delicate surfaces on tough materials



Special-G cut
For hard to chip materials, i.e. nickel, titanium, stainless steels

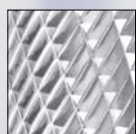

Criss-cross cut
Very good chipping with smaller chips

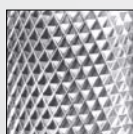

Ultrafine cut
High stock removal with very fine surface quality up to 65 HRC



INOX cut
Special geometry for working on stainless steel



Diamond cut
For fibreglass reinforced plastics, epoxy resins, phenols



Coarse cut
Wide chip intervals for aluminium, non-ferrous metals and plastics

Protection for the eyes

Protective goggles

- Clear, optically correct, single-piece PC pane
- Scratchproof coating
- casual design, extremely light (21.5 g)
- Protection against general hazards and flying particles (up to 45 m/sec.)
- Comfort pads on the temple ends
- Soft nose pad



| Protective goggles | Price from | |
|--------------------|--------------------|---------|
| | Order No. | 1 piece |
| | 0 203 083-1 | 5.40 € |

Blowing pen A must for every workplace!

Possibly the smallest blowing pen in the world. It weighs a mere 20 g and regulates the compressed air perfectly. The small aperture of 3 mm ensures that the air really only goes where it should. A must for every workplace!

| Blowing pen | Price from | |
|--|------------------|---------|
| | Order No. | 1 piece |
|  <p>For direct connection to a rapid coupling system. Dimensions: Ø12.5 x 108 mm Weight: 20 g</p> | 0 203 200 | 22.70 € |

The perfect complement

Cleaning fluid X 73016-A

- Ideal for cleaning moulds and workpieces
- Evaporates rapidly and without leaving residues
- For all metals, glass, ceramics and almost all plastics



| Order No. | Price |
|------------------|--------|
| 0 580 521 | 6.75 € |

The perfect complement

Universal-Spray joke X 73020

- five products rolled into one: corrosion protection, cleaning, water repellence, lubrication and preservation
- cleans surfaces and cares for tools



| Order No. | Price |
|------------------|--------|
| 0 580 526 | 5.45 € |

















Engraver's milling cutters in HSS

shank Ø 3 mm

Engraver's milling cutters in HSS







Ideal for fine working on steel, cast steel, alloyed and unalloyed, and on non-ferrous metals with high resistance to cutting.

Cutting speed: Vmax. 60 - 180 m/min

| | Head dimensions | Angle | Radius | Shank Ø x total length | Order No. | Price from | |
|---|-----------------|-------|---------|------------------------|------------------|------------|-----------|
| | | | | | | 1 piece | 10 pieces |
| Engraver's milling cutters in HSS, shank Ø 3 mm | | | | | | | |
| cylinder | | | | | | | |
|  | ↓ Ø 6 x 10 mm | | | Ø 3 x 42 mm | 0 500 114 | 13.95 € | 11.90 € |
| | Ø 7 x 10 mm | | | Ø 3 x 42 mm | 0 500 113 | 14.70 € | 12.55 € |
| sphere | | | | | | | |
|  | Ø 1.6 x 1.5 mm | | | Ø 3 x 38 mm | 0 500 148 | 10.35 € | 8.70 € |
| | Ø 2.3 x 2.1 mm | | | Ø 3 x 39 mm | 0 500 149 | 10.35 € | 8.70 € |
|  | ↓ Ø 3.2 x 3 mm | | | Ø 3 x 40 mm | 0 500 150 | 13.35 € | 11.40 € |
| | Ø 4 x 3.8 mm | | | Ø 3 x 41 mm | 0 500 151 | 11.35 € | 9.90 € |
| | Ø 5 x 4.8 mm | | | Ø 3 x 42 mm | 0 500 152 | 12.65 € | 10.90 € |
|  | ↓ Ø 6 x 5.6 mm | | | Ø 3 x 43 mm | 0 500 153 | 13.35 € | 11.50 € |
| | Ø 7 x 6.7 mm | | | Ø 3 x 44 mm | 0 500 154 | 14.05 € | 12.10 € |
|  | Ø 8 x 7.7 mm | | | Ø 3 x 45 mm | 0 500 155 | 15.60 € | 13.25 € |
| round cone | | | | | | | |
|  | ↓ Ø 7 x 10 mm | | | Ø 3 x 42 mm | 0 500 107 | 13.95 € | 11.90 € |
| flame | | | | | | | |
|  | Ø 7 x 12 mm | | | Ø 3 x 44 mm | 0 500 115 | 13.95 € | 11.90 € |
| lens | | | | | | | |
|  | ↓ Ø 8 x 2 mm | | | Ø 3 x 39 mm | 0 500 164 | 15.60 € | 13.25 € |
| | Ø 10 x 2.5 mm | | | Ø 3 x 40 mm | 0 500 165 | 17.85 € | 15.40 € |
|  | ↓ Ø 12 x 3 mm | | 14 mm | Ø 3 x 40 mm | 0 500 166 | 22.35 € | 19.50 € |
| | Ø 14 x 3.5 mm | | 15.5 mm | Ø 3 x 41 mm | 0 500 167 | 26.55 € | 22.80 € |
| wheel, radius | | | | | | | |
|  | ↓ Ø 8 x 2 mm | | 1.1 mm | Ø 3 x 39 mm | 0 500 168 | 14.60 € | 12.55 € |
| | Ø 10 x 2.3 mm | | 1.3 mm | Ø 3 x 39 mm | 0 500 169 | 17.85 € | 15.40 € |
|  | Ø 12 x 2.6 mm | | 1.4 mm | Ø 3 x 40 mm | 0 500 170 | 22.35 € | 19.50 € |
| | Ø 14 x 3 mm | | 1.6 mm | Ø 3 x 40 mm | 0 500 171 | 24.30 € | 20.65 € |
| wheel, flat | | | | | | | |
|  | ↓ Ø 6 x 1 mm | | | Ø 3 x 38 mm | 0 500 172 | 14.25 € | 12.10 € |
| | Ø 8 x 1 mm | | | Ø 3 x 38 mm | 0 500 173 | 14.60 € | 12.55 € |
| | Ø 10 x 1 mm | | | Ø 3 x 38 mm | 0 500 174 | 16.95 € | 14.80 € |
| pointed cone 35° | | | | | | | |
|  | Ø 1.6 x 2.8 mm | 35° | | Ø 3 x 40 mm | 0 500 140 | 10.85 € | 9.20 € |
|  | ↓ Ø 2.3 x 4 mm | 35° | | Ø 3 x 41 mm | 0 500 141 | 10.85 € | 9.20 € |
| | Ø 3.2 x 5.6 mm | 35° | | Ø 3 x 43 mm | 0 500 142 | 9.60 € | 8.10 € |
|  | Ø 4 x 7 mm | 35° | | Ø 3 x 44 mm | 0 500 143 | 9.60 € | 8.20 € |
| | Ø 5 x 8.7 mm | 35° | | Ø 3 x 46 mm | 0 500 144 | 11.15 € | 9.80 € |
|  | ↓ Ø 6 x 10.5 mm | 35° | | Ø 3 x 46 mm | 0 500 145 | 12.30 € | 10.70 € |
| | Ø 7 x 12.5 mm | 35° | | Ø 3 x 46 mm | 0 500 146 | 13.65 € | 11.60 € |
| | Ø 8 x 14 mm | 35° | | Ø 3 x 46 mm | 0 500 147 | 15.10 € | 12.80 € |

Engraver's milling cutters in HSS

shank \varnothing 3 mm

| | Head dimensions | Angle | Radius | Shank \varnothing x total length | Order No. | Price from | |
|---|--------------------------|-------|--------|------------------------------------|------------------|------------|-----------|
| | | | | | | 1 piece | 10 pieces |
| pointed cone 70° | | | | | | | |
|  | \varnothing 4 x 2.8 mm | 70° | | \varnothing 3 x 40 mm | 0 500 127 | 9.80 € | 8.20 € |
|  | \varnothing 6 x 4.2 mm | 70° | | \varnothing 3 x 41 mm | 0 500 129 | 12.00 € | 10.50 € |
|  | \varnothing 8 x 5.5 mm | 70° | | \varnothing 3 x 43 mm | 0 500 131 | 13.85 € | 11.90 € |
| conical point 70° cyl. | | | | | | | |
|  | \varnothing 6 x 6 mm | 70° | | \varnothing 3 x 43 mm | 0 500 137 | 12.00 € | 10.30 € |
|  | \varnothing 8 x 8 mm | 70° | | \varnothing 3 x 45 mm | 0 500 139 | 15.30 € | 13.10 € |
| trapeze | | | | | | | |
|  | \varnothing 7 x 7.5 mm | | | \varnothing 3 x 40 mm | 0 500 106 | 15.70 € | 13.35 € |
| drop | | | | | | | |
|  | \varnothing 8 x 11 mm | | | \varnothing 3 x 43 mm | 0 500 108 | 15.10 € | 12.80 € |







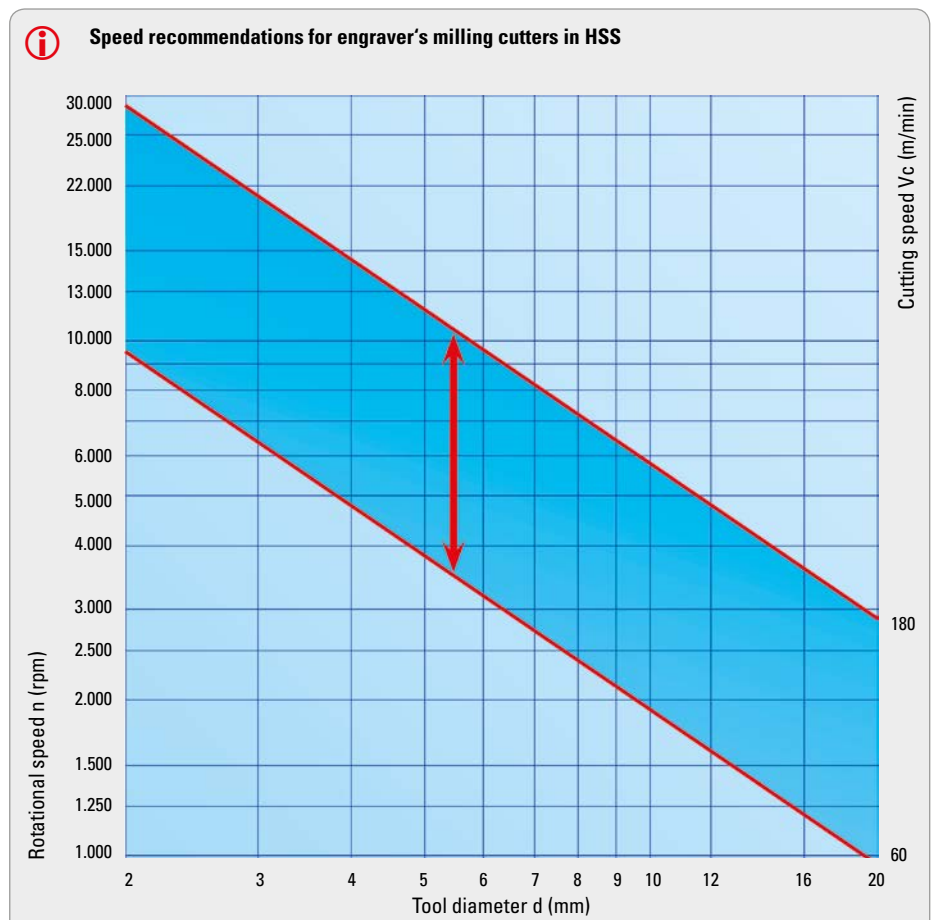







 *matching set*







| | Order No. | Price from | |
|---|-----------|------------------|----------|
| | | 1 set | |
| Set of engraver's milling cutters, HSS | | | |
| contents: | 15 pieces | 0 500 100 | 205.00 € |



Carbide milling cutters/finishers shank \varnothing 1,6 mm

| | Head dimensions | Shank \varnothing x total length | Cut | Packing quantity | Order No. | Price from 1 piece |
|---|----------------------------|------------------------------------|----------------|------------------|--------------------|-----------------------|
| Carbide milling cutters/finishers, shank \varnothing 1.6 mm | | | | | | |
| cylinder | | | | | | |
|  | \varnothing 0.8 x 3.6 mm | \varnothing 1.6 x 19 mm | standard | 5 pieces | 0 502 260-1 | 6.25 € |
| | \varnothing 0.9 x 4.0 mm | \varnothing 1.6 x 19 mm | standard | 5 pieces | 0 502 353 | 4.56 € |
| | \varnothing 1.2 x 4.5 mm | \varnothing 1.6 x 19 mm | standard | 5 pieces | 0 502 355 | 4.56 € |
| | \varnothing 1.4 x 4.5 mm | \varnothing 1.6 x 19 mm | standard | 5 pieces | 0 502 205-1 | 5.25 € |
| sphere | | | | | | |
|  | \varnothing 0.5 x 0.4 mm | \varnothing 1.6 x 19 mm | standard | 5 pieces | 0 502 899 | 4.56 € |
| | \varnothing 0.6 x 0.5 mm | \varnothing 1.6 x 19 mm | standard | 5 pieces | 0 502 248 | 4.67 € |
| | \varnothing 0.7 x 0.5 mm | \varnothing 1.6 x 19 mm | standard | 5 pieces | 0 502 258 | 4.56 € |
| | \varnothing 0.8 x 0.6 mm | \varnothing 1.6 x 19 mm | standard | 5 pieces | 0 502 259 | 4.68 € |
| | \varnothing 0.9 x 0.7 mm | \varnothing 1.6 x 19 mm | standard | 5 pieces | 0 502 342 | 4.56 € |
| | \varnothing 1.0 x 0.8 mm | \varnothing 1.6 x 19 mm | standard | 5 pieces | 0 502 253 | 4.56 € |
| | \varnothing 1.2 x 1.0 mm | \varnothing 1.6 x 19 mm | standard | 5 pieces | 0 502 343 | 4.56 € |
| | \varnothing 1.4 x 1.2 mm | \varnothing 1.6 x 19 mm | standard | 5 pieces | 0 502 256 | 4.56 € |
|  | | \varnothing 1.6 x 19 mm | fine, twisted | 5 pieces | 0 502 263 | 10.35 € |
|  | \varnothing 1.6 x 1.3 mm | \varnothing 1.6 x 19 mm | standard | 5 pieces | 0 502 201 | 4.56 € |
|  | | \varnothing 1.6 x 19 mm | fine, twisted | 5 pieces | 0 502 202 | 9.90 € |
|  | \varnothing 1.8 x 1.4 mm | \varnothing 1.6 x 19 mm | standard | 5 pieces | 0 502 254 | 4.56 € |
| | \varnothing 2.1 x 1.8 mm | \varnothing 1.6 x 19 mm | standard | 5 pieces | 0 502 344 | 4.56 € |
| | \varnothing 2.3 x 1.8 mm | \varnothing 1.6 x 19 mm | standard | 5 pieces | 0 502 255 | 4.56 € |
|  | | \varnothing 1.6 x 19 mm | fine, twisted | 5 pieces | 0 502 203 | 9.90 € |
| pointed cone | | | | | | |
|  | \varnothing 1.0 x 4.3 mm | \varnothing 1.6 x 19 mm | fine, twisted | 5 pieces | 0 502 307 | 8.30 € |
| | \varnothing 1.4 x 6.2 mm | \varnothing 1.6 x 19 mm | fine, twisted | 5 pieces | 0 502 303 | 8.30 € |
| pear | | | | | | |
|  | \varnothing 0.8 x 3.0 mm | \varnothing 1.6 x 19 mm | standard | 5 pieces | 0 502 376 | 4.56 € |
| | \varnothing 1.2 x 5.0 mm | \varnothing 1.6 x 19 mm | fine, twisted | 5 pieces | 0 502 391 | 8.30 € |
| flame | | | | | | |
|  | \varnothing 0.9 x 3.6 mm | \varnothing 1.6 x 19 mm | fine, straight | 5 pieces | 0 502 229 | 9.90 € |
| | \varnothing 1.0 x 4.5 mm | \varnothing 1.6 x 19 mm | fine, straight | 5 pieces | 0 502 261 | 8.50 € |
|  | \varnothing 1.2 x 3.5 mm | \varnothing 1.6 x 19 mm | fine, twisted | 5 pieces | 0 502 227 | 9.90 € |
| | \varnothing 1.2 x 3.7 mm | \varnothing 1.6 x 19 mm | fine, straight | 5 pieces | 0 502 262 | 10.10 € |
| | \varnothing 1.2 x 8.0 mm | \varnothing 1.6 x 19 mm | fine, twisted | 5 pieces | 0 502 275 | 10.10 € |
| | \varnothing 1.4 x 3.5 mm | \varnothing 1.6 x 19 mm | fine, twisted | 5 pieces | 0 502 233 | 9.90 € |
| | \varnothing 1.8 x 3.8 mm | \varnothing 1.6 x 19 mm | fine, twisted | 5 pieces | 0 502 230 | 10.00 € |
| football | | | | | | |
|  | \varnothing 1.2 x 3.1 mm | \varnothing 1.6 x 19 mm | fine, twisted | 5 pieces | 0 502 224 | 9.90 € |
| | \varnothing 1.4 x 3.1 mm | \varnothing 1.6 x 19 mm | fine, twisted | 5 pieces | 0 502 235 | 10.00 € |
| | \varnothing 1.8 x 3.5 mm | \varnothing 1.6 x 19 mm | fine, twisted | 5 pieces | 0 502 236 | 10.35 € |
| | \varnothing 2.3 x 4.2 mm | \varnothing 1.6 x 19 mm | fine, twisted | 5 pieces | 0 502 231 | 9.90 € |
| grenade | | | | | | |
|  | \varnothing 1.4 x 3.5 mm | \varnothing 1.6 x 19 mm | fine, twisted | 5 pieces | 0 502 266 | 10.35 € |
|  | \varnothing 1.6 x 3.5 mm | \varnothing 1.6 x 19 mm | fine, twisted | 5 pieces | 0 502 268 | 10.10 € |

Carbide milling cutters/finishers shank Ø 1,6 mm

| | Head dimensions | Shank Ø x total length | Cut | Packing quantity | Order No. | Price from 1 piece |
|---|-----------------|------------------------|----------------|------------------|--------------------|-----------------------|
| cone with safety point | | | | | | |
|  | Ø 1.4 x 6.0 mm | Ø 1.6 x 19 mm | fine, straight | 5 pieces | 0 502 220 | 9.90 € |
| | Ø 1.4 x 9.0 mm | Ø 1.6 x 19 mm | fine, straight | 5 pieces | 0 502 221 | 8.50 € |
| cone, round | | | | | | |
|  | Ø 1.0 x 4.2 mm | Ø 1.6 x 19 mm | standard | 5 pieces | 0 502 206 | 4.56 € |
| | Ø 1.2 x 4.1 mm | Ø 1.6 x 19 mm | standard | 5 pieces | 0 502 308 | 4.56 € |
| | Ø 1.6 x 4.1 mm | Ø 1.6 x 19 mm | standard | 5 pieces | 0 502 271 | 4.56 € |
| | Ø 1.8 x 8.0 mm | Ø 1.6 x 19 mm | fine, twisted | 5 pieces | 0 502 237 | 10.35 € |
| torpedo | | | | | | |
|  | Ø 1.0 x 6.0 mm | Ø 1.6 x 19 mm | fine, twisted | 5 pieces | 0 502 222 | 9.90 € |
| | Ø 1.2 x 8.0 mm | Ø 1.6 x 19 mm | fine, twisted | 5 pieces | 0 502 981 | 9.90 € |
| | Ø 1.4 x 10 mm | Ø 1.6 x 19 mm | fine, twisted | 5 pieces | 0 502 243 | 10.00 € |
| torpedo, conical | | | | | | |
|  | Ø 1,4 x 10 mm | Ø 1.6 x 19 mm | fine, twisted | 5 pieces | 0 502 986 | 10.45 € |
| | Ø 1.6 x 10 mm | Ø 1.6 x 19 mm | fine, twisted | 5 pieces | 0 502 245 | 10.35 € |
| cylinder, round | | | | | | |
|  | Ø 0.8 x 4.1 mm | Ø 1.6 x 19 mm | standard | 5 pieces | 0 502 924 | 4.56 € |
| | Ø 1.2 x 4.1 mm | Ø 1.6 x 19 mm | standard | 5 pieces | 0 502 926 | 4.56 € |
| | Ø 1.4 x 4.5 mm | Ø 1.6 x 19 mm | standard | 5 pieces | 0 502 204-1 | 7.40 € |

 *matching set*

| | Order No. | Price from 1 set |
|---|---------------------|----------------------------|
| Set of carbide milling cutters/finishers | | |
|  | contents: 12 pieces | 0 502 200-1 66.05 € |



The perfect complement

Rotating tool holders



| Order No. | Price |
|------------------|---------|
| 0 200 020 | 19.90 € |

Carbide milling cutters with titanium nitride coating

| | Head dimensions | Shank Ø x total length | Cut | Packing quantity | Order No. | Price from 1 piece |
|---|-----------------|------------------------|------------|------------------|------------------|-----------------------|
| Carbide milling cutters with titanium nitridecoating, shank Ø 1.6 mm | | | | | | |
| cylinder | | | | | | |
|  | Ø 1.0 x 4.2 mm | Ø 1.6 x 19 mm | double cut | 5 pieces | 0 502 211 | 7.50 € |
| | Ø 1.2 x 4.2 mm | Ø 1.6 x 19 mm | double cut | 5 pieces | 0 502 218 | 7.50 € |
| cone, round | | | | | | |
|  | | Ø 1.6 x 19 mm | double cut | 5 pieces | 0 502 214 | 7.50 € |
| cylinder, round | | | | | | |
|  | Ø 1.0 x 4.2 mm | Ø 1.6 x 19 mm | double cut | 5 pieces | 0 502 219 | 7.50 € |
| | Ø 1.2 x 4.2 mm | Ø 1.6 x 19 mm | double cut | 5 pieces | 0 502 213 | 7.50 € |

The perfect complement

High speed handpiece P 320

- max. speed 320,000 rpm
- ideal for all filigree tasks (deburring on steel, stainless steel, glass and plastics)
- compact, ergonomic shape
- rapid tool change



| Order No. | Price |
|--------------------|----------|
| 0 009 900-0 | 942.00 € |



Working Ø of the tool

Max. perm. speed





Recommended rpm

| | | |
|--------------|---------------|-------------------------|
| 0,7 – 1,0 mm | 450.000 1/min | 100.000 – 200.000 1/min |
| 1,2 – 1,4 mm | 450.000 1/min | 70.000 – 220.000 1/min |
| 1,6 – 1,8 mm | 450.000 1/min | 55.000 – 160.000 1/min |
| 2,1 – 2,3 mm | 300.000 1/min | 40.000 – 120.000 1/min |
| 2,5 – 2,7 mm | 160.000 1/min | 35.000 – 110.000 1/min |
| 2,9 – 3,1 mm | 140.000 1/min | 30.000 – 95.000 1/min |
| 3,3 – 4,0 mm | 120.000 1/min | 25.000 – 75.000 1/min |
| 4,2 – 5,0 mm | 95.000 1/min | 15.000 – 60.000 1/min |
| 5,5 – 7,0 mm | 60.000 1/min | 12.000 – 40.000 1/min |
| 8,0 – 10 mm | 45.000 1/min | 10.000 – 20.000 1/min |

Milling burs made of ceramic material

Shank-Ø 2,35 mm

The cutters made of high-performance ceramics are available in a cylindrical, round conical and tree shape. Each shape is available with coarse, medium and fine teeth. The cutters are characterised by a long service life, very good cutting properties, little heating, no smearing or clogging and very quiet running. Optimally suited for processing plastic, rubber, silicone, foam, plaster and acrylic, etc. Recommended speed range:

| | Head dimensions | Shank Ø x total length | Cut | Order No. | Price from | |
|---|-----------------|------------------------|--------------------|------------------|------------|----------|
| | | | | | 1 piece | 5 pieces |
| Milling burs made of ceramic, shank Ø 2.35 mm | | | | | | |
| cylinder | | | | | | |
|  | Ø 6 x 14 mm | Ø 2.35 x 52 mm | double cut, fine | 0 529 033 | 22.05 € | 18.90 € |
| | | Ø 2.35 x 52 mm | double cut, medium | 0 529 034 | 22.05 € | 18.90 € |
| | | Ø 2.35 x 52 mm | double cut, coarse | 0 529 035 | 22.05 € | 18.90 € |
| round cone | | | | | | |
|  | Ø 6 x 14 mm | Ø 2.35 x 52 mm | double cut, fine | 0 529 013 | 22.05 € | 18.90 € |
| | | Ø 2.35 x 52 mm | double cut, medium | 0 529 014 | 22.05 € | 18.90 € |
| | | Ø 2.35 x 52 mm | double cut, coarse | 0 529 015 | 22.05 € | 18.90 € |
| rounded arch | | | | | | |
|  | Ø 6 x 14 mm | Ø 2.35 x 52 mm | double cut, fine | 0 529 023 | 22.05 € | 18.90 € |
| | | Ø 2.35 x 52 mm | double cut, medium | 0 529 024 | 22.05 € | 18.90 € |
| | | Ø 2.35 x 52 mm | double cut, coarse | 0 529 025 | 22.05 € | 18.90 € |
| torpedo | | | | | | |
|  | Ø 2.3 x 13 mm | Ø 2.35 x 52 mm | double cut, fine | 0 529 043 | 22.05 € | 18.90 € |
| | | Ø 2.35 x 52 mm | double cut, medium | 0 529 044 | 22.05 € | 18.90 € |
| | | Ø 2.35 x 52 mm | double cut, coarse | 0 529 045 | 22.05 € | 18.90 € |

↓ *matching set*

| | Order No. | Price from | |
|---------------------------------------|-----------|------------------|---------|
| | | 1 set | |
| Set of ceramic milling cutters | | | |
| contents: | 3 pieces | 0 529 005 | 62.05 € |



Application: foam



Application: plastic





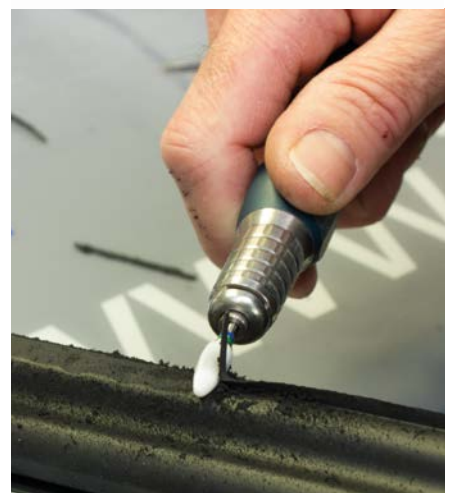

Application: rubber



Carbide milling cutters

shank Ø 2,35 mm

| | Head dimensions | Shank Ø x total length | Cut | Design | Order No. | Price from | | |
|---|-----------------|------------------------|--------|----------|------------------|------------|-----------|------------|
| | | | | | | 1 piece | 10 pieces | 100 pieces |
| Carbide milling cutters, shank Ø 2.35 mm | | | | | | | | |
| cylinder | | | | | | | | |
|  | Ø 1.0 x 4.1 mm | Ø 2.35 x 44.5 mm | normal | standard | 0 517 630 | 7.05 € | 5.85 € | 4.26 € |
| | Ø 1.4 x 4.5 mm | Ø 2.35 x 44.5 mm | normal | standard | 0 517 631 | 7.05 € | 5.85 € | 4.26 € |
| | Ø 1.6 x 4.5 mm | Ø 2.35 x 44.5 mm | normal | standard | 0 517 632 | 7.05 € | 5.85 € | 4.26 € |
|  | Ø 2.1 x 5.1 mm | Ø 2.35 x 44.5 mm | normal | standard | 0 517 633 | 7.05 € | 5.85 € | 4.26 € |
| | Ø 2.3 x 5.4 mm | Ø 2.35 x 44.5 mm | normal | standard | 0 517 634 | 7.05 € | 5.85 € | 4.26 € |
| sphere | | | | | | | | |
|  | Ø 0.9 x 0.75 mm | Ø 2.35 x 44.5 mm | normal | standard | 0 517 600 | 7.05 € | 5.85 € | 4.37 € |
| | Ø 1.0 x 0.8 mm | Ø 2.35 x 44.5 mm | normal | standard | 0 517 601 | 7.05 € | 5.85 € | 4.37 € |
| | Ø 1.2 x 1.0 mm | Ø 2.35 x 44.5 mm | normal | standard | 0 517 602 | 7.05 € | 5.85 € | 4.37 € |
| | Ø 1.4 x 1.2 mm | Ø 2.35 x 44.5 mm | normal | standard | 0 517 603 | 7.05 € | 5.85 € | 4.37 € |
|  | Ø 1.6 x 1.4 mm | Ø 2.35 x 44.5 mm | normal | standard | 0 517 604 | 7.05 € | 5.85 € | 4.37 € |
| | Ø 1.8 x 1.4 mm | Ø 2.35 x 44.5 mm | normal | standard | 0 517 605 | 7.05 € | 5.85 € | 4.37 € |
| | Ø 2.1 x 1.9 mm | Ø 2.35 x 44.5 mm | normal | standard | 0 517 606 | 7.05 € | 5.85 € | 4.37 € |



Conversion table – metres per minute (m/min) to revolutions per minute (rpm)

| m/min | Cutting edge diameter/ rotational speed (rpm) m/min | | | | | | | | |
|-------|---|--------|--------|--------|--------|--------|--------|--------|--------|
| | 2 mm | 3 mm | 6 mm | 10 mm | 12 mm | 16 mm | 18 mm | 20 mm | 25 mm |
| 100 | 15.920 | 10.600 | 5.300 | 3.180 | 2.650 | 1.990 | 1.770 | 1.540 | 1.270 |
| 150 | 23.880 | 15.910 | 7.950 | 4.770 | 3.980 | 2.980 | 2.650 | 2.390 | 1.910 |
| 200 | 31.850 | 21.210 | 10.600 | 6.360 | 5.300 | 3.980 | 3.530 | 3.180 | 2.540 |
| 250 | 39.800 | 26.250 | 13.260 | 7.950 | 6.630 | 4.970 | 4.420 | 3.980 | 3.180 |
| 300 | 47.770 | 31.820 | 15.910 | 9.550 | 7.950 | 5.970 | 5.300 | 4.770 | 3.820 |
| 350 | 55.730 | 37.130 | 18.560 | 11.140 | 9.280 | 6.960 | 6.190 | 5.570 | 4.450 |
| 400 | 63.700 | 42.430 | 21.210 | 12.730 | 10.610 | 7.960 | 7.070 | 6.360 | 5.090 |
| 450 | 71.650 | 47.740 | 23.820 | 14.320 | 11.930 | 8.950 | 7.960 | 7.160 | 5.730 |
| 500 | 79.600 | 53.040 | 26.520 | 15.910 | 13.260 | 9.940 | 8.840 | 7.950 | 6.360 |
| 550 | 87.580 | 58.350 | 29.170 | 17.500 | 14.590 | 10.940 | 9.720 | 8.750 | 7.000 |
| 600 | 95.540 | 63.650 | 31.820 | 19.090 | 15.910 | 11.930 | 10.610 | 9.550 | 7.640 |
| 650 | 103.500 | 69.000 | 34.500 | 20.700 | 17.250 | 12.940 | 11.500 | 10.350 | 8.280 |
| 700 | 111.460 | 74.300 | 37.150 | 22.300 | 18.570 | 13.930 | 12.380 | 11.150 | 8.900 |
| 750 | 119.420 | 79.600 | 39.800 | 23.880 | 19.900 | 14.930 | 13.270 | 11.950 | 9.550 |
| 800 | 127.380 | 84.900 | 42.460 | 25.470 | 21.230 | 15.920 | 14.150 | 12.740 | 10.190 |
| 850 | 135.350 | 90.200 | 45.110 | 27.070 | 22.560 | 16.920 | 15.040 | 13.540 | 10.830 |
| 900 | 143.310 | 95.540 | 47.770 | 28.660 | 23.880 | 17.910 | 15.920 | 14.330 | 11.460 |

Recommended cutting speeds:

hardened steels, non-hardened steels, cast steel
 stainless steels, titanium, high-alloy steels, nickel
 Aluminium, plastics, non-ferrous metals









V = 350 – 700 m/min
 V = 450 – 800 m/min
 V = 500 – 900 m/min

Milling cutters INOX shank Ø 3 mm

The INOX series milling burs have a specially developed geometry for the growing market demand for stainless steel processing.

These new cutters offer genuine advantages owing to their effective milling performance that allows high stock removal on all austenitic, rust- and acid-resistant steels. Up to 100% more cutting performance compared to conventional criss-cross teeth. In addition, the new cutter geometry allows the operator to work more efficiently by reducing heat generation (no annealing colours) at the interface between the cutting edge and the workpiece.



| | Head dimensions | Shank Ø x total length | Cut | Design | Order No. | Price from | | |
|---|-------------------|------------------------|------|----------|------------------|------------|----------|------------|
| | | | | | | 1 piece | 5 pieces | 100 pieces |
| Carbide milling cutters INOX, shank Ø 3 mm | | | | | | | | |
| cylinder | | | | | | | | |
|  | ☒ Ø 3 x 14 mm | Ø 3 x 38 mm | INOX | VHM | 0 528 003 | 9.90 € | 8.55 € | 6.55 € |
|  | ☒ Ø 6.3 x 12.7 mm | Ø 3 x 45 mm | INOX | Standard | 0 528 006 | 16.00 € | 13.80 € | 10.40 € |
| rounded cylinder | | | | | | | | |
|  | ☒ Ø 3 x 14 mm | Ø 3 x 38 mm | INOX | VHM | 0 528 023 | 9.90 € | 8.55 € | 6.55 € |
|  | ☒ Ø 6.3 x 12.7 mm | Ø 3 x 44 mm | INOX | Standard | 0 528 026 | 16.00 € | 13.80 € | 10.40 € |
| sphere | | | | | | | | |
|  | ☒ Ø 3 mm | Ø 3 x 38 mm | INOX | VHM | 0 528 043 | 9.90 € | 8.55 € | 6.55 € |
|  | ☒ Ø 6.3 mm | Ø 3 x 38 mm | INOX | Standard | 0 528 046 | 16.00 € | 13.80 € | 10.40 € |
| rounded arch | | | | | | | | |
|  | ☒ Ø 3 x 14 mm | Ø 3 x 38 mm | INOX | VHM | 0 528 063 | 9.90 € | 8.55 € | 6.55 € |
|  | ☒ Ø 6.3 x 12.7 mm | Ø 3 x 45 mm | INOX | Standard | 0 528 066 | 16.00 € | 13.80 € | 10.40 € |

 *matching set*

| | Order No. | Price from |
|---|--------------------|--------------------------|
| | | 1 set |
| Set of carbide milling cutters INOX | | |
|  | contents: 8 pieces | 0 528 000 87.80 € |



















Milling cutters for processing aluminium shank \varnothing 3 mm

Milling cutters for processing aluminium

Milling cutters with a coarse cut and a \varnothing 3 mm shank. For processing non-ferrous metals, aluminium, copper, brass and plastics. Optimally suited for milling work (deburring, welding seam processing, contours, etc.) in mould, machine and model building.

Cutting speed: 400 - 1.000 m/min



| | Head dimensions | Shank \varnothing x total length | Cut | Design | Order No. | Price from | | |
|--|-----------------------------------|------------------------------------|--------|-------------|------------------|------------|----------|------------|
| | | | | | | 1 piece | 5 pieces | 100 pieces |
| Milling cutters for processing aluminium, shank \varnothing 3 mm | | | | | | | | |
| cylinder | | | | | | | | |
|  | \varnothing 3 x 14 mm | \varnothing 3 x 38 mm | coarse | solid carb. | 0 526 061 | 9.25 € | 8.10 € | 6.20 € |
|  | \varnothing 6.3 x 12.7 mm | \varnothing 3 x 38 mm | coarse | standard | 0 526 062 | 15.25 € | 13.05 € | 10.00 € |
| rounded cylinder | | | | | | | | |
|  | \varnothing 3 x 14 mm | \varnothing 3 x 38 mm | coarse | solid carb. | 0 526 065 | 9.25 € | 8.10 € | 6.20 € |
|  | \varnothing 6.3 x 12.7 mm | \varnothing 3 x 38 mm | coarse | standard | 0 526 066 | 15.25 € | 13.05 € | 10.00 € |
| sphere | | | | | | | | |
|  | \varnothing 3 mm | \varnothing 3 x 38 mm | coarse | solid carb. | 0 526 067 | 9.25 € | 8.10 € | 6.20 € |
|  | \varnothing 4 mm | \varnothing 3 x 38 mm | coarse | solid carb. | 0 526 068 | 21.85 € | 18.90 € | 14.50 € |
|  | \varnothing 6.3 mm | \varnothing 3 x 38 mm | coarse | standard | 0 526 069 | 15.25 € | 13.05 € | 10.00 € |
| round cone | | | | | | | | |
|  | \varnothing 3 x 14 mm / 8° | \varnothing 3 x 38 mm | coarse | solid carb. | 0 526 076 | 9.35 € | 8.00 € | 6.10 € |
|  | \varnothing 6.3 x 15.8 mm / 22° | \varnothing 3 x 38 mm | coarse | standard | 0 526 077 | 15.25 € | 13.05 € | 10.00 € |
| pointed cone | | | | | | | | |
|  | \varnothing 3 x 11 mm / 14° | \varnothing 3 x 38 mm | coarse | solid carb. | 0 526 078 | 9.35 € | 8.00 € | 6.10 € |
|  | \varnothing 6.3 x 12.7 mm / 22° | \varnothing 3 x 38 mm | coarse | standard | 0 526 079 | 15.25 € | 13.05 € | 10.00 € |
| rounded arch | | | | | | | | |
|  | \varnothing 3 x 14 mm | \varnothing 3 x 38 mm | coarse | solid carb. | 0 526 072 | 8.95 € | 7.90 € | 6.10 € |
|  | \varnothing 6.3 x 12.7 mm | \varnothing 3 x 38 mm | coarse | standard | 0 526 073 | 15.25 € | 13.05 € | 10.00 € |
| tree with pointed end | | | | | | | | |
|  | \varnothing 3 x 14 mm | \varnothing 3 x 38 mm | coarse | solid carb. | 0 526 074 | 9.25 € | 8.00 € | 6.10 € |
|  | \varnothing 6.3 x 12.7 mm | \varnothing 3 x 38 mm | coarse | standard | 0 526 075 | 15.25 € | 13.05 € | 10.00 € |
| drop | | | | | | | | |
|  | \varnothing 3 x 6 mm | \varnothing 3 x 38 mm | coarse | solid carb. | 0 526 070 | 9.25 € | 8.10 € | 6.20 € |
|  | \varnothing 6.3 x 9.5 mm | \varnothing 3 x 38 mm | coarse | standard | 0 526 071 | 15.25 € | 13.05 € | 10.00 € |
| cylinder – end mill | | | | | | | | |
|  | \varnothing 3 x 14 mm | \varnothing 3 x 38 mm | coarse | solid carb. | 0 526 063 | 10.30 € | 8.75 € | 6.75 € |
|  | \varnothing 6.3 x 12.7 mm | \varnothing 3 x 38 mm | coarse | standard | 0 526 064 | 16.40 € | 14.20 € | 10.95 € |

matching set









| Order No. | Price from | |
|--|------------|------------------|
| | 1 set | 5 set |
| Set of milling cutters for processing aluminium | | |
| contents: | 8 pieces | 0 526 080 |
| | | 72.90 € |
| | | 60.90 € |





Carbide milling cutters shank Ø 3 mm

| | Head dimensions | Type | Shank Ø x total length | Cut | Design | Order No. | Price from | | |
|--|-----------------|------|------------------------|------------|-------------|------------------|------------|----------|------------|
| | | | | | | | 1 piece | 5 pieces | 100 pieces |
| Carbide milling cutters, shank Ø 3 mm | | | | | | | | | |
| cylinder | | | | | | | | | |
| | Ø 1 x 3.9 mm | | Ø 3 x 45 mm | normal | standard | 0 517 423 | 10.45 € | 8.60 € | 7.05 € |
| | Ø 1 x 4 mm | | Ø 3 x 38 mm | normal | solid carb. | 0 517 356 | 15.25 € | 11.15 € | 8.30 € |
| | Ø 1.5 x 4 mm | | Ø 3 x 38 mm | normal | solid carb. | 0 517 357 | 15.25 € | 11.15 € | 8.30 € |
| | Ø 1.5 x 6 mm | | Ø 3 x 38 mm | double cut | solid carb. | 0 501 441 | 7.40 € | 5.20 € | 4.46 € |
| | | | Ø 3 x 38 mm | fine | solid carb. | 0 501 346 | 9.35 € | 8.30 € | 6.45 € |
| | Ø 2 x 4 mm | | Ø 3 x 38 mm | normal | solid carb. | 0 517 358 | 15.25 € | 11.15 € | 8.30 € |
| | Ø 2.1 x 5.1 mm | | Ø 3 x 45 mm | normal | standard | 0 517 428 | 10.75 € | 8.85 € | 7.25 € |
| | Ø 2.5 x 11 mm | | Ø 3 x 38 mm | double cut | solid carb. | 0 501 442 | 11.35 € | 7.80 € | 5.80 € |
| | | | Ø 3 x 38 mm | fine | solid carb. | 0 501 345 | 9.35 € | 8.30 € | 6.45 € |
| | Ø 3 x 12 mm | | Ø 3 x 38 mm | diamond | solid carb. | 0 501 102 | 13.45 € | 9.05 € | 6.95 € |
| | Ø 3 x 12.7 mm | | Ø 3 x 38 mm | fine | solid carb. | 0 501 347 | 9.35 € | 8.20 € | 6.45 € |
| | Ø 3 x 14 mm | | Ø 3 x 38 mm | double cut | solid carb. | 0 501 443 | 7.40 € | 5.20 € | 4.46 € |
| | | | Ø 3 x 38 mm | normal | solid carb. | 0 503 097 | 11.70 € | 8.00 € | 6.30 € |
| | | | Ø 3 x 38 mm | special-G | solid carb. | 0 501 401 | 11.35 € | 7.80 € | 5.90 € |
| | | | Ø 3 x 50 mm | double cut | solid carb. | 0 501 453 | 15.55 € | 10.75 € | 8.00 € |
| | | | Ø 3 x 75 mm | double cut | solid carb. | 0 501 463 | 17.75 € | 12.50 € | 9.15 € |
| | Ø 4 x 10.7 mm | | Ø 3 x 45 mm | normal | standard | 0 517 432 | 16.00 € | 13.55 € | 11.70 € |
| | Ø 5 x 12.7 mm | | Ø 3 x 38 mm | double cut | solid carb. | 0 501 552 | 20.20 € | 16.40 € | 12.40 € |
| | Ø 6.3 x 12.7 mm | | Ø 3 x 50 mm | double cut | standard | 0 501 551 | 18.60 € | 12.95 € | 9.70 € |
| cylinder – end mill | | | | | | | | | |
| | Ø 1.5 x 6 mm | | Ø 3 x 38 mm | double cut | solid carb. | 0 501 446 | 11.35 € | 7.80 € | 5.80 € |
| | | | Ø 3 x 38 mm | normal | solid carb. | 0 503 201 | 11.70 € | 8.00 € | 6.30 € |
| | Ø 1.5 x 6 mm | | Ø 3 x 50 mm | double cut | solid carb. | 0 501 800 | 16.00 € | 11.05 € | 8.20 € |
| | | | Ø 3 x 75 mm | double cut | solid carb. | 0 501 801 | 17.75 € | 12.50 € | 9.15 € |
| | Ø 1.6 x 5 mm | | Ø 3 x 38 mm | diamond | solid carb. | 0 501 110 | 15.80 € | 10.85 € | 8.10 € |
| | | | Ø 3 x 40 mm | fine | solid carb. | 0 501 341 | 11.55 € | 10.10 € | 7.55 € |
| | Ø 2.4 x 9.5 mm | | Ø 3 x 38 mm | diamond | solid carb. | 0 501 111 | 15.35 € | 10.50 € | 7.90 € |
| | | | Ø 3 x 38 mm | double cut | solid carb. | 0 501 445 | 7.40 € | 5.20 € | 4.46 € |
| | Ø 2.5 x 11 mm | | Ø 3 x 38 mm | fine | solid carb. | 0 501 348 | 9.35 € | 8.20 € | 6.45 € |
| | | | Ø 3 x 50 mm | double cut | solid carb. | 0 501 802 | 16.00 € | 11.05 € | 8.20 € |
| | Ø 3 mm | | Ø 3 x 38 mm | normal | solid carb. | 0 502 441 | 11.70 € | 8.00 € | 6.00 € |
| | | | | | | | | | |
| | Ø 3 x 12 mm | | Ø 3 x 38 mm | diamond | solid carb. | 0 501 112 | 15.25 € | 10.40 € | 7.80 € |
| | | | Ø 3 x 14 mm | double cut | solid carb. | 0 501 444 | 7.40 € | 5.20 € | 4.46 € |
| | Ø 3 x 14 mm | | Ø 3 x 38 mm | normal | solid carb. | 0 503 203 | 11.70 € | 8.00 € | 6.30 € |
| | | | Ø 3 x 38 mm | special-G | solid carb. | 0 501 406 | 11.35 € | 7.80 € | 5.90 € |
| | Ø 3 x 14 mm | | Ø 3 x 43 mm | fine | solid carb. | 0 501 342 | 9.35 € | 8.30 € | 6.45 € |
| | | | Ø 3 x 50 mm | double cut | solid carb. | 0 501 804 | 15.55 € | 10.75 € | 8.00 € |
| | Ø 3 x 14 mm | | Ø 3 x 50 mm | normal | solid carb. | 0 503 047 | 16.00 € | 11.05 € | 8.55 € |
| | | | Ø 3 x 75 mm | double cut | solid carb. | 0 501 805 | 20.40 € | 14.20 € | 10.65 € |
| | Ø 6 x 7 mm | | Ø 3 x 37 mm | fine | standard | 0 501 343 | 20.75 € | 17.85 € | 13.45 € |
| | | | Ø 3 x 43 mm | fine | standard | 0 501 344 | 22.45 € | 19.70 € | 14.65 € |
| | Ø 6.3 x 4.7 mm | | Ø 3 x 43 mm | double cut | standard | 0 502 551 | 18.60 € | 12.95 € | 9.70 € |











Carbide milling cutters shank \varnothing 3 mm

| | Head dimensions | Type | Shank \varnothing x total length | Cut | Design | Order No. | Price from | | |
|---|---|--------------------------|---------------------------------------|-------------------------|------------------|------------------|------------------|----------|------------|
| | | | | | | | 1 piece | 5 pieces | 100 pieces |
| rounded cylinder | | | | | | | | | |
|  | \varnothing 1 x 4 mm | | \varnothing 3 x 38 mm | normal | solid carb. | 0 517 348 | 15.25 € | 11.15 € | 8.30 € |
| | \varnothing 1.5 x 4 mm | | \varnothing 3 x 38 mm | normal | solid carb. | 0 517 349 | 15.25 € | 11.15 € | 8.30 € |
|  | \varnothing 2 x 4 mm | | \varnothing 3 x 38 mm | normal | solid carb. | 0 517 360 | 15.25 € | 11.15 € | 8.30 € |
| | \varnothing 2 x 10 mm | | \varnothing 3 x 40 mm | fine | solid carb. | 0 501 331 | 10.75 € | 9.40 € | 7.15 € |
| | \varnothing 2.5 x 11 mm | | \varnothing 3 x 38 mm | special-G | solid carb. | 0 501 411 | 11.35 € | 7.80 € | 5.90 € |
| | | | \varnothing 3 x 38 mm | double cut | solid carb. | 0 503 441 | 7.40 € | 5.20 € | 4.46 € |
| | | | \varnothing 3 x 38 mm | fine | solid carb. | 0 501 334 | 9.35 € | 8.30 € | 6.45 € |
| | \varnothing 3 x 14 mm | | \varnothing 3 x 38 mm | double cut | solid carb. | 0 503 442 | 7.40 € | 5.20 € | 4.46 € |
| | | | \varnothing 3 x 38 mm | normal | solid carb. | 0 503 205 | 11.70 € | 8.00 € | 6.30 € |
| | | | \varnothing 3 x 38 mm | fine | solid carb. | 0 501 332 | 9.35 € | 8.20 € | 6.45 € |
| | | | \varnothing 3 x 38 mm | special-G | solid carb. | 0 501 412 | 11.35 € | 7.80 € | 5.90 € |
| | | | \varnothing 3 x 50 mm | double cut | solid carb. | 0 503 452 | 16.00 € | 11.05 € | 8.55 € |
|  | \varnothing 3 x 75 mm | | \varnothing 3 x 75 mm | double cut | solid carb. | 0 503 462 | 17.75 € | 12.50 € | 9.70 € |
| | \varnothing 4 x 12.7 mm | | \varnothing 3 x 38 mm | double cut | standard | 0 503 553 | 20.20 € | 16.40 € | 12.40 € |
| | | | \varnothing 3 x 38 mm | normal | standard | 0 503 214 | 20.20 € | 16.40 € | 12.75 € |
| | \varnothing 5 x 12.7 mm | | \varnothing 3 x 38 mm | double cut | solid carb. | 0 503 552 | 20.20 € | 16.40 € | 12.40 € |
| | \varnothing 6 x 13 mm | | \varnothing 3 x 43 mm | fine | standard | 0 501 333 | 17.95 € | 15.80 € | 11.90 € |
| | \varnothing 6.3 x 12.7 mm | | \varnothing 3 x 50 mm | double cut | standard | 0 503 551 | 13.15 € | 10.00 € | 7.50 € |
| | | | \varnothing 3 x 50 mm | normal | standard | 0 503 102 | 18.60 € | 12.95 € | 10.20 € |
| | | | | | | | | | |
| | | | | | | | | | |
| | | | | | | | | | |
| sphere | | | | | | | | | |
|  | \varnothing 0.9 x 0.75 mm | | \varnothing 3 x 45 mm | normal | standard | 0 517 121 | 9.70 € | 8.00 € | 6.55 € |
| | \varnothing 1 x 0.8 mm | | \varnothing 3 x 38 mm | normal | solid carb. | 0 517 354 | 15.25 € | 11.15 € | 8.30 € |
| | | | \varnothing 3 x 45 mm | normal | standard | 0 517 122 | 9.70 € | 8.00 € | 6.55 € |
| | \varnothing 1.2 x 1 mm | | \varnothing 3 x 45 mm | normal | standard | 0 517 123 | 9.45 € | 8.10 € | 6.60 € |
| | \varnothing 1.4 x 1.2 mm | | \varnothing 3 x 45 mm | normal | standard | 0 517 124 | 9.70 € | 8.00 € | 6.55 € |
| | \varnothing 1.5 x 1.3 mm | | \varnothing 3 x 38 mm | normal | solid carb. | 0 517 355 | 15.25 € | 11.15 € | 8.30 € |
| | \varnothing 1.6 x 1.4 mm | | \varnothing 3 x 45 mm | normal | standard | 0 517 125 | 9.70 € | 8.00 € | 6.55 € |
| | \varnothing 1.8 x 1.6 mm | | \varnothing 3 x 45 mm | normal | standard | 0 517 126 | 9.70 € | 8.00 € | 6.55 € |
| | \varnothing 2 x 1.7 mm | | \varnothing 3 x 38 mm | normal | solid carb. | 0 517 352 | 15.25 € | 11.15 € | 8.30 € |
| | \varnothing 2.1 x 1.9 mm | | \varnothing 3 x 45 mm | normal | standard | 0 517 127 | 9.45 € | 8.00 € | 6.60 € |
| | \varnothing 2.5 x 2.3 mm | | \varnothing 3 x 38 mm | double cut | solid carb. | 0 507 441 | 7.40 € | 5.20 € | 4.46 € |
| | | | \varnothing 3 x 38 mm | fine | solid carb. | 0 501 304 | 9.35 € | 8.20 € | 6.30 € |
| | | | \varnothing 3 x 45 mm | normal | standard | 0 517 129 | 16.00 € | 13.55 € | 11.20 € |
| |  | \varnothing 3 x 2.5 mm | | \varnothing 3 x 38 mm | double cut | solid carb. | 0 507 442 | 7.15 € | 5.05 € |
| | | | \varnothing 3 x 38 mm | normal | solid carb. | 0 503 211 | 11.70 € | 8.00 € | 6.30 € |
| | | | \varnothing 3 x 38 mm | fine | solid carb. | 0 501 301 | 9.35 € | 8.20 € | 6.30 € |
| | | | \varnothing 3 x 38 mm | special-G | solid carb. | 0 501 416 | 11.35 € | 7.80 € | 5.90 € |
| | | | \varnothing 3 x 50 mm | double cut | solid carb. | 0 507 452 | 16.00 € | 11.05 € | 8.55 € |
| | | | \varnothing 3 x 75 mm | double cut | solid carb. | 0 507 462 | 17.75 € | 12.50 € | 9.70 € |
| \varnothing 3.1 x 2.6 mm | | \varnothing 3 x 45 mm | normal | standard | 0 517 130 | 25.15 € | 21.05 € | 17.25 € | |
| \varnothing 4 x 3 mm | | \varnothing 3 x 34 mm | fine | solid carb. | 0 501 302 | 16.40 € | 14.70 € | 11.00 € | |
|  | \varnothing 4 x 3.5 mm | | \varnothing 3 x 45 mm | normal | standard | 0 517 131 | 25.15 € | 21.05 € | 17.25 € |
| | \varnothing 4 x 3.7 mm | | \varnothing 3 x 38 mm | double cut | standard | 0 507 443 | 27.75 € | 19.85 € | 14.95 € |
| | \varnothing 5 x 4.5 mm | | \varnothing 3 x 38 mm | double cut | solid carb. | 0 507 552 | 20.20 € | 16.40 € | 12.40 € |
| | | | \varnothing 3 x 45 mm | normal | standard | 0 517 132 | 25.15 € | 21.05 € | 17.25 € |
| | \varnothing 6 x 5 mm | | \varnothing 3 x 35 mm | fine | standard | 0 501 303 | 15.20 € | 13.20 € | 10.00 € |
| | \varnothing 6.3 x 5 mm | | \varnothing 3 x 44 mm | double cut | standard | 0 507 551 | 13.15 € | 10.00 € | 7.50 € |
| | | \varnothing 3 x 44 mm | normal | standard | 0 503 103 | 18.60 € | 12.95 € | 10.20 € | |





Carbide milling cutters shank Ø 3 mm

| | Head dimensions | Type | Shank Ø x total length | Cut | Design | Order No. | Price from | | | |
|---|-----------------------|-----------------------|------------------------|-------------|-------------|------------------|------------------|----------|------------|---------|
| | | | | | | | 1 piece | 5 pieces | 100 pieces | |
| tree with pointed end | | | | | | | | | | |
|  | Ø 1.5 x 4 mm | | Ø 3 x 38 mm | normal | solid carb. | 0 517 350 | 15.25 € | 11.15 € | 8.30 € | |
|  | Ø 3 x 6 mm | | Ø 3 x 38 mm | double cut | solid carb. | 0 505 441 | 7.40 € | 5.20 € | 4.46 € | |
| | | | Ø 3 x 38 mm | fine | solid carb. | 0 501 351 | 9.35 € | 8.30 € | 6.45 € | |
| | Ø 3 x 8 mm | | Ø 3 x 38 mm | special-G | solid carb. | 0 501 431 | 11.35 € | 7.80 € | 5.90 € | |
| | Ø 3 x 9.5 mm | | Ø 3 x 38 mm | double cut | solid carb. | 0 505 443 | 7.40 € | 5.20 € | 4.46 € | |
| | | | Ø 3 x 38 mm | fine | solid carb. | 0 501 352 | 9.35 € | 8.30 € | 6.45 € | |
| | Ø 3 x 12 mm | cut to centre | Ø 3 x 38 mm | double cut | solid carb. | 0 505 444 | 16.10 € | 11.25 € | 8.40 € | |
| | Ø 3 x 12.7 mm | | Ø 3 x 38 mm | fine | solid carb. | 0 501 353 | 9.35 € | 8.30 € | 6.45 € | |
| | | | Ø 3 x 38 mm | special-G | solid carb. | 0 501 432 | 11.35 € | 7.80 € | 5.90 € | |
| | | cut to centre | Ø 3 x 50 mm | double cut | solid carb. | 0 505 454 | 16.00 € | 12.40 € | 9.35 € | |
| | Ø 3 x 13 mm | | Ø 3 x 75 mm | double cut | solid carb. | 0 505 464 | 17.75 € | 12.50 € | 9.70 € | |
| | | extra slim tree shape | Ø 3 x 40 mm | fine | solid carb. | 0 501 354 | 13.35 € | 10.80 € | 7.30 € | |
|  | Ø 5 x 12.7 mm | | Ø 3 x 38 mm | double cut | solid carb. | 0 505 552 | 20.20 € | 16.40 € | 12.40 € | |
| | Ø 6.3 x 12.7 mm | | Ø 3 x 50 mm | double cut | standard | 0 505 551 | 13.15 € | 10.00 € | 7.50 € | |
| | | | | Ø 3 x 50 mm | normal | standard | 0 503 105 | 18.60 € | 12.95 € | 10.20 € |
| pointed cone | | | | | | | | | | |
|  | Ø 1.5 x 4 mm / 16° | | Ø 3 x 38 mm | normal | solid carb. | 0 517 351 | 15.25 € | 11.15 € | 8.30 € | |
|  | Ø 3 x 7 mm / 24° | cut to centre | Ø 3 x 30 mm | fine | solid carb. | 0 501 321 | 11.45 € | 9.20 € | 6.95 € | |
| | | | Ø 3 x 38 mm | double cut | solid carb. | 0 508 441 | 7.40 € | 5.20 € | 4.46 € | |
| | Ø 3 x 9 mm / 12° | | Ø 3 x 38 mm | normal | solid carb. | 0 503 290 | 11.70 € | 8.00 € | 6.30 € | |
| | | | Ø 3 x 38 mm | fine | solid carb. | 0 501 324 | 9.35 € | 8.30 € | 6.30 € | |
| | | cut to centre | Ø 3 x 38 mm | double cut | solid carb. | 0 508 442 | 15.25 € | 10.50 € | 7.80 € | |
| | Ø 3 x 11 mm / 14° | | Ø 3 x 38 mm | double cut | solid carb. | 0 508 445 | 7.40 € | 5.20 € | 4.46 € | |
| | | | Ø 3 x 38 mm | normal | solid carb. | 0 503 291 | 11.70 € | 8.00 € | 6.30 € | |
| | | | Ø 3 x 38 mm | fine | solid carb. | 0 501 322 | 9.35 € | 8.30 € | 6.30 € | |
| | | | Ø 3 x 38 mm | special-G | solid carb. | 0 501 436 | 11.35 € | 7.80 € | 5.90 € | |
| | | cut to centre | Ø 3 x 50 mm | double cut | solid carb. | 0 508 452 | 18.90 € | 15.65 € | 12.30 € | |
| | | | Ø 3 x 50 mm | normal | solid carb. | 0 503 298 | 16.00 € | 11.05 € | 8.55 € | |
| | | | Ø 3 x 75 mm | double cut | solid carb. | 0 508 462 | 17.75 € | 12.50 € | 9.70 € | |
| | Ø 3 x 16 mm / 7° | cut to centre | Ø 3 x 38 mm | double cut | solid carb. | 0 508 443 | 21.65 € | 15.15 € | 11.35 € | |
| | | | Ø 3 x 38 mm | double cut | solid carb. | 0 508 444 | 7.40 € | 5.20 € | 4.46 € | |
| | | | Ø 3 x 38 mm | normal | solid carb. | 0 503 209 | 11.70 € | 8.00 € | 6.30 € | |
| | | | Ø 3 x 38 mm | fine | solid carb. | 0 501 325 | 9.35 € | 8.30 € | 6.30 € | |
| | | | Ø 3 x 38 mm | special-G | solid carb. | 0 501 437 | 11.35 € | 7.80 € | 5.90 € | |
| | | Ø 5 x 12.7 mm / 16° | | Ø 3 x 38 mm | double cut | solid carb. | 0 508 552 | 20.20 € | 16.40 € | 12.40 € |
| | | | | Ø 3 x 38 mm | normal | solid carb. | 0 503 292 | 20.20 € | 16.40 € | 12.40 € |
| | Ø 6 x 13 mm / 26° | | Ø 3 x 43 mm | fine | standard | 0 501 323 | 21.85 € | 19.20 € | 14.25 € | |
| | Ø 6.3 x 12.7 mm / 22° | | Ø 3 x 54 mm | double cut | standard | 0 508 551 | 13.15 € | 10.00 € | 8.00 € | |





Carbide milling cutters shank \varnothing 3 mm

| | Head dimensions | Type | Shank \varnothing x total length | Cut | Design | Order No. | Price from | | | |
|---|---------------------------------|------------------------|---------------------------------------|-------------------------|-------------|------------------|------------------|----------|------------|--------|
| | | | | | | | 1 piece | 5 pieces | 100 pieces | |
| countersunk 60° | | | | | | | | | | |
|  | \varnothing 3 x 2.6 mm / 60° | teething on both sides | \varnothing 3 x 38 mm | fine | solid carb. | 0 501 328 | 13.35 € | 9.35 € | 7.15 € | |
| | | | \varnothing 3 x 38 mm | double cut | solid carb. | 0 511 442 | 11.90 € | 8.30 € | 6.30 € | |
|  | \varnothing 5 x 4.3 mm / 60° | | \varnothing 3 x 37 mm | fine | standard | 0 501 382 | 23.00 € | 20.75 € | 16.65 € | |
| countersunk 90° | | | | | | | | | | |
|  | \varnothing 3 x 1.5 mm / 90° | teething on both sides | \varnothing 3 x 38 mm | fine | solid carb. | 0 501 327 | 13.45 € | 9.35 € | 7.15 € | |
| | | | \varnothing 3 x 38 mm | double cut | solid carb. | 0 510 442 | 14.85 € | 10.30 € | 7.40 € | |
|  | \varnothing 4 x 2 mm / 90° | | \varnothing 3 x 34 mm | fine | solid carb. | 0 501 384 | 20.30 € | 18.35 € | 14.80 € | |
| | \varnothing 5 x 2.5 mm / 90° | | \varnothing 3 x 35 mm | fine | standard | 0 501 385 | 21.85 € | 19.80 € | 15.90 € | |
| | \varnothing 6 x 3 mm / 90° | | \varnothing 3 x 36 mm | fine | standard | 0 501 386 | 23.50 € | 21.75 € | 16.20 € | |
| round cone | | | | | | | | | | |
|  | \varnothing 3 x 9.5 mm / 8° | | \varnothing 3 x 38 mm | double cut | solid carb. | 0 509 441 | 11.70 € | 8.00 € | 6.30 € | |
| | | | \varnothing 3 x 38 mm | normal | solid carb. | 0 503 277 | 11.70 € | 8.00 € | 6.30 € | |
| | | | \varnothing 3 x 38 mm | fine | solid carb. | 0 501 361 | 9.25 € | 8.30 € | 6.45 € | |
| | \varnothing 3 x 12.7 mm / 8° | | | \varnothing 3 x 38 mm | double cut | solid carb. | 0 509 442 | 11.70 € | 8.00 € | 6.30 € |
| | | | | \varnothing 3 x 38 mm | normal | solid carb. | 0 503 208 | 11.70 € | 8.00 € | 6.30 € |
| | | | | \varnothing 3 x 38 mm | fine | solid carb. | 0 501 362 | 9.35 € | 8.20 € | 6.45 € |
| | | | | \varnothing 3 x 50 mm | double cut | solid carb. | 0 509 452 | 16.00 € | 11.05 € | 8.55 € |
|  | \varnothing 5 x 12.7 mm / 14° | | \varnothing 3 x 38 mm | double cut | solid carb. | 0 509 443 | 20.20 € | 16.40 € | 12.40 € | |
| | | | \varnothing 3 x 38 mm | normal | solid carb. | 0 503 278 | 20.20 € | 16.40 € | 12.40 € | |
| trapeze | | | | | | | | | | |
|  | \varnothing 2.5 x 3 mm / 10° | | \varnothing 3 x 38 mm | double cut | solid carb. | 0 513 441 | 11.70 € | 8.00 € | 6.30 € | |
| | | | \varnothing 3 x 38 mm | normal | solid carb. | 0 503 301 | 11.70 € | 8.00 € | 6.30 € | |
| | | | \varnothing 3 x 38 mm | fine | solid carb. | 0 501 371 | 9.35 € | 8.30 € | 6.45 € | |
|  | \varnothing 3 x 4 mm / 10° | | \varnothing 3 x 38 mm | double cut | solid carb. | 0 513 442 | 7.40 € | 5.20 € | 4.46 € | |
| | | | \varnothing 3 x 38 mm | fine | solid carb. | 0 501 372 | 9.35 € | 8.20 € | 6.45 € | |
| | \varnothing 3 x 7 mm / 10° | end cut | \varnothing 3 x 40 mm | double cut | solid carb. | 0 513 443 | 18.50 € | 15.80 € | 11.90 € | |
| | | | \varnothing 5 x 6.3 mm / 10° | double cut | solid carb. | 0 513 552 | 28.90 € | 20.30 € | 14.95 € | |
| | | | \varnothing 6.3 x 6 mm / 10° | double cut | standard | 0 513 551 | 18.60 € | 12.95 € | 10.20 € | |
| drop | | | | | | | | | | |
|  | \varnothing 1.5 x 4 mm | | \varnothing 3 x 38 mm | normal | solid carb. | 0 517 362 | 15.25 € | 11.15 € | 8.30 € | |
| | | | \varnothing 3 x 5.5 mm | \varnothing 3 x 38 mm | double cut | solid carb. | 0 506 441 | 11.70 € | 8.00 € | 6.30 € |
| | | | | \varnothing 3 x 38 mm | normal | solid carb. | 0 503 206 | 11.45 € | 7.85 € | 6.20 € |
| | | | | \varnothing 3 x 38 mm | fine | solid carb. | 0 501 356 | 9.35 € | 8.30 € | 6.45 € |
| | | | | \varnothing 3 x 38 mm | special-G | solid carb. | 0 501 421 | 11.35 € | 7.80 € | 5.90 € |
| | | | | \varnothing 3 x 50 mm | double cut | solid carb. | 0 506 451 | 16.00 € | 11.05 € | 8.55 € |
|  | \varnothing 5 x 7.1 mm | | \varnothing 3 x 75 mm | double cut | solid carb. | 0 506 461 | 17.75 € | 12.50 € | 9.70 € | |
| | | | \varnothing 3 x 38 mm | double cut | solid carb. | 0 506 552 | 20.20 € | 16.40 € | 12.40 € | |
| | | | \varnothing 6.3 x 9.5 mm | double cut | standard | 0 506 551 | 18.60 € | 12.95 € | 10.20 € | |













Carbide milling cutters shank Ø 3 mm

| | Head dimensions | Type | Shank Ø x total length | Cut | Design | Order No. | Price from | | |
|--|-----------------|------|------------------------|------------|-------------|------------------|------------|----------|------------|
| | | | | | | | 1 piece | 5 pieces | 100 pieces |
| flame | | | | | | | | | |
|  | Ø 3 x 6.3 mm | | Ø 3 x 38 mm | double cut | solid carb. | 0 512 441 | 7.40 € | 5.20 € | 4.46 € |
| | | | Ø 3 x 38 mm | normal | solid carb. | 0 503 022 | 11.70 € | 8.00 € | 6.00 € |
| | | | Ø 3 x 50 mm | double cut | solid carb. | 0 512 451 | 16.00 € | 11.05 € | 8.55 € |
| | | | Ø 3 x 75 mm | double cut | solid carb. | 0 512 461 | 17.75 € | 12.50 € | 9.70 € |
|  | Ø 5 x 9.5 mm | | Ø 3 x 38 mm | double cut | solid carb. | 0 512 442 | 20.30 € | 16.40 € | 12.40 € |
| rounded arch | | | | | | | | | |
|  | Ø 1.5 x 4 mm | | Ø 3 x 40 mm | normal | solid carb. | 0 517 361 | 15.25 € | 11.15 € | 8.30 € |
|  | Ø 3 x 6 mm | | Ø 3 x 38 mm | double cut | solid carb. | 0 504 441 | 7.40 € | 5.20 € | 4.46 € |
| | | | Ø 3 x 38 mm | fine | solid carb. | 0 501 311 | 9.35 € | 8.20 € | 6.30 € |
| | | | Ø 3 x 38 mm | double cut | solid carb. | 0 504 442 | 7.40 € | 5.20 € | 4.46 € |
| | | | Ø 3 x 38 mm | fine | solid carb. | 0 501 312 | 9.15 € | 8.10 € | 6.20 € |
| | | | Ø 3 x 38 mm | special-G | solid carb. | 0 501 426 | 11.35 € | 7.80 € | 5.90 € |
| | | | Ø 3 x 50 mm | double cut | solid carb. | 0 504 452 | 16.00 € | 11.05 € | 8.20 € |
| | | | Ø 3 x 75 mm | double cut | solid carb. | 0 504 462 | 17.75 € | 12.50 € | 9.15 € |
|  | Ø 5 x 12.7 mm | | Ø 3 x 38 mm | double cut | solid carb. | 0 504 552 | 20.20 € | 16.40 € | 12.40 € |
| | | | Ø 6 x 13 mm | fine | standard | 0 501 313 | 18.60 € | 16.20 € | 12.20 € |
| | | | Ø 6.3 x 12.7 mm | double cut | standard | 0 504 551 | 13.15 € | 10.00 € | 7.50 € |

matching set

| | | Order No. | Price from 1 set |
|---|--|------------------|---------------------|
| Sets of carbide milling cutters | | | |
|  | 10 milling cutters in the shapes cylinder Ø 1 x 4 mm (0 517 356), cylinder Ø 1.5 x 4 mm (0 517 357), rounded cylinder Ø 1 x 4 mm (0 517 348), rounded cylinder Ø 1.5 x 4 mm (0 517 349), sphere Ø 1 x 4 mm (0 517 354), sphere Ø 1.5 x 4 mm (0 517 355), drop Ø 1.5 x 4 mm (0 517 362), tree Ø 1.5 x 4 mm (0 517 361), tree with pointed end Ø 1.5 x 4 mm (0 517 350), pointed cone Ø 1.5 x 4 mm (0 517 351) | 0 517 300 | 100.30 € |
|  | 12 milling cutters in the shapes cylinder Ø 2.5 (0 501 442) and 3 mm (0 501 443), rounded cylinder (0 503 442), tree (0 504 442), tree with pointed end (0 505 443), drop (0 506 441), sphere Ø 25 (0 507 441) and 3 mm (0 507 443), pointed cone (0 508 442), rounded cone (0 509 442), flame (0 512 441) and trapezium (0 513 442) | 0 500 400 | 123.40 € |
|  | 10 milling cutters in the shapes cylinder (0 501 345), cylinder with end cut (0 501 342), round cylinder (0 501 332), rounded arch (0 501 312), tree with pointed end (0 501 352), drop (0 501 356), sphere (0 501 301), pointed cone (0 501 322), rounded cone (0 501 362) and trapezium (0 501 372) | 0 501 300 | 81.90 € |
|  | 9 milling cutters in the shapes cylinder (0 501 551), cylinder with end cut (0 502 551), round cylinder (0 503 551), tree (0 504 551), tree with pointed end (0 505 551), drop (0 506 551), sphere (0 507 551), pointed cone (0 508 551) and trapezium (0 513 551) | 0 500 551 | 147.55 € |

Ultrafine carbide milling cutters shank Ø 3 mm

| | Head dimensions | Shank Ø x total length | Cut | Design | Order No. | Price from | | |
|---|-----------------|------------------------|-----------|-------------|------------------|------------|----------|------------|
| | | | | | | 1 piece | 5 pieces | 100 pieces |
| Ultrafine carbide milling cutters, shank Ø 3 mm | | | | | | | | |
| cylinder | | | | | | | | |
|  | Ø 2 x 11 mm | Ø 3 x 38 mm | ultrafine | solid carb. | 0 527 510 | 17.05 € | 14.95 € | 11.90 € |
|  | Ø 3 x 14 mm | Ø 3 x 38 mm | ultrafine | solid carb. | 0 527 511 | 17.05 € | 14.95 € | 11.90 € |
|  | Ø 4 x 7 mm | Ø 3 x 39 mm | ultrafine | standard | 0 527 512 | 17.65 € | 15.55 € | 12.40 € |
| | Ø 6.3 x 12.7 mm | Ø 3 x 45 mm | ultrafine | standard | 0 527 513 | 17.65 € | 15.55 € | 12.50 € |
| rounded cylinder | | | | | | | | |
|  | Ø 2 x 11 mm | Ø 3 x 38 mm | ultrafine | solid carb. | 0 527 520 | 18.90 € | 16.50 € | 13.25 € |
|  | Ø 3 x 14 mm | Ø 3 x 38 mm | ultrafine | solid carb. | 0 527 521 | 18.90 € | 16.50 € | 13.25 € |
|  | Ø 6.3 x 12.7 mm | Ø 3 x 45 mm | ultrafine | standard | 0 527 522 | 19.85 € | 17.35 € | 13.90 € |
| sphere | | | | | | | | |
|  | Ø 2 mm | Ø 3 x 38 mm | ultrafine | solid carb. | 0 527 530 | 15.35 € | 13.45 € | 10.75 € |
|  | Ø 3 mm | Ø 3 x 38 mm | ultrafine | solid carb. | 0 527 531 | 15.35 € | 13.45 € | 10.75 € |
|  | Ø 4 mm | Ø 3 x 35 mm | ultrafine | standard | 0 527 532 | 16.00 € | 14.00 € | 11.25 € |
| | Ø 6.3 mm | Ø 3 x 38 mm | ultrafine | standard | 0 527 533 | 16.00 € | 14.00 € | 11.25 € |
| rounded arch | | | | | | | | |
|  | Ø 3 x 6 mm | Ø 3 x 38 mm | ultrafine | solid carb. | 0 527 540 | 19.05 € | 16.70 € | 11.25 € |
| | Ø 3 x 14 mm | Ø 3 x 38 mm | ultrafine | solid carb. | 0 527 541 | 19.05 € | 16.70 € | 13.35 € |
|  | Ø 6.3 x 12.7 mm | Ø 3 x 45 mm | ultrafine | standard | 0 527 542 | 20.10 € | 17.45 € | 14.00 € |
| tree with pointed end | | | | | | | | |
|  | Ø 3 x 14 mm | Ø 3 x 38 mm | ultrafine | solid carb. | 0 527 550 | 19.05 € | 16.70 € | 13.35 € |
|  | Ø 6.3 x 12.7 mm | Ø 3 x 45 mm | ultrafine | standard | 0 527 551 | 20.10 € | 17.45 € | 14.00 € |

↓ matching set

| | Order No. | Price from | |
|--|-----------|------------------|----------|
| | | 1 set | |
| Set of carbide milling cutters, ultrafine cut | | | |
| contents: | 10 pieces | 0 527 560 | 170.00 € |



For materials with a hardness of up to 65 HRC





















AlCrN-coated carbide milling cutters for hard materials

NEW!

AlCrN-coated milling points

AlCrN stands for aluminium chromium nitride and is a coating in which chromium has been replaced with titanium, thus achieving significantly higher performance. The coating thickness of 1 to 4 µm, a hardness of 3500 HV and temperature stability up to 1200°C convince with strength, resistance and the associated service life when using the milling cutter.

This high-performance coating is ideal for titanium, high-temperature alloys and steels that are difficult to machine.

| | Head dimensions | Shank Ø x total length | Cut | Design | Order No. | Price from | | |
|---|------------------|------------------------|------------|-------------|------------------|------------|----------|------------|
| | | | | | | 1 piece | 5 pieces | 100 pieces |
| AlCrN-coated carbide milling cutters | | | | | | | | |
| rounded cylinder | | | | | | | | |
|  | ▣ Ø 3 x 12.7 mm | Ø 3 x 38 mm | double cut | solid carb. | 0 501 730 | 9.90 € | 8.60 € | 6.90 € |
|  | Ø 4 x 12.7 mm | Ø 3 x 50 mm | double cut | standard | 0 501 731 | 14.20 € | 12.40 € | 10.00 € |
|  | Ø 4.75 x 12.7 mm | Ø 3 x 50 mm | double cut | standard | 0 501 732 | 14.20 € | 12.40 € | 10.00 € |
|  | Ø 6.3 x 12.7 mm | Ø 3 x 50 mm | double cut | standard | 0 501 733 | 16.80 € | 14.60 € | 11.80 € |
| sphere | | | | | | | | |
|  | ▣ Ø 3 x 2.4 mm | Ø 3 x 38 mm | double cut | solid carb. | 0 501 740 | 9.90 € | 8.60 € | 6.90 € |
|  | Ø 4 x 3.5 mm | Ø 3 x 42 mm | double cut | standard | 0 501 741 | 14.20 € | 12.40 € | 10.00 € |
| | Ø 4.75 x 4 mm | Ø 3 x 42 mm | double cut | standard | 0 501 742 | 14.20 € | 12.40 € | 10.00 € |
| | | Ø 3 x 82 mm | double cut | standard | 0 501 743 | 17.20 € | 15.00 € | 12.10 € |
|  | Ø 6.3 x 5.5 mm | Ø 3 x 44 mm | double cut | standard | 0 501 744 | 16.80 € | 14.60 € | 11.80 € |
| flame | | | | | | | | |
|  | ▣ Ø 3 x 6.3 mm | Ø 3 x 38 mm | double cut | solid carb. | 0 501 770 | 9.90 € | 8.60 € | 6.90 € |
|  | Ø 4.75 x 9.5 mm | Ø 3 x 48 mm | double cut | standard | 0 501 771 | 14.20 € | 12.40 € | 10.00 € |
| rounded arch | | | | | | | | |
|  | ▣ Ø 3 x 12.7 mm | Ø 3 x 38 mm | double cut | solid carb. | 0 501 750 | 9.90 € | 8.60 € | 6.90 € |
|  | Ø 4.75 x 12.7 mm | Ø 3 x 50 mm | double cut | standard | 0 501 751 | 14.20 € | 12.40 € | 10.00 € |
| | Ø 6.3 x 12.7 mm | Ø 3 x 50 mm | double cut | standard | 0 501 752 | 16.80 € | 14.60 € | 11.80 € |
| tree with pointed end | | | | | | | | |
|  | ▣ Ø 3 x 12.7 mm | Ø 3 x 38 mm | double cut | solid carb. | 0 501 760 | 9.90 € | 8.60 € | 6.90 € |
|  | Ø 4.75 x 12.7 mm | Ø 3 x 50 mm | double cut | standard | 0 501 761 | 14.20 € | 12.40 € | 10.00 € |
|  | Ø 6.3 x 12.7 mm | Ø 3 x 50 mm | double cut | standard | 0 501 762 | 16.80 € | 14.60 € | 11.80 € |
| drop | | | | | | | | |
|  | Ø 3 x 5.5 mm | Ø 3 x 38 mm | double cut | solid carb. | 0 501 780 | 9.90 € | 8.60 € | 6.90 € |
|  | Ø 4.75 x 7 mm | Ø 3 x 45 mm | double cut | standard | 0 501 781 | 14.20 € | 12.40 € | 10.00 € |
|  | Ø 6.3 x 9.5 mm | Ø 3 x 48 mm | double cut | standard | 0 501 782 | 16.80 € | 14.60 € | 11.80 € |
| cylinder – end mill | | | | | | | | |
|  | ▣ Ø 3 x 14 mm | Ø 3 x 38 mm | double cut | solid carb. | 0 501 720 | 9.90 € | 8.60 € | 6.90 € |
|  | Ø 4 x 12.7 mm | Ø 3 x 50 mm | double cut | standard | 0 501 721 | 14.20 € | 12.40 € | 10.00 € |
|  | Ø 4.75 x 12.7 mm | Ø 3 x 50 mm | double cut | standard | 0 501 722 | 14.20 € | 12.40 € | 10.00 € |
|  | Ø 6.3 x 12.7 mm | Ø 3 x 50 mm | double cut | standard | 0 501 723 | 16.80 € | 14.60 € | 11.80 € |











 **matching set**

| | | Order No. | Price from |
|---|----------|------------------|------------|
| | | | 1 set |
| Set of carbide milling cutters, AlCrN-coated | | | |
| contents: | 6 pieces | 0 501 710 | 64.50 € |

Carbide milling cutters shank Ø 6 mm

| | Head dimensions | Angle | Shank Ø x total length | Cut | Design | Order No. | Price from | | | |
|---|---|---------------|------------------------|--------------|------------------|------------------|------------------|----------|------------|---------|
| | | | | | | | 1 piece | 5 pieces | 100 pieces | |
| Carbide milling cutters, shank Ø 6 mm | | | | | | | | | | |
| cylinder | | | | | | | | | | |
|  | Ø 6 x 12.7 mm | | Ø 6 x 162 mm | double cut | standard | 0 501 951 | 20.10 € | 15.05 € | 11.25 € | |
|  | Ø 6 x 16 mm | | Ø 6 x 50 mm | double cut | solid carb. | 0 501 501 | 14.95 € | 11.15 € | 8.30 € | |
|  | Ø 6 x 19 mm | | Ø 6 x 50 mm | extra coarse | solid carb. | 0 526 001 | 20.10 € | 15.05 € | 11.25 € | |
|  | Ø 8 x 19 mm | | Ø 6 x 63 mm | double cut | standard | 0 501 602 | 19.05 € | 14.20 € | 10.85 € | |
| | Ø 9.5 x 19 mm | | Ø 6 x 63 mm | double cut | standard | 0 501 603 | 20.70 € | 15.55 € | 11.70 € | |
| | | | Ø 6 x 63 mm | extra coarse | standard | 0 526 002 | 29.65 € | 22.10 € | 16.80 € | |
| | Ø 12.7 x 25 mm | | Ø 6 x 69 mm | double cut | standard | 0 501 705 | 31.95 € | 23.85 € | 18.10 € | |
| cylinder – end mill | | | | | | | | | | |
|  | Ø 4 x 16 mm | | Ø 6 x 50 mm | diamond | solid carb. | 0 501 114 | 18.40 € | 13.80 € | 10.50 € | |
|  | Ø 6 x 16 mm | | Ø 6 x 50 mm | double cut | solid carb. | 0 502 501 | 16.00 € | 11.90 € | 8.95 € | |
| | Ø 6 x 18 mm | | Ø 6 x 63 mm | diamond | solid carb. | 0 501 115 | 20.20 € | 15.25 € | 11.35 € | |
| | Ø 8 x 19 mm | | Ø 6 x 63 mm | double cut | standard | 0 502 602 | 21.00 € | 15.90 € | 12.00 € | |
| | Ø 9.5 x 19 mm | | Ø 6 x 63 mm | double cut | standard | 0 502 603 | 22.50 € | 16.80 € | 12.75 € | |
| | Ø 10 x 20 mm | | Ø 6 x 60 mm | double cut | standard | 0 502 605 | 22.50 € | 16.80 € | 12.75 € | |
| | Ø 12 x 25 mm | | Ø 6 x 65 mm | double cut | standard | 0 502 607 | 35.00 € | 26.15 € | 20.00 € | |
| | Ø 12.7 x 25 mm | | Ø 6 x 69 mm | double cut | standard | 0 502 705 | 35.00 € | 26.15 € | 20.00 € | |
| rounded cylinder | | | | | | | | | | |
|  | Ø 5 x 16 mm | | Ø 6 x 50 mm | double cut | VHM | 0 503 500 | 18.35 € | 15.90 € | 12.40 € | |
| | Ø 6 x 12.7 mm | | Ø 6 x 162 mm | double cut | standard | 0 503 951 | 23.55 € | 17.55 € | 13.35 € | |
| | | | Ø 6 x 50 mm | double cut | solid carb. | 0 503 501 | 17.05 € | 12.85 € | 10.00 € | |
| | | | Ø 6 x 50 mm | extra coarse | solid carb. | 0 526 011 | 22.20 € | 16.60 € | 12.50 € | |
| |  | Ø 8 x 19 mm | | Ø 6 x 65 mm | double cut | standard | 0 503 602 | 20.90 € | 15.75 € | 12.50 € |
| | | Ø 9.5 x 19 mm | | Ø 6 x 63 mm | double cut | standard | 0 503 603 | 22.80 € | 17.05 € | 13.70 € |
| | | | | Ø 6 x 63 mm | extra coarse | standard | 0 526 012 | 29.65 € | 22.10 € | 16.80 € |
| | | Ø 10 x 20 mm | | Ø 6 x 60 mm | double cut | standard | 0 503 605 | 22.80 € | 17.05 € | 13.70 € |
| | Ø 12.7 x 25 mm | | Ø 6 x 69 mm | double cut | standard | 0 503 705 | 35.60 € | 26.70 € | 21.55 € | |
| | | | Ø 6 x 69 mm | extra coarse | standard | 0 526 013 | 43.30 € | 32.25 € | 24.60 € | |
| sphere | | | | | | | | | | |
|  | Ø 5 x 4 mm | | Ø 6 x 50 mm | normal | solid carb. | 0 503 109 | 15.80 € | 11.70 € | 8.85 € | |
| | | | Ø 6 x 50 mm | double cut | solid carb. | 0 507 514 | 15.80 € | 11.70 € | 8.85 € | |
| | Ø 6 x 5 mm | | Ø 6 x 50 mm | extra coarse | solid carb. | 0 526 021 | 21.75 € | 16.40 € | 12.40 € | |
| | | | Ø 6 x 50 mm | double cut | solid carb. | 0 507 501 | 15.80 € | 11.70 € | 8.85 € | |
| | | | Ø 6 x 155 mm | double cut | standard | 0 507 951 | 21.75 € | 16.40 € | 12.40 € | |
|  | Ø 8 x 6.4 mm | | Ø 6 x 50 mm | double cut | standard | 0 507 602 | 16.80 € | 12.65 € | 9.50 € | |
| | Ø 9.5 x 8 mm | | Ø 6 x 52 mm | double cut | standard | 0 507 603 | 18.80 € | 14.10 € | 10.75 € | |
| | | | Ø 6 x 52 mm | extra coarse | standard | 0 526 022 | 24.60 € | 18.40 € | 13.80 € | |
| | | | Ø 6 x 158 mm | double cut | standard | 0 507 952 | 26.30 € | 19.75 € | 14.95 € | |
| | Ø 10 x 9 mm | | Ø 6 x 49 mm | normal | standard | 0 503 113 | 26.60 € | 18.70 € | 13.55 € | |
| | | | Ø 6 x 49 mm | double cut | standard | 0 507 604 | 18.80 € | 14.10 € | 10.75 € | |
| | Ø 12 x 10.8 mm | | Ø 6 x 51 mm | normal | standard | 0 503 115 | 34.15 € | 23.45 € | 18.20 € | |
| Ø 12.7 x 11 mm | | Ø 6 x 55 mm | double cut | standard | 0 507 705 | 25.45 € | 18.90 € | 14.20 € | | |
| | | Ø 6 x 161 mm | double cut | standard | 0 507 953 | 35.20 € | 26.30 € | 20.10 € | | |



Carbide milling cutters shank Ø 6 mm

| | Head dimensions | Angle | Shank Ø x total length | Cut | Design | Order No. | Price from | | |
|---|------------------|----------------|------------------------|--------------|-------------|------------------|------------------|----------|------------|
| | | | | | | | 1 piece | 5 pieces | 100 pieces |
| tree with pointed end | | | | | | | | | |
|  | Ø 6 x 16 mm | | Ø 6 x 50 mm | double cut | solid carb. | 0 505 501 | 17.65 € | 13.25 € | 10.20 € |
|  | Ø 9.5 x 19 mm | | Ø 6 x 169 mm | double cut | standard | 0 505 952 | 33.10 € | 24.90 € | 18.70 € |
| | Ø 12.7 x 25 mm | | Ø 6 x 69 mm | double cut | standard | 0 505 705 | 32.25 € | 24.20 € | 18.30 € |
| pointed cone | | | | | | | | | |
|  | Ø 6 x 19 mm | 14° | Ø 6 x 50 mm | double cut | solid carb. | 0 508 502 | 18.00 € | 13.55 € | 10.40 € |
|  | Ø 9.5 x 16 mm | 28° | Ø 6 x 60 mm | double cut | standard | 0 508 604 | 28.40 € | 21.35 € | 16.30 € |
| | Ø 12.7 x 22 mm | 28° | Ø 6 x 69 mm | double cut | standard | 0 508 705 | 35.60 € | 26.70 € | 20.40 € |
| round cone | | | | | | | | | |
|  | Ø 6 x 16 mm | 14° | Ø 6 x 50 mm | double cut | solid carb. | 0 509 501 | 18.00 € | 13.55 € | 10.40 € |
|  | Ø 8 x 22 mm | 14° | Ø 6 x 69 mm | double cut | standard | 0 509 603 | 23.00 € | 17.15 € | 13.35 € |
| | Ø 12.7 x 28 mm | 14° | Ø 6 x 76 mm | double cut | standard | 0 509 704 | 34.80 € | 25.95 € | 19.85 € |
| trapeze | | | | | | | | | |
|  | Ø 12.7 x 12.7 mm | 28° | Ø 6 x 57 mm | double cut | standard | 0 513 703 | 35.40 € | 26.50 € | 20.30 € |
| drop | | | | | | | | | |
|  | Ø 6 x 9.5 mm | | Ø 6 x 50 mm | double cut | solid carb. | 0 506 501 | 19.05 € | 14.20 € | 10.95 € |
| | | | Ø 6 x 159 mm | double cut | standard | 0 506 951 | 26.50 € | 20.10 € | 15.15 € |
|  | Ø 9.5 x 16 mm | | Ø 6 x 60 mm | double cut | standard | 0 506 603 | 22.80 € | 17.05 € | 12.95 € |
| | | | Ø 6 x 60 mm | extra coarse | standard | 0 526 031 | 32.05 € | 24.05 € | 18.20 € |
| | | | Ø 6 x 66 mm | normal | standard | 0 503 219 | 33.30 € | 25.00 € | 18.80 € |
| | | | Ø 6 x 66 mm | double cut | standard | 0 506 705 | 33.30 € | 25.00 € | 18.80 € |
| | Ø 12.7 x 22 mm | | Ø 6 x 66 mm | extra coarse | standard | 0 526 032 | 39.50 € | 29.40 € | 22.40 € |
| flame | | | | | | | | | |
|  | Ø 8 x 19 mm | | Ø 6 x 63 mm | double cut | standard | 0 512 602 | 23.35 € | 17.45 € | 13.25 € |
| | | | Ø 6 x 169 mm | double cut | standard | 0 512 951 | 32.70 € | 24.70 € | 18.50 € |
| | | Ø 12.7 x 32 mm | | Ø 6 x 76 mm | double cut | standard | 0 512 705 | 47.40 € | 35.40 € |
| rounded arch | | | | | | | | | |
|  | Ø 6 x 12.7 mm | | Ø 6 x 163 mm | double cut | solid carb. | 0 504 951 | 24.80 € | 18.50 € | 14.00 € |
| | Ø 6 x 16 mm | | Ø 6 x 50 mm | double cut | solid carb. | 0 504 501 | 17.65 € | 13.25 € | 10.20 € |
| | Ø 6 x 19 mm | | Ø 6 x 50 mm | extra coarse | solid carb. | 0 526 041 | 22.20 € | 16.60 € | 12.50 € |
| | Ø 9.5 x 19 mm | | Ø 6 x 63 mm | double cut | standard | 0 504 603 | 22.30 € | 16.70 € | 12.60 € |
| | | | Ø 6 x 63 mm | extra coarse | standard | 0 526 042 | 31.30 € | 23.25 € | 17.75 € |
| | | Ø 12.7 x 25 mm | | Ø 6 x 69 mm | double cut | standard | 0 504 705 | 32.80 € | 24.80 € |
| | | | Ø 6 x 75 mm | extra coarse | standard | 0 526 043 | 43.80 € | 32.70 € | 25.00 € |
| countersunk 60° | | | | | | | | | |
|  | Ø 9.5 x 8 mm | 60° | Ø 6 x 55 mm | double cut | standard | 0 511 603 | 20.60 € | 15.45 € | 11.60 € |
| countersunk 90° | | | | | | | | | |
|  | Ø 6 x 3 mm | 90° | Ø 6 x 50 mm | double cut | solid carb. | 0 510 501 | 15.80 € | 11.70 € | 8.85 € |
| | Ø 9.5 x 4.7 mm | 90° | Ø 6 x 52 mm | double cut | standard | 0 510 603 | 20.60 € | 15.45 € | 11.60 € |
| | Ø 16 x 8 mm | 90° | Ø 6 x 57 mm | double cut | standard | 0 510 706 | 32.80 € | 24.80 € | 18.60 € |
| | Ø 19 x 9.5 mm | 90° | Ø 6 x 58 mm | double cut | standard | 0 510 707 | 43.20 € | 32.15 € | 24.60 € |

Carbide milling cutters

shank Ø 6 mm

 *matching set*









| | Order No. | Price from 1 set |
|---|---|---------------------------|
| Sets of carbide milling cutters | | |
|  | 6 milling cutters in the shapes cylinder (0 501 501), rounded cylinder (0 503 501), tree (0 504 501), drop (0 506 501), sphere (0 507 501) and rounded cone (0 509 501) | 0 500 500 112.90 € |
|  | 6 milling cutters in the shapes cylinder (0 501 603), rounded cylinder (0 503 603), tree (0 504 603), drop (0 506 603), sphere (0 507 603) and rounded cone (0 509 603) | 0 500 600 141.05 € |



Ultrafine carbide milling cutters shank Ø 6 mm

Ultrafine carbide milling cutters

Ultrafine tungsten carbide milling cutters are designed for very fine finishing. They are characterised by efficient stock removal with simultaneously good surface quality. Almost all materials up to a hardness of 65 HRC can be machined. These milling cutters are also optimally suited to applications in which normal grinding points would be suitable, but greater stock removal is required. This product series is frequently used for punching and cutting tools in toolmaking and mould building.

| | Head dimensions | Shank Ø x total length | Cut | Design | Order No. | Price from | | |
|---|------------------|------------------------|-----------|-------------|------------------|------------|----------|------------|
| | | | | | | 1 piece | 5 pieces | 100 pieces |
| Ultrafine carbide milling cutters, shank Ø 6 mm | | | | | | | | |
| cylinder – end mill | | | | | | | | |
|  | ↓ Ø 6 x 18 mm | Ø 6 x 50 mm | ultrafine | solid carb. | 0 527 514 | 25.95 € | 21.65 € | 19.45 € |
| rounded cylinder | | | | | | | | |
|  | ↓ | Ø 6 x 50 mm | ultrafine | solid carb. | 0 527 524 | 26.30 € | 21.85 € | 19.75 € |
|  | Ø 12.7 x 25 mm | Ø 6 x 70 mm | ultrafine | standard | 0 527 523 | 38.05 € | 31.75 € | 28.50 € |
| sphere | | | | | | | | |
|  | Ø 6 mm | Ø 6 x 50 mm | ultrafine | solid carb. | 0 527 535 | 21.35 € | 17.75 € | 16.00 € |
|  | ↓ Ø 10 mm | Ø 6 x 54 mm | ultrafine | standard | 0 527 534 | 24.70 € | 20.60 € | 18.50 € |
| rounded arch | | | | | | | | |
|  | Ø 6 x 18 mm | Ø 6 x 50 mm | ultrafine | solid carb. | 0 527 543 | 26.50 € | 22.10 € | 20.00 € |
| tree with pointed end | | | | | | | | |
|  | ↓ Ø 6 x 18 mm | Ø 6 x 50 mm | ultrafine | solid carb. | 0 527 552 | 27.00 € | 22.50 € | 20.40 € |
| pointed cone | | | | | | | | |
|  | ↓ Ø 12.7 x 22 mm | Ø 6 x 71 mm | ultrafine | standard | 0 527 584 | 34.90 € | 29.00 € | 26.15 € |
| tree with pointed end | | | | | | | | |
|  | ↓ Ø 12.7 x 30 mm | Ø 6 x 75 mm | ultrafine | standard | 0 527 553 | 36.05 € | 31.50 € | 27.10 € |

↓ matching set

| | Order No. | Price from |
|--|------------------|------------|
| Set of carbide milling cutters, ultrafine cut | | 1 set |
| contents: 6 pieces | 0 527 570 | 166.00 € |



For materials with a hardness of up to 65 HRC

Circular saw blades

Solid carbide metal

Solid carbide circular saw blades

The solid carbide circular saw blades are high quality products with a precision cut and lateral hollow grinding by the mirror-grinding process for slotting and separating. The cutting speed can be increased 3 to 4-fold by using solid carbide circular saw blades in comparison to HSS saw blades. Furthermore, high-strength materials with 800 - 1200 N/mm² and abrasive materials can be readily processed (e.g. tungsten copper, copper, aluminium, stainless steel, titanium, cast iron, brass, bronze, thermoplastics and duroplastics).

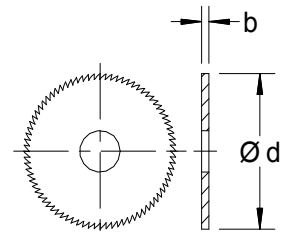

| | Nom. Ø d x cutting width b | Material | Drilling dimension | Design | Order No. | Price from 1 piece |
|---|----------------------------|-------------|--------------------|----------|------------------|--------------------|
| Solid carbide circular saw blades | | | | | | |
|  | Ø 30 x 0.4 mm | solid carb. | 8 mm | 80 teeth | 0 500 384 | 27.30 € |
| | Ø 30 x 0.5 mm | solid carb. | 8 mm | 80 teeth | 0 500 385 | 27.30 € |
| | Ø 30 x 0.8 mm | solid carb. | 8 mm | 64 teeth | 0 500 386 | 35.20 € |

Accessories / spare parts

| | for bore dimensions | Shank dimensions | Type | Order No. | Price from 1 piece |
|---|---------------------|------------------|------|------------------|--------------------|
| Cut-off disc receptacles with carbide metal shank | | | | | |
|  | 8 mm | Ø 3 x 45 mm | TA8 | 0 561 947 | 59.25 € |
| | | Ø 6 x 45 mm | TA8 | 0 561 948 | 60.80 € |

Gravers

Solid carbide metal



Pre-ground - K 10 grade. For processing steel, grey cast iron, non-ferrous metals and plastic. The preworked profiles can be suitably ground with little effort and thus be optimally adapted to the respective application. Typical areas of use include for example, die making and mouldbuilding, copy milling and engraving characters, etc. Worn cutting edges can be rendered usable again by simply regrinding. The angles must be adapted to the material to be processed.



Other dimensions available.

Call our product manager:
Stefan Spiegel:

Tel. +49 (0) 22 04 / 8 39-0
s.spiegel@joke.de

| | Dimensions | Angle | Order No. | Price from | |
|---|-------------|-------|------------------|------------|----------|
| | | | | 1 piece | 5 pieces |
| Solid carbide gravers | | | | | |
| rod | | | | | |
|  | Ø 3 x 75 mm | | 0 517 472 | 10.60 € | 7.80 € |
| | Ø 6 x 75 mm | | 0 517 474 | 20.40 € | 15.00 € |
| flat, halved on one side | | | | | |
|  | Ø 4 x 40 mm | | 0 517 482 | 14.90 € | 10.80 € |
| | Ø 6 x 75 mm | | 0 517 483 | 29.65 € | 21.55 € |
| pointed | | | | | |
|  | Ø 3 x 40 mm | 60° | 0 517 487 | 16.55 € | 12.20 € |
| | Ø 4 x 40 mm | 60° | 0 517 488 | 20.10 € | 14.70 € |
| | Ø 6 x 75 mm | 60° | 0 517 489 | 38.15 € | 27.80 € |

Solid carbide microdrills Shank Ø 3 mm

These spiral drills exactly match the spirit of the times and fulfil the high demands of industry. The main advantages of solid carbide drills lie in the short processing times, very minor signs of wear, higher cutting speeds and increased service lives. Furthermore, they are distinguished by high rigidity, very good positioning precision and good centring and guiding characteristics. This becomes particularly apparent in processing abrasive materials such as cast iron, aluminium alloys with a high silicon content, fibreglass-reinforced materials and graphite.

| | Nominal Ø x clamping groove length D x SL | Projection length L1 | Shank Ø x total length | Order No. | Price from 1 piece |
|--|---|----------------------|------------------------|------------------|--------------------|
| Solid carbide microdrills, TiAlN-coated | | | | | |
| | Ø 0.100 x 1.2 mm | 10 mm | 3 x 38 mm | 0 510 301 | 18.50 € |
| | Ø 0.200 x 2.5 mm | 10 mm | 3 x 38 mm | 0 510 302 | 19.80 € |
| | Ø 0.300 x 5 mm | 11.7 mm | 3 x 38 mm | 0 510 303 | 21.35 € |
| | Ø 0.400 x 7 mm | 12.7 mm | 3 x 38 mm | 0 510 304 | 24.10 € |
| | Ø 0.500 x 7 mm | 12.7 mm | 3 x 38 mm | 0 510 305 | 23.50 € |
| | Ø 0.600 x 7 mm | 12.7 mm | 3 x 38 mm | 0 510 306 | 21.55 € |
| | Ø 0.700 x 8 mm | 12.5 mm | 3 x 38 mm | 0 510 307 | 20.00 € |
| | Ø 0.800 x 10 mm | 14.4 mm | 3 x 38 mm | 0 510 308 | 20.40 € |
| | Ø 0.900 x 10 mm | 14.2 mm | 3 x 38 mm | 0 510 309 | 23.00 € |
| | Ø 1.000 x 10 mm | 14 mm | 3 x 38 mm | 0 510 310 | 20.75 € |
| | Ø 1.100 x 10 mm | 13.8 mm | 3 x 38 mm | 0 510 311 | 20.95 € |
| | Ø 1.200 x 10 mm | 13.6 mm | 3 x 38 mm | 0 510 312 | 23.00 € |
| | Ø 1.300 x 10 mm | 13.4 mm | 3 x 38 mm | 0 510 313 | 23.00 € |
| | Ø 1.400 x 10 mm | 13.2 mm | 3 x 38 mm | 0 510 314 | 23.00 € |
| | Ø 1.500 x 10 mm | 13 mm | 3 x 38 mm | 0 510 315 | 23.00 € |
| | Ø 1.600 x 12 mm | 14.9 mm | 3 x 38 mm | 0 510 316 | 23.50 € |
| | Ø 1.700 x 12 mm | 14.7 mm | 3 x 38 mm | 0 510 317 | 20.95 € |
| | Ø 1.800 x 12 mm | 14.5 mm | 3 x 38 mm | 0 510 318 | 23.50 € |
| | Ø 1.900 x 12 mm | 14.3 mm | 3 x 38 mm | 0 510 319 | 23.50 € |
| | Ø 2.000 x 12 mm | 14.1 mm | 3 x 38 mm | 0 510 320 | 23.00 € |
| | Ø 2.100 x 12 mm | 13.9 mm | 3 x 38 mm | 0 510 321 | 21.05 € |
| | Ø 2.200 x 12 mm | 13.7 mm | 3 x 38 mm | 0 510 322 | 21.55 € |
| | Ø 2.400 x 12 mm | 13.4 mm | 3 x 38 mm | 0 510 324 | 20.50 € |
| | Ø 2.500 x 12 mm | 13.2 mm | 3 x 38 mm | 0 510 325 | 20.95 € |
| | Ø 2.600 x 12 mm | 13 mm | 3 x 38 mm | 0 510 326 | 23.00 € |
| | Ø 2.700 x 12 mm | 12.8 mm | 3 x 38 mm | 0 510 327 | 25.15 € |
| | Ø 2.800 x 12 mm | 12.6 mm | 3 x 38 mm | 0 510 328 | 25.15 € |
| | Ø 2.900 x 12 mm | 12.4 mm | 3 x 38 mm | 0 510 329 | 25.15 € |
| | Ø 3.000 x 12 mm | 12.3 mm | 3 x 38 mm | 0 510 330 | 21.05 € |

Reverse deburrer 45° shank Ø 3 and 6 mm

NEW!

Hard-to-reach areas when deburring drilling holes are no longer a problem with this carbide reverse deburrer. Its decisive advantages are the defined 45° bevel, its suitability for different drilling hole diameters and the variable bevel width. This simplifies processing and achieves a rapid working result.

| | Head dimensions | Angle | Shank Ø x total length | Cut | Design | Order No. | Price from | | |
|-----------------------------|-----------------|-------|------------------------|---------------------------|-------------|------------------|------------|----------|------------|
| | | | | | | | 1 piece | 5 pieces | 100 pieces |
| Reverse deburrer 45° | | | | | | | | | |
| | Ø 5 mm | 45° | Ø 3 x 40 mm | left-hand helical gearing | solid carb. | 0 501 390 | 33.05 € | 29.95 € | 26.55 € |
| | Ø 7 mm | 45° | Ø 3 x 40 mm | left-hand helical gearing | solid carb. | 0 501 391 | 37.85 € | 34.25 € | 30.45 € |
| | Ø 10 mm | 45° | Ø 6 x 60 mm | left-hand helical gearing | solid carb. | 0 501 392 | 43.70 € | 39.60 € | 35.10 € |
| | Ø 12 mm | 45° | Ø 6 x 65 mm | left-hand helical gearing | solid carb. | 0 501 393 | 49.45 € | 44.80 € | 39.80 € |

Filing tools





Steel needle files are used by hand (with an appropriate file handle) or on a hand filing machine. They are excellent for processing the smallest surfaces, openings, shapes, profiles and radii. Steel needle files from JOKO are extremely precise and sharp-edged and have perfectly carved cuts. The practically oriented file shapes convince by their pointed shapes, sharp edges and long service life.

403 Steel needle files



407 Emery files

The steel needle files are mainly used for steel and steel alloys in addition to nonsmearing soft metals. The new emery files are perfectly suited for precise work within the smallest space. They have a very long service life, are unbreakable and are easy to clean, regardless of whether tungsten carbide, titanium, steel or similar materials are being worked.

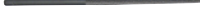
Steel needle files shank Ø 3 mm, total length 85 mm





| | Dimensions | Coating dimensions | Shank dimensions | Total length | Cut | Order No. | Price from | |
|---|--------------|--------------------|------------------|--------------|-----------|------------------|------------|-----------|
| | | | | | | | 1 piece | 10 pieces |
| Steel needle files, shank Ø 3 mm | | | | | | | | |
| triangular | | | | | | | | |
|  | 3.5 x 3.5 mm | 57 mm | Ø 3 | 85 mm | 00 coarse | 0 400 042 | 15.35 € | 13.70 € |
| | | 57 mm | Ø 3 | 85 mm | 1 medium | 0 400 043 | 15.50 € | 13.95 € |
| flat | | | | | | | | |
|  | 5 x 1.5 mm | 57 mm | Ø 3 | 85 mm | 00 coarse | 0 400 012 | 11.95 € | 10.85 € |
| | | 57 mm | Ø 3 | 85 mm | 1 medium | 0 400 013 | 12.10 € | 11.05 € |
| halfround | | | | | | | | |
|  | 5 x 2 mm | 57 mm | Ø 3 | 85 mm | 00 coarse | 0 400 022 | 16.20 € | 14.85 € |
| | | 57 mm | Ø 3 | 85 mm | 1 medium | 0 400 023 | 16.30 € | 14.95 € |
| square | | | | | | | | |
|  | 2.5 x 2.5 mm | 57 mm | Ø 3 | 85 mm | 00 coarse | 0 400 052 | 14.05 € | 12.80 € |
| | | 57 mm | Ø 3 | 85 mm | 1 medium | 0 400 053 | 14.25 € | 12.80 € |
| round | | | | | | | | |
|  | Ø 3 mm | 57 mm | Ø 3 | 85 mm | 00 coarse | 0 400 032 | 12.90 € | 11.75 € |
| | | 57 mm | Ø 3 | 85 mm | 1 medium | 0 400 033 | 13.00 € | 11.85 € |

Accessories / spare parts

| | Order No. | Price from | |
|---|--|--------------------|-------------------|
| | | 1 piece | 10 pieces |
| Plastic handle | | | |
|  | suitable for Ø 3 mm shanks | 0 400 892 | 1.15 € 1.06 € |
| Plastic handle, red | | | |
|  | with clamping lever for files up to 150 mm length, tension area Ø 2.5 – 4 mm | 0 400 894-0 | 10.75 € 8.45 € |

Steel needle files

shank Ø 2 mm, total length 100 mm









| | Dimensions | Coating dimensions | Shank dimensions | Total length | Cut | Order No. | Price from | |
|---|--------------|--------------------|------------------|--------------|-----------|------------------|------------|-----------|
| | | | | | | | 1 piece | 10 pieces |
| Steel needle files, shank Ø 2 mm | | | | | | | | |
| triangular | | | | | | | | |
|  | 2.2 x 2.2 mm | 47 mm | Ø 2 | 100 mm | 00 coarse | 0 400 342 | 15.45 € | 14.05 € |
| | | 47 mm | Ø 2 | 100 mm | 1 medium | 0 400 343 | 17.55 € | 15.90 € |
| flat | | | | | | | | |
|  | 3.3 x 1 mm | 47 mm | Ø 2 | 100 mm | 00 coarse | 0 400 312 | 20.60 € | 18.55 € |
| | | 47 mm | Ø 2 | 100 mm | 1 medium | 0 400 313 | 20.75 € | 18.65 € |
| halfround | | | | | | | | |
|  | 3.2 x 1.1 mm | 47 mm | Ø 2 | 100 mm | 00 coarse | 0 400 322 | 21.95 € | 20.10 € |
| | | 47 mm | Ø 2 | 100 mm | 1 medium | 0 400 323 | 19.00 € | 17.10 € |
| square | | | | | | | | |
|  | 1.7 x 1.7 mm | 47 mm | Ø 2 | 100 mm | 00 coarse | 0 400 352 | 18.25 € | 16.60 € |
| | | 47 mm | Ø 2 | 100 mm | 1 medium | 0 400 353 | 18.65 € | 16.70 € |
| round | | | | | | | | |
|  | Ø 2 mm | 47 mm | Ø 2 | 100 mm | 00 coarse | 0 400 332 | 13.50 € | 12.50 € |
| | | 47 mm | Ø 2 | 100 mm | 1 medium | 0 400 333 | 13.60 € | 12.60 € |

Steel needle files

shank Ø 3.5 mm, total length 100 mm

| | Dimensions | Coating dimensions | Shank dimensions | Total length | Cut | Order No. | Price from | |
|---|-------------|--------------------|------------------|--------------|-----------|------------------|------------|-----------|
| | | | | | | | 1 piece | 10 pieces |
| Steel needle files, shank Ø 3.5 mm | | | | | | | | |
| flat, blunt | | | | | | | | |
|  | 10 x 2.5 mm | 72 mm | Ø 3.5 | 100 mm | 00 coarse | 0 400 412 | 19.70 € | 17.85 € |
| | | 72 mm | Ø 3.5 | 100 mm | 1 medium | 0 400 413 | 20.00 € | 18.05 € |

Steel needle files shank Ø 3 mm, total length 160 mm





| | Dimensions | Coating dimensions | Shank dimensions | Total length | Cut | Order No. | Price from | |
|---|--------------|--------------------|------------------|--------------|----------|------------------|------------|-----------|
| | | | | | | | 1 piece | 10 pieces |
| Steel needle files, shank Ø 3 mm | | | | | | | | |
| beret | | | | | | | | |
|  | 5.5 x 2.2 mm | 78 mm | Ø 3 | 160 mm | 0 coarse | 0 400 610 | 6.60 € | 6.10 € |
| | | 78 mm | Ø 3 | 160 mm | 1 medium | 0 400 611 | 6.60 € | 6.10 € |
| | | 78 mm | Ø 3 | 160 mm | 2 fine | 0 400 612 | 6.60 € | 6.10 € |
| triangular | | | | | | | | |
|  | 3.5 x 3.5 mm | 78 mm | Ø 3 | 160 mm | 0 coarse | 0 400 580 | 6.60 € | 6.10 € |
| | | 78 mm | Ø 3 | 160 mm | 1 medium | 0 400 581 | 6.60 € | 6.10 € |
| | | 78 mm | Ø 3 | 160 mm | 2 fine | 0 400 582 | 6.60 € | 6.10 € |
| flat, pointed | | | | | | | | |
|  | 5.5 x 1.5 mm | 78 mm | Ø 3 | 160 mm | 0 coarse | 0 400 530 | 6.60 € | 6.10 € |
| | | 78 mm | Ø 3 | 160 mm | 1 medium | 0 400 531 | 6.60 € | 6.10 € |
| | | 78 mm | Ø 3 | 160 mm | 2 fine | 0 400 532 | 6.60 € | 6.10 € |
| flat, blunt | | | | | | | | |
|  | | 78 mm | Ø 3 | 160 mm | 0 coarse | 0 400 510 | 6.10 € | 5.60 € |
| | | 78 mm | Ø 3 | 160 mm | 1 medium | 0 400 511 | 6.10 € | 5.60 € |
| | | 78 mm | Ø 3 | 160 mm | 2 fine | 0 400 512 | 6.10 € | 5.60 € |
| flat, blunt- round edges | | | | | | | | |
|  | | 78 mm | Ø 3 | 160 mm | 0 coarse | 0 400 520 | 7.05 € | 6.70 € |
| | | 78 mm | Ø 3 | 160 mm | 1 medium | 0 400 521 | 7.05 € | 6.70 € |
| | | 78 mm | Ø 3 | 160 mm | 2 fine | 0 400 522 | 7.05 € | 6.70 € |
| halfround | | | | | | | | |
|  | 5.5 x 2.2 mm | 78 mm | Ø 3 | 160 mm | 0 coarse | 0 400 550 | 7.05 € | 6.70 € |
| | | 78 mm | Ø 3 | 160 mm | 1 medium | 0 400 551 | 7.05 € | 6.70 € |
| | | 78 mm | Ø 3 | 160 mm | 2 fine | 0 400 552 | 7.05 € | 6.70 € |
| square | | | | | | | | |
|  | 2.5 x 2.5 mm | 78 mm | Ø 3 | 160 mm | 0 coarse | 0 400 590 | 7.55 € | 7.15 € |
| | | 78 mm | Ø 3 | 160 mm | 1 medium | 0 400 591 | 7.55 € | 7.15 € |
| | | 78 mm | Ø 3 | 160 mm | 2 fine | 0 400 592 | 7.55 € | 7.15 € |
| round | | | | | | | | |
|  | Ø 3.5 mm | 78 mm | Ø 3 | 160 mm | 0 coarse | 0 400 600 | 6.10 € | 5.60 € |
| | | 78 mm | Ø 3 | 160 mm | 1 medium | 0 400 601 | 6.10 € | 5.60 € |
| | | 78 mm | Ø 3 | 160 mm | 2 fine | 0 400 602 | 6.10 € | 5.60 € |

Accessories / spare parts

| | Order No. | Price from | |
|---|--|--------------------|-------------------|
| | | 1 piece | 10 pieces |
| Plastic handle, red | | | |
|  | with clamping lever for files up to 150 mm length, tension area Ø 2.5 – 4 mm | 0 400 894-0 | 10.75 € 8.45 € |

Steel Riffler files

shank Ø 3 mm, total length 85 mm

| | Dimensions | Coating dimensions | Shank dimensions | Total length | Cut | Order No. | Price from | |
|---|--------------|--------------------|------------------|--------------|----------|------------------|------------|-----------|
| | | | | | | | 1 piece | 10 pieces |
| Steel Riffler files, shank Ø 3 mm | | | | | | | | |
| flat, blunt | | | | | | | | |
|  | 4 x 2 mm | 40 mm | Ø 3 | 85 mm | 1 medium | 0 400 113 | 17.75 € | 16.20 € |
| halfround, crossing | | | | | | | | |
|  | 4.7 x 2.5 mm | 40 mm | Ø 3 | 85 mm | 1 medium | 0 400 143 | 34.10 € | 31.05 € |
| square, pointed | | | | | | | | |
|  | 3 x 3 mm | 40 mm | Ø 3 | 85 mm | 1 medium | 0 400 123 | 21.95 € | 20.10 € |
| round/pointed | | | | | | | | |
|  | Ø 3 mm | 40 mm | Ø 3 | 85 mm | 1 medium | 0 400 133 | 20.30 € | 18.15 € |

Accessories / spare parts

| | Order No. | Price from |
|---|------------------|------------|
| | | 1 piece |
| Blowing pen | | |
|  | | |
| For direct connection to a rapid coupling system. Dimensions: Ø12.5 x 108 mm Weight: 20 g | 0 203 200 | 22.70 € |

The perfect complement

Cleaning fluid X 73016-A

- Ideal for cleaning moulds and workpieces
- Evaporates rapidly and without leaving residues
- For all metals, glass, ceramics and almost all plastics



| Order No. | Price |
|------------------|--------|
| 0 580 521 | 6.75 € |

The perfect complement

Universal-Spray joke X 73020

- five products rolled into one: corrosion protection, cleaning, water repellence, lubrication and preservation
- cleans surfaces and cares for tools



| Order No. | Price |
|------------------|--------|
| 0 580 526 | 5.45 € |

Emery files

total length 140 mm

Emery files

The new emery files from joke are optimally suited for ultimate finishing. The strength of the tool and the different shapes allow precision work within the smallest space. A diamond coating allows use on carbide metals, titanium, steel or ceramic. They are impact-resistant and do not break like stone (Degussit). Owing to its hard surface, the tool is particularly durable, keeps its shape and does not need any reworking. The corrosion-resistant files can be easily cleaned using ultrasound, petroleum or cleaning compound. The product is Swiss-made quality.



| | Dimensions | Coating dimensions | Total length | Grit size | Order No. | Price from | |
|--|--------------|--------------------|--------------|-----------|------------------|------------|----------|
| | | | | | | 1 piece | 6 pieces |
| Escapement file, shank Ø 3.5 mm | | | | | | | |
| beret | | | | | | | |
| | 3.9 x 1.2 mm | 50 mm | 140 mm | G10, fine | 0 572 237 | 39.20 € | 36.05 € |
| crossing | | | | | | | |
| | 3.7 x 1.4 mm | 50 mm | 140 mm | G10, fine | 0 572 238 | 35.05 € | 32.20 € |
| triangular | | | | | | | |
| | 2.8 mm | 50 mm | 140 mm | G10, fine | 0 572 233 | 36.45 € | 33.50 € |
| flat, blunt | | | | | | | |
| | 3.9 x 0.8 mm | 50 mm | 140 mm | G10, fine | 0 572 232 | 35.05 € | 32.20 € |
| halfround | | | | | | | |
| | 4 x 1.3 mm | 50 mm | 140 mm | G10, fine | 0 572 235 | 39.20 € | 36.05 € |
| square | | | | | | | |
| | 1.7 mm | 50 mm | 140 mm | G10, fine | 0 572 234 | 35.05 € | 32.20 € |
| round | | | | | | | |
| | Ø 1.5 mm | 50 mm | 140 mm | G10, fine | 0 572 236 | 36.45 € | 33.50 € |

matching set







| | Grit size | Order No. | Price from | |
|----------------------------------|--------------------------------------|-----------|------------------|----------|
| | | | 1 set | |
| Emery escapement file set | | | | |
| | Set consisting of 6 escapement files | G10, fine | 0 572 221 | 124.55 € |

Accessories / spare parts

| | Order No. | Price from | |
|-------------------------|---|------------------|------------------|
| | | 1 piece | 5 pieces |
| Universal handle | | | |
| | for receiving deburring tools, needle files, etc. Flexible collet with a clamping range of between 2.2 and 4.5 mm | 0 413 939 | 6.95 € 6.60 € |

Emery files

total length 140 mm

| | Dimensions | Coating dimensions | Total length | Grit size | Order No. | Price from | |
|---|--------------|--------------------|--------------|-----------|------------------|------------|----------|
| | | | | | | 1 piece | 6 pieces |
| Needle file, shank Ø 3.5 mm | | | | | | | |
| beret | | | | | | | |
|  | 4.7 x 1.4 mm | 85 mm | 140 mm | G10, fine | 0 572 230 | 53.30 € | 48.95 € |
| crossing | | | | | | | |
|  | 4.4 x 1.8 mm | 85 mm | 140 mm | G10, fine | 0 572 231 | 50.45 € | 46.30 € |
| triangular | | | | | | | |
|  | 3.5 mm | 85 mm | 140 mm | G10, fine | 0 572 226 | 49.85 € | 45.90 € |
| flat, blunt | | | | | | | |
|  | 4.8 x 1 mm | 85 mm | 140 mm | G10, fine | 0 572 225 | 49.85 € | 45.90 € |
| halfround | | | | | | | |
|  | 5.1 x 1.6 mm | 85 mm | 140 mm | G10, fine | 0 572 228 | 56.45 € | 51.80 € |
| square | | | | | | | |
| | 2.2 mm | 85 mm | 140 mm | G10, fine | 0 572 227 | 47.55 € | 43.65 € |
| round | | | | | | | |
|  | Ø 2.8 mm | 85 mm | 140 mm | G10, fine | 0 572 229 | 49.85 € | 45.90 € |



matching set

| | Grit size | Order No. | Price from | |
|---|----------------------------------|-----------|------------------|----------|
| | | | 1 set | |
| Emery needle file set | | | | |
|  | Set consisting of 6 needle files | G10, fine | 0 572 220 | 179.00 € |

Accessories / spare parts

| | Order No. | Price from | |
|---|---|------------------|---------------|
| | | 1 piece | 5 pieces |
| Universal handle | | | |
|  | for receiving deburring tools, needle files, etc. Flexible collet with a clamping range of between 2.2 and 4.5 mm | 0 413 939 | 6.95 € 6.60 € |

NEW!

ENESKAsonic

The most innovative advancement
in the field of ultrasonics





- intuitive touch operation combined with a rotary controller on high-quality glass
- modern LED-assisted multifunctional display
- Boost function for applications requiring greater power
- Idle timer detects unused hand-pieces and protects against wear
- USB charging connection enables for example optional addition of a workplace light without a further power source



Want to know more about our
ENESKAsonic? Find out all about
our international innovation on **Page 7**.

100%
Made in GERMANY

Deburring tools

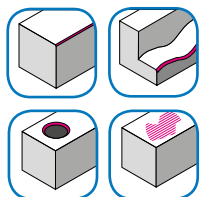

| | | Order No. | Price from | |
|---|---|------------------------------------|------------------|--------------------|
| | | | 1 piece | 5 pieces |
| Hand deburrer MF 400 |  | blade 20 x 4 x 0.35 mm | 0 401 999 | 20.75 € |
| Hand deburrer KE 40 |  | blade 40 x 14 x 1.5 mm | 0 402 001 | 39.10 € |
| Hand deburrer KE 25 |  | blade 25 x 5 x 1.5 mm | 0 402 002 | 33.85 € |
| Hand deburrer with ceramic blade |  | ergonomic handle with soft padding | 0 413 921 | 53.50 € 52.05 € |

Accessories / spare parts



| | Packing quantity | Order No. | Price from | |
|--|------------------|------------------|------------|--|
| | | | 1 pack | |
| Spare blades for hand deburrer MF 400 | 5 pieces | 0 401 998 | 20.20 € | |



| | | Order No. | Price from | |
|---------------------------------|---|---|------------------|---------|
| | | | 1 piece | |
| Reverse deburrer RC 1000 |  | bore Ø 3 – 5.5 mm, workpiece thickness up to 18 mm | 0 402 003 | 42.85 € |
| Reverse deburrer RC 2000 |  | bore Ø 5.5 – 10 mm, workpiece thickness up to 24 mm | 0 402 005 | 42.85 € |

Accessories / spare parts

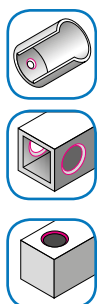

| | Order No. | Price from | |
|---|---|------------------|--------------------|
| | | 1 piece | 10 pieces |
| Spare blade for reverse deburrer RC 1000 |  | 0 402 004 | 21.15 € 18.55 € |
| Spare blade for reverse deburrer RC 2000 |  | 0 402 006 | 10.10 € 9.00 € |

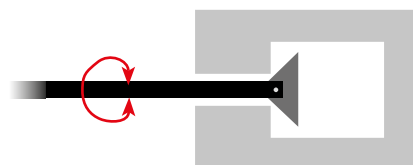





Deburring tools

- Lies firmly in your hand owing to non-slip plastic casing
- Protective cap to reduce risk of injury
- Knurled screw for easy blade change and absolutely secure hold of blades
- Spare blades in handy dispenser

| | Order No. | Price from 1 piece |
|---|---|-----------------------|
| Deburring knife, red, with replaceable blade | | |
|  | with rapid-change blade 0 402 000 | 10.40 € |

⚙️ Accessories / spare parts

| | Packing quantity | Order No. | Price from 1 pack |
|--|------------------|------------------|----------------------|
| Spare blade dispenser | | | |
|  | 100 pieces | 0 402 009 | 28.20 € |

| | Order No. | Price from 1 piece |
|---|--|--------------------------|
| Mini deburrer FT10001 | | |
|  | fixed HSS blade S150 with handle, for extra-fine deburring work (the blade is non-replaceable) | 0 413 961 9.00 € |
| Mini triangular scraper FT11001 | | |
|  | fixed HSS blade D50 with handle | 0 413 962 17.85 € |
| Mini hole deburring head FT12001 | | |
|  | with rotatably-mounted Ø 3.2 mm counterbore in handle | 0 413 963 14.45 € |

↓ matching set

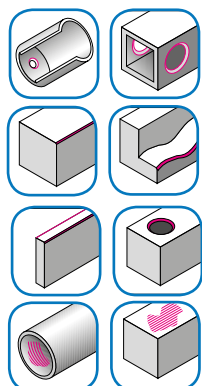







| | Order No. | Price from 1 set |
|---|--|--------------------------|
| Set mini deburrer FT3000, 3 parts | | |
|  | Contents of the plastic box: 1 x mini deburrer FT10001 with fixed HSS blade S150 with handle 1 x mini triangular scraper FT11001, with fixed HSS blade D50 in handle 1 x mini hole deburring head FT12001, with rotatably mounted Ø 3.2 mm counterbore in handle (the blades are non-replaceable) | 0 413 964 40.80 € |

Deburring tools

| | Order No. | Price from 1 piece |
|---|------------------|-----------------------|
| Universal deburrer with aluminium handle | | |
| incl. one blade (S 10) | 0 413 916 | 9.70 € |









⚙️ Accessories / spare parts

| | Packing quantity | Order No. | Price from 1 pack |
|---|-----------------------------------|-----------|--------------------------|
| Universal deburrer with aluminium handle, matching replacement blades | | | |
|   | S10 (BS1010), HSS, PU = 10 pieces | 10 pieces | 0 413 937 19.70 € |
|   | S150 (BK3010) for bore Ø 1.5 mm | 10 pieces | 0 413 942 25.90 € |
|   | | | |

| | Order No. | Price from 1 piece | 5 pieces |
|---|--|--------------------------|----------|
| Hand deburrer, 90° countersink | | | |
|  | for 3 - 20 mm bore diameter, telescopic receptacle | 0 413 915 34.55 € | 32.90 € |

⚙️ Accessories / spare parts

| | Order No. | Price from 1 piece | 5 pieces |
|---|---|-----------------------|----------|
|   | Handle NG-3 | | |
|  | 0 413 923 | 10.00 € | 9.60 € |
|  | Telescopic holder, type C | | |
| suitable for the countersink attachments C12, C20 and C30 | 0 413 924 | 8.55 € | 8.25 € |
|  | Countersink attachment 90°, type C12 for 1 - 12 mm bore diameter | | |
| suitable for telescopic receptacle type C | 0 413 925 | 18.85 € | 17.95 € |
|  | Countersink attachment 90°, type C20 for 3 - 20 mm bore diameter | | |
| | 0 413 926 | 25.05 € | 23.80 € |
|  | Countersink attachment 90°, type C30 for 3 - 30 mm bore diameter | | |
| | 0 413 927 | 40.10 € | 38.25 € |



Deburring tools

| | Order No. | Price from |
|---|------------------|------------|
| | | 1 piece |
| Universal handle with triangular scraper | 0 413 917 | 14.05 € |

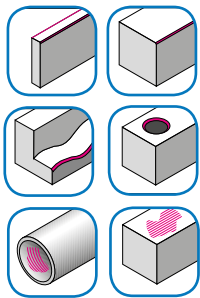

⚙️ Accessories / spare parts







| | Dimensions | Order No. | Price from |
|---|-------------|------------------|------------------|
| | | | 1 piece 5 pieces |
| Universal handle | | 0 413 939 | 6.95 € 6.60 € |
|  for receiving deburring tools, needle files, etc. Flexible collet with a clamping range of between 2.2 and 4.5 mm | | | |
| Spare double blade T80 | | 0 413 953 | 14.05 € |
|  HSS, 4.2 x 80 mm, 60°, hardness 62 - 64 HRC | 4,2 x 80 mm | | |

| | Order No. | Price from |
|--|------------------|------------------|
| | | 1 piece 5 pieces |
| Triangular scraper with telescopic receptacle | 0 413 912 | 21.55 € 20.50 € |
| incl. blade (Ø 2.5 x 50 mm) | | |

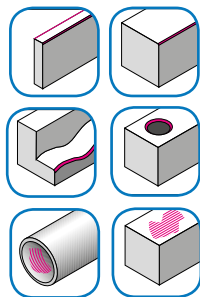

⚙️ Accessories / spare parts





| | Packing quantity | Order No. | Price from |
|--|------------------|------------------|---------------------------------|
| | | | 1 piece 1 pack 5 pieces 5 packs |
| Handle NG-3 | | 0 413 923 | 10.00 € 9.60 € |
|  | | | |
| Blade holder suitable for blades of Ø 2.5 mm | | 0 413 918 | 8.70 € 8.45 € |
|  with clamping screw (Ø 3 mm) for fixing the blade | | | |
| Replacement blades | | 0 413 951 | 97.35 € 92.85 € |
|  D50, triangular, Ø 2.5 x 50 mm, hardness 62 - 64 HRC, PU = 10 pieces | 10 pieces | | |

Deburring tools

| | Order No. | Price from | |
|--|------------------|------------|----------|
| | | 1 piece | 5 pieces |
| Triangular scraper, adjustable with aluminium handle | | | |
|  incl. double blade (Ø 4.2 x 80 mm) | 0 413 913 | 23.90 € | 22.80 € |

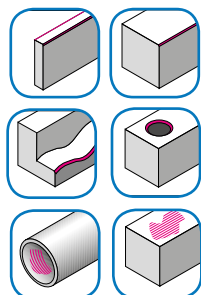
Accessories / spare parts



| | Order No. | Price from | |
|---|--------------------|------------|----------|
| | | 1 piece | 5 pieces |
| Spare double blade T80 | | | |
|  HSS, 4.2 x 80 mm, 60°, hardness 62 - 64 HRC | 0 413 953 | 14.05 € | |
| Aluminium universal handle | | | |
|  12 mm hexagonal, variable tool receptacle | 0 413 913-2 | 15.60 € | 14.85 € |

| | Order No. | Price from | | |
|--|------------------|------------|----------|-----------|
| | | 1 piece | 5 pieces | 10 pieces |
| High precision plier JGH-SPN-120 | | | | |
| <ul style="list-style-type: none"> • for cleanly removing injection points, burrs, etc. • no crushing, clean cut edge owing to specially ground and shaped cutting edges | 0 413 955 | 64.10 € | 60.90 € | 57.85 € |

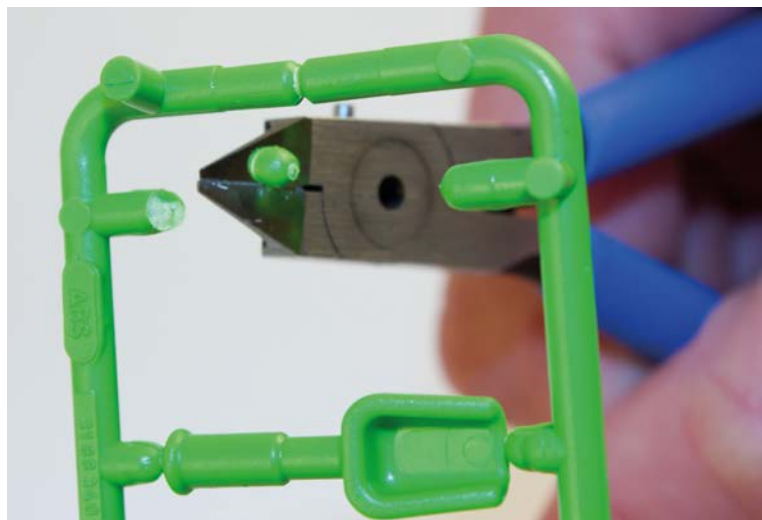

Deburring tools Set deburrer

| | Order No. | Price from | |
|--|------------------|------------|---------|
| | | 1 set | 5 set |
| Set with accessories | | | |
|  Contents: handle, 10 blades and telescopic receptacle (adjustable from 30 to 115 mm) | 0 413 914 | 24.45 € | 23.30 € |

⚙️ Accessories / spare parts

| | Packing quantity | Order No. | Price from |
|---|------------------|------------------|------------|
| | | | 1 pack |
| Universal deburrer with aluminium handle, matching replacement blades | | | |
|  S10 (BS1010), HSS, PU = 10 pieces | 10 pieces | 0 413 937 | 19.70 € |
| S150 (BK3010) for bore Ø 1.5 mm | 10 pieces | 0 413 942 | 25.90 € |

| | Order No. | Price from | |
|---|------------------|------------|----------|
| | | 1 set | 5 set |
| Deburring set in storage case | | | |
|  Set consisting of: 1 x Hand deburrer, specially for deburring longitudinal grooves, (groove width 2.4 - 11 mm), with handle (order no. 0 413 933) 1 x Hand deburrer, for deburring 2 edges simultaneously (material width 1 - 8 mm), V-shaped blade, with handle (order no. 0 413 932) 1 x Hand deburrer, triangular scraper with 2.5 x 50 mm blade, telescopic receptacle (order no. 0 413 912) 1 x Hand deburrer, 90° countersink for 3 - 20 mm bore diameter, telescopic receptacle (order no. 0 413 915) 1 x Hand deburrer for deburring bores 1 x Hand deburrer for brass and cast iron, for interior and exterior (40° and 60° blade) Case dimensions: approx. 270 x 230 x 50 mm | 0 413 934 | 136.40 € | 132.80 € |