

AUTOFRENANTI DOPPIO FRENO - *SELF-BRAKING DOUBLE BRAKE*

 **NERIMOTORI**
Experience the power

La sicurezza dell'azione frenante per una più affidabile e sicura fermata in caso di guasto e/o interruzione dell'alimentazione.

Safe braking action for more reliable and safer stopping in the event of a breakdown and/or a power failure.

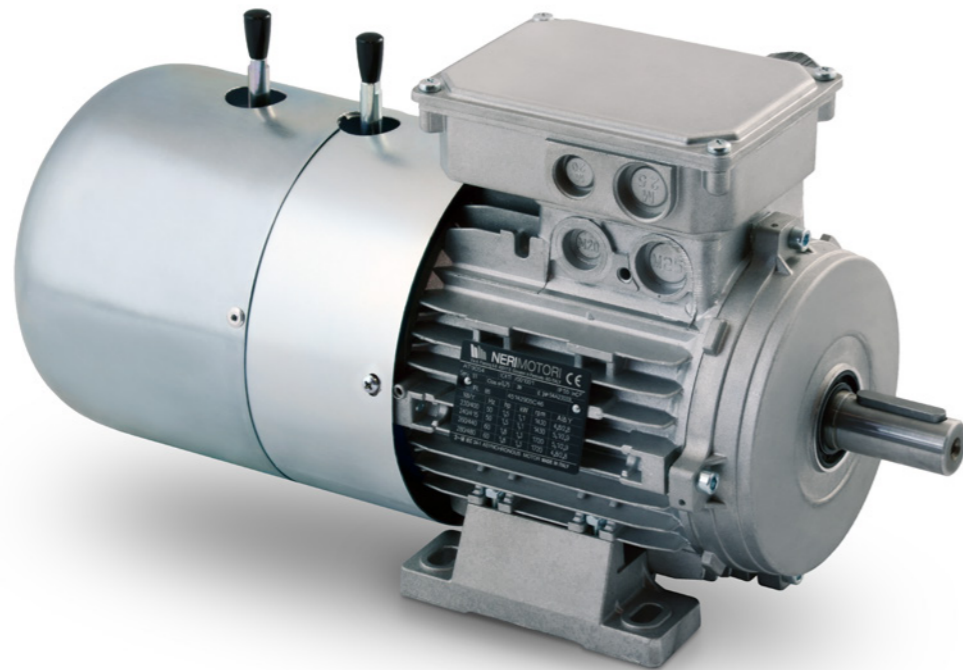

- Doppio freno e doppia leva di sblocco
- Ridondanza elettro-meccanica
- Più affidabilità nell'arresto

- *Double brake and double release lever*
- *Electro-mechanical redundancy*
- *More reliable stopping*

Eccellenza elettro-meccanica

L'elevata coppia di frenatura è disponibile a freno non alimentato. Il freno viene sbloccato elettromagneticamente o mediante le leve di sblocco in caso di emergenza.

Electro-mechanical excellence

High braking torque is available with a non-powered brake. The brake can be released either electromagnetically or using the release levers in the event of an emergency.



Vantaggi

- Ridondanza elettro-meccanica
- Elevata coppia di stazionamento (da 12 a 800 Nm)
- Sblocco manuale e alimentazione del freno separata di serie
- Grado di protezione standard IP54, (su richiesta IP55 o IP65)
- Possibilità di avere coppie frenanti minorate o maggiorate
- Rumorosità sotto i limiti imposti dalle Direttive Comunitarie.
- Possibilità di soluzioni personalizzate

Advantages

- *Electro-mechanical redundancy*
- *High holding torque (from 12 to 800 Nm)*
- *Brake manual release and separate power supply as standard*
- *Standard IP54 protection rating, (IP55 or IP65 on request)*
- *Option of increased or decreased braking torques*
- *Noise level below the limits set by EC Directives*
- *Customized solutions are available*



Il valore aggiunto del doppio freno

The added value of a double brake

Settori di applicazione:

Areas of application:



Teatrali o Palcoscenico
Stage machinery



Ascensori o impianti di sollevamento
Cranes



Montacarichi o magazzini automatici
Hoists or storage technology



Scale mobili o sollevatori
Escalators

CARATTERISTICHE TECNICHE - TECHNICAL SPECIFICATIONS

Grandezza / Size	IEC63 ÷ IEC 200
Tensione freni / Brakes voltage	24, 103, 180, 205 VDC
Grado di protezione freni / Protection index brakes	IP54 (IP55 o IP65 su richiesta)
Ventilazione motore / Motor ventilation	IC411 (IC410, IC416, IC418 su richiesta / other on request)
Opzionale / Optional	Equipaggiati o solo Predisposti per Encoder, uso per Inverter, sensori di usura ferodo, esecuzioni meccaniche speciali in genere / Equipped or only set-up for Encoders, use for Inverters, lining wear sensors, special mechanical executions in general.
Certificazione/ Certification	CE (UL-CSA e GOST-R su richiesta)

CARATTERISTICHE ELETTRO-MECCANICHE FRENO / BRAKE ELECTRO-MECHANICAL FEATURES

IEC	Freno di manovra Standard brake (Nm)	Freno di stazionamento con frenata di emergenza fino a Holding brake with emergency stop up to (Nm)	Pn (W)	Sheu (1/h)
63	4x2	6x2	20x2	79
71	4x2	6x2	20x2	79
80	8x2	12x2	25x2	50
90	16x2	23x2	30x2	40
100	32x2	46x2	40x2	30
112	60x2	80x2	50x2	28
132	80x2	125x2	55x2	27
160	150x2	235x2	85x2	20
180	260x2	400x2	100x2	19
200	260x2	400x2	100x2	19

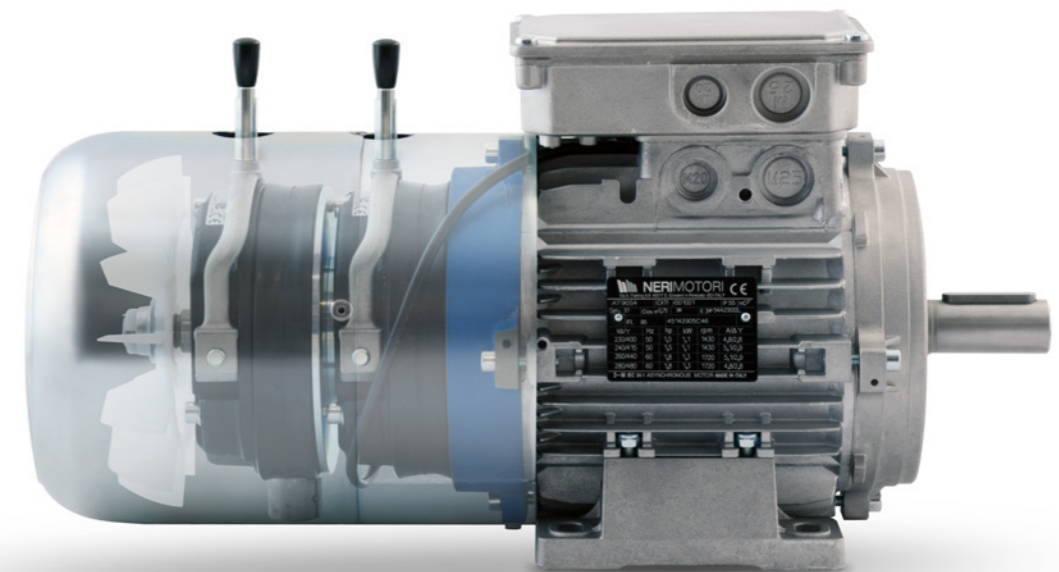



B3

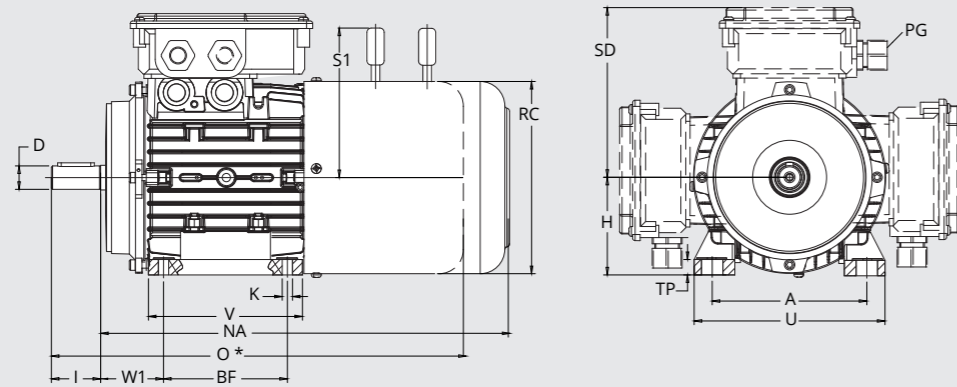

Grand. Size	Dimensioni / Dimensions															B3
	D	I	A	BF	U	V	K	TP	W1	RC	H	SD	PG	NA	O*	
63	11	23	100	80	120	105	7	10	41	123	63	110	M16	280**	245	98
71	14	30	112	90	136	108	8	11	48	137	71	117	M16	301**	251	98
80	19	40	125	100	154	125	9	13/14	51	156	80	137	M20	338	295	111
90S	24	50	140	100	170	130	10	13/15	57,5	176	90	147	M20	359	319	129
90L	24	50	140	125	170	155	10	13/15	57,5	176	90	147	M20	384	344	129
100	28	60	160	140	192	175	13	15/16	63	194	100	155	M20	452	386	139
112	28	60	190	140	224	176	13	15	71	218	112	168	M20	507	424	161
132S	38	80	216	140	260	180	14	16/18	89,5	258	132	188	M32	522	481	186
132M	38	80	216	178	260	218	14	16/18	89,5	258	132	188	M32	560	519	186
160M	42	110	254	210	318	260	16	18	110	309	160	246	M32	705**	616	242
160L	42	110	254	254	318	304	16	18	110	309	160	246	M32	750**	661	242
180	48	110	280	280	346	330	16	24	128,5	346	180	260	M32	922**	740	320

B5

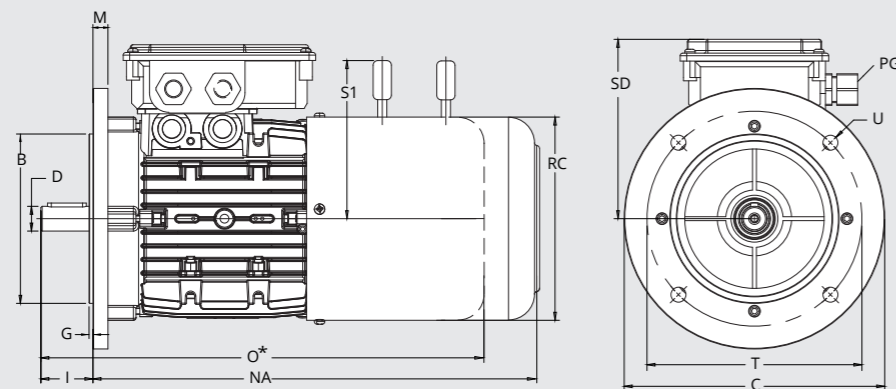

Grand. Size	Dimensioni / Dimensions														B5
	D	I	B	C	G	M	T	U***	RC	SD	PG	NA	O*	S1	
63	11	23	95	140	2,5	10	115	9,5	123	110	M16	280**	245	98	
71	14	30	110	160	3	10	130	9,5	137	117	M16	301**	251	98	
80	19	40	130	200	3	11	165	12	156	137	M20	338	295	111	
90S	24	50	130	200	3,5	10	165	12	176	147	M20	359	319	129	
90L	24	50	130	200	3,5	10	165	12	176	147	M20	384	344	129	
100	28	60	180	250	4	14	215	14,5	194	155	M20	452	386	139	
112	28	60	180	250	4	14	215	14,5	218	168	M20	507	424	161	
132S	38	80	230	300	4	20	265	14,5	258	188	M32	522	481	186	
132M	38	80	230	300	4	20	265	14,5	258	188	M32	560	519	186	
160M	42	110	250	350	5	20	300	18,5	309	246	M32	705**	616	242	
160L	42	110	250	350	5	20	300	18,5	309	246	M32	750**	661	242	
180	48	110	250	350	5	20	300	19	346	260	M32	922**	740	320	

B14

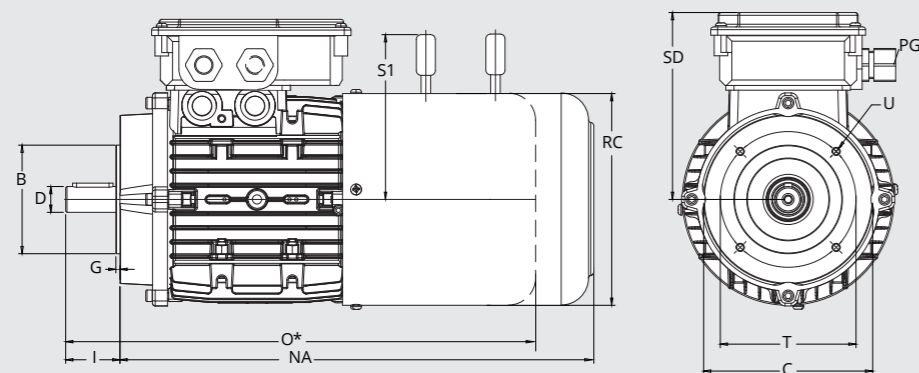

Grand. Size	Dimensioni / Dimensions													B14
	D	I	B	C	G	T	U	RC	SD	PG	NA	O*	S1	
63	11	23	60	90	2,5	75	M5	123	110	M16	280**	245	98	
71	14	30	70	105	3	85	M6	137	117	M20	301**	251	98	
80	19	40	80	120	3	100	M6	156	137	M20	338	295	111	
90S	24	50	95	140	3	115	M8	176	147	M20	359	319	129	
90L	24	50	95	140	3	115	M8	176	147	M20	384	344	129	
100	28	60	110	160	4	130	M8	194	155	M20	452	386	139	
112	28	60	110	160	4	130	M8	218	168	M32	507	424	161	
132S	38	80	130	200	4	165	M10	258	188	M32	522	481	186	
132M	38	80	130	200	4	165	M10	258	188	M32	560**	519	186	
160M	42	110	180	250	4	215	M12	309	246	M32	705**	616	242	
160L	42	110	180	250	4	215	M12	309	246	M32	750**	661	242	

I dati contenuti in questa brochure sono indicativi e non impegnativi per l'azienda.
 All data contained in this brochure are purely indicative and not binding for our company.

O* = Senza ventola e senza copriventola / Without fan and fan cover

NA** = le quote potrebbero subire variazioni, per informazioni contattare l'ufficio tecnico di NeriMotori / measurements may vary, for more information contact the NeriMotori Technical Office.

U*** ± 0,5 tolleranza / ± 0,5 tolerance



Made in Italy EU



Legal Head Office: Via A. Fleming 6-8 | Operations & Logistics: Via A. Fleming, 10
40017 S. Giovanni in Persiceto (BO) Italy | Tel. +39 0516870911
info@nerimotori.com | www.nerimotori.com