



## NENUTEC WATER - NBFV 8000 SERIES

(MOTORISED) BUTTERFLY VALVES WAFER TYPE 2-WAY FLANGED



### NBFV 8000 SERIES

NENUTEC Butterfly valves are especially designed and produced for applications in the HVAC systems.

Our wide range of NENUTEC Butterfly valves has been developed for use in LPW (low pressure water) heating and air condition systems.

#### Butterfly valves:

- DN... sizes up to DN 150 mm /6" inch
- Low weight and dimension
- Easy disassembly and assembly
- Low pressure drop
- Automatic regulation

#### Actuator:

- NEA.../FSA... 16 / 24 / 32 Nm torque  
Refer to actuator data sheets
- Power Supply AC/DC 24 V and AC 230 V
- Control 2 Point, 2 / 3 point or modulating
- Bracket / mounting connection butterfly body
- 2 adjustable auxiliary switches (SPDT)
- NENUTEC actuators can be factory or field installed

Pictures might not correspond with technical data.

#### TECHNICAL SPECIFICATIONS

Service	chilled, hot water, up to 50% glycol solutions
Fluid temperature limits	water: -5° C...+120° C
Ambient operating temperature	-20° C...+50° C
Non-operating temperature	-30° C...+60° C
Valve body pressure / temperature rating	Water: 1.6 MPa(PN16)
Maximum closeoff pressure	0.35 MPa
Maximum operating pressure drop	232 psi (1.599 kPa)
Leakage	0.01% of Kvs (maximum flow) Port
Pipe connection	Flange PN 10 - 16 to EN 1092/1
Flange	PN 10 - 16 ANSI 150
Materials	body: Aluminium; optional Modular Iron Shaft: x 30 Cr13 SS420 Dics: Modular Iron GJS 500; optional Stainless Steel SS 386 Seat: EPDM



## Model Selection Table Butterfly Valves

DN (mm)	DN (Inch)	$\Delta p$	Model	Kvs	Weight (kg)	Connection	Actuator type
40	1 1/2"	12 bar	NBFV 840	50	2.25	PN 10/16	NEA.../FSA...16
50	2"	10 bar	NBFV 850	85	3.00	PN 10/16	NEA.../FSA...16
65	2 1/2"	8 bar	NBFV 865	215	3.70	PN 10/16	NEA.../FSA...16
80	3"	8 bar	NBFV 880	420	4.00	PN 10/16	NEA.../FSA...16
100	4"	6 bar	NBFV 8100	800	5.25	PN 10/16	NEA.../FSA...24
125	5"	6 bar	NBFV 8125	1010	7.50	PN 10/16	NEA.../FSA...24
150	6"	4 bar	NBFV 8150	2100	8.90	PN 10/16	NEA...32

## Dimension of Butterfly body assembled with actuator / Different pressure (bar)

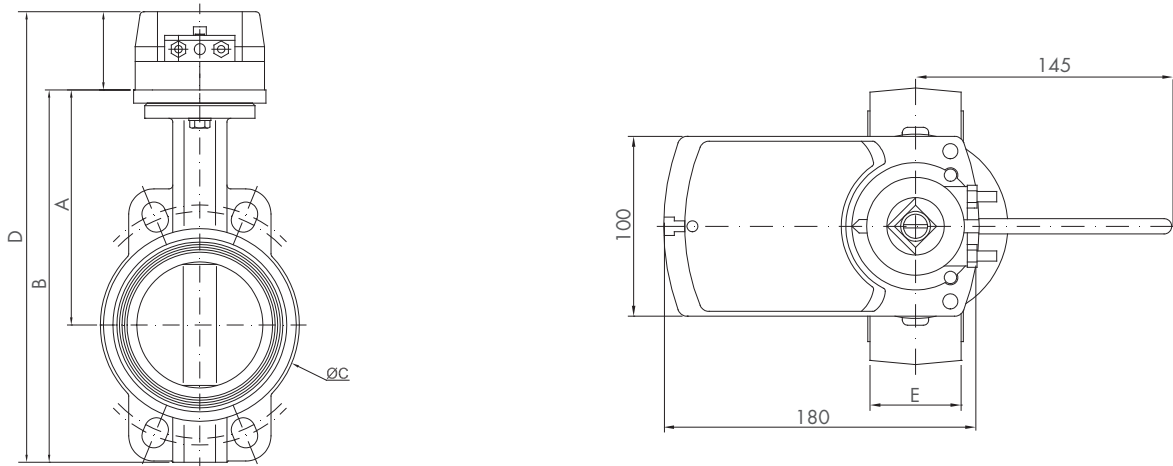

### ⚠ IMPORTANT REMARKS

This actuator includes electrical and electronic components and may not be disposed as household garbage. Please consider the local valid legislation. 

Consult NENUTEC representatives for specific requirements and material selections for your intended application. The entire content of this technical datasheet is protected by copyright with all rights reserved ©.

The performance specifications are nominal and conform to acceptable industry standards. NENUTEC shall not be liable for damages resulting from misapplication or misuse of its products.

### Dimensions of valve body (mm)

Model Type	A	B	C	D	E
NBFV 840	151	217	83	284	33
NBFV 850	166	239	104	306	43
NBFV 865	172	258	121	325	46
NBFV 880	170	260	132	327	46
NBFV 8100	187	295	154	362	52
NBFV 8125	205	324	189	391	56
NBFV 8150	217	349	218	416	56

#### NENUTEC AG

Schachenstrasse 80  
 CH - 8645 Jona/SG - Switzerland  
 T: +41 55 224 40 60  
 F: +41 55 224 40 69  
 www.nenutec.com

#### Distributor

#### Distributor