

CMOS Camera DDU Series

DDU1607MG DDU1607MCG/DDU1607MCF

Specifications

Toshiba Teli Corporation

Information contained in this document is subject to change without prior notice.
Standard name might be trade mark of each company.

DAA01394C

Contents

RESTRICTION FOR USE	2
CASES FOR INDEMNITY (LIMITED WARRANTY)	3
USAGE PRECAUTIONS.....	4
1. Overview	6
2. Features	6
3. Configuration.....	8
4. Optional part.....	8
5. Functions.....	9
6. Specifications	18
7. Timing chart.....	33
8. Warranty rules.....	36
9. Repair.....	37
10. Outline Drawing.....	38

RESTRICTION FOR USE

- Should the equipment be used in the following conditions or environments, give consideration to safety measures and inform us of such usage:
 - (1) Use of the equipment in the conditions or environment contrary to those specified, or use outdoors.
 - (2) Use of the equipment in applications expected to cause potential hazard to people or property, which require special safety measures to be adopted.
- This product can be used under diverse operating conditions. Determination of applicability of equipment or devices concerned shall be determined after analysis or testing as necessary by the designer of such equipment or devices, or personnel related to the specifications. Such designer or personnel shall assure the performance and safety of the equipment or devices.
- This product is not designed or manufactured to be used for control of equipment directly concerned with human life (*1) or equipment relating to maintenance of public services/functions involving factors of safety (*2). Therefore, the product shall not be used for such applications.
 - (*1): Equipment directly concerned with human life refers to.
 - Medical equipment such as life-support systems, equipment for operating theaters.
 - Exhaust control equipment for exhaust gases such as toxic fumes or smoke.
 - Equipment mandatory to be installed by various laws and regulations such as the Fire Act or Building Standard Law
 - Equipment related to the above
 - (*2): Equipment relating to maintenance of public services/functions involving factors of safety refers to.
 - Traffic control systems for air transportation, railways, roads, or marine transportation
 - Equipment for nuclear power generation
 - Equipment related to the above

CASES FOR INDEMNITY (LIMITED WARRANTY)

We shall be exempted from taking responsibility and held harmless for damage or losses incurred by the user in the following cases.

- Natural disasters, such as an earthquake and thunder, fire or any other act of God; acts by third parties; misuse by the user, whether intentional or accidental; use under extreme operating conditions.
- In the case of indirect, additional, consequential damages (loss of business interests, suspension of business activities) are incurred as result of malfunction or non-function of the equipment, we shall be exempted from responsibility for such damages.
- In the case damage or losses are caused by failure to observe the information contained in the instructions in this instruction manual and specifications.
- In the case damage or losses are caused by use contrary to the instructions in this instruction manual and specifications.
- In the case damage or losses are caused by malfunction or other problems resulting from use of equipment or software that is not specified.
- In the case damage or losses are caused by repair or modification conducted by the customer or any unauthorized third party (such as an unauthorized service representative).
- Expenses we bear on this product shall be limited to the individual price of the product.
- The item that is not described in specifications of this product is off the subject of the guarantee.
- The attachment mistake of a cable.

USAGE PRECAUTIONS

● Handle carefully

Do not drop the equipment or allow it to be subject to strong impact or vibration, as such action may cause malfunctions. Further, do not damage the connection cable, since this may cause wire breakage.

● Environmental operating conditions

Do not use the product in locations where the ambient temperature or humidity exceeds the specifications.

Otherwise, image quality may be degraded or internal components may be adversely affected. In particular, do not use the product in areas exposed to direct sunlight.

● Combination of C-mount lens

Depending on the lens you use, the performance of the camera may not be brought out fully due to the deterioration in resolution and brightness in the peripheral area, occurrence of a ghost, aberration and others. When you check the combination between the lens and camera, be sure to use the lens you actually use.

When installing a lens in the camera, make sure carefully that it is not tilted.

In addition, use a mounting screw free from defects and dirt. Otherwise, the camera may be unable to be removed.

As for the C-mount lens used combining this product, the projection distance from bottom of the screw should use 8mm or less.

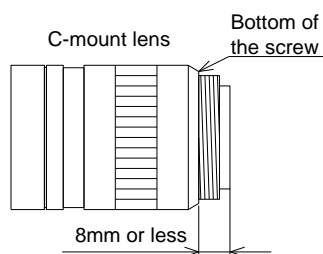

● Mounting to a pedestal

When mounting this product to a pedestal, make sure carefully that the lens doesn't touch with the pedestal.

● Do not expose the camera's image-pickup-plane to sunlight or other intense light directly.

Its inner CMOS sensor might be damaged.

● Occurrence of moiré

If you shoot thin stripe patterns, moiré patterns (interference fringes) may appear. This is not a malfunction.

● Occurrence of noise on the screen

If an intense magnetic or electromagnetic field is generated near the camera or connection cable, noise may be generated on the screen. If this occurs, move the camera or the cable.

USAGE PRECAUTIONS

- **Handling of the protective cap**

If the camera is not in use, attach the lens cap to the camera to protect the image pickup surface.

- **If the equipment is not to be used for a long duration**

Turn off power to the camera for safety.

- **Maintenance**

Turn off power to the equipment and wipe it with a dry cloth.

If it becomes severely contaminated, gently wipe the affected areas with a soft cloth dampened with diluted neutral detergent. Never use alcohol, benzene, thinner, or other chemicals because such chemicals may damage or discolor the paint and indications.

If the image pickup surface becomes dusty, contaminated, or scratched, consult your sales representative.

- **Disposal**

When disposing of the camera, it may be necessary to disassemble it into separate parts, in accordance with the laws and regulations of your country and/or municipality concerning environmental contamination.

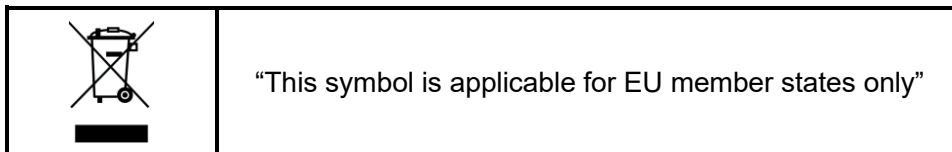

[Phenomena specific to CMOS sensor]

- **Defective pixels**

A CMOS image sensor is composed of photo sensor pixels in a square grid array. Due to the characteristics of CMOS image sensors, over- or under-driving of the pixels results in temporary white or black areas (as if these are noises) appearing on the screen. This phenomenon, which is not a defect is exacerbated under higher temperatures and long exposure time.

- **Image shading**

The brightness of the upper part of the screen may be different from that of the lower part. Note that this is a characteristic of a CMOS image sensor and is not a fault.

1. Overview

DDU1607M series is an integrated-(one-body)-type camera that adopts a global shutter CMOS sensor. DDU1607M adopts a 16M B&W type 1.1 sensor. Suffix [C] are attached to the color models. For video output and camera control, the USB 3.1 Gen1 (USB3.0) interface standard is adopted for high transfer rate, and it is easy to integrate into industrial equipment.

2. Features

2.1 High frame rate

Supporting high frame rate of 16 M pixels 47 fps by outputting images with two USB 3.0 cables.

2.2 Global shutter

As it employs a global electronic shutter similar to a CCD image sensor, clear images of even fast-moving object are obtainable with less blur.

2.3 USB 3.1 Gen1 (USB3.0) interface

Video output and camera control are performed via the two USB 3.1 Gen1 (USB3.0) standard interfaces. Data transfer is up to 10Gbps (5Gbps x 2) that enables to output uncompressed video data at high frame rate.

2.4 USB3 Vision

This product is based on USB3 Vision Ver.1.0.

2.5 GenICam Ver.2.4 and Ver.3.0

This product is based on GenICam Generic Interface for Cameras Ver.2.4 and Ver.3.0.

2.6 IIDC2 Digital Camera Control Specification Ver.1.1.0

This product is based on IIDC2 Digital Camera Control Specification Ver.1.1.0.

2.7 e-CON Connector adoption

The e-CON connector adoption enables to assemble the cable easily without using special tools.

2.8 Random Trigger Shutter

The Random Trigger Shutter function provides images in any timing by input of an external trigger signal. Trigger control from PC is available as well.

2.9 Scalable

Selectable video output area. This mode achieves higher frame rate by reducing vertical output area. And reduces occupied data rate of USB bus by reducing horizontal output area.

2.10 Binning

Pixel data is combined by vertical and horizontal.

2.11 Decimation

Camera reads all effective areas at high speed by skipping lines.

2.12 Dust-proof Glass

Dust-proof Glass is built in default.

Suffix [G] is attached to the model name of built-in Glass.

2.13 Compact and lightweight

This camera is compact and lightweight; it is easy to integrate into industrial equipment.

2.14 IR –cut filter

Build-in IR-cut filter models are optional for color models.

Suffix [F] is attached to the model name of built-in IR-cut filter model.

3. Configuration

(1) Camera body

* No application software and manuals are attached to this camera.

4. Optional part

- Camera mounting kit Model name: CPTC6M

* Contact your dealer / distributor for details of option units.

5. Functions

5.1 Gain

Manual gain and automatic gain control (AGC) settings are provided. Gain is adjustable from 1 to +8times.

5.1.1 Manual

The camera gain can be set manually.

5.1.2 AGC

The camera gain is automatically adjusted to suit subject brightness.

Notes on gain setting:

Setting the gain value too high increases noises. When you adjust the brightness of the image, I ask you to have final image quality checked with your environment.

5.2 Black Level

Black level is adjustable from -25% to +25% as white saturation level is 100%.

5.3 Gamma

Gamma correction curve is adjustable from 0.45 to 1.

5.4 LUT (Look up Table)

Arbitrary curve and binarization are possible by using 12 bit input and 12 bit output LUT.

5.5 Exposure Time

Manual exposure time and automatic exposure time control (AE) are available

5.5.1 Manual

Exposure time is adjustable by micro-second unit.

5.5.2 AE

The exposure time is adjusted automatically to suit subject brightness.

This mode can also operate with AGC (Automatic Gain Control) to automatically adjust fluctuations in subject brightness across a wide range (ALC operation).

5.6 White balance

Color models have three white balance modes, Manual White Balance (MWB) and One-Push auto White Balance (OPWB). Select the mode to suit the subject and purpose.

5.6.1 MWB

R/B gain can be set independently.

5.6.2 OPWB

When OPWB is executed, the camera adjusts R/B gain automatically.

5.7 Sharpness

It is possible to adjust the edge enhancement of the image.

5.8 Chunk

It is possible to integrate some sort of information about each image with video data.

5.9 Random Trigger Shutter

An image is captured at the desired timing using trigger signal input. External trigger signal from I/O connector and software trigger from control command via the USB 3.1 Gen1 interface are available (Edge mode / Bulk mode). Trigger polarity is selectable (High active / Low active).

Note that Random Trigger Shutter will cause a delay between trigger signal and start of exposure. See 7. Timing Chart for detail.

- Edge mode (TriggerSequence0)

The exposure time is determined by Exposure Time setting.

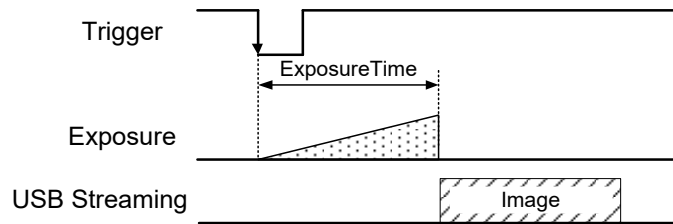

- Level mode (TriggerSequence1)

The exposure time is determined by the pulse width of the trigger signal.

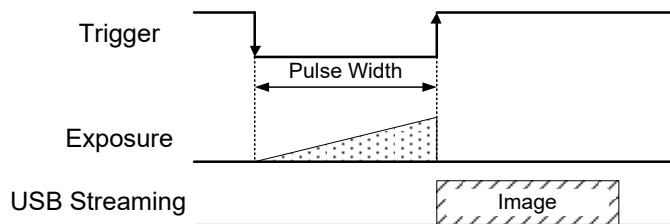

- Bulk mode (TriggerSequence6)

Camera exposes and transfers multiple frames by a single trigger.

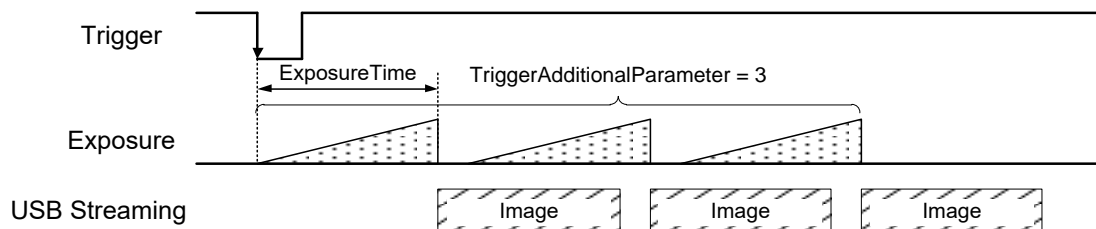

Notes on Random Trigger Shutter :

- In the period when FrameTriggerWait signal is inactive, user must not input external trigger signal to this camera.
- When the interval of the input trigger signal is extremely short, or when the trigger signal is noisy, there is a possibility of causing the malfunction. In this case, please input a proper trigger signal.

5.10 Sequential Shutter

Sequential Shutter function performs sequential capturing with applying the settings of UserSet that have been made entry in advance.

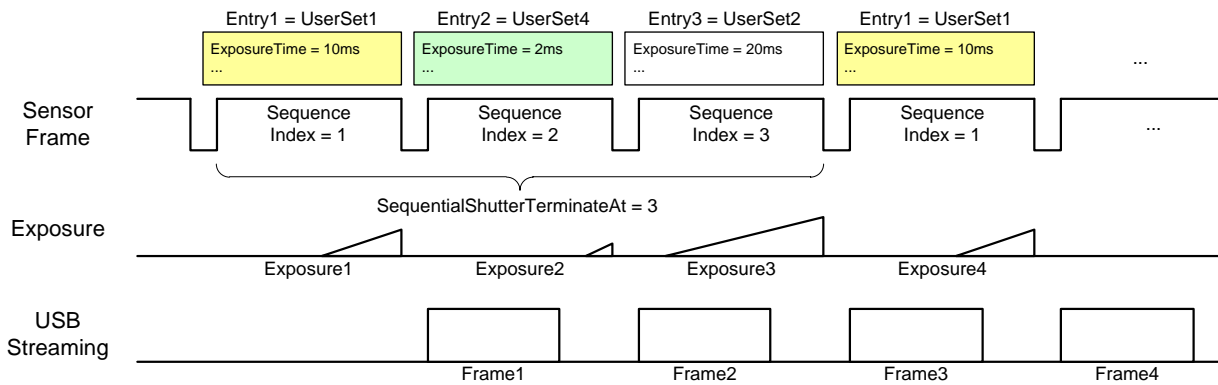

Note on Sequential Shutter:

- In Sequential Shutter mode, window size is unchangeable.

5.11 Trigger Delay

You can add the delay between trigger signal input and the start of exposure.

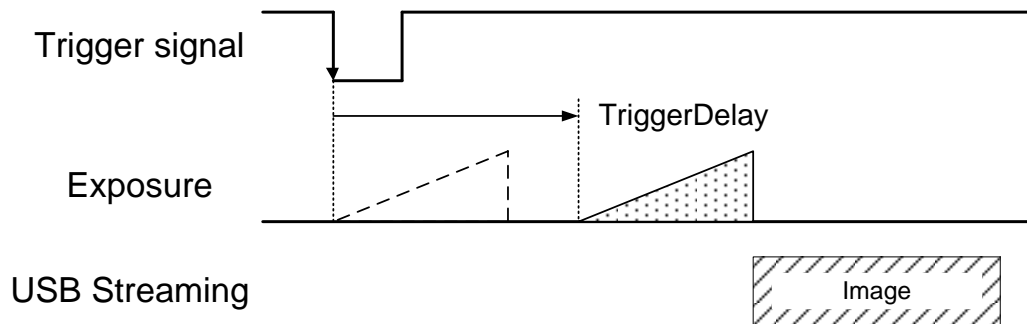

5.12 AntiGlitch – AntiChattering

AntiGlitch and AntiChattering functions filter noise and unstable state of the digital input (trigger signal).

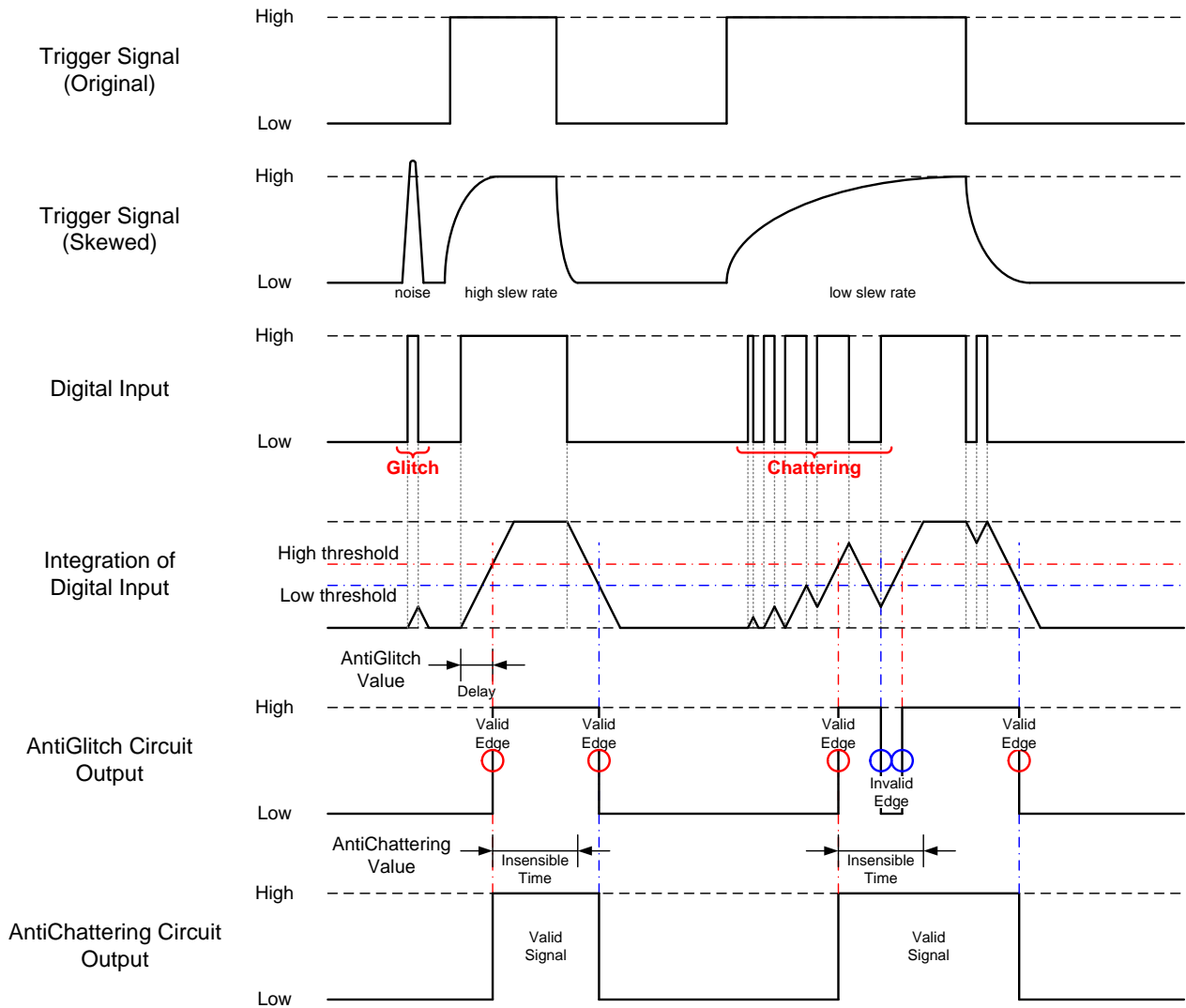

5.13 Event

Camera notifies FrameTrigger status and other information by USB3 Vision Event Packet.

- FrameTrigger : Reception of Frame Start Trigger
- FrameTriggerError : Rejection of Frame Start Trigger
- FrameTriggerWait : Start of waiting for Frame Start Trigger
- FrameTransferStart : Start of transferring streaming data
- FrameTransferEnd : End of transferring streaming data
- ExposureStart : Start of Exposure
- ExposureEnd : End of Exposure
- Timer0Start : Start of Timer0
- Timer0End : End of Timer0

Events timing are as following chart.

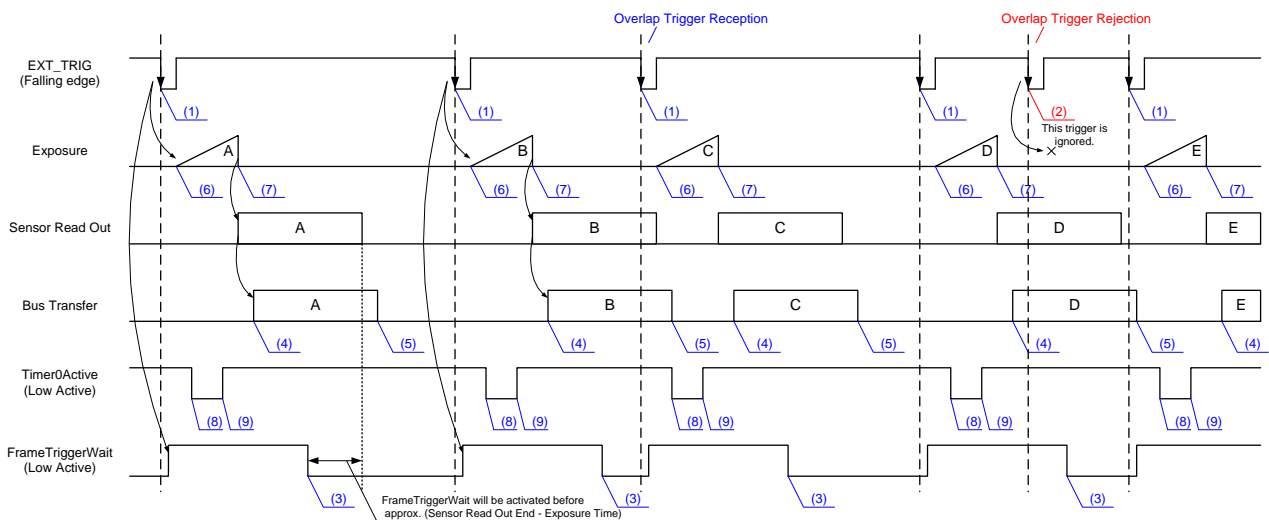

Event Name

- (1) FrameTrigger : Reception of Frame Start Trigger.
- (2) FrameTriggerError : Rejection of Frame Start Trigger.
- (3) FrameTriggerWait : Start of waiting for Frame Start Trigger.
- (4) FrameTransferStart : Start of transferring streaming data.
- (5) FrameTransferEnd : End of transferring streaming data.
- (6) ExposureStart : Start of Exposure.
- (7) ExposureEnd : End of Exposure.
- (8) Timer0Start : Start of Timer0.
- (9) Timer0End : End of Timer0.

5.14 GPIO

Selected signals are output from GPIO pins of I/O connector. Following signals are selectable. Output signal is 5V CMOS output and open collector output.

- Timer0 Active : This signal can be used as strobe control signal.
The delay time and pulse width of this signal are configurable.
- User Output : Level selectable user output by register setting.
- ExposureActive : Period from exposure start to end.
- FrameActive : Period from exposure start to the CMOS transfer completion.
- FrameTransfer : Period of transferring image data on USB bus.
- FrameTriggerWait : Indicating waiting a Random Trigger Shutter.
An External trigger is input during this period,
exposure starts immediately.

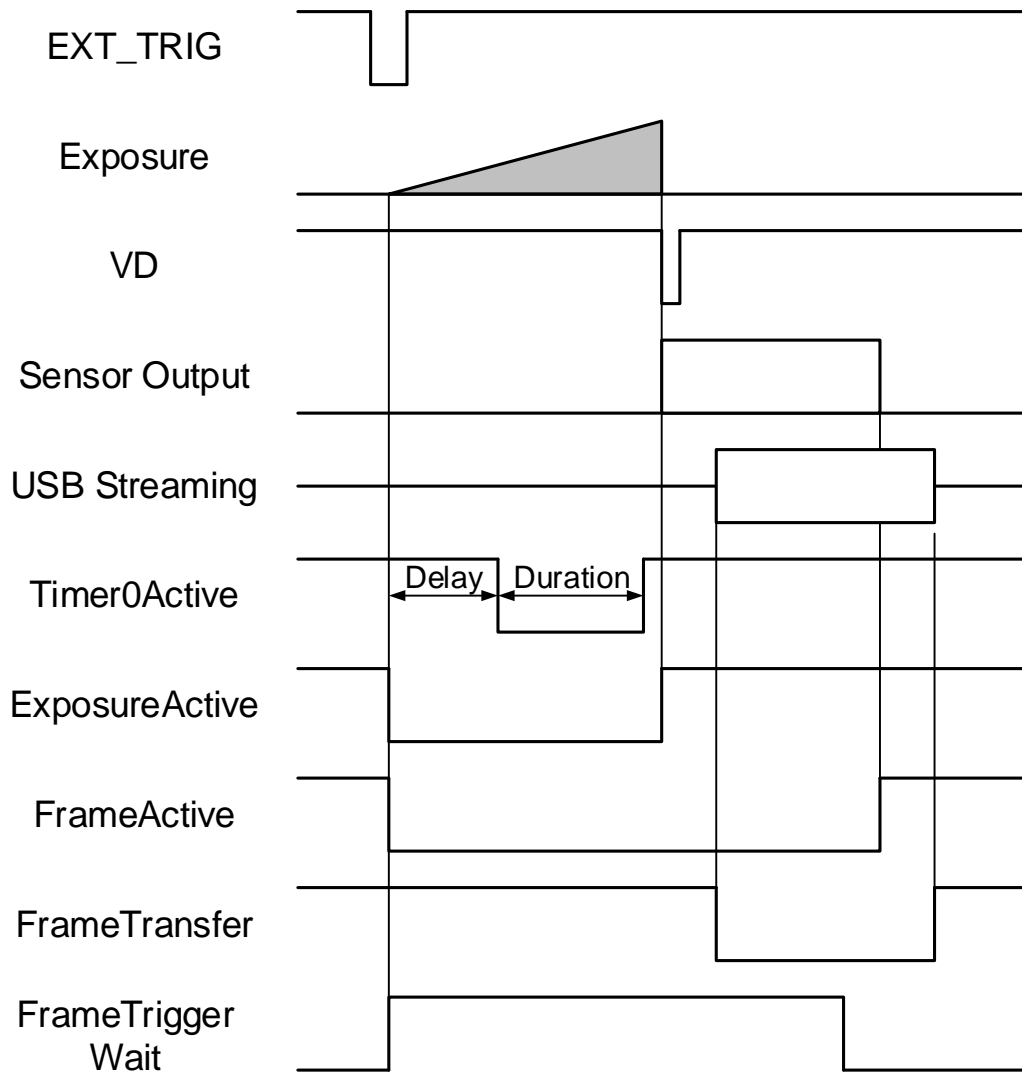

* ActiveLow

5.15 Scalable

Scalable is to read out arbitrary area of the image. Only single rectangle is selectable. Concave or convex shape is impossible. The number of selectable window is only one.

- Window size: $\{A+4*m (H)\} * \{B+4*n (V)\}$

A, B = minimum unit size

m, n = integer

The window size is equal or less than maximum image size.

- Start address: $\{4*i (H)\} * \{4*j (V)\}$

i, j = integer

The window size is equal or less than maximum image size.

Model Name	DDU1607MG/MCG/MCF
Width and OffsetX unit size	4
Height and OffsetY unit size	4
Minimum unit size (H) * (V)	64 x 64
Maximum unit size (H) * (V)	4000 x 4000

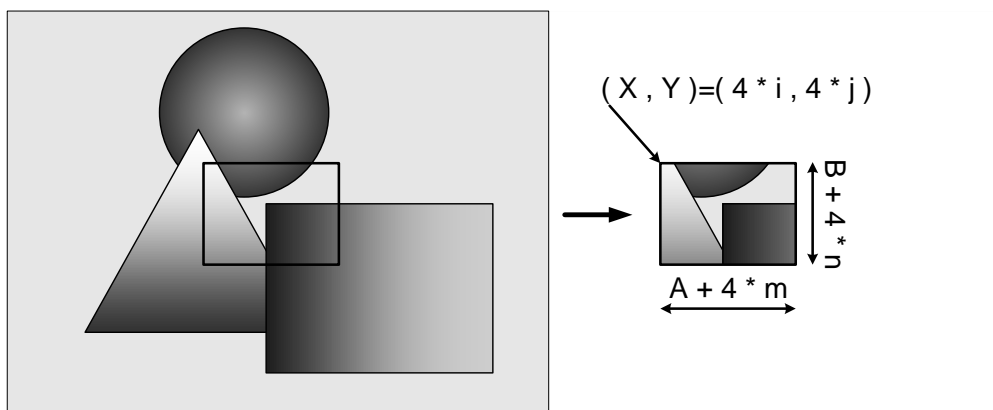

In the scalable mode, camera reads out only necessary area at the normal speed and reads out other area at high speed. The trigger interval can be shorter when the vertical height size is small.

5.16 Binning

In the binning mode, a pixel is added with the neighboring pixel(s).
Vertical and Horizontal can be set individually.

5.17 Decimation

Decimation feature reads out all effective areas at high speed by skipping pixels and lines.
Decimation feature can make frame rate faster.
Vertical and Horizontal can be set individually.

5.18 Reverse

Image can be flipped in horizontal and/or vertical direction.

5.19 Defect Pixel Correction

Defect Pixel Correction is available up to 256 pixels.

5.20 Image Buffer

Camera stores images temporarily in image buffer, and read them out in arbitrary timing.

5.21 User Free Memory

A free memory area is available to read and write arbitrary data for user. Individual numbers can be assigned when multiple BU cameras are connected.

5.22 Test Pattern

Following test patterns are available.

Black	: Full screen 0 LSB (@ 8-bit)
White	: All pixels 255 LSB (@ 8-bit)
Grey A	: Full screen 170 LSB (10101010 _B) (@ 8-bit)
Grey B	: Full screen 85 LSB (01010101 _B) (@ 8-bit)
Horizontal ramp waveform	
Vertical ramp waveform	
Grey scale(B/W models only)	
Color Bar (Color models only)	

6. Specifications

6.1 Electrical specification

Model Name	DDU1607MG
Optical part	Optical glass
Imager	CMOS image sensor
Number of effective pixels (H) x (V)	4000 x 4000
Scanning area (H) x (V) [mm]	12.8 x 12.8 (1.1 type)
Pixel size (H) x (V) [μm]	3.2 x 3.2
Scan method	Progressive
Electronic shutter method	Global shutter
Aspect ratio	Approx. 1:1
Sensitivity	2700lx, F8, 1/50s
Minimum illuminance	6lx (F1.4, Gain +8times, Video Level 50%)
Gain	MANUAL、AGC (factory setting : MANUAL)
Setting range	1 to +8times (factory setting : 1time)
AGC effective area	Set in arbitrary percentage. (factory setting : 100% (full screen))
Black Level	-25 to +25% (factory setting : 0% [0LSB@8bit])
Gamma	$\gamma=1.0$ to 0.45 (factory setting : $\gamma=1.0$)
LUT	Input 12 bit, Output 12 bit
Sharpness	0(OFF)~7 (factory setting : OFF)
Image Buffer	256M Byte
User Setting Memory	15 channels
User Free Memory	64 Byte
Test Pattern	Black, White, Grey A, Grey B Horizontal ramp waveform, Vertical ramp waveform, Grey scale (factory setting : OFF)
Power supply	DC +5V \pm 5% (from USB connector)
Power consumption(*1)	5.3W (maximum)

(*1) at the all pixel readout and Dual mode

Model Name	DDU1607MCG	DDU1607MCF
Optical part	Optical glass	IR cut filter
Imager	CMOS image sensor	
Number of effective pixels (H) x (V)	4000 x 4000	
Scanning area (H) x (V) [mm]	12.8 x 12.8 (1.1 type)	
Pixel size (H) x (V) [μ m]	3.2 x 3.2	
Color filter	RGB primary color mosaic-on-tip color filter	
Scan method	Progressive	
Electronic shutter method	Global shutter	
Aspect ratio	Approx. 1:1	
Sensitivity	2700lx, F5.6, 1/50s	3300lx, F5.6, 1/50s
Minimum illuminance	F1.4, Gain +8times, Video Level 50%	
	11lx	13lx
Gain	MANUAL、AGC (factory setting : MANUAL)	
Setting range	1 to +8times (factory setting : 1time)	
AGC effective area	Set in arbitrary percentage. (factory setting : 100% (full screen))	
Black Level	-25 to +25% (factory setting : 0% [0LSB@8bit])	
Gamma	$\gamma=1.0$ to 0.45 (factory setting : $\gamma=1.0$)	
White balance	MWB, OPWB (factory setting : MWB)	
Effective range	N/A	2,500~6,500K
MWB setting format	R/B gain independent setting	
OPWB effective area	Full pixel	
LUT	Input 12 bit, Output 12 bit	
Image Buffer	256M Byte	
User Setting Memory	15 channels	
User Free Memory	64 Byte	
Test Pattern	Black, White, Grey A, Grey B Horizontal ramp waveform, Vertical ramp waveform, Color bars (factory setting : OFF)	
Power supply	DC +5V \pm 5% (from USB connector)	
Power consumption(*1)	5.3W (maximum)	

(*1) at the all pixel readout and Dual mode

6.2 Electronic shutter specification

Exposure time	MANUAL、 AE (factory setting : MANUAL)
MANUAL	30 μ s to 1s
Exposure time Accuracy	$\pm 0.3\mu$ s
AE effective range	30 μ s to 1s
AE effective area	Same as AGC effective area setting
AE Exposure value	-2EV to +1.5EV

6.3 Random Trigger Shutter specification

Trigger Mode	External trigger, Software trigger (factory setting : External trigger)
External trigger	Input via I/O connector
Software trigger	USB3 Vision command control
Exposure time	Edge mode, Level mode (factory setting : Edge mode)
Edge mode	The exposure time depends on the MANUAL Exposure time setting
Level mode	The exposure time depends on External trigger width
Bulk mode	The exposure time depends on the MANUAL Exposure time setting
Number of Exposures in Bulk mode	255 times (maximum)
Sequential Shutter	16 entries (maximum)
Trigger Delay	0 to 2000000 μ s (factory setting : 0 μ s)
AntiGlitch	90ns to 2ms (factory setting : 90ns)
AntiChattering	2 μ s to 2ms (factory setting : 2 μ s)

6.4 GPIO Input signal specification

I/O Connector Pin No,	e-CON connector 4 Pin : Line0
Input / Output specification (LineMode)	Input only
Input circuit	
Input level	Low: 0 to 0.5V, High: 2.0 to 24.0V
Polarity	High active / Low active (factory setting : Low active)
Pulse width	50 μ s (minimum)
Input impedance	High impedance

External trigger input recommended circuit:

1) Isolated I/F

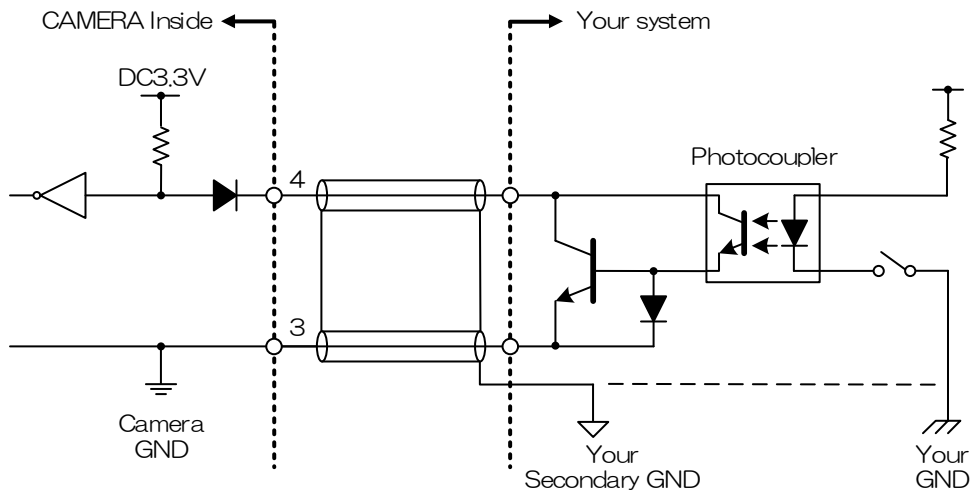

2) Non-isolated I/F

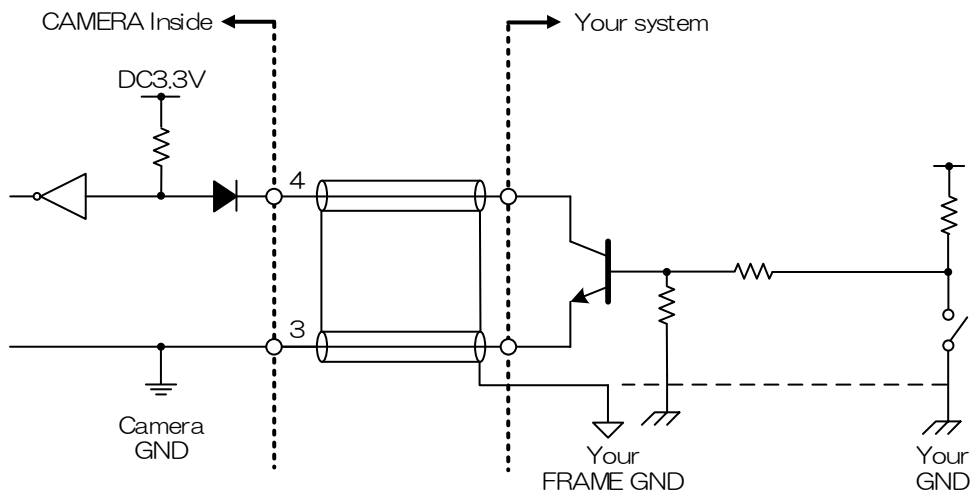

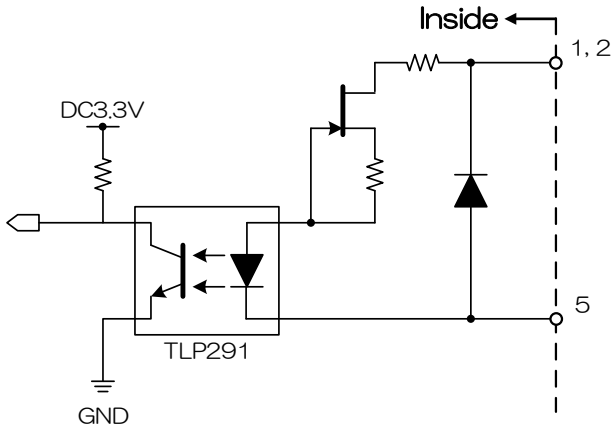
I/O Connector Pin No,	Round connector 1 Pin : Line4 Round connector 2 Pin : Line3
Input / Output specification (LineMode)	Input only
Input circuit	Photocoupler input  <p>*Depending on cable length, cable kinds and input current of trigger input line, Random Trigger Shutter operation may not satisfy timing specification or camera may not receive EXT_TRIG signal. Please confirm it before use.</p>
Input level	Low: 0 to 0.5V, High: 3.3 to 24.0V
Input current	5 to 15mA
Polarity	High active / Low active (factory setting : Low active)
Pulse width	200μs (minimum)

6.5 GPIO Input / Output signal specification

I/O Connector Pin No.	e-CON connector 1 Pin : Line2
Input / Output specification (LineMode)	Input / Output (switch by LineMode is possible) *Factory setting: Output
Input / Output circuit	<p>The diagram illustrates the internal circuit for Line2. It features a bidirectional buffer labeled 'LineModeAll'. The output of this buffer is connected to pin 1 through a pull-up resistor labeled 'DC5.0V'. Pin 1 is also connected to pin 3, which is grounded. The label 'Inside' with an arrow points to the internal components of the device.</p>
Input signal specification	
Input level	Low: 0 to 0.5V, High: 4.0 to 5.0V
Polarity	High active / Low active (factory setting : Low active)
Pulse width	50μs (minimum)
Input impedance	High impedance
Output signal specification	
Output signal (LineSource)	Off / UserOutput / Timer0Active / AcquisitionActive / FrameTriggerWait FrameActive / FrameTransferActive / ExposureActive (factory setting : Off)
Output level	5V CMOS
Maximum Current	+/-32mA
Polarity	High active / Low active (factory setting : Low active)
Timer0 Active	
Delay	0 to 2000000μs (factory setting : 0μs)
Duration	0 to 2000000μs (factory setting : 0μs)
TimerTriggerSource	Line0Active, ExposureStart, FrameTrigger

* Even if LineMode is set as Output, the input signal to Line2 is valid when LineSource is set as Off.

Note on Input Level:

- Line0,3,4 and Line2 have a different input level. Please use input level within the voltage described in this specification.

6.6 GPIO Output signal specification

I/O Connector Pin No.	e-CON connector 2 Pin : Line1
Input / Output specification (LineMode)	Output only
Output signal (LineSource)	Off / UserOutput / Timer0Active / AcquisitionActive / FrameTriggerWait FrameActive / FrameTransferActive / ExposureActive (factory setting : Off)
Output level	5V CMOS
Maximum Current	+/-32mA
Polarity	High active / Low active (factory setting : Low active)
Timer0 Active	
Delay	0 to 2000000 μ s (factory setting : 0 μ s)
Duration	0 to 2000000 μ s (factory setting : 0 μ s)
TimerTriggerSource	Line0Active, ExposureStart, FrameTrigger

I/O Connector Pin No.	Round connector 3 Pin : Line5 Round connector 4 Pin : Line6
Input / Output specification (LineMode)	Output only
Output signal (LineSource)	Off / UserOutput / Timer0Active / AcquisitionActive / FrameTriggerWait FrameActive / FrameTransferActive / ExposureActive (factory setting : Off)
Output Circuit	Open collector
Maximum Current	50mA (input current)
Polarity	High active / Low active (factory setting : Low active)
Timer0 Active	
Delay	0 to 2000000 μ s (factory setting : 0 μ s)
Duration	0 to 2000000 μ s (factory setting : 0 μ s)
TimerTriggerSource	Line0Active, ExposureStart, FrameTrigger

External trigger input/output recommended circuit:

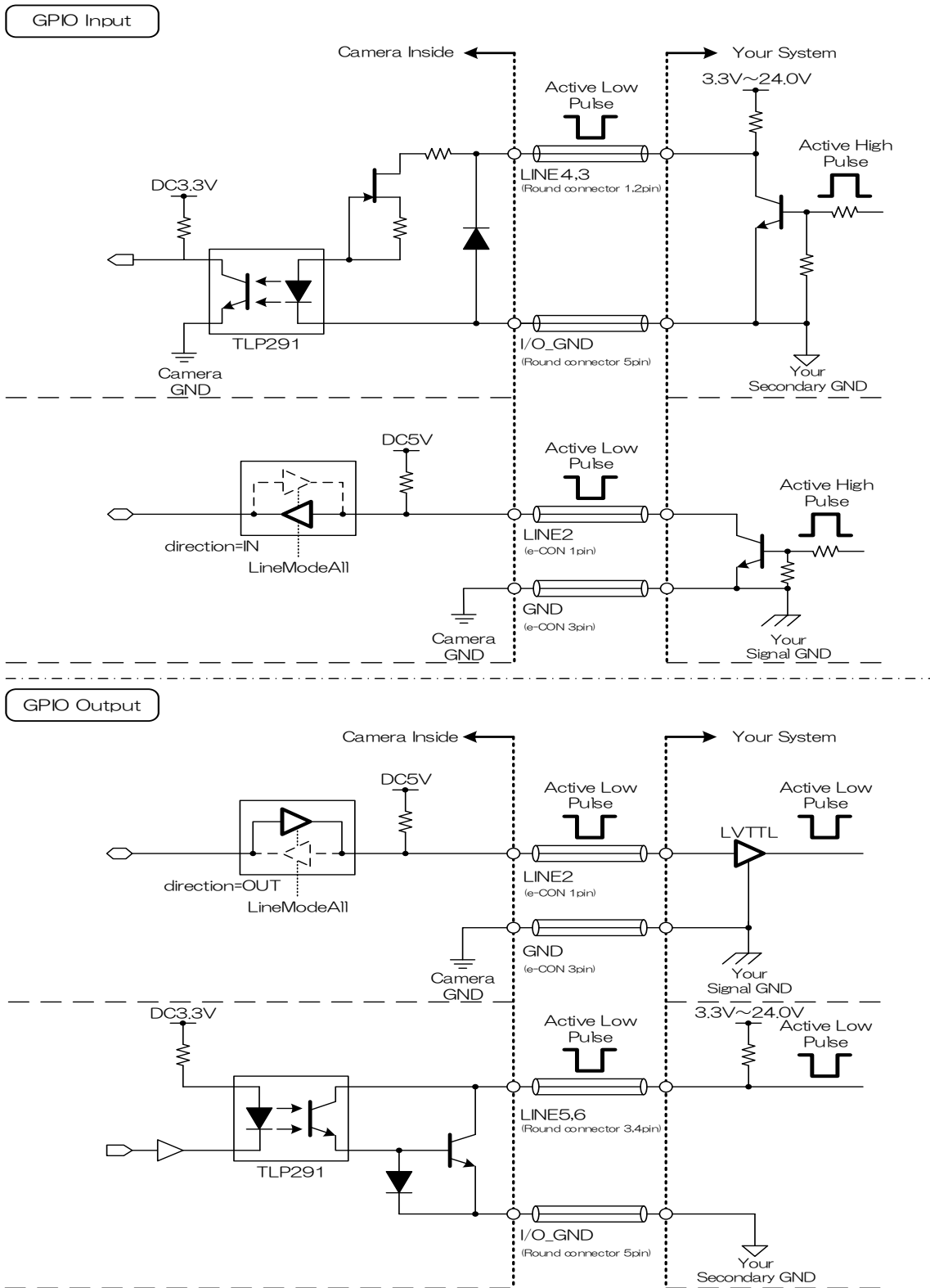

*Camera GND (e-CON connector Pin 3) and I/O_GND (Round connector Pin 5) are mutually isolated. It is also possible to connect them to common GND of your system.

6.7 Interface specification

Interface	USB 3.1 Gen1 (Only SuperSpeed is supported)
Transmission speed	5Gbps (Maximum) x 2
Protocol	USB3 Vision

6.8 LED states

Camera state	Lamp indication
No power	Off
Link detection in progress	Fast flash green (ON:20ms, OFF:60ms)
Connection Error	Flash alternate red / green
SuperSpeed connected, but no data being transferred	Flash green (ON: 200ms, OFF: 800ms)
SuperSpeed connected, waiting for trigger	Flash orange (ON: 200ms, OFF: 800ms)
Data being transferred	Fast flash green (ON:60ms, OFF:20ms)
Error during data transfer	Solid Red (Time period: 500ms)
Stand-by	Super slow flash orange (ON:200ms, OFF: 2800ms)

6.9 Image output format

Model Name		DDU1607MG	
Connection mode (Number of USB cables)		Dual mode (2)	Single mode (1)
Image output format		Mono8, Mono10, Mono12	
Number of Video out pixels (H) × (V)		4000 × 4000	
Maximum frame rate (at the all pixel readout)	Mono8	47 fps	23 fps
	Mono10, Mono12	23 fps	11 fps

Model Name		DDU1607MCG / MCF	
Connection mode (Number of USB cables)		Dual mode (2)	Single mode (1)
Image output format		Bayer8, Bayer10, Bayer12	
Number of Video out pixels (H) × (V)		4000 × 4000	
Maximum frame rate (at the all pixel readout)	Bayer8	47 fps	23 fps
	Bayer10, Bayer12	23 fps	11 fps

Notes on Dropping Frames:

- Depends on your PC or USB interface card configurations, images may not be captured normally (e.g. dropping frames may occur). In this case, change to frame rate setting lower.

6.10 Event notification

Event name	FrameTrigger, FrameTriggerError, FrameTriggerWait FrameTransferStart, FrameTransferEnd ExposureStart, ExposureEnd Timer0Start, Timer0End
Event notification delay	approx. 10us later from the event occurs
Time stamp unit	16.7ns (60.0MHz)

6.11 Machine external specification

Dimensions	40 mm(W) * 40 mm (H) * 35 mm (D) (Not including protrusion)
Mass	90g
Lens mount	C-mount
Flange back	17.526mm
Camera body grounding insulation status	Conductive between circuit GND and camera body

6.12 Optical axis accuracy

	Position accuracy of effective pixels		Rotation accuracy of effective pixels(θ)	Flange back (for 17.526mm)
	(X)	(Y)		
Optical axis accuracy	+/-25 μm	+/-25 μm	+/-0.07°	+/-50 μm

6.13 Operation Ambient conditions

Operation assurance	Temperature: -5°C to +45 °C, Camera housing temperature: less than 60 °C Humidity: 10% to 90% (no condensation)
Storage assurance	Temperature : -20°C to +60°C Humidity : +90% or less (no condensation)
EMC condition	EMI (Electro-Magnetic interference) : EN61000-6-4, FCC Part 15 Subpart B Class A EMS (Electro-Magnetic susceptibility) : EN61000-6-2

Notes on Heat Dissipation:

- The temperature of camera housing must be kept less than 60 °C.
Please provide sufficient heat dissipation depending on your installation.

Notes on Conformity of the EMC:

The adaptability of the safety standard of this camera is assured in the condition of combination with the following parts:

- USB Cable USB3-KR1-A-MBS-030 (OKI Electric Cable Co., Ltd.)
- e-CON Cable 3.0m, Shield cable (Fabricated parts)
- Round connector Cable 3.0m, Shield cable (Fabricated parts)

Parts:

- e-CON connector XN2A-1470 (OMRON Corporation)
- Round connector HR10A-7P-6S(73) (HIROSE ELECTRIC CO., LTD.)
- Shielded wire UL1533 (AWG28) (Hitachi Cable, Ltd.)

Connection:

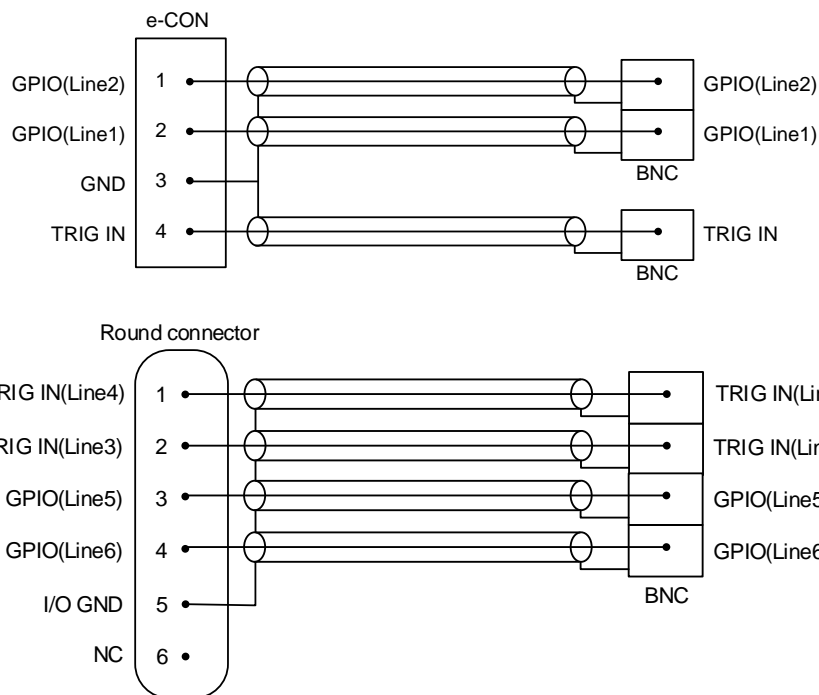

*Please confirm the EMC adaptability when it combines with parts other than them.

6.14 Connector pin assignment

USB 3.0 interface connector			
Connector model: WMUR-10F6L1PH5N (WIN WIN PRECISION INDUSTRIAL)			
Pin No.	I/O	Signal Name	Function
1	-	VBUS	Power
2	I/O	D-	USB2.0 differential pair
3	I/O	D+	
4	-	NC	Not Connected
5	-	GND	Ground for power return
6	O	SSTX-	SuperSpeed transmitter differential pair
7	O	SSTX+	
8	-	GND_DRAIN	Ground for SuperSpeed signal return
9	I	SSRX-	SuperSpeed receiver differential pair
10	I	SSRX+	

I/O Connector (e-CON Connector)

Connector (Camera side) 37204-62B3-004PL (3M Japan Limited) or equivalent
 Matching connector (Cable side) Connectors which conformed to e-CON
 e.g. 37104 series (3M Japan Limited),
 RITS 4P series (TE Connectivity Ltd.)

* Matching connector is not an accessory of this product.

Pin assignment

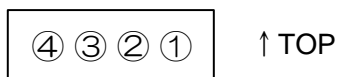

* Above figure is connector view from insert side.

Pin No.	I/O	Signal Name	Function
1	I/O	Line2	GPIO Input / Output
2	O	Line1	GPIO Output
3	-	GND	Ground
4	I	Line0	GPIO Input

I/O Connector (Round Connector)

Connector (Camera side) HR10A-7R-6PB(73) (HIROSE ELECTRIC CO., LTD.) or equivalent
 Plug (Cable side) HR10A-7P-6S(73) (HIROSE ELECTRIC CO., LTD.) or equivalent

* Matching connector is not an accessory of this product.

Pin assignment

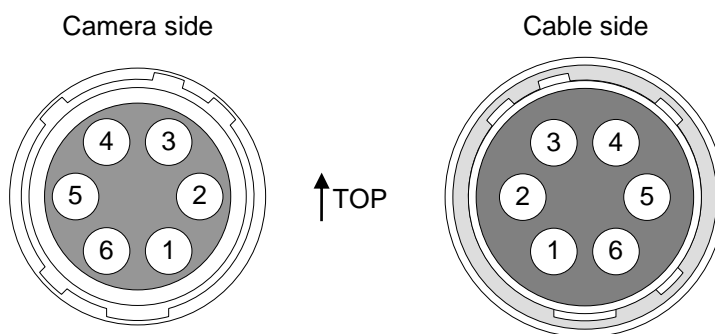

Pin No.	I/O	Signal Name	Function
1	I	Line4	GPIO Input
2	I	Line3	GPIO Input
3	O	Line5	GPIO Output
4	O	Line6	GPIO Output
5	-	I/O GND	GPIO Ground
6	-	NC	Not Connected

6.15 Typical spectral response

The lens characteristics and light source characteristics is not reflected in table.

<DDU1607MG>

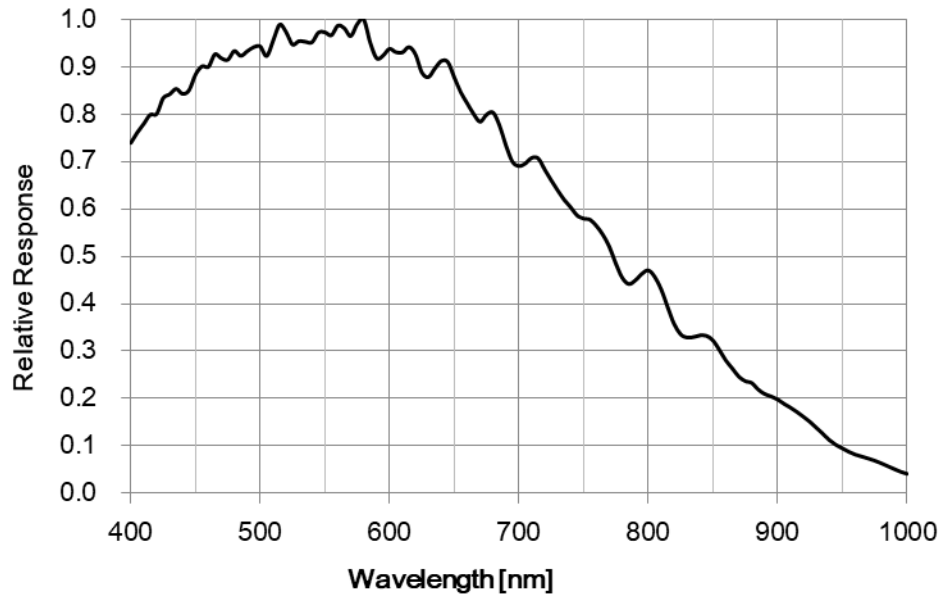

<DDU1607MCG>

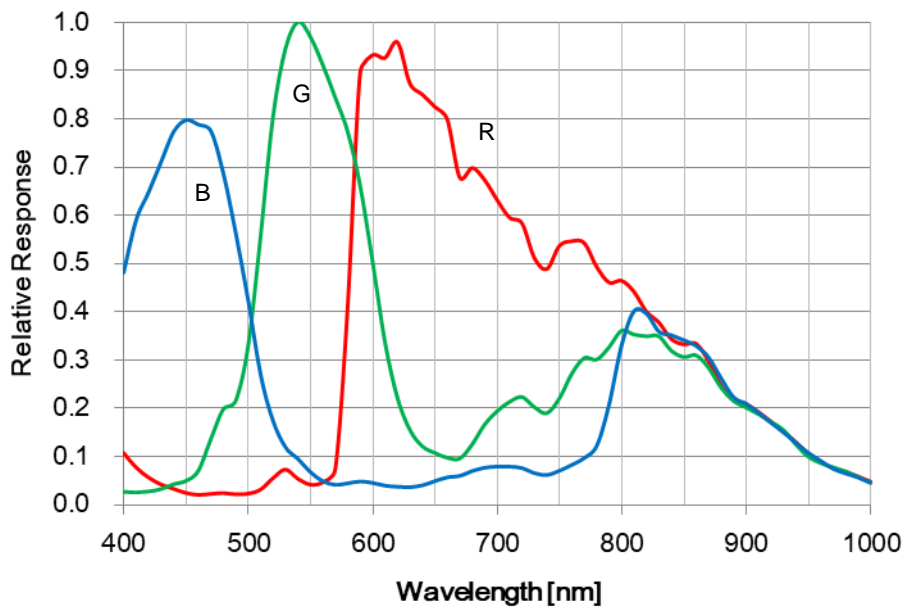

<DDU1607MCF>

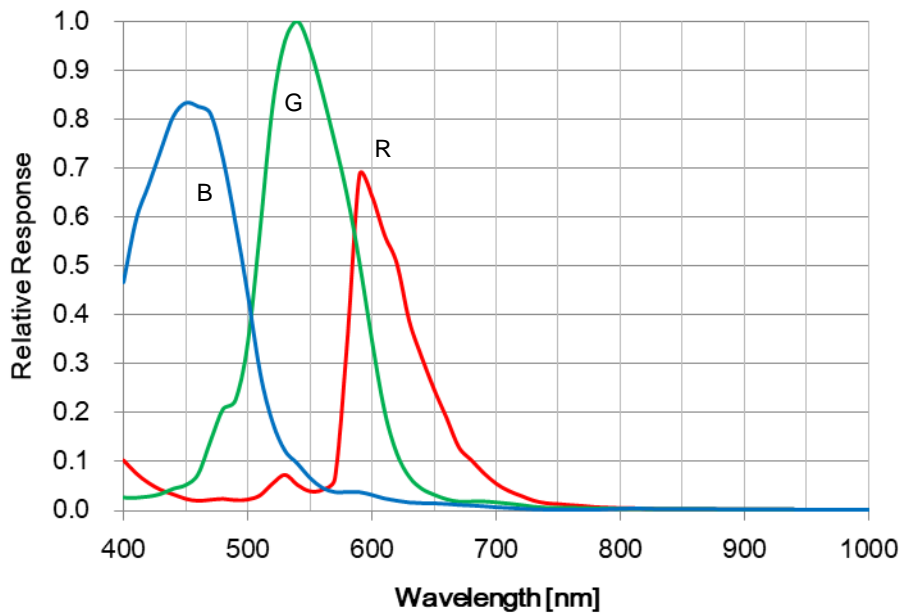

7. Timing chart

Image data outputs are transferred with USB bulk transfer. Timing numerical value below is described by absolute prerequisite that camera can use transmission band without restriction of other device. When there is other device on the same bus, the value described below is not guaranteed.

7.1 In Manual shutter mode (at all pixels readout)

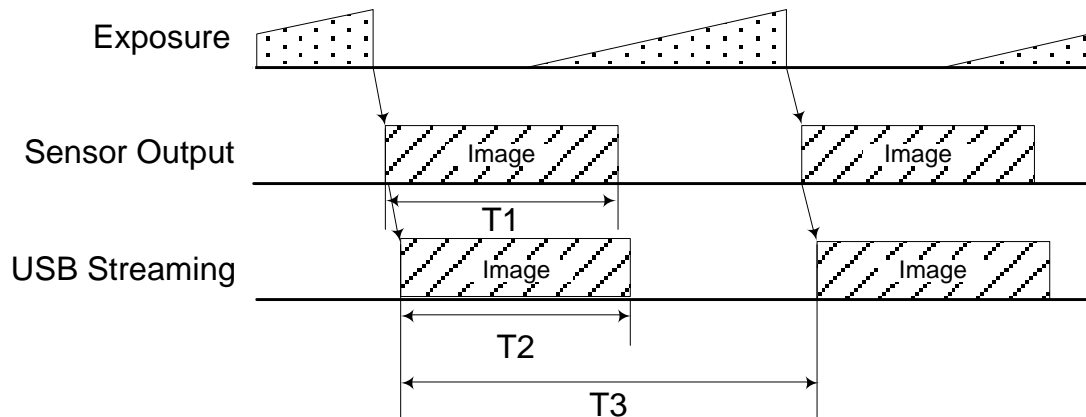

Model Name	Connection mode (Number of USB cables)	format	T1 [ms]	T2 [ms]	T3 [s]
DDU1607 MG/MCG/MCF	Dual mode (2)	Mono8 Bayer8	20.7	20.7	1/(Frame Rate setting)
		Mono10/12 Bayer10/12	20.7	39.2	
	Single mode (1)	Mono8 Bayer8	20.7	39.2	
		Mono10/12 Bayer10/12	20.7	78.4	

7.2 In Random Trigger Shutter mode

- Edge mode / Bulk mode (at all pixels readout)

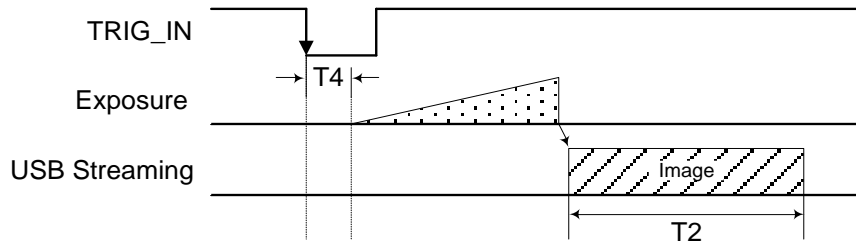

- Level mode (at all pixels readout)

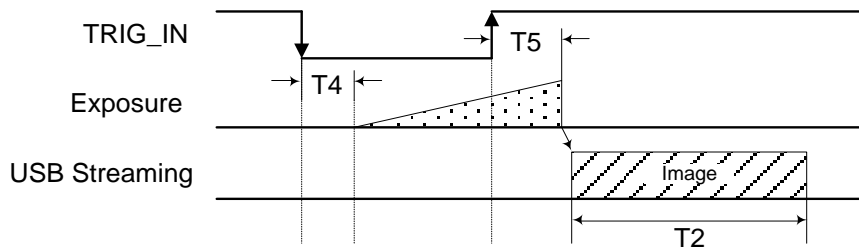

Model Name	TRIG IN	Polarity	format	T4 [μs]	T5 [μs]
DDU1607 MG/MCG/MCF	Line0 Line2	Active Low Active High	Mono8 Bayer8	27.2	18.4
			Mono10/12 Bayer10/12	27.2	18.4
	Line3 Line4	Active Low	Mono8 Bayer8	38.4	21.6
			Mono10/12 Bayer10/12	38.4	21.6
		Active High	Mono8 Bayer8	30.1	30.2
			Mono10/12 Bayer10/12	30.1	30.2

* The value of T2 is the same as the value of manual shutter mode.

* T4 and T5 are typical value.

* T4 and T5 is common in Dual mode and Single mode.

Notes of Random Trigger Shutter :

- In the period when FrameTriggerWait (refer to GPIO output signals) signal is inactive, user must not input external trigger signal to this camera.
- When the interval of the input trigger signal is extremely short, or when the trigger signal is noisy, there is a possibility of causing the malfunction. In this case, please input a proper trigger signal.

7.3 GPIO signal output

GPIO output Line 3.4 has a delay due to the difference of the output circuit for Line 1, 2.

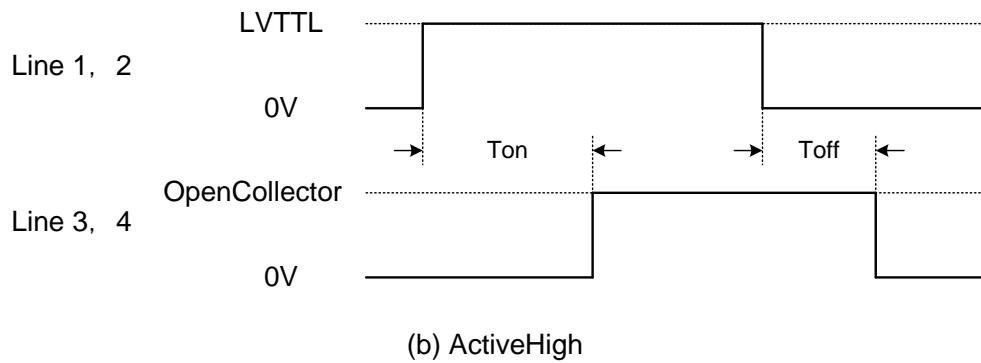
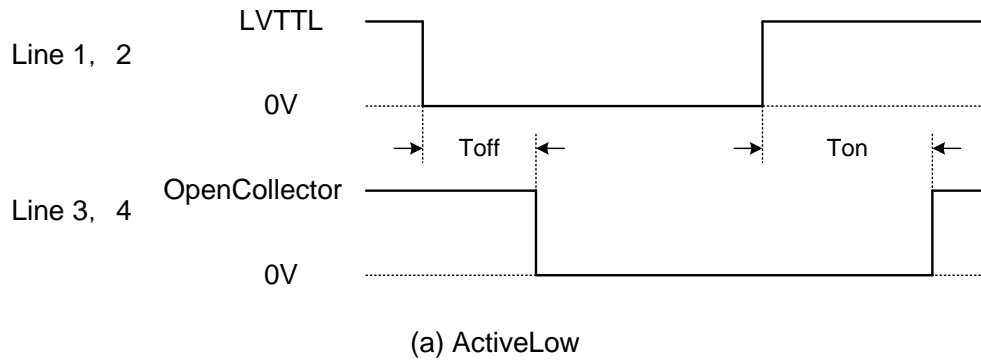

GPIO Signal Output Delay

Toff : Falling delay time of Line3, 4

Ton : Rising delay time of Line3, 4

Pull-up amplitude	Toff [μ s]	Ton [μ s]
+5V	2.	63

* Measured pulled up with 10k ohm register.

* Toff and Ton are typical value. These values are changed in operating environment.

8. Warranty rules

8.1 Warranty term

Warranty term is 36 months after your purchase. We may assume the date of the purchase from our shipping date when the date is unidentified.

8.2 Limited Warranty

Free warranty is not applicable for the troubles, damages or losses caused by the cases of the followings, even if it is during the warranty term.

1. Natural exhaust, wear or degradation of a component parts
2. Handling against the instructions and conditions described in the instruction manual
3. Remodeling, adjustment and the part exchange. (including the opening of the enclosure box and the alteration)
4. Using the accessories not included with the product or our non-designated optional articles
5. Damages caused during the transportation or deficiency of the handling such as drop or fall of the products after the products having been transferred to customers, leaving the products to corrosive environment such as sunlight, fire, sand, soil, heat, moisture, or an inappropriate storing method
6. A fire, an earthquake, a flood, a lightning, or other natural disasters, pollution and a short circuit, abnormal voltage, excessive physical pressure, theft, other accident
7. When connected to a product which is not recommended
8. When connected to the power supply which is not suitable
9. Forgery product, products which does not have proper serial number, products of which serial number is forged, damaged or deleted
10. All defects that happened after the expiration for a warranty term

9. Repair

9.1 Repair Methods

Basically, has to return it to our company when the user requests us to repair product.
In the case, exchange to a replacement or an equal function product.

9.2 Repair request methods

On the occasion of a repair request, please download the "Failure situation report sheet" from our website, fill in the necessary items and return it together with the defective product.

Repair Request Methods

http://www.toshiba-teli.co.jp/en/support/contact/failure_situation.htm

Please read the following instructions carefully.

1. Please return our product alone, taking out of your equipment in case that our product is installed to an equipment
2. We are unable to return the information such as your own serial numbers, control number, the identification seal, if it is attached to the returned products. Please keep record before you return the product.
3. As the data saved in the camera will not be kept after the repair, please take out data before return.
4. We are unable to accept the cancellation after the repair request by the customer's reason.
5. About the repair product shipping expenses, please bear the charges when you return the product to us. We bear the charges to you from us only for a warranty period.
6. We are unable to accept your request of a delivery date and time of the product return, or the delivery method.
7. We are unable to accept a trouble factor investigation, the request of the repair report.
8. We accept a repair of out of warranty product, if it is reparable.
9. The proprietary rights of the repair request products after the exchange repair belong to us.
10. The immunity from responsibility of the product is applied in the repair completion products.

* Please refer for the inquiry about the software to our homepage or sales personnel.

10. Outline Drawing

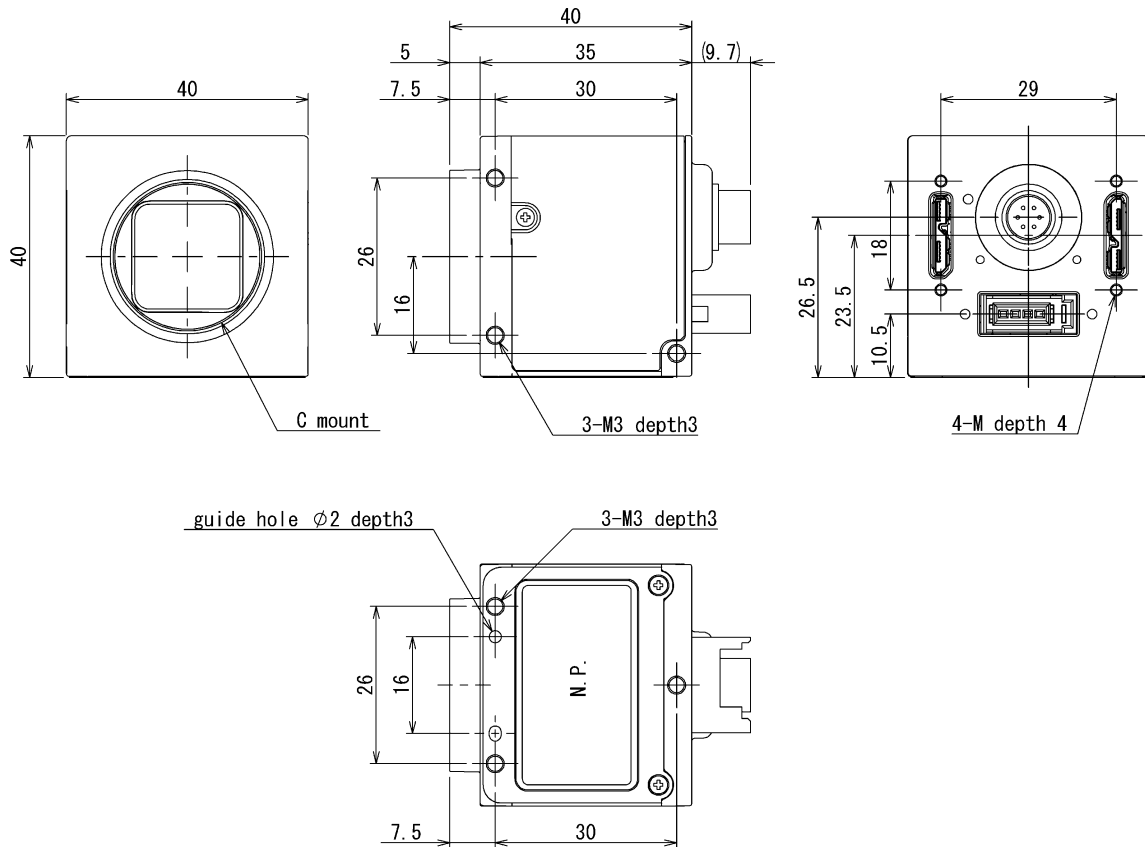

Specification

Material: Aluminum die-cast metal
 (Cover: Aerio aluminium)
 (Nameplate: Polyester film (Silver))
 Processing: Cationic coating (Black)
 (Cover: leather satin print (Black))