

MODEL PS-3 POSITION SWITCH

Bulk Pro
SYSTEMS L.L.C.



MODEL PS-3



The **Model PS-3 Position Switch** is utilized to monitor the position of heavy moving machinery such as a gravity take-up or a tripper car. Once the roller actuator arm is moved from its normal position the two (2) micro switches are tripped. The micro switches can be used to send an alarm to the controls system or operator telling it or them to either shut off or move the piece of heavy machinery.

The PS-3 Position Switch is commonly found on tripper floors to announce the position of the tripper car ensuring that the material is being unloaded in the correct spot. They are also utilized as a limit switch to protect gravity take-ups on conventional conveyors from bottoming out.

The PS-3 Position Switch is essentially a heavy duty limit switch and has a variety of uses in industrial environments. It assures safe operation and automation of the equipment in your plant.

Features:

- Robust die cast aluminum housing with epoxy based powder coat finish and all stainless steel external hardware.
- Integral cover, permits easy access to the wiring terminals and adjustments.
- Easily removed cover without the requirement of removing the actuator arm.
- Anti-corrosion nylon roller arm requires only 4.5 lbs (2kg) of activating force
- Normal roller arm angle adjustment within ± 22.5 .
- Actuation roller arm can be mounted in any direction within 360 degrees in 22.5° increments.
- Actuation roller arm automatically resets once the force is removed.

SPECIFICATIONS

Model PS-3, Position Switches Technical Specifications

- Rugged die cast aluminum enclosure
- NEMA-4X, IP-66/67
- Yellow epoxy based powder coat paint finish with red roller arm
- Micro switch rating: 15A @ 115-230 VAC, 30 VDC non-inductive, CSA 10A @ 115-250 VAC
- Outputs: (2) SPDT
- Actuation angle: 20° from normal
- Conduit holes: (3) 3/4" - 14 NPT
- Temperature rating: -40° to 176° F (-40° to 80°C), CSA -22°F to 140°F (-30° to 60°C)
- Bi-Directional action for ease of installation, wiring and component savings
- Cover provides easy access to wiring & internal mechanism

Options

- Indicating Lights
- Manual Lock Out

Outline Dimensions All Dimensions in Millimeters (Inches)

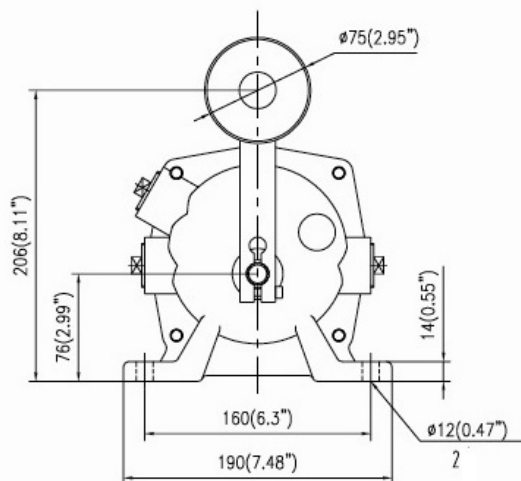
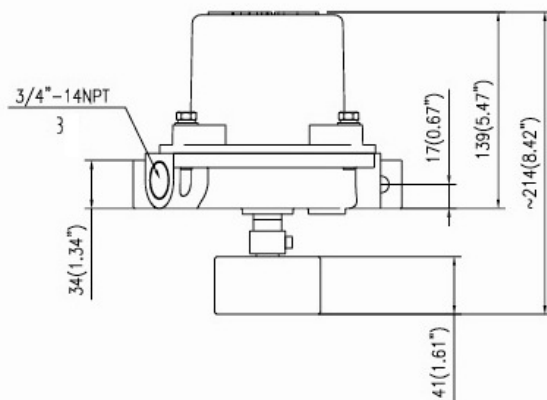

Applications:

- Heavy Duty Limit Switch
- Gravity take-up positioning, conventional belt conveyors
- Tripper car positioning
- Traveling cranes
- Travelling skips
- Ship loading and unloading systems
- Stockpile/reclaim systems



Hazardous Approval Rating (model PS-3X)

- Class 2258-02-Process Control Equipment-For Hazardous Locations.
- Class 2258-82-Process Control Equipment-For Hazardous locations-Certified to U.S. Standards.
- Approved for Class II, Div. 1 & 2, Groups E, F & G Hazardous Locations
- NEMA-9