

# PRODUCT CATALOG

## F-SERIES

Indicators  
Totalizers  
Transmitters  
Flow Computers  
Batch Controllers  
Monitors  
Displays

Flow  
Level  
Pressure  
Temperature

FOR



# INTRODUCTION TO THE F-SERIES

The F-Series range offers you an extensive selection of indicators, controllers and monitoring systems for liquid and gas flow applications as well as for level, pressure and temperature measurement.



## Industrial applications

The F-Series range has been developed for typical industrial environments. It is sturdy and weather-proof through its aluminum or GRP IP67 / NEMA 4X field enclosure. The enclosure can be mounted directly onto sensors, walls or pipes, but is also suitable for panel mount applications, with one major advantage: it requires minimal depth clearance. The operational temperature specification of the product range is from  $-40^{\circ}\text{C}$  to  $+80^{\circ}\text{C}$  ( $-40^{\circ}\text{F}$  to  $+178^{\circ}\text{F}$ ).

## Operational

Fluidwell is acutely aware of the excessive amount of equipment which today's technicians need to control. For this reason, a clear user-friendly menu structure was developed for programming all Fluidwell products a number of years ago: all models are programmed in the same logical manner. The configuration of the unit is completely menu-driven with understandable texts avoiding confusing abbreviations. There are no sensitive DIP-switches or trimmers, you simply select "Flowmeter" as main function, after which you can select "Coil-input" or "Span". The Operator's main information is displayed in clear 17mm (0.7") or 26mm (1") and 8mm (0.3") alphanumeric characters. An adjustable bi-color backlight is available that will switch from green to red in case an alarm is triggered.



## Input features

- For flow measurement, the instrument accepts signals from most flowmeters, ranging from PD-meters with reed-switches or hall-effect sensors to turbine sine wave (coil) pick-ups and other NPN/PNP pulse outputs. NAMUR standard sensors and (0)4 - 20mA or 0 - 10V DC analog devices are also catered for.
- For level and pressure measurement, inputs are available for (0)4 - 20mA or 0 - 10V DC signals.
- For temperature measurement, the instrument accepts (0)4 - 20mA or 0 - 10V DC signals, also 2, 3 or 4 wire PT100 elements and thermocouple.

Linearization of the input signal, square root calculation and data filter functions are all available.



## Output features

Related to the functionality of the selected product, the following output features are available:

- Analog output proportional to the flow rate, level, differential, ratio, temperature, pressure position or control value. This turns the unit into a powerful transmitter with a local display. The output can also be used to control actuators, valves or pumps.
- Transistor or relay outputs for high and low alarms, pulse output as well as the control of valves / relays in batch control applications.
- The RS232, RS485 or TTL interface makes it possible to communicate remotely, even with the battery-powered unit. All software parameters can be monitored / modified in addition to the usual transfer of data using the Modbus protocol.

## Power Management

During the development of the F-Series products, ultra-low power consumption was a key-requirement. Thanks to recent advancements in CMOS technology, Fluidwell has extended the battery life significantly and introduced several smart power-management functions.

Result: a battery lifetime of seven years can be achieved. Additionally, several alternative means of powering the F-Series are available: loop-powered, 24V AC/DC and 115 - 230V AC.

Since all settings are stored in EEPROM memory, you won't lose information when replacing the battery or in the event of sudden power loss. A backup of the running totals is made every minute.

## Hazardous area installation

Both Fo- and F1-Series products can be supplied certified Intrinsically Safe to ATEX  II 1 GD EEx ia IIB/IIC T4. For the basic Fo-Series products, certification to IECEx, FM, CSA and non-incendive is expected in the fourth quarter of 2006 with following specifications:

- Intrinsically Safe Class I, II, or III, Division 1, Groups A through G, Ex ia Class I, Zone 0 and 1, Group IIC.
- Non-Incendive Class I, II, or III, Division 2, Groups A through G, Ex nA Class I, Zone 2, Group II.

An explosion-proof enclosure is also available which has been certified in accordance to ATEX  II 2 GD EEx d IIB T5.

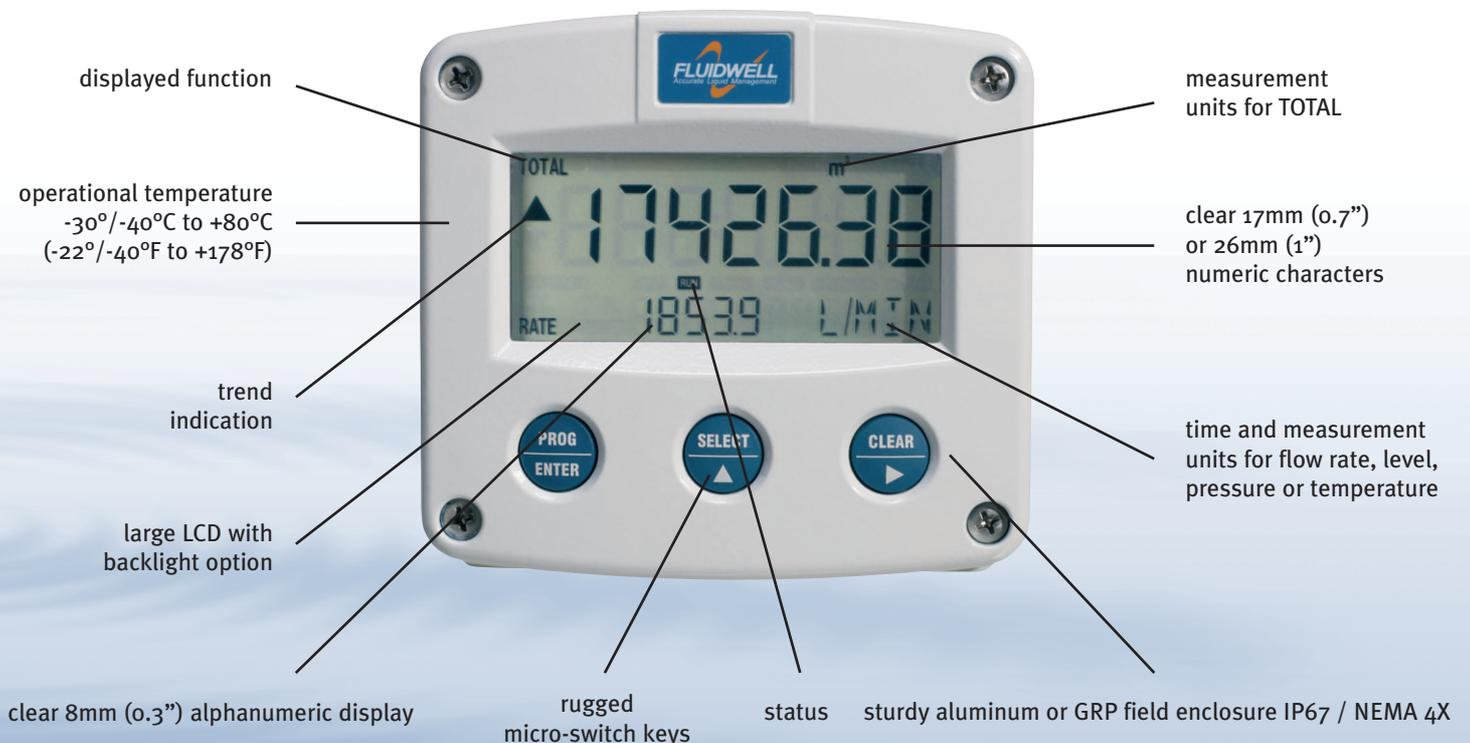

# LEVEL INDICATORS, MONITORS AND TRANSMITTERS



## Introduction

This product group offers a range of solutions from a basic level indicator up to a powerful level monitor with tank-shape linearization, high / low level monitoring, signal re-transmitting, four alarm outputs as well as full Modbus communication. All being available for both safe area and hazardous area applications. Moreover, wireless data re-transmitting, remote level monitoring and vendor managed inventory - VMI - is offered with our M-series and ProcessMonitor.com products and services.

The functionality of these products is based on two main hardware platforms:

- F0 platform: these products offer one signal input and can have one alarm or control output. This is our basic product range.
- F1 platform: these products have one or more signal inputs, multiple outputs and communication option. This is our advanced product range.

Both platforms share the same technology, enclosures, display and options but are dedicated to their typical functionality.



## Common Level Indicator features

- Clear operator information is a key feature of these products. Essential information is displayed as a clear text (e.g. “low level”) and not as mysterious abbreviations.
- The dedicated display shows two lines of information at the same time, so the actual level is displayed simultaneously with the height, percentage or alarm message.
- The level is displayed with six 17mm (0.67”) high digits or even with 26mm (1”) high digits (F070) with its engineering unit. Following units can be selected through software: ml, L, m<sup>3</sup>, GAL, USGAL, kg, lb, bbl or no unit.
- The height or percentage filled is displayed with 8mm (0.31”) digits. Following engineering units can be selected: mm, cm, m, mtr, inch, ft, mmwc, mmwc, cmwk, cmwc, mwk, mwc, inwc, ftwc, mbar, bar, psi or no unit.

Further product specific features are found on the following pages.



## Configuration menu

All configuration settings are accessed via a simple operator menu which can be password protected. Each setting is clearly indicated with an alphanumeric description, therefore avoiding confusing abbreviations and baffling codes. There are no sensitive DIP-switches or trimmers, you simply select “Sensor” as main function, after which you can select “span” or “offset” etc. Once familiar with one F-Series product, you will be able to program all models in the series without a manual. All settings are safely stored in EEPROM memory. The clear and easy structured configuration menu is one of the most appreciated features of the F-Series.

## Signal input type

For the level indicators, two basic signal input types are available:

- Analog signal: (0)4 - 20mA or 4 - 20mA input loop powered version. The input signal can be tuned within this range (e.g. from 4.0mA to 18.0mA). To avoid signal processing at minimum signal, a low cut-off filter is available.

- Analog signal: 0 - 10V DC. The input signal can be tuned within this range (e.g. from 2.0 to 5.0V DC). A low cut-off filter is available here too, to avoid counting at minimum signal.

Further, a digital filter can be set to a desired value to stabilize the level measurement reading. The offset function allows the sensor to be mounted above a not measured quantity (e.g. from 230 L). With the span, the indicator can be set to be operational within any desired range (e.g. from 230 L to 10,000 L).

## Data protection

All settings are stored in EEPROM memory ensuring that information is not lost in the event of power failure or battery exchange. The configuration menu and alarm values can be password protected to prevent unauthorized access.

For an explanation of all the F-Series options such as analog and alarm outputs, communication, power supply and enclosures, please read the section “Ordering codes” in the back of this catalog.

## Product listing

- F070 Level Indicator.
- F073 Level Monitor with two high / low alarm values and one alarm output.
- F074 Level Controller with one control output.
- F077 Level Monitor with two high / low alarm values, eight point tank-shape linearization and one alarm output.
- F170 Level Monitor / Totalizer with four high / low alarm values, max. four alarm outputs, analog output and communication option.
- F173 Level Monitor / Totalizer with four high / low alarm values, fifteen linearization points, max. four alarm outputs, analog output and communication option.

# F070 Level Indicator with very large digits

The F070 is a straight forward level indicator with large 26mm (1") high digits. It can be set to display the level as a quantity, height or as a percentage. The measuring unit to be displayed is simply selected through an alphanumeric configuration menu. No adhesive labels have to be put on the outside of the enclosure: a weather proof and user-friendly solution!

The configuration of the Span, off-set and number of decimals is done through software functions, without any sensitive DIP-switches or trimmers. A wide range of options further enhance this model capabilities, including Intrinsic Safety for hazardous area applications.

## Features

- Displays level and height or percentage filled.
- Very large 26mm (1") high digits for level.
- Piegraph indication: ten segments.
- Selectable on-screen engineering units for level: ml, L, m<sup>3</sup>, GAL, USGAL, kg, lb, bbl or no unit.
- Selectable on-screen units for height: mm, cm, m, mtr, inch, ft, mmwk, mmwc, cmwk, cmwc, mwk, mwc, inwc, ftwc, mbar, bar, psi or no unit.
- Number of digits for level: 5<sup>1</sup>/<sub>2</sub>.
- Green/amber LED backlight with adjustable intensity.
- Auto backup of settings in EEPROM memory.
- Operational temperature -40°C to +80°C (-40°F to 178°F).
- Easy configuration with clear alphanumeric display.
- Very compact design for panel mount, wall mount or field mount applications.

## Applications

- Applications where a basic level measurement display is required without level monitoring, linearization or signal re-transmitting. More advanced models: F073, F077, F170 and F173.

## Display example



## Level input

- Analog: (0)4 - 20mA, 0 - 10V DC.

## Analog output

- No.

## Alarm output

- No.

## Communication

- No.

## Power supply

- Loop or battery powered, 8 - 24V AC/DC or 115 - 230V AC. Sensor supply 8.2, 12 or 24V DC.

## Hazardous area

- ATEX, IECEx, CSA and FM approvals available for Intrinsically Safe and non-incendive applications.
- ATEX approval available for explosion proof enclosure.

## Application overview

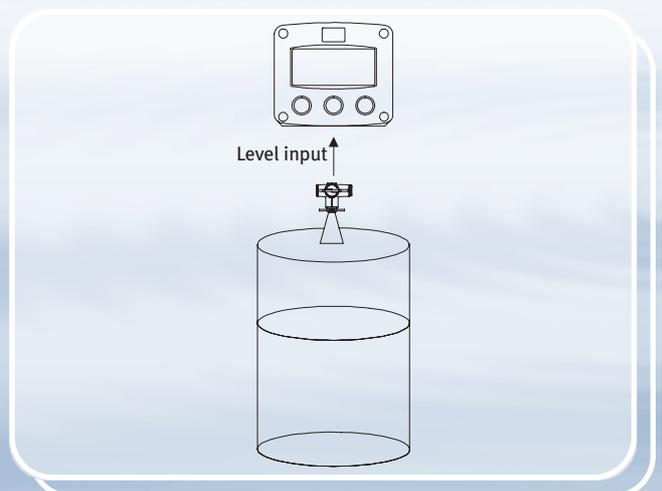

# F073 Level Monitor with one high / low alarm output

The F073 is a versatile level indicator with continuous level monitoring feature. It offers the ability to set one low level and one high level alarm value. If desired, an alarm ignore function can be set up to allow for an incorrect level for a certain period of time. The configuration of the Span, off-set and number of decimals is done through software functions, without any sensitive DIP-switches or trimmers. The display shows the actual level, height or percentage, alarm values, alarm messages and status. On-screen engineering units are easily configured from a comprehensive selection. A wide range of options further enhance this model capabilities, including Intrinsic Safety for hazardous area applications.

## Features

- Displays level and height or percentage filled simultaneously.
- Level monitoring: two alarm values can be set: low and high level alarm.
- Alarm values can be changed by the operator or they can be password protected.
- One alarm output for high, low or both level alarms.
- Level: six large 17mm (0.67") digits.
- Selectable on-screen engineering units: ml, L, m<sup>3</sup>, GAL, USGAL, kg, lb, bbl or no unit.
- Selectable on-screen units for height: mm, cm, m, mtr, inch, ft, mmwk, mmwc, cmwk, cmwc, mwk, mwc, inwc, ftwc, mbar, bar, psi or no unit.
- Red flashing LED backlight in case of a level alarm; intensity adjustable.
- Displays clear alarm messages.
- Auto backup of settings in EEPROM memory.

## Applications

- Level measurement where continuous level monitoring is important without signal re-transmitting. Alternative advanced models: F077 and F173.

## Display example



## Level input

- Analog: (0)4 - 20mA, 0 - 10V DC.

## Analog output

- No.

## Alarm output

- One configurable alarm output for high, low or both level alarms.

## Communication

- No.

## Power supply

- Loop or battery powered, 8 - 24V AC/DC or 115 - 230V AC. Sensor supply 8.2, 12 or 24V DC.

## Hazardous area

- ATEX, IECEx, CSA and FM approvals available for Intrinsically Safe and non-incendive applications.
- ATEX approval available for explosion proof enclosure.

## Application overview

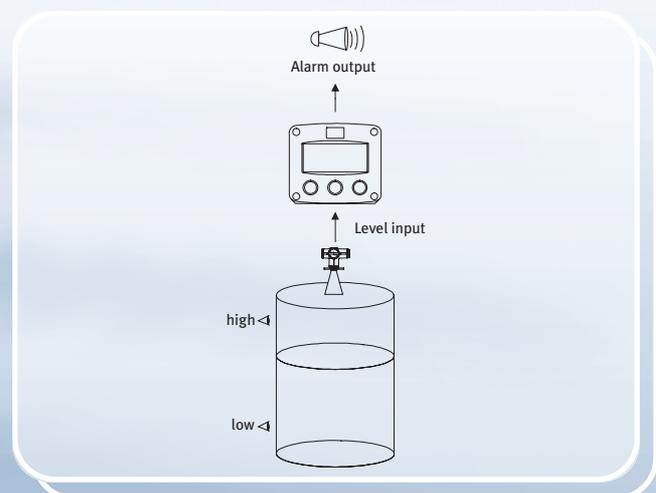

# F074 Level / Pump Controller with one control output

The F074 is a basic level / pump controller that works with a preset value and two switch points to control a pump or valve. The low and high level switch points are entered as a percentage of the preset value to switch the device on / off. For pump control applications, the function can be inverted to empty a well. A stable level within a band around the preset value is the result. The display shows the actual level, preset value, high / low switch points and status. On-screen engineering units are easily configured from a comprehensive selection. The configuration of the Span, off-set and number of decimals is done through software functions, without any sensitive DIP-switches or trimmers.

## Features

- Level control: high / low switch points and a preset value can be set.
- Displays actual level and preset value.
- Switch points and preset value can be set by the operator or being password protected.
- One control output for on / off pump or valve control.
- Functions for filling-up a container or emptying a well or tank.
- Level: six large 17mm (0.67") digits.
- Selectable on-screen engineering units: ml, L, m<sup>3</sup>, GAL, USGAL, kg, lb, bbl or no unit.
- Green/amber LED backlight with adjustable intensity.
- Auto backup of settings in EEPROM memory.
- Operational temperature -40°C up to +80°C (-40°F up to 178°F).
- Very compact design for panel mount, wall mount or field mount applications.

## Applications

- Basic on / off level control applications without PI(D) control. Also very suitable for applications where the required level changes frequently.

## Display example



## Level input

- Analog: (0)4 - 20mA, 0 - 10V DC.

## Analog output

- No.

## Control output

- One on / off control output (e.g. for pump or valve control) with the high / low level values.

## Communication

- No.

## Power supply

- Loop or battery powered, 8 - 24V AC/DC or 115 - 230V AC. Sensor supply 8.2, 12 or 24V DC.

## Hazardous area

- ATEX, IECEx, CSA and FM approvals available for Intrinsically Safe and non-incendive applications.
- ATEX approval available for explosion proof enclosure.

## Application overview

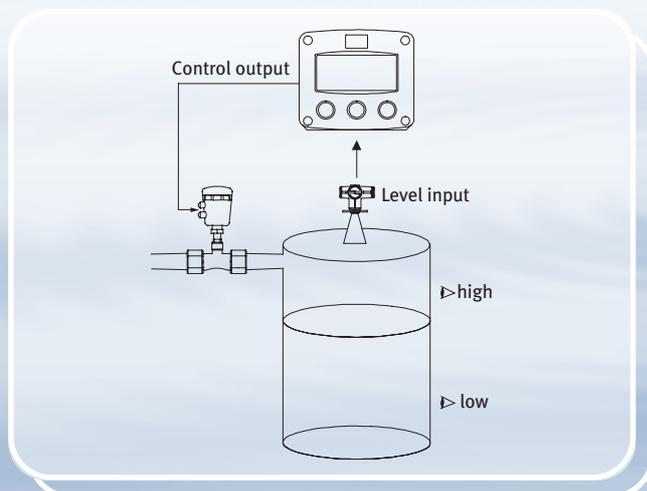

# F077 Level Monitor with linearization and one high / low alarm output

The F077 is a versatile level indicator with linearization and continuous level monitoring feature. In addition to the average Span, eight linearization points can be entered to compensate for the tank-shape. The unit will interpolate between these points to increase the accuracy. With the level monitoring feature, one low level and one high level alarm value can be set. The configuration of the Span, off-set and number of decimals is done through software functions, without any sensitive DIP-switches or trimmers. The display shows the actual level, height or percentage, alarm values, alarm messages and status. On-screen engineering units are easily configured from a comprehensive selection.

## Features

- Eight point linearization of the tank-shape - with interpolation.
- Level monitoring: two alarm values can be set: low and high level alarm.
- Displays level and height or percentage filled simultaneously.
- Alarm values can be changed by the operator or they can be password protected.
- Level: six large 17mm (0.67") digits.
- Selectable on-screen engineering units: ml, L, m<sup>3</sup>, GAL, USGAL, kg, lb, bbl or no unit.
- Selectable on-screen units for height: mm, cm, m, mtr, inch, ft, mmwk, mmwc, cmwk, cmwc, mwk, mwc, inwc, ftwc, mbar, bar, psi or no unit.
- Red flashing LED backlight in case of a level alarm; intensity adjustable.

## Applications

- Level measurement where continuous level monitoring and linearization of the tank-shape is important without signal re-transmitting. Alternative basic models F070 and F073 or more advanced F170 and F173.

## Display example



## Level input

- Analog: (0)4 - 20mA, 0 - 10V DC.

## Analog output

- No.

## Alarm output

- One configurable alarm output for high, low or both level alarms.

## Communication

- No.

## Power supply

- Loop or battery powered, 8 - 24V AC/DC or 115 - 230V AC. Sensor supply 8.2, 12 or 24V DC.

## Hazardous area

- ATEX, IECEx, CSA and FM approvals available for Intrinsically Safe and non-incendive applications.
- ATEX approval available for explosion proof enclosure.

## Application overview

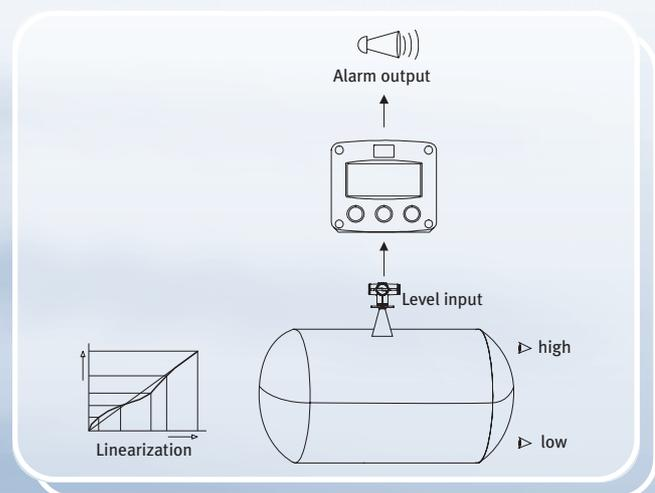

# F170 Level Monitor with analog and high / low alarm outputs

The F170 is a versatile level indicator with continuous level monitoring feature. It offers the ability to set two low level and two high level alarm values. If desired, an alarm ignore function can be set up to allow for an incorrect level for a certain period of time. Up to five outputs are available to transmit the actual level and alarm condition. The display shows the actual level, height or percentage, alarm values, alarm messages and status. On-screen engineering units are easily configured from a comprehensive selection. A wide range of options further enhance this model capabilities, including Intrinsic Safety and full Modbus communication.

## Features

- Level monitoring: four alarm values can be set: low-low, low, high and high-high level alarm.
- Alarm values can be changed by the operator or they can be password protected.
- Analog output to transmit the actual level.
- Up to four configurable alarm outputs.
- Level: six large 17mm (0.67") digits.
- Displays level, height or percentage and measuring unit simultaneously.
- Alarm ignore function allows an incorrect level for a certain period of time.
- Displays clear alarm messages.
- LED backlight available.

## Applications

- Level measurement where continuous level monitoring and re-transmitting is important or serial communication is required. Alternative basic model: F070, F073, F077 or more advanced model F173.

## Level input

- Analog: (0)4 - 20mA, 0 - 10V DC.

## Display example



## Analog output

- One (0)4 - 20mA / 0 - 10V DC output to transmit the level. The signal can be scaled to any range (e.g. from 2.5m<sup>3</sup> to 1400.0m<sup>3</sup>).

## Alarm outputs

- Up to four configurable alarm outputs for low-low, low, high, high-high or any combination.

## Communication

- RS232 / RS485 / TTL. Modbus ASCII / RTU protocol. All process data and settings are accessible.

## Power supply

- Loop or battery powered, 8 - 24V AC/DC or 115 - 230V AC. Sensor supply 8.2, 12 or 24V DC.

## Hazardous area

- ATEX approval available for Intrinsically Safe and explosion proof applications.

## Application overview

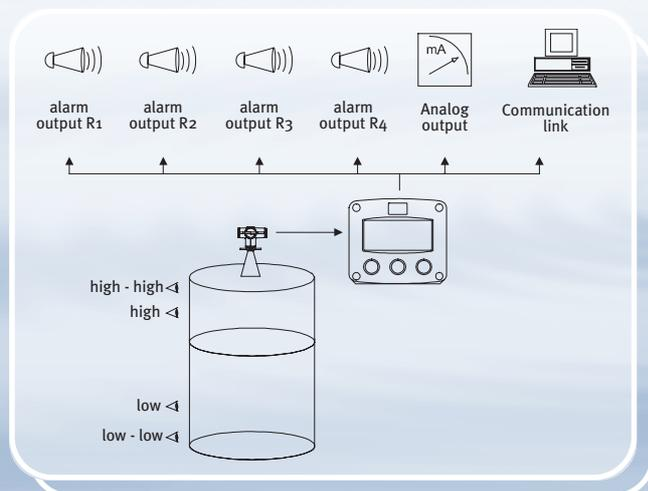

# F173 Level Monitor with linearization, analog and high / low alarm outputs

The F173 is a versatile level monitor with linearization and continuous level monitoring feature. In addition to the average Span, fifteen linearization points can be entered to compensate for the tank-shape. The unit will interpolate between these points to increase the accuracy. With the level monitoring feature, one low level and one high level alarm value can be set. It offers the ability to set two low level and two high level alarm values. If desired, an alarm ignore function can be set up to allow for an incorrect level for a certain period of time. Up to five outputs are available to transmit the alarm condition and actual level. The display shows the actual level, height or percentage, alarm values, alarm messages and status.

## Features

- Fifteen point linearization of the tank-shape - with interpolation.
- Level monitoring: four alarm values can be set: low-low, low, high and high-high level alarm.
- Alarm values can be changed by the operator or they can be password protected.
- Analog output to transmit the actual level.
- Up to four configurable alarm outputs.
- Level: six large 17mm (0.67") digits.
- Displays level, height or percentage and measuring unit simultaneously.
- Alarm ignore function allows an incorrect level for a certain period of time.
- Displays clear alarm messages.

## Application

- Level measurement where linearization of the tank-shape and continuous level monitoring and re-transmitting is important or serial communication is required. Alternative basic model: F070, F073, F077 and F170.

## Level input

- Analog: (0)4 - 20mA, 0 - 10V DC.

## Display example



## Analog output

- One (0)4 - 20mA / 0 - 10V DC output to transmit the level. The signal can be scaled to any range (e.g. from 2.5m<sup>3</sup> to 1400.0m<sup>3</sup>).

## Alarm outputs

- Up to four configurable alarm outputs for low-low, low, high, high-high or any combination.

## Communication

- RS232 / RS485 / TTL. Modbus RTU protocol. All process data and settings are accessible.

## Power supply

- Loop or battery powered, 8 - 24V AC/DC or 115 - 230V AC. Sensor supply 8.2, 12 or 24V DC.

## Hazardous area

- ATEX approval available for Intrinsically Safe and explosion proof applications.

## Application overview

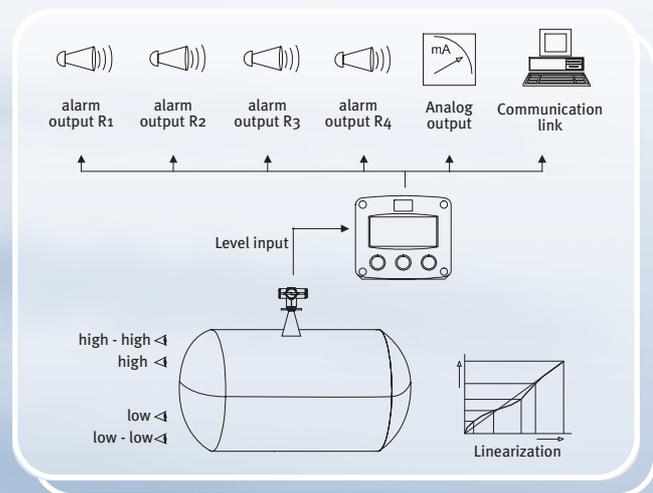

# ORDERING CODES

This section describes the options and ordering codes of all F-Series products.



The  symbol indicates if the function is available Intrinsically Safe. The table on the following pages shows which options are available for each product. As it is our policy to improve our products continuously, it is advised to check the datasheets on our website [www.fluidwell.com](http://www.fluidwell.com) for up-to-date information about the latest options available.

## Sensor input signal

This is the primary signal input type of the device. The configuration menu of each product allows you to select and adjust the signal parameters, without any sensitive mechanical DIP-switches, jumpers or trimmers. The analog input version “type A” is also available as 4 - 20mA input loop powered display (power supply type PL).

<b>A</b>		(0)4 - 20mA sensor input for flow, level, pressure and temperature measurement.
<b>H</b>		Thermocouple input for temperature measurement. Available types: check the latest datasheets.
<b>P</b>		Pulse input for flow applications. Signal types: sine wave (coil), NPN, PNP, reed switch, Namur and active signals. For most signals a low pass filter can be enabled.
<b>T</b>		PT100 (PRTD) input for temperature measurement, suitable for 2 or 3 wire (Fo: 4 wire as well).
<b>U</b>		0 - 10V DC sensor input for flow, level, pressure and temperature measurement.
<b>X</b>		No primary signal input (model F193 only).



## Analog output signal

Available for the F1-Series only: related to the actual flow, level, height, pressure, temperature, percentage, ratio, consumption, differential or sum, position, energy or as control output. *Note: an active analog output comes with an active transistor output type OA and requires a power supply option type PD, PF or PM.*

<b>AA</b>		Active 4 - 20mA analog output - requires OA + PD, PF or PM.
<b>AB</b>		Active 0 - 20mA analog output - requires OA + PD, PF or PM.
<b>AF</b>		Passive floating 4 - 20mA analog output for Intrinsically Safe applications - requires PC, PD or PL.
<b>AI</b>		Passive isolated 4 - 20mA analog output - requires PB, PD, PF, PL or PM.
<b>AP</b>		Passive 4 - 20mA analog output signal. Output loop powered which means that the unit will be powered through this loop (comes with type PX as standard).
<b>AU</b>		Active analog output 0 - 10V DC - requires OA + PD, PF or PM.
<b>AX</b>		No analog output.



## Communication

Available for the F1-Series only: all process data, settings and functions can be read, modified and controlled through the Modbus RTU / ASCII communication link. The selectable communication speed is 1200, 2400, 4800 or 9600 baud and 255 addresses can be assigned. Full Modbus functionality remains available for the Intrinsically Safe version (TTL). *Note: some models do not support Modbus ASCII.*

<b>CB</b>	RS232 - Modbus communication. Maximum cable length 15 meters (50 feet), no multi drop (1:1).
<b>CH</b>	RS485 - 2 wire - Modbus communication. Maximum cable length 1200 meters (3,937 feet), multi drop (1:n).
<b>CI</b>	RS485 - 4 wire (RS422) - Modbus communication. Maximum cable length 1200 meters (3,937 feet), multi drop (1:n).
<b>CT</b>	TTL (RS232 compatible) - Modbus communication, Intrinsically Safe only. No multi drop (1:1). Cable length: the normal RS232 limitations of bandwidth versus cable length are applicable. As a rule of thumb, speed (baud) x length (meters) < 15,000.
<b>CX</b>	No communication option.

## Flow equations

The flow computers F126 and F127 use generic formulas for corrected gas and liquid volume.

<b>EG</b>	Formula for gas applications with temperature and pressure compensation.
<b>EL</b>	Formula for liquid applications with temperature compensation.
<b>EX</b>	No flow equations option.

## Enclosures

Various types of enclosures are available for hazardous and safe area applications. The enclosures have recently been redesigned with a new keyboard and sealing to make them suitable for even the most harsh environments and to improve the operation. All enclosures have stainless steel screws. The aluminum enclosures are painted with a high quality UV stabilized two component industrial paint. The GRP enclosures (Glass-fiber Reinforced Polyamide) are UV stabilized and offer Vo acc. to UL94. New stainless steel accessories are available for wall and pipe mounting of the field enclosures (see section Accessories).

<b>HA</b>	Field / wall mount enclosure	IP67 / NEMA 4X	Aluminum	Cable entry: 2 x PG9 and 1 x M20.
<b>HB</b>	Panel mount enclosure	IP65 / NEMA 4	Aluminum	
<b>HC</b>	Panel mount enclosure	IP65 / NEMA 4	GRP	
<b>HD</b>	Field / wall mount enclosure	IP67 / NEMA 4X	GRP	Cable entry: no holes.
<b>HE</b>	Field / wall mount enclosure	IP67 / NEMA 4X	GRP	Cable entry: 2 x 16mm and 1 x 20mm.
<b>HF</b>	Field / wall mount enclosure	IP67 / NEMA 4X	GRP	Cable entry: 1 x 22mm (0.866").
<b>HG</b>	Field / wall mount enclosure	IP67 / NEMA 4X	GRP	Cable entry: 2 x 20mm.
<b>HH</b>	Field / wall mount enclosure	IP67 / NEMA 4X	GRP	Cable entry: 6 x 12mm.
<b>HM</b>	Field / wall mount enclosure	IP67 / NEMA 4X	Aluminum	Cable entry: 2 x M16 and 1 x M20.
<b>HN</b>	Field / wall mount enclosure	IP67 / NEMA 4X	Aluminum	Cable entry: 1 x M20.
<b>HO</b>	Field / wall mount enclosure	IP67 / NEMA 4X	Aluminum	Cable entry: 2 x M20.
<b>HP</b>	Field / wall mount enclosure	IP67 / NEMA 4X	Aluminum	Cable entry: 6 x M12.
<b>HT</b>	Field / wall mount enclosure	IP67 / NEMA 4X	Aluminum	Cable entry: 1 x 1/2" NPT.
<b>HU</b>	Field / wall mount enclosure	IP67 / NEMA 4X	Aluminum	Cable entry: 3 x 1/2" NPT.
<b>HZ</b>	Field / wall mount enclosure	IP67 / NEMA 4X	Aluminum	Cable entry: no holes.

## Inputs - additional pressure or switch input

Available for the F1-Series only: several products offer or require additional inputs with following functionality:

<b>IA</b>		(0)4 - 20mA input for pressure measurement.
<b>IB</b>		Additional reset input to zero the totalizer.
<b>IU</b>		0 - 10V DC input for pressure measurement.
<b>IX</b>		No additional input.

## Outputs - alarm / pulse / control

Following switch output(s) are related to the totalizer (scaled pulse or alarm output), high / low alarms for flow, level, pressure or temperature or control outputs for the batch controllers. The Fo-Series offers maximum one output. The F1-Series maximum of four outputs, however in case of an Intrinsically Safe application a maximum of two outputs are available. Except the passive transistor (type OT), all output types require a power supply option type PD, PF or PM. For detailed information please consult the product datasheet.

<b>OA</b>		Active 24V transistor output(s), requires type PD, PF or PM. (F1-Series also: AA, AB or AU), max load: 50mA @ 24V DC.
<b>OR</b>		Mechanical SPST relays - isolated, requires type PF or PM, max. load 1A - 230V AC.
<b>OS</b>		Four mechanical SPST relays - isolated, requires type PD, max. load 1A - 230V AC.
<b>OT</b>		Passive transistor output(s), max. load 300mA @ 50V DC, (Intrinsically Safe max. 30V DC 100mA) per output.
<b>OX</b>		No output.

## Power supply

To power the F-Series, several power supply options are available. For detailed information please consult the datasheet of the product.

<b>PB</b>		Long life lithium battery - only one battery required.
<b>PC</b>		Intrinsically Safe lithium battery - only one battery required.
<b>PD</b>		16 - 24V DC power supply with limited sensor supply capabilities.
<b>PF</b>		24V AC / DC power supply with full sensor supply.
<b>PL</b>		Input loop powered, the unit is powered through the 4 - 20mA signal input.
<b>PM</b>		115 - 230V AC power supply with full sensor supply.
<b>PX</b>		Sensor supply not available. Fo-Series can be powered with 8 - 30V DC. F1-Series can be powered by output loop (type AP), voltage: 8 - 30V DC.

## Temperature - additional inputs

Available for the F1-Series only: several products require additional inputs with following functionality.

<b>TA</b>		(0)4 - 20mA input for temperature measurement.
<b>TP</b>		PT100 input for temperature measurement - 2 or 3 wire.
<b>TU</b>		0 - 10V DC input for temperature measurement.
<b>TX</b>		No additional input.



## Hazardous area

All models can be supplied Intrinsically Safe with ATEX Certification. For the Fo-Series IECEx, CSA and FM approval as well as non-incendive approval are expected to become available during 2006. For detailed information and latest information, please consult the datasheet and certificate of the product.

<b>XF</b>		ATEX - EExd flameproof enclosure  II 2 GD EEx d IIB T <sub>5</sub> .
<b>XI</b>		ATEX - Intrinsically Safe:  II 1 GD EEx ia IIB/IIC T <sub>4</sub> T <sub>100</sub> °C.
<b>XN</b>		Non incendive: Expected fourth quarter 2006.
<b>XX</b>		Safe area application.

## Other options

Several other options are listed below. Please be aware that more than one of these options can be selected.

<b>ZB</b>		Bi-color backlight green/amber. In case of a monitoring application, the backlight can be set to switch to red in case of an alarm condition. <i>Note: for the F1-Series, only a green backlight for safe area applications is available at this moment.</i>
<b>ZF</b>		Extra high sensitivity for the sine wave (coil) input 10mV p-p.
<b>ZG</b>		Very high sensitivity for the sine wave (coil) input 5mV p-p.
<b>ZV</b>		PT100 (PRTD) range -200°C to +800°C (-328°F to +1472°F).
<b>ZX</b>		No additional option.

# ENCLOSURES

The following pages contain dimensional drawings of the F-Series enclosures and mounting accessories.

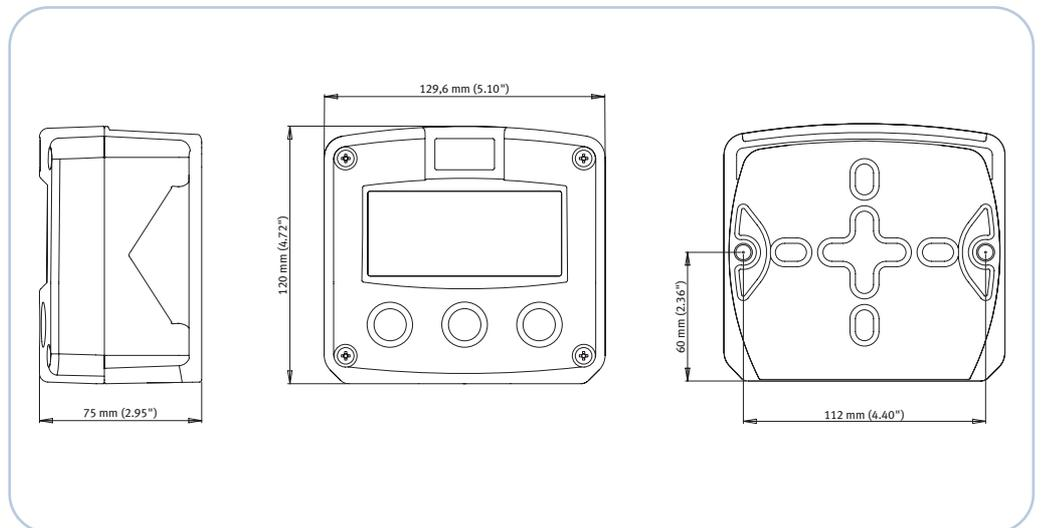

*Field / wall mount enclosures, IP67 / NEMA4X*

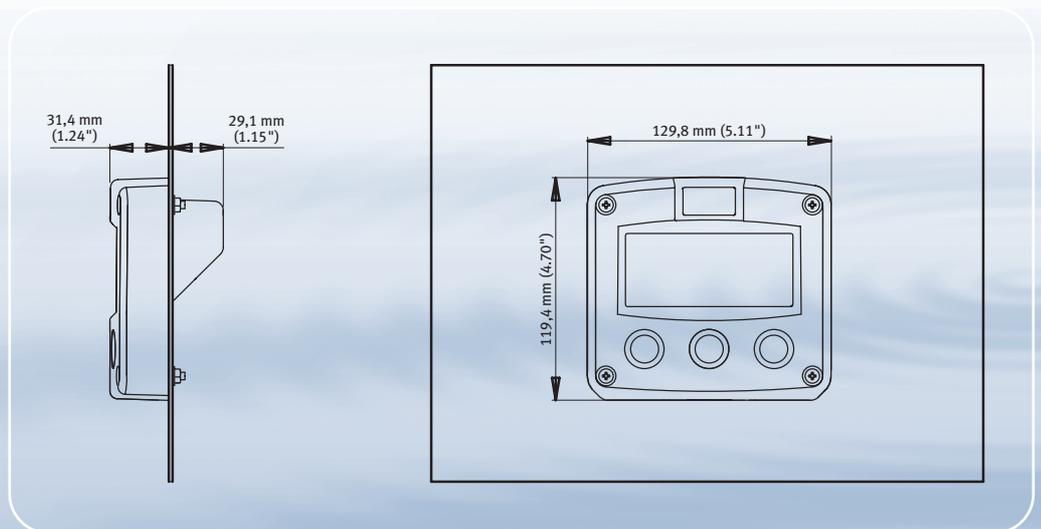

*Panel mount enclosures, IP65 / NEMA4*



## Panel mounting

A major advantage of using the F-Series as a panel mount unit is the minimum depth clearance required. This allows a small box being used compared to many other panel mount devices.

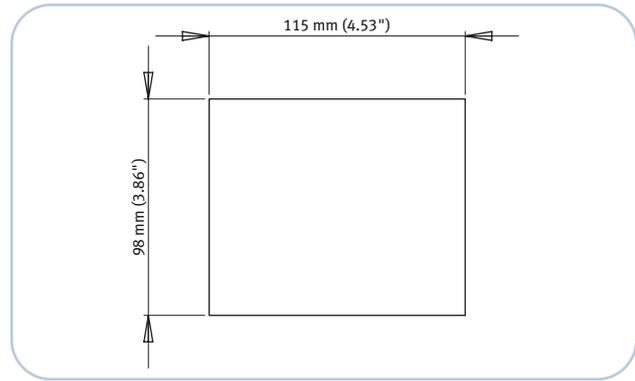

*Panel mount cut-out dimensions*

## Panel cut-out

The panel cut-out can be rectangle where the four bolts will be located in the corners.



## Mounting the enclosure in a panel

The enclosure is supplied with four stainless steel bolts, O-rings, washers and nuts.



## F-Series mounted in the cabinet

After installing the unit, the thick silicon gasket does assure a proper sealing.



## Wall mounting

The F-Series enclosures can be mounted onto the wall in two ways: with and without a mounting plate. Proper screws or bolts have to be used as the weight of the aluminum enclosure is about 1kg and the GRP enclosure about 0.5 kg.

### Mounting **without** a mounting plate;

Two holes have to be drilled horizontally to place 6mm (0.23") screws or bolts.

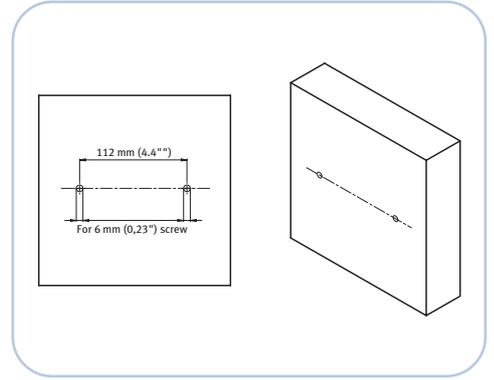

### Mounting **with** a mounting plate

The stainless steel mounting plate does make the installation easier. It includes two proper fixed M6 stainless steel bolts with nuts and a large position to fix a tagplate with 3mm (0.11") screws.

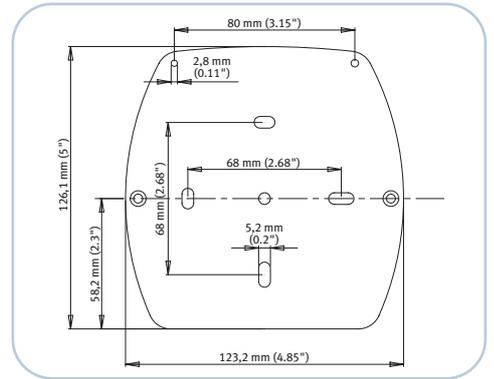

### Placing the mounting plate

Two or four holes have to be drilled horizontally and/or vertically, suitable for 5mm (0.2") screws or bolts.



### Placing the wall mount enclosure

Simply place the unit and fix it with the two stainless steel washers and M6 nuts provided.



## Pipe mounting

The F-Series enclosures can be mounted on any horizontal or vertical pipe from 54,8mm (2") diameter with the stainless steel pipe mounting kit. Proper clamps have to be used as the total weight including the aluminum enclosure is about 1,4 kg and including the GRP enclosure about 0,9 kg. On the top of the mounting plate, a space is provided to place a proper tagplate with 3mm (0.11") screws.

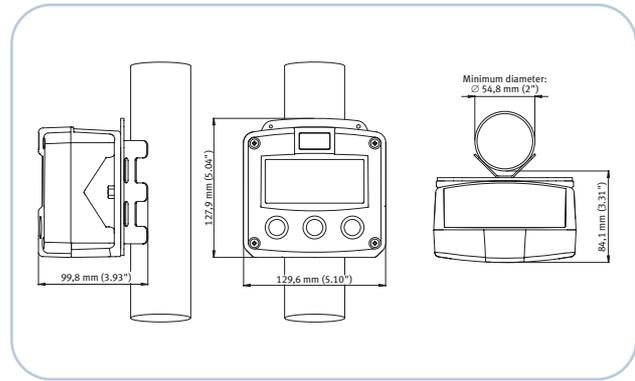

## Assembling the pipe mounting kit

The mounting kit includes three stainless steel M5 bolts to fix the pipe mounting bracket horizontally or vertically on the mounting plate. When assembled, the part can easily be fixed on the pipe with the stainless steel worm gear clamps.



## Placing the field mount enclosure

Simply place the unit and fix it with the two stainless steel washers and M6 nuts provided.



# ACCESSORIES

The following pages contain several accessories, which are available for the F-Series.



## Mounting accessories

<b>ACF02</b>	Stainless steel wall mounting kit includes screws and plugs.
<b>ACF05</b>	Stainless steel pipe mounting kit (worm gear clamps not included).
<b>ACF06</b>	Two stainless steel worm gear clamps Ø 44 - 56mm (1.73" - 2.20").
<b>ACF07</b>	Two stainless steel worm gear clamps Ø 58 - 75mm (2.29" - 2.95").
<b>ACF08</b>	Two stainless steel worm gear clamps Ø 77 - 95mm (3.04" - 3.74").
<b>ACF09</b>	Two stainless steel worm gear clamps Ø 106 - 138mm (4.18" - 5.43").
<b>ACF10</b>	Customized Grevopal tagplates for ACF02 and ACF05, including stainless steel screws. Dimension: 95mm x 12.5mm (3.75" x 0.5").



*Stainless steel pipe mounting kit*

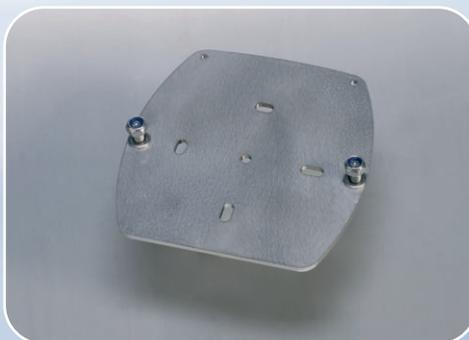

*Stainless steel wall mounting kit*

## Cable gland accessories

<b>ACF20</b>	for HA enclosure: 2 x PG9, 1 x M20 includes O-rings - IP67 / NEMA 4X.
<b>ACF25</b>	for HE enclosure: 2 x M16, 1 x M20 includes locknuts and O-rings - IP67 / NEMA 4X.
<b>ACF26</b>	for HF enclosure: 1 x M20 includes locknut and O-ring - IP67 / NEMA 4X.
<b>ACF27</b>	for HG enclosure: 2 x M20 includes locknuts and O-rings - IP67 / NEMA 4X.
<b>ACF28</b>	for HH enclosure: 6 x M12 includes locknuts and O-rings - IP67 / NEMA 4X.
<b>ACF32</b>	for HM enclosure: 2 x M16, 1 x M20 - includes O-rings - IP67 / NEMA 4X.
<b>ACF33</b>	for HN enclosure: 1 x M20 - includes O-ring - IP67 / NEMA 4X.
<b>ACF34</b>	for HO enclosure: 2 x M20 - includes O-rings - IP67 / NEMA 4X.
<b>ACF35</b>	for HP enclosure: 6 x M12 - includes O-rings - IP67 / NEMA 4X.
<b>ACF39</b>	for HT enclosure: 1 x 1/2" NPT - includes O-ring - IP67 / NEMA 4X.
<b>ACF40</b>	for HU enclosure: 3 x 1/2" NPT - includes O-rings - IP67 / NEMA 4X.



Cable glands

## Blind plug accessories

<b>ACF50</b>	for HA enclosure: 2 x PG9, 1 x M20 includes O-rings - IP67 / NEMA 4X.
<b>ACF55</b>	for HE enclosure: 2 x M16, 1 x M20 includes locknuts and O-rings - IP67 / NEMA 4X.
<b>ACF56</b>	for HF enclosure: 1 x M20 includes locknut and O-ring - IP67 / NEMA 4X.
<b>ACF57</b>	for HG enclosure: 2 x M20 includes locknuts and O-rings - IP67 / NEMA 4X.
<b>ACF58</b>	for HH enclosure: 6 x M12 includes locknuts and O-rings - IP67 / NEMA 4X.
<b>ACF62</b>	for HM enclosure: 2 x M16, 1 x M20 - includes O-rings - IP67 / NEMA 4X.
<b>ACF63</b>	for HN enclosure: 1 x M20 - includes O-ring - IP67 / NEMA 4X.
<b>ACF64</b>	for HO enclosure: 2 x M20 - includes O-rings - IP67 / NEMA 4X.
<b>ACF65</b>	for HP enclosure: 6 x M12 - includes O-rings - IP67 / NEMA 4X.
<b>ACF69</b>	for HT enclosure: 1 x 1/2" NPT - includes O-rings - IP67 / NEMA 4X.
<b>ACF70</b>	for HU enclosure: 3 x 1/2" NPT - includes O-rings - IP67 / NEMA 4X.



Blind plugs

## Intrinsically Safe isolators accessories

Ordering code		Description	Hazardous area	Safe area
ACG01	MTL5011B	One channel pulse or switch output transfer from hazardous area to safe area, including power supply.	type OT: passive transistor	1 mechanic make-and-break relay
ACG02	MTL5025	One channel power supply from safe area to hazardous area (e.g. to power the unit with type PD or to power a switching or analog device in hazardous area).	device to be powered	20 - 35V DC
ACG03	MTL5042	One channel 4 - 20mA repeater from hazardous area to safe area, including power supply.	type AP / AF: passive analog output	floating 4 - 20mA
ACG04	MTL5051	Bi-direction serial-data isolator (for Modbus communication).	type CT: TTL	RS232, RS422 or TTL
ACG05	MTL5018	Two channel pulse or switch output transfer from hazardous area to safe area, including power supply.	type OT: transistor	2 mechanic make-and-break relays
ACG06	MTL5012	One channel pulse or switch output transfer from hazardous area to safe area, including power supply.	type OT: passive transistor	floating solid state
ACG07	MTL5045	One channel isolated driver bringing 4 - 20mA from safe area to hazardous area, including power supply.	active 4 - 20mA	4 - 20mA



MTL isolators







**Fluidwell bv**  
P.O. Box 6  
5460 AA VEGHEL  
The Netherlands

Phone +31 (0)413 343 786

Fax +31 (0)413 363 443

[sales@fluidwell.com](mailto:sales@fluidwell.com)

[www.fluidwell.com](http://www.fluidwell.com)

**Distributor:**



*Important: specifications are subject to change without notice. Copyright Fluidwell bv - 2011 - FSERIES-CATALOG-EN-V1152*