

# Harmonic Drive LLC

Precision Actuators • Gearheads • Gearing Components

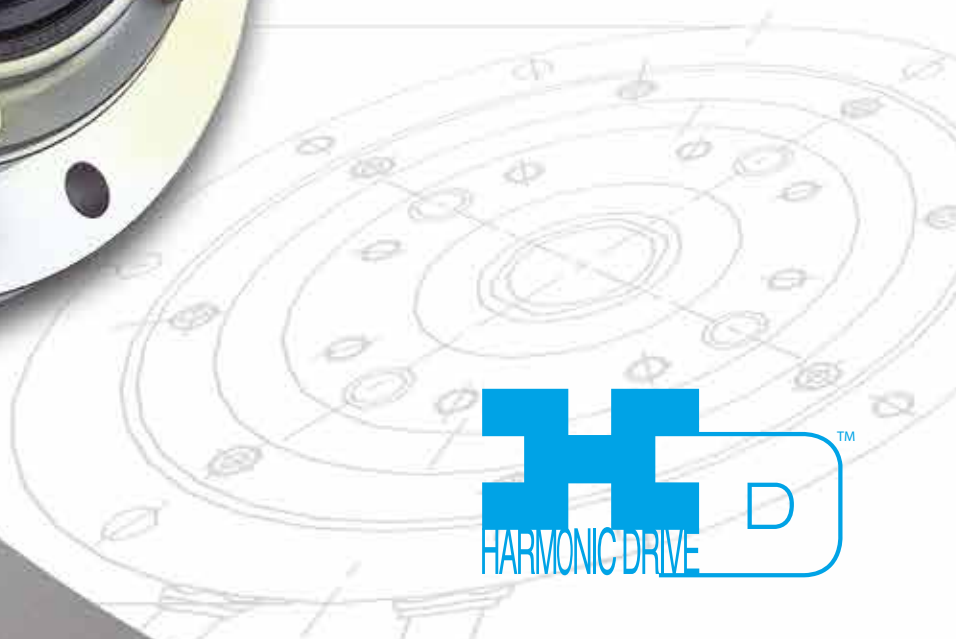

Total  
Motion  
Control

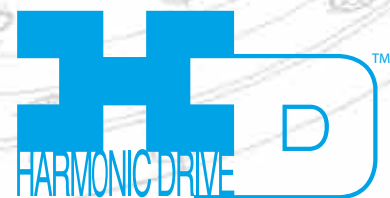

# Excellent Technology for Evolving Industries

Harmonic Drive® actuators utilize high-precision, zero-backlash Harmonic Drive® precision gears and play critical roles in robotics, semiconductor manufacturing equipment, factory automation equipment, medical diagnostics and surgical robotics. Additionally, our products are frequently used in mission-critical spaceflight applications which capture the human spirit.

With over 50 years of experience, our expert engineering and production teams continually develop enabling technologies for the evolving motion control market. We are proud of our outstanding engineering capabilities and successful history of providing customer specific solutions to meet their application requirements.

Harmonic Drive LLC continues to develop enabling technologies for the evolving motion control market, which drives the pace of global innovation.

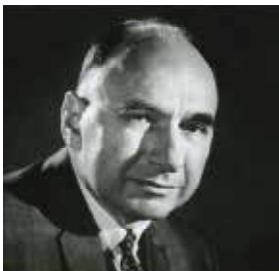

C. Walt Musser  
Patented Strain Wave Gearing  
in 1955

# Harmonic Drive® High-Precision Strain Wave Gearing

## Features

- Zero backlash
- High positioning accuracy
- High repeatability
- Compactness
- Light weight
- High reduction ratio
- High torque capacity
- High efficiency
- Quiet operation

## Structure

Utilizing a unique operating principle, the gear consists of only 3 basic parts (Wave Generator, Flexspline, and Circular Spline). It provides excellent features not found in other speed reducers.

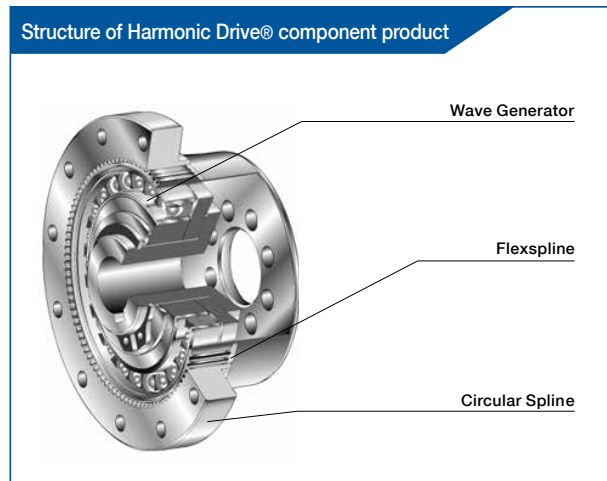

### Wave Generator

The Wave Generator is a thin raced ball bearing fitted onto an elliptical hub. This serves as a high efficiency torque converter and is generally mounted onto the input or motor shaft.

### Flexspline

The Flexspline is a non-rigid, thin cylindrical cup with external teeth on the open end of the cup. The Flexspline fits over the Wave Generator and takes on its elliptical shape. The Flexspline is generally used as the output of the gear.

### Circular Spline

The Circular Spline is a rigid ring with internal teeth. It engages the teeth of the Flexspline across the major axis of the Wave Generator ellipse. The Circular Spline has two more teeth than the Flexspline and is generally mounted onto a housing.

## Operating Principle

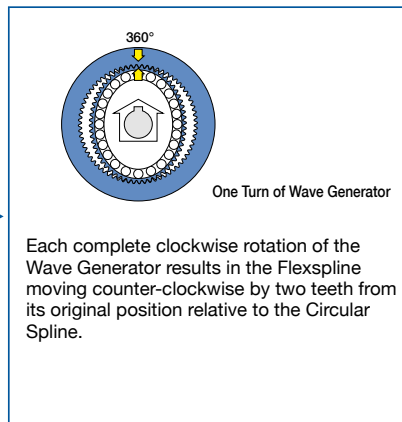
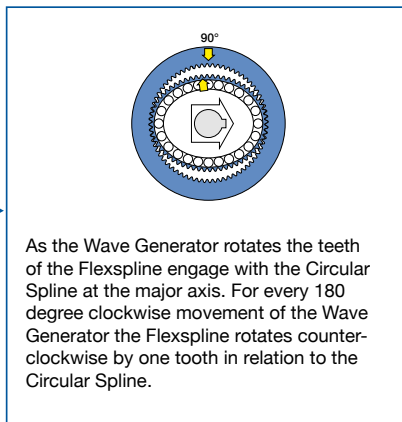
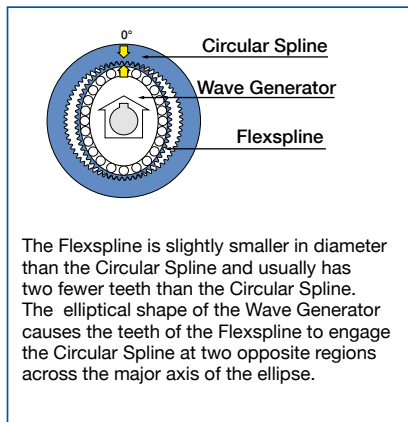

## Tooth engagement

The strain wave gear has a unique tooth engagement which results in a Zero-backlash gear mesh that provides high positional accuracy and high torque with a compact form factor.

The Harmonic Drive® strain wave gear utilizes a unique gear tooth profile for optimized tooth engagement. Unlike an involute tooth profile, which is used in conventional gears, this optimized tooth profile ("S tooth") enables about 30% of the total number of teeth to be engaged at the same time. This technological innovation results in high torque, high torsional stiffness, long life and smooth rotation.

The "S" tooth profile eliminates stress concentration by widening the tooth root and providing a large tooth root radius. This figure shows the progression of the Flexspline tooth engagement as it meshes with the teeth of the fixed Circular Spline.

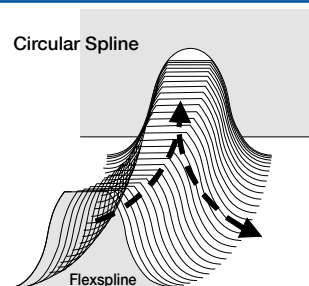

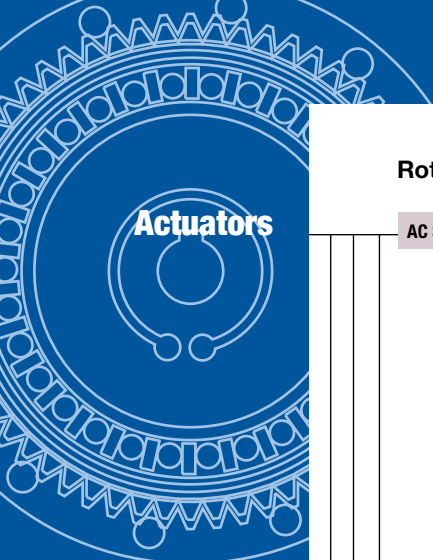

# Actuators

## Rotary Actuators

			Specification (range)	
			Peak Torque (Nm)	Maximum Speed (rpm)
AC Servomotors	Miniature Flat Hollow Shaft	FHA-Cmini	1.8~28	60~200
	Flat Hollow Shaft	FHA-C	39~820	22~96
	Flat Hollow Shaft	FHA-C PR	39~820	22~96
	Flat Hollow Shaft	SHA	73~3419	17.4~117.6
	Hollow Shaft	SHA-CG	23~3419	25~120
	Ultra Compact Cylinder	RSF Supermini	0.13~1.4	100~333
	Compact Cylinder	RSF mini	1.8~28	60~200
	Compact Cylinder	RSF	34~330	45~90
	Compact Cylinder	RKF	56~330	45~90
DC Servomotors	Compact Cylinder	RH	0.39~20	50~180
Direct Drive Motor	Ultra Precision Direct Drive Motor	KDU	7.0~15.0	160~180
Hollow Shaft Motor	Ultra Precision Hollow Shaft	MA	1.8~45	3000~6000

## Linear Actuators

			Maximum Driving Force (N)	Maximum Speed (mm/s)	Stroke (mm)
AC Servomotor	High-Force Positioning	LBC	6000~12000	10~20	50
DC Servomotors	Low-Force Positioning	LA	49	0.9	10~30
	Medium-Force Positioning	LAH-46	392	3.7	10~30
Stepping Motors	High-Force Positioning	LAH-80	3000	3000	0.9~10

## Other Actuators

			Moment of Inertia (g.cm <sup>2</sup> )	Torque Constant (N·m/A(rms))
Optical Galvano Scanners	High Accuracy, High Response	LSA	1.9~8.5	0.0082~0.05

## Sensors

Super-Compact Encoders, Micro Encoders	Micro Encoder
--	---------------

## Servo Drivers

			Pulse Position Command	Analog Speed Command	Mono-shaft Control (Command)	Interface to Absolute Encoder	Interface to Incremental Encoder
DC Digital Servo Drive	Multiple Operating Modes	DCJ Series	•	•	•	—	•
	Multiple Operating Modes	DDP Series	•	•	•	—	•
	Multiple Operating Modes	DEP Series	—	•	•	•	•
AC Digital Servo Drive	Multiple Communication Modes	RTL Series	•	•	•	—	•
	Multiple Operating Modes	REL Series	•	•	•	•	•
For AC Servomotors	Position and Speed Control	HA-680 Series	•	•	—	—	•
	Field Boss	HA-800 Series	•	—	—	•	•
	Field Boss	HA-680CL Series	•	—	—	—	•
	Field Boss	HA-680ML Series	•	•	—	—	•
For Direct Drive Motor	Position Control Only	HA-770 Series	•	—	—	—	•

The combinations with actuator and driver may not comply with foreign safety standards. Please contact our sales office.





FHA-C mini (Page 8)



FHA-C (Page 9)



FHA-C PR (Page 10)



SHA-CG (Page 12)



SHA (Page 14)



RSF Supermini (Page 16)



RSF Mini (Page 17)



RSF (Page 18)



RKF (Page 19)



RH Mini Series  
(Page 20)



KDU (Page 21)



MA Motor (Page 22)



LBC (Page 23)



LA (Page 24)



LAH-46 (Page 25)



LAH-80 (Page 25)



LSA (Page 26)

Custom actuators also available. Contact us to find out more about our engineering design services.



Micro Encoder (Page 27)



DDP  
(Pages 28-29)



DCJ  
(Pages 28-29)



DEP  
(Pages 28-29)



RTL/REL  
(Pages 28-29)



HA-800  
(Page 30)



HA-680  
(Page 31)



HA-680ML  
(Page 31)



HA-680CL  
(Page 31)

Field Boss Options



# Speed Reducers

## Harmonic Drive® Precision Product

Component			Peak Torque (Nm)	Reduction Ratio			
<b>Component Gear Sets</b> Consisting of three basic components: flexspline, circular spline and wave generator; component gear sets offer ultimate design flexibility and can be tightly integrated in equipment sub-structures.	Cup	Standard	CSF	1.8~9200	30:1~160:1		
		High-Torque	CSG	23~3400	50:1~160:1		
		Ultra-Flat	CSD	12~820	50:1~160:1		
	Pancake	Standard	FB	7.8~330	50:1~160:1		
		High-Torque	FR	9.8~4000	50:1~320:1		
	Silk Hat	Standard	SHF	9.0~1800	30:1~160:1		
		High-Torque	SHG	23~3400	50:1~160:1		
	<b>Gear Unit</b> Housed component gearing combined with precision cross roller output bearing & flange. Very compact, robust and easy to use gearhead solution.	Cup	Standard	CSF-2UH	9.0~2600	30:1~160:1	
			Standard, Lightweight	CSF-2UH-LW	9.0~2600	30:1~160:1	
High-Torque			CSG-2UH	23~3400	50:1~160:1		
High-Torque, Lightweight			CSG-2UH-LW	23~3400	50:1~160:1		
High-Torque, Full Unit			CSG-2UK	127~3400	50:1~160:1		
Ultra-Flat			CSD-2UH	12~823	50:1~160:1		
Ultra-Flat			CSD-2UF	12~453	50:1~160:1		
Compact Mini			CSF-2XH	0.5~28	30:1~160:1		
Compact Mini, Double Shaft			CSF-1U	0.13~28	30:1~160:1		
Mini, Ultra-Flat			CSF-2UP	1.8~28	30:1~100:1		
Silk Hat		Hollow Shaft	SHF-2UH	8.3~1800	30:1~160:1		
		Hollow Shaft, Lightweight	SHF-2UH-LW	9.0~1800	30:1~160:1		
		High-Torque, Hollow Shaft	SHG-2UH	23~3400	50:1~160:1		
		High-Torque, Hollow Shaft, Lightweight	SHG-2UH-LW	23~3400	50:1~160:1		
		Input Shaft	SHF-2UJ	9.0~1800	30:1~160:1		
		High-Torque, Input Shaft	SHG-2UJ	23~3400	50:1~160:1		
		Ultra-Flat, Hollow Shaft, Lightweight	SHD-2UH-LW	12~450	50:1~160:1		
		Simplicity Gear Unit	Silk Hat	Ultra-flat, Hollow shaft	SHD-2SH	12~450	50:1~160:1
				Hollow Shaft	SHF-2SH	9.0~1800	30:1~160:1
				High-torque, Hollow shaft	SHG-2SH	23~3400	50:1~160:1
Input coupling	SHF-2SO			9.0~1800	30:1~160:1		
High-torque, Input coupling	SHG-2SO			23~3400	50:1~160:1		
<b>Phase Adjustment Unit</b>	Coupling Indexer	Manual Phase Adjuster	HDI	100~500	100:1		
		Pancake	Differential	FD	23~3400	80:1~320:1	
			1:1 Differential	FBB	28~655	80:1~160:1	

# Quick Connect™

## Planetary Gearing

			Peak Torque (Nm)	Reduction Ratio	Motor Capacity (W)	
Gearhead	Cup	Standard	CSF-GH	18~2600	50:1~160:1	30~5000
		High-torque	CSG-GH	23~3400	50:1~160:1	30~5000
Gearhead		Standard	HPG	5~3200	3:1~50:1	10~15000
		High-torque	HPGP	12~3940	4:1~45:1	10~15000
		Helical	HPG-R	5~400	3:1~10:1	10~15000
		Standard Right Angle	HPG -RA	150~2200	5:1~50:1	500~8000
		Value	HPN	9~752	3:1~31:1	30~7500
		Hollow shaft	HPF	100~220	11:1	500~2000



CSF (Page 34)



CSG (Page 35)



CSD (Page 36)



FB (Page 37)



FR (Page 37)



SHF (Page 38)  
SHG (Page 39)



CSF-2UH  
(Page 40)



CSG-2UH  
(Page 42)



CSF -2UH-LW (Pg 41)  
CSG -2UH-LW (Pg 43)



CSG-2UK  
(Page 44)



CSD-2UH  
(Page 46)



CSD-2UF  
(Page 47)



CSF mini  
(Page 48)



CSF-2UP  
(Page 49)



SHF-2UH (Pg 50)  
SHG-2UH (Pg 52)



SHF-2UJ (Page 50)  
SHG-2UJ (Page 52)



SHF -2UH-LW (Pg 51)  
SHG -2UH-LW (Pg 53)



SHD-2UH-LW  
(Page 54)



SHD-2SH (Page 55)



SHF-2SH (Page 56), SHG-2SH (Page 57)



SHF-2SO (Page 56), SHG-2SO (Page 57)



FD Series Component Type (Page 58)



FD Series Unit Type (Page 59)



FBB (Page 60)



HDI Phase Adjuster (Page 61)



CSF-GH (Page 62)  
CSG-GH (Page 63)



HPG (Page 64)  
HPG-R (Page 65)



HPGP (Page 66)



HPG RA (Page 67)



HPN (Page 68)



HPF (Page 69)

## Hollow Shaft Brushless Actuators FHA-C Mini Series



These servo actuators utilize Harmonic Drive® precision gears combined with a performance matched brushless servomotor and incremental encoder. The cube shaped form factor is very compact and features a through hole in the center of the shaft. This hollow shaft may be used to pass cables, tubing or a laser beam through the axis of rotation.

The FHA-mini series is designed to operate with a wide range of third-party drivers, as well as Harmonic Drive LLC's DDP Series, DCJ Series, and DEP Series.

- Large center through hole
- Compact design
- Body width from 50 mm to 75 mm
- Body length from 48.5 mm to 66 mm

### •FHA-C mini Series Ratings

Item		Model	FHA-8C			FHA-11C			FHA-14C		
Gear Ratio			30	50	100	30	50	100	30	50	100
Maximum Torque <sup>2</sup>		Nm	1.8	3.3	4.8	4.5	8.3	11	9	18	28
		in-lb	15.9	29.2	42.5	39.8	73.5	97.4	79.7	159.3	247.8
Maximum Positioning Speed		rpm	200	120	60	200	120	60	200	120	60
Torque Constant 100V, 200V		Nm/A (rms)	3.9	6.7	14	3.8	6.6	13	4.2	7.2	15
		in-lb/A (rms)	34.5	59.3	123.9	33.6	58.4	115.1	37.2	63.7	132.8
Torque Constant 24V		Nm/A (rms)	0.8	1.3	2.7	0.8	1.3	2.6	0.8	1.4	2.9
		in-lb/A (rms)	7.1	11.5	23.9	7.1	11.5	23.0	7.1	12.4	25.7
Maximum Current <sup>2</sup>	AC100V, 200V	A(rms)	0.61	0.64	0.48	1.5	1.6	1.1	2.9	3.2	2.4
	DC 24V		3.0	3.3	2.4	7.8	8.2	5.6	14.8	16.4	12.3
Moment of Inertia	(GD <sup>2</sup> /4) (J)	kg•m <sup>2</sup>	0.0026	0.0074	0.029	0.0060	0.017	0.067	0.018	0.050	0.20
		kg•cm•s <sup>2</sup>	0.027	0.075	0.30	0.061	0.17	0.68	0.18	0.51	2.0
One-Way Positioning Accuracy		arc/sec	150	120	120	120	90	90	120	90	90
Allowable Moment Load		Nm	15			40			75		
		in-lb	133			354			664		
Moment Stiffness		Nm/rad	2x10 <sup>4</sup>			4x10 <sup>4</sup>			8x10 <sup>4</sup>		
		in-lb/rad	18x10 <sup>4</sup>			35x10 <sup>4</sup>			71x10 <sup>4</sup>		
Quad Encoder Resolution (At x 4) <sup>3</sup>		Pulses/Revolution	240,000	400,000	800,000	240,000	400,000	800,000	240,000	400,000	800,000
Power Supply		V	DC 24, AC 100, AC 200								
Weight		kg	0.40			0.62			1.2		
Protection			Totally closed, self-cooling (Equivalent to IP44)								
Environmental Conditions			Operating temperature: 0 to 40°C • Storage temperature: -20 to +60°C. Operating and storage humidity: 20 to 80% RH (No condensation permitted). Vibration resistance : 25m/s <sup>2</sup> (frequency: 10 to 400Hz) • Shock resistance: 300m/s <sup>2</sup> . Indoor installation: No dust, no metal powder, no corrosive gas, no inflammable gas, no oil mist, no other foreign matter and no direct sunshine. Altitude 1000m or less. Insulation resistance: 100MΩ or higher (DC 500V). Dielectric strength: AC 1500V/1min. Insulation class: Class B								
Recommended Driver		DC24V	DCJ-055-09/DDP-090-09/DEP-090-09			DCJ-055-18/DDP-090-18/DEP-090-18			DDP-090-36/DEP-090-36		
		AC100/200	RTL-230-18/REL-230-18								

1 The figures in the table are those at the output shaft.

2 The figures are typical values.

3 The quad encoder resolution is obtained by the formula (motor encoder resolution) x4 x (reduction ratio).

Unit: mm

Model	A	B	øC	øD
FHA-8C	50	48.5	33.5	6.2
FHA-11C	60	56	41	8
FHA-14C	75	66	52.5	13.5

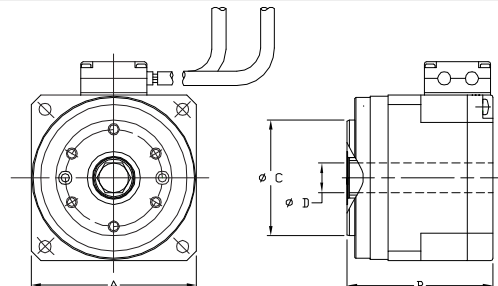



# Hollow Shaft Brushless Actuators FHA-C Series



These servo actuators utilize Harmonic Drive® precision gears combined with a performance matched brushless servo motor and incremental encoder. The FHA has a low profile form factor and features a hollow shaft through the center of the output. This hollow shaft feature may be used to pass cables, tubing or a laser beam through the axis of rotation.

The FHA series is designed to operate with a wide range of third-party drivers, as well as Harmonic Drive LLC's DDP Series, DEP Series, and RTL Series.

- High torque
- Large center through hole
- Compact cylindrical design

## FHA-C Series Ratings

Item		Model			FHA-17C			FHA-25C			FHA-32C			FHA-40C			
Gear Ratio		50	100	160	50	100	160	50	100	160	50	100	160	50	100	160	
Maximum Torque <sup>2</sup>	Nm	39	57	64	150	230	260	281	398	453	500	690	820				
	in-lb	345	504	566	1328	2036	2301	2487	3522	4009	4425	6107	7257				
Maximum Rotational Speed		rpm	96	48	27	90	45	28	80	40	25	70	35	22			
Torque Constant	Nm/A (rms)	21	42	67	22	45	72	27	54	86	31	64	102				
	in-lb/A (rms)	186	372	593	195	398	637	239	478	761	274	566	903				
Maximum Current <sup>2</sup>		A (rms)	2.1	1.6	1.1	7.3	5.6	4.0	11.4	8.0	5.9	17.3	11.8	9.0			
Moment of Inertia	(GD <sup>2</sup> /4)	kg•m <sup>2</sup>	0.17	0.67	1.7	0.81	3.2	8.3	1.8	7.1	18.1	4.9	19.5	50			
	(J)	kgf•cm•s <sup>2</sup>	1.7	6.9	17	8.3	33	85	18	72	185	50	200	510			
One-Way Positioning Accuracy		arc/sec	60	40	40	40	30	30	40	30	30	40	30	30			
Allowable Moment Load	Nm	188			370			530			690						
	in-lb	1664			3275			4691			6107						
Moment Stiffness	Nm/rad	220x10 <sup>3</sup>			490x10 <sup>3</sup>			790x10 <sup>3</sup>			1400x10 <sup>3</sup>						
	in-lb/rad	1947x10 <sup>3</sup>			4337x10 <sup>3</sup>			6992x10 <sup>3</sup>			12390x10 <sup>3</sup>						
Quad Encoder Resolution (At x 4) <sup>3</sup>		Pulses/Revolution	500,000	1,000,000	1,600,000	500,000	1,000,000	1,600,000	500,000	1,000,000	1,600,000	500,000	1,000,000	1,600,000			
Power Supply		V	DC 24V, AC 100, AC 200			AC 100, AC 200			AC 100, AC 200			AC 200					
Weight		kg	2.5			4.0			6.5			12					
Protection		Totally closed, self-cooling (Equivalent to IP44)															
Environmental Conditions		Operating temperature: 0 to 40°C/Storage temperature: -20 to 60°C • Operating and storage humidity: 20 to 80% RH (no condensation permitted). Insulation resistance: 100MΩ (DC 500V) • Dielectric strength: AC 1500V/1min. Vibration resistance: 24.5m/s <sup>2</sup> (frequency: 10 to 400Hz) • Shock resistance: 294m/s <sup>2</sup> . Indoor installation: No dust, no metal powder, no corrosive gas, no oil mist, no other foreign matter and no direct sunshine • Altitude 1000m or less.															
Recommended Driver	DC 24V	DDP-090-36/DEP-090-36															
	AC 100	RTL-230-18/REL-230-18			RTL-230-36 REL-230-36	RTL-230-18 REL-230-18	RTL-230-36 REL-230-36	RTL-230-18 REL-230-18									
	AC 200	RTL-230-18/REL-230-18									RTL-230-36 REL-230-36	RTL-230-18 REL-230-18					

1 The figures in the table are those at the output shaft.

2 The figures are typical values.

3 The quad encoder resolution is obtained by the formula (motor encoder resolution) x4 x (reduction ratio).

Please refer to the manual for details.

Unit: mm

Size Symbol	FHA-17C	FHA-25C	FHA-32C	FHA-40C
øA	128	155	175	230
øB	70	85	105	130
øC	18	32	35	45
D	21	25	22	30
E	78	90.5	111.5	127

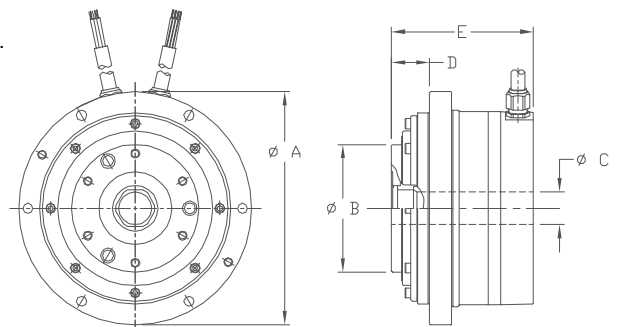

## Hollow Shaft Brushless Actuators FHA-C PR Series



FHA-C-PR features improved one way and bi-directional positioning repeatability and is ideal for high-precision rotary positioning. These servo actuators utilize Harmonic Drive® precision gears combined with a performance matched brushless servo motor and incremental encoder. The FHA has a low profile form factor and features a hollow shaft through the center of the output. This hollow shaft feature may be used to pass cables, tubing or a laser beam through the axis of rotation.

The FHA series is designed to operate with a wide range of third-party drivers, as well as Harmonic Drive LLC's DDP Series, DEP Series, and RTL Series.

- High torque
- Large center through hole
- Compact cylindrical design

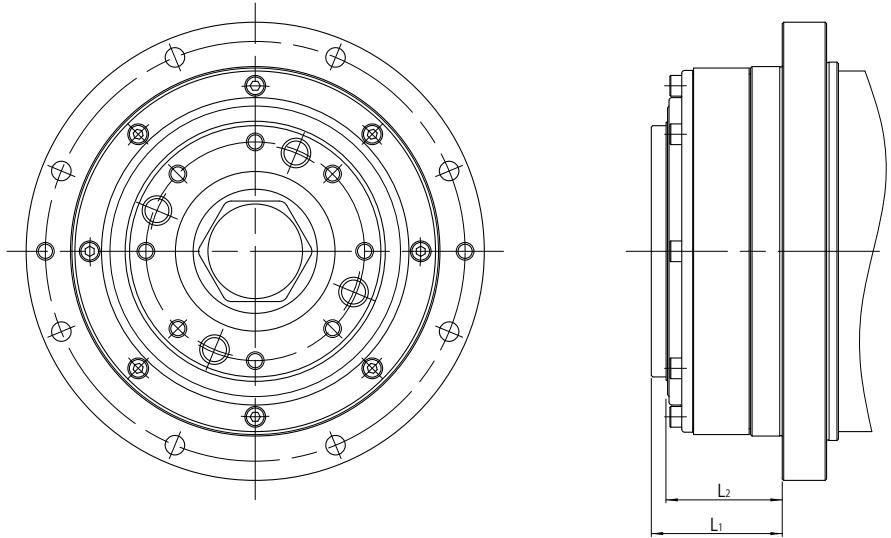

### • Dimensions

(Unit: mm)

Actuator model	FHA-17C-PR	FHA-25C-PR	FHA-32C-PR	FHA-40C-PR
Dimension L <sub>1</sub>	35	44.3	46	58.5
Dimension L <sub>2</sub>	29.5	39.3	41	51.5

### • Mechanical Accuracy

The FHA-C-PR mechanical accuracies of the output shaft and mounting flange are shown below:

(Unit: mm)

Feature	FHA-17C-PR	FHA-25C-PR	FHA-32C-PR	FHA-40C-PR
1. Output shaft surface runout	0.010	0.012	0.012	0.014
2. Output shaft axial runout	0.010	0.012	0.012	0.014
3. Parallelism between output shaft and mounted surface	0.040	0.050	0.050	0.060
4. Concentricity between output shaft and fitting part	0.040	0.050	0.050	0.060

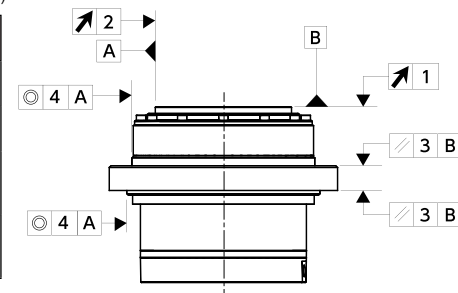

Note: For information on the measurement method, refer to the "FHA-C Series Technical Manual."

Note: Values are based on the Total Indicator Reading (T.I.R.).

# Hollow Shaft Brushless Actuators FHA-C PR Series

## •FHA-C PR Series Ratings

"200V" and "100V" in the table are referred to as the 200V specification (standard) and the 100V specification (option), respectively.

		Model Ratio	FHA-17C-PR			FHA-25C-PR			FHA-32C-PR			FHA-40C-PR		
			50	100	160	50	100	160	50	100	160	50	100	160
Maximum torque	N•m		39	57	64	150	230	260	281	398	453	500	690	820
	in-lb		345	504	566	1328	2036	2301	2487	3522	4009	4425	6107	7257
Maximum speed	rpm		96	48	30	90	45	28	80	40	25	70	35	22
Torque constant	200V	N•m/A (rms)	21	42	67	22	45	72	27	54	86	31	64	102
	100V	N•m/A (rms)	11	21	33	11	22	36	13	27	43	-	-	-
Maximum current <sup>2</sup>	200V	A	2.1	1.6	1.1	7.3	5.6	4.0	11.4	8.0	5.9	17.3	11.8	9.0
	100V	A	4.2	3.2	2.2	15	11	8.0	23	16	12	-	-	-
EMF voltage constant	200V	V/(rpm)	2.3	4.7	7.5	2.5	5.1	8.1	3.0	5.9	9.5	3.6	7.2	11.4
	100V	V/(rpm)	1.2	2.4	3.8	1.3	2.6	4.1	1.5	3.0	4.8	-	-	-
Phase resistance	200V	Ω (20°C)	7.9			2.6			1.0			0.73		
	100V	Ω (20°C)	2.0			0.65			0.25			-		
Phase inductance	200V	mH	6.0			2.6			1.3			1.5		
	100V	mH	1.5			0.65			0.33			-		
Moment of inertia	(GD <sup>2</sup> /4)	kg•m <sup>2</sup>	0.21	0.83	2.1	0.90	3.5	9.2	2.1	8.2	21	5.5	22	56
	(J)	kgf•cm•s <sup>2</sup>	2.1	8.5	21	9	37	94	21	84	215	56	223	569
Allowable radial load	kN		2.9			4.9			9.5			14.7		
	kgf		300			500			970			1500		
Allowable axial load	kN		9.8			14.7			24.5			39.2		
	kgf		1000			1500			2500			4000		
Max. moment load	N•m		188			370			530			690		
	kgf•m		19			38			54			70		
Moment stiffness	N•m/rad		220×10 <sup>3</sup>			490×10 <sup>3</sup>			790×10 <sup>3</sup>			1400×10 <sup>3</sup>		
	kgf•m/arc-min		6.5			15			23			42		
One-way positioning accuracy	arc-sec		60	40	40	40	30	30	40	30	30	40	30	30
One-way repeatability	arc-sec		±5			±5			±4			±4		
Bi-directional repeatability	arc-sec		75	30	30	60	25	25	50	20	20	50	20	20
Motor encoder			2500 counts / revolution											
Quad encoder resolution <sup>3</sup>	Pulse/rev		500,000	1,000,000	1,600,000	500,000	1,000,000	1,600,000	500,000	1,000,000	1,600,000	500,000	1,000,000	1,600,000
Mass	kg		2.8			4.7			7.1			13.6		
Enclosure			Totally enclosed self-cooling (IP44)											
Environmental conditions			Operating temperature: 0 to 40°C/storage temperature: -20 to 60°C Operating humidity / storage humidity: 20 to 80%RH (no condensation) Vibration resistance: 24.5m/s <sup>2</sup> (frequency: 10 to 400Hz) / shock resistance: 294 m/s <sup>2</sup> Do not expose to dust, metal powder, corrosive gas, flammable gas, or oil mist. Use indoors, and do not expose to direct sunlight. Altitude: 1000 m or lower above sea level											
Motor insulation			Insulation resistance: 100MΩ or higher (500 VDC), Withstanding voltage: AC1500V/1min, Insulation class: Type F											
Mounting direction			All position											
Combination servo driver	200V		HA-800*-3C-200			HA-800*-3C-200			HA-800*-6C-200			HA-800*-6C-200		
	100V		HA-800*-3C-100			HA-800*-6C-100			HA-800*-6C-100			-		

1 The values in the table above are referred to as typical values for the output shaft.

2 The value when used with the HA-800 driver.

3 Quadrature resolutions are obtained by (motor encoder resolution x 4) x (reduction ratio)

## Hollow Shaft Brushless Actuators

## SHA-CG Series



SHA-CG high precision actuators are a great alternative for direct drive motors. SHA-CG actuators offer direct drive motor performance in a compact, significantly lighter package. The SHA-CG offers improved rotary positioning accuracy and a high precision output with surface runout less than 10 microns.

- Alternative to Direct Drive Motors
- High Accuracy Output Bearing
- Available with Mounting Base
- High Torque
- Hollow Shaft Design
- Compact
- Available in 4 sizes

## •SHA-CG Series Ratings

Item	Model	SHA20A					SHA25A (Motor voltage 100V)					SHA25A (Motor voltage 200V)				
		50	80	100	120	160	50	80	100	120	160	50	80	100	120	160
Gear Ratio		50	80	100	120	160	50	80	100	120	160	50	80	100	120	160
Maximum Torque <sup>*1</sup>	Nm	73	96	107	113	120	127	178	204	217	229	127	178	204	217	229
	in-lb	642	850	947	100	1062	1124	1575	1805	1920	2027	1124	1575	1805	1920	2027
Maximum Rotational Speed	rpm	120	75	60	50	37.5	96	60	48	40	30	112	70	56	46.7	35
Torque Constant	Nm/A(rms)	16	26	33	39	53	10.9	17.7	22	27	35	19	31	38	46	61
	in-lb/A(rms)	142	230	292	345	469	97	157	195	239	308	168	274	336	407	540
Maximum Current <sup>*1</sup>	A(rms)	6.1	5	4.6	4.1	3.4	15.1	13.2	12.2	11	9	8.7	7.6	7	6.3	5.2
Moment of Inertia GD <sup>2</sup> /4 (without brake) J	kg•m <sup>2</sup>	0.21	0.53	0.82	1.2	2.1	0.5	1.3	2	2.9	5.1	0.5	1.3	2	2.9	5.1
	kgf•cm•s <sup>2</sup>	2.1	5.4	8	12	22	5.1	13	20	29	52	5.1	13	20	29	52
Moment of Inertia GD <sup>2</sup> /4 (with brake) J	kg•m <sup>2</sup>	0.23	0.6	0.94	1.3	2.4	0.6	1.5	2.4	3.4	6.1	0.6	1.5	2.4	3.4	6.1
	kgf•cm•s <sup>2</sup>	2.4	6.1	9.6	14	24	6.1	16	24	35	62	6.1	16	24	35	62
One-Way Positioning Accuracy	arc•sec	60	50	50	50	50	50	40	40	40	40	50	40	40	40	40
Allowable Moment Load	Nm	187					258									
	in-lb	1655					2283									
Moment Stiffness	Nm/rad	25.2×10 <sup>4</sup>					39.2×10 <sup>4</sup>									
	in-lb/rad	7.5					11.6									
Output Resolution	Pulses/Revolution	6,553,600	10,485,760	13,107,200	15,728,640	20,971,520	6,553,600	10,485,760	13,107,200	15,728,640	20,971,520	10,485,760	13,107,200	15,728,640	20,971,520	15,859,712
Power Supply #4	V	200V					100V					200V				
Mass (without brake)	kg	2.6					3.95									
Mass (with brake)	kg	2.7					4.1									
Protection Structure		Enclosed, self-cooled (IP54)														
Environmental Conditions		Operating temperature: 0 to 40°C • Storage temperature: -20 to +60°C. Operating and storage humidity: 20 to 80% RH (No condensation permitted). Vibration resistance : 25m/s <sup>2</sup> (frequency: 10 to 400Hz) • Shock resistance: 300m/s <sup>2</sup> . Indoor installation: No dust, no metal powder, no corrosive gas, no inflammable gas, no oil mist, no other foreign matter and no direct sunshine. Altitude 1000m or less. Insulation resistance: 100MΩ or higher (DC 500V). Dielectric strength: AC 1500V/1min. Insulation class: Class E														
Recommended Driver		REL-230-18, HA-800-3D/E-200					REL-230-18, REL-230-36, HA-800-6D/E-100 <sup>*1</sup>					REL-230-18, REL-230-36, HA-800-3D/E-200				
Encoder Type		Magnetic absolute encoder					Magnetic absolute encoder									

The table shows typical output values of actuators.

\*1 Typical characteristics when combined with our drivers.



# Hollow Shaft Brushless Actuators

## SHA-CG Series

### SHA-CG Series Ratings

Item	Model	SHA32A					SHA40A				
		Gear Ratio		50	80	100	120	160	50	80	100
Maximum Torque <sup>1</sup>	Nm	281	395	433	459	484	523	675	738	802	841
	in-lb	2487	3496	3832	4062	4283	4629	5974	6531	7098	7443
Maximum Rotational Speed	rpm	96	60	48	40	30	80	50	40	33.3	25
Torque Constant	Nm/A(rms)	20	33	41	49	66	25	40	50	60	80
	in-lb/A(rms)	177	292	363	434	584	221	354	443	531	708
Maximum Current <sup>1</sup>	A(rms)	17.7	15.4	13.7	12.2	10	27.2	22	19.6	18	14.7
Moment of Inertia GD <sup>2</sup> /4 (without brake) J	kg•m <sup>2</sup>	1.7	4.3	6.7	9.7	17	4.8	12	19	27	49
	kgf•cm•s <sup>2</sup>	17	44	68	99	175	49	124	194	280	497
Moment of Inertia GD <sup>2</sup> /4 (with brake) J	kg•m <sup>2</sup>	2	5.1	7.9	11	20	5.8	15	23	33	59
	kgf•cm•s <sup>2</sup>	20	52	81	116	207	59	150	235	338	601
One-Way Positioning Accuracy	arc•sec	40	30	30	30	30	40	30	30	30	30
Allowable Moment Load	Nm	580					849				
	in-lb	5133					7514				
Moment Stiffness	Nm/rad	100×10 <sup>4</sup>					179×10 <sup>4</sup>				
	in-lb/rad	29.6					53.2				
Output Resolution	Pulses/Revolution	6,553,600	10,485,760	13,107,200	15,728,640	20,971,520	6,553,600	10,485,760	13,107,200	15,728,640	20,971,520
Power Supply	V	200V					200V				
Mass (without brake)	kg	7.7					13				
Mass (with brake)	kg	8					13.8				
Protection Structure		Enclosed, self-cooled (IP54)									
Environmental Conditions		Operating temperature: 0 to 40°C • Storage temperature: -20 to +60°C. Operating and storage humidity: 20 to 80% RH (No condensation permitted). Vibration resistance : 25m/s <sup>2</sup> (frequency: 10 to 400Hz) • Shock resistance: 300m/s <sup>2</sup> . Indoor installation: No dust, no metal powder, no corrosive gas, no inflammable gas, no oil mist, no other foreign matter and no direct sunshine. Altitude 1000m or less. Insulation resistance: 100MΩ or higher (DC 500V). Dielectric strength: AC 1500V/1min. Insulation class: Class E									
Recommended Driver		REL-230-18, REL-230-36, HA-800-6D/E-200					REL-230-36, REL-230-40, HA-800-24D/E-200				
Encoder Type		Magnetic absolute encoder					Magnetic absolute encoder				

The table shows typical output values of actuators.

\*1 Typical characteristics when combined with our drivers.

Units: mm

Size Symbol	SHA20A	SHA25A	SHA32A	SHA40A
øA	117	144	175	225
øB	69	84	110	132
øC	17	27	35	45
D	26	28.5	34	40
E	125.5	127.5	144	170

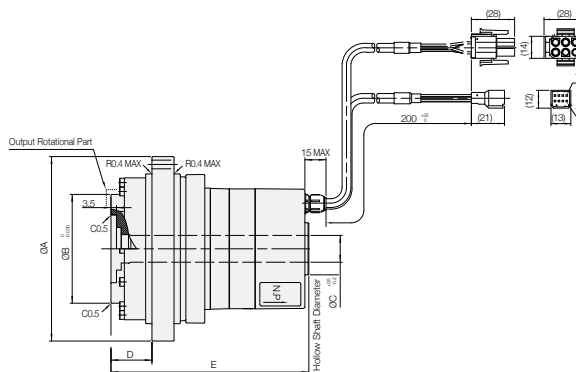

The mechanical accuracies of the output shaft and mounting flange are as follows:

Units: microns

Size Symbol	SHA20A	SHA25A	SHA32A	SHA40A
1. Output shaft surface runout	10	10	10	10
2-1. Output shaft axial runout (Outside diameter)	10	10	10	10
2-2. Output shaft axial runout (Inside diameter)	15	15	15	15
3. Parallelism between the output shaft and actuator mounting surface	30	30	35	35
4. Parallelism between the output shaft and actuator mounting surface	40	40	45	45
5. Concentricity between the output shaft and actuator mounting diameter	50	50	55	60
6. Concentricity between the output shaft and actuator mounting diameter	60	60	65	70

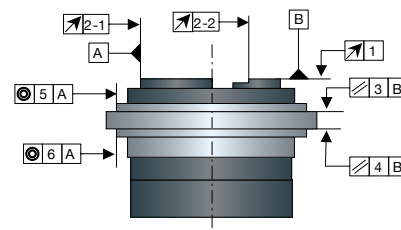

Note: All values are T.I.R. (Total Indicator Reading).

## Hollow Shaft Brushless Actuators

## SHA Series



SHA Series AC Servo Actuators provide high torque and highly accurate rotary operation.

These servo actuators utilize Harmonic Drive® precision gears combined with a brushless servomotor and magnetic absolute encoder. The SHA Series is an advanced version of the FHA series AC Servo Actuators, featuring a larger hollow shaft with a smaller, outside diameter.

The SHA Series is designed to operate with REL Series and HA-800 drivers.

- High torque
- Compact, slim design
- Large center through hole
- Low voltage winding available for SHA25A

## •SHA Series Ratings

Item	Model	SHA20A					SHA25A					SHA32A						
		51	81	101	121	161	11HP	51	81	101	121	161	11HP	51	81	101	121	161
Gear Ratio		51	81	101	121	161	11HP	51	81	101	121	161	11HP	51	81	101	121	161
Maximum Torque <sup>2</sup>	Nm	73	96	107	113	120	26	127	178	204	217	229	62	281	395	433	459	484
	in-lb	646	850	947	1,000	1,062	203	1124	1575	1805	1920	2027	549	2487	3496	3832	4062	4283
Maximum Rotational Speed	rpm	117.6	74.1	59.4	49.6	37.3	509.1	109.8	69.1	55.4	46.3	34.8	436.4	94.1	59.3	47.5	39.7	29.8
Torque Constant	Nm/A(rms)	16.5	27	33	40	53	4.2	19	31	39	46	62	4.5	21	33	42	50	66
	in-lb/A(rms)	146	239	292	354	469	37	168	274	345	407	549	40	186	292	372	443	584
Maximum Current <sup>2</sup>	A(rms)	6.0	4.9	4.5	4.0	3.4	8.9	8.6	7.5	7.0	6.3	5.2	19	17.3	15.2	13.5	12.2	9.9
Moment of Inertia GD <sup>2</sup> /4 (without brake) J	kg•m <sup>2</sup>	0.23	0.58	0.91	1.3	2.3	0.029	0.56	1.42	2.2	3.2	5.6	0.092	2.0	5.1	8.0	11	20
	kgf•cm•s <sup>2</sup>	2.4	6.0	9.3	13	24	0.296	5.7	14.4	22	32	57	0.930	21	52	81	17	207
Moment of Inertia GD <sup>2</sup> /4 (with brake) J	kg•m <sup>2</sup>	0.26	0.65	1.0	1.4	2.6	0.034	0.66	1.66	2.6	3.7	6.6	0.107	2.3	5.9	9.2	13	23
	kgf•cm•s <sup>2</sup>	2.6	6.6	10	15	26	0.347	6.7	17	26	38	67	1.087	24	60	94	135	238
One-Way Positioning Accuracy	arc•sec	60	50	50	50	50	120	50	40	40	40	40	120	50	40	40	40	40
Allowable Moment Load	Nm	187					410	258					932	580				
	in-lb	1,655					3629	2283					8248	5133				
Moment Stiffness	Nm/rad	25.2 x 10 <sup>4</sup>					37.4 x 10 <sup>4</sup>	39.2 x 10 <sup>4</sup>					86.1 x 10 <sup>4</sup>	100 x 10 <sup>4</sup>				
	in-lb/rad	223 x 10 <sup>4</sup>					335 x 10 <sup>4</sup>	346.9 x 10 <sup>4</sup>					761 x 10 <sup>4</sup>	885 x 10 <sup>4</sup>				
Output Resolution	Pulses/Revolution	6,684,672	10,616,832	13,238,272	15,859,712	21,102,592	1,441,792	6,684,672	10,616,832	13,238,272	15,859,712	21,102,592	1,441,792	6,684,672	10,616,832	13,238,272	15,859,712	21,102,592
Power Supply #4	V	AC 200					AC 200	AC 100, AC 200, DC 48V-90V					AC 200	AC 200, DC 48V-90V				
Mass (without brake)	kg	2.0					5	2.95					9.4	5.9				
Mass (with brake)	kg	2.1					5.1	3.1					9.7	6.2				
Protection Structure	Totally enclosed self-cooled type (equivalent to IP54)																	
Environmental Conditions	Operating temperature: 0 to 40°C • Storage temperature: -20 to +60°C. Operating and storage humidity: 20 to 80% RH (No condensation permitted). Vibration resistance : 25m/s <sup>2</sup> (frequency: 10 to 400Hz) • Shock resistance: 300m/s <sup>2</sup> . Indoor installation: No dust, no metal powder, no corrosive gas, no inflammable gas, no oil mist, no other foreign matter and no direct sunshine. Altitude 1000m or less. Insulation resistance: 100MΩ or higher (DC 500V). Dielectric strength: AC 1500V/1min. Insulation class: Class E																	
Recommended Driver DC 48V-90V		-					-	DEP-090-36					-	DEP-090-36				
Recommended Driver AC-100V		-					-	REL-230-18, REL-230-36					-	-				
Recommended Driver AC-200V		REL-230-18, HA-800-3D					REL-230-18	REL-230-18, HA-800-3D					REL-230-18, REL-230-36, HA-800-6D					

1 The table shows typical output values of actuators.

2 When combined with HA-800 driver.

3 Encoder Type: Magnetic absolute encoder. Single Motor Revolution Encoder Resolution: 2<sup>17</sup> (313,072). Motor Multi Revolution Counter: 2<sup>16</sup> (65,536) (Battery back-up).

4 Please refer to the manual for rating details.

## Hollow Shaft Brushless Actuators SHA Series

### SHA Series Ratings

Item		Model		SHA40A					SHA58A				SHA65A			
Gear Ratio		51	81	101	121	161	81	101	121	161	81	101	121	161		
Maximum Torque <sup>2</sup>	Nm	523	675	738	802	841	1924	2067	2236	2392	2400	2990	3263	3419		
	in-lb	4629	5974	6531	7098	7443	17027	18293	19789	21169	21240	26462	28878	30258		
Maximum Rotational Speed		rpm	78.4	49.4	39.6	33.1	24.8	37.0	29.7	24.8	18.6	34.6	27.7	23.1	17.4	
Torque Constant	Nm/A(rms)	25	41	51	61	81	54	68	81	108	54	68	81	108		
	in-lb/A(rms)	221	363	451	540	717	478	602	717	956	478	602	717	956		
Maximum Current <sup>2</sup>		A(rms)	26.7	21.8	19.4	17.9	14.6	45	39	36	30	55	55	51	41	
Moment of Inertia GD <sup>2</sup> /4 (without brake) J	kg•m <sup>2</sup>	5.0	13	20	28	50	96	149	214	379	110	171	245	433		
	kgf•cm•s <sup>2</sup>	51	130	202	290	513	980	1520	2180	3870	1120	1740	2500	4420		
Moment of Inertia GD <sup>2</sup> /4 (with brake) J	kg•m <sup>2</sup>	6.1	15	24	34	61	106	165	237	420	120	187	268	475		
	kgf•cm•s <sup>2</sup>	62	157	244	350	619	1090	1690	2420	4290	130	1910	2740	4850		
One-Way Positioning Accuracy		arc•sec	50	40	40	40	40	40	40	40	40	40	40	40	40	
Allowable Moment Load	Nm	849					2,180				2,740					
	in-lb	7514					19293				24249					
Moment Stiffness	Nm/rad	179 x 10 <sup>4</sup>					531 x 10 <sup>4</sup>				741 x 10 <sup>4</sup>					
	in-lb/rad	1584.2 x 10 <sup>4</sup>					4699.4 x 10 <sup>4</sup>				6557.9 x 10 <sup>4</sup>					
Output Resolution		Pulses/Revolution	6,684,672	10,616,832	13,238,272	15,859,712	21,102,592	10,616,832	13,238,272	15,859,712	21,102,592	10,616,832	13,238,272	15,859,712	21,102,592	
Power Supply #4		V	AC 200					AC 200				AC 200				
Mass (without brake)		kg	9.9					29.5				37.5				
Mass (with brake)		kg	10.7					32				40				
Protection Structure		Totally enclosed self-cooled type (equivalent to IP54)														
Environmental Conditions		Operating temperature: 0 to 40°C • Storage temperature: -20 to +60°C. Operating and storage humidity: 20 to 80% RH (No condensation permitted). Vibration resistance : 25m/s <sup>2</sup> (frequency: 10 to 400Hz) • Shock resistance: 300m/s <sup>2</sup> . Indoor installation: No dust, no metal powder, no corrosive gas, no inflammable gas, no oil mist, no other foreign matter and no direct sunshine. Altitude 1000m or less. Insulation resistance: 100MΩ or higher (DC 500V). Dielectric strength: AC 1500V/1 min. Insulation class: Class E														
Recommended Driver AC-200V		REL-230-36, REL-230-40					-				-					
Recommended Driver		HA-800-24D					HA-800-24D				HA-800-24D					

1 The table shows typical output values of actuators.

2 When combined with a HA-800 driver.

3 Encoder Type: Magnetic absolute encoder. Single Motor Revolution Encoder Resolution: 2<sup>17</sup> (313,072). Motor Multi Revolution Counter: 2<sup>16</sup> (65,536) (Battery back-up).

4 Please refer to the manual for detail of ratings.

Units: mm

Size Symbol	SHA20A	SHA25A	SHA32A	SHA40A	SHA58A	SHA65A
øA	94	114	146	175	247	284
øB	70	86	114	140	203	223
øC	17	27	35	45	65	65
D	11.5	15.5	20	26	37	42.5
E	103	109	125	148	213	222

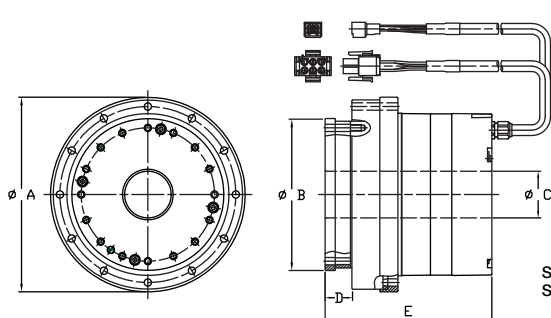

SHA20A, SHA25A, SHA32A,  
SHA40A

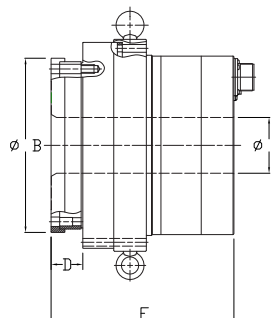

SHA58A, SHA65A

## Brushless Actuators RSF Supermini Series



These extremely small servo actuators utilize zero backlash Harmonic Drive® precision gears, a brushless servo motor and an incremental encoder to deliver precision motion control. The RSF Supermini series is designed to operate with a wide range of third party drivers as well as Harmonic Drive LLC's DCJ Series, DDP Series, DEP Series, and HA680 drivers. The units are small enough to fit inside the finger of a robotic hand.

- Compact, lightweight
- High output torque
- High positional accuracy
- RSF-5B is available with an optional brake

### •RSF Supermini Series Ratings

Item		Model	RSF-3C			RSF-5B			
			30	50	100	30	50	100	
Gear Ratio			30	50	100	30	50	100	
Power Supply Voltage (driver)		V	DC24±10%			DC24±10%			
Maximum Continuous Current		A(rms)	0.65	0.66	0.56	1.11	0.92	0.76	
Rated Torque (during operation at allowable)		Nm	0.03	0.07	0.11	0.18	0.29	0.44	
		in-lb	0.27	0.62	0.97	1.6	2.6	3.9	
Maximum Rotational Speed (output shaft)		rpm	150	90	45	150	90	45	
Continuous Stall Torque		Nm	0.04	0.08	0.12	0.28	0.44	0.65	
		in-lb	0.35	0.71	1.06	2.5	3.9	5.8	
Maximum Instantaneous Current		A(rms)	1.5	1.4	1.1	2.3	2.2	1.7	
Maximum Torque		Nm	0.13	0.21	0.3	0.5	0.9	1.4	
		in-lb	1.15	1.86	2.66	4.4	8	12.4	
Maximum Speed		rpm	333	200	100	333	200	100	
Torque Constant		Nm/A(rms)	0.11	0.18	0.4	0.3	0.54	1.1	
		in-lb/A (rms)	0.97	1.59	3.54	2.66	4.78	9.74	
EMF Constant		V/(rpm)	0.015	0.025	0.05	0.04	0.07	0.13	
Phase Resistance (at 20°C)		Ω	1.34			0.82			
Phase Inductance		mH	0.18			0.27			
Moment of Inertia <sup>4</sup>		GD <sup>2</sup> /4	kg•m <sup>2</sup>	0.11x10 <sup>-4</sup>	0.29x10 <sup>-4</sup>	1.17x10 <sup>-4</sup>	0.66x10 <sup>-4</sup> (0.11x10 <sup>-3</sup> )	1.83x10 <sup>-4</sup> (0.31x10 <sup>-3</sup> )	7.31x10 <sup>-4</sup> (1.23x10 <sup>-3</sup> )
		J	kgf•cm•s <sup>2</sup>	1.07x10 <sup>-4</sup>	2.98x10 <sup>-4</sup>	11.90x10 <sup>-4</sup>	0.67x10 <sup>-3</sup> (1.13x10 <sup>-3</sup> )	1.87x10 <sup>-3</sup> (3.15x10 <sup>-3</sup> )	7.45x10 <sup>-3</sup> (12.6x10 <sup>-3</sup> )
One-Way Positioning Accuracy		arc/sec	600	600	600	240	180	180	
Allowable Radial Load (output shaft central value)		N	36			90			
		lbf	8			20			
Allowable Axial Load		N	130			270			
		lbf	29			61			
Encoder Pulses (motor shaft)		Pulse	200			500			
Quad Encoder Resolution (output shaft: when multiplied by 4) <sup>5</sup>		Pulse/rev.	24,000	40,000	80,000	60,000	100,000	200,000	
Motor Shaft Brake		Input Power Voltage	V	-			DC24±10%		
		Retention Torque	Nm	-			0.18	0.29	0.44
			in-lb	-			0.16	0.26	0.39
Mass <sup>6</sup>		Without Brake	g	31.0(except clamp filter)			66.0(except clamp filter)		
		With Brake	g	-			86.0(except clamp filter)		
Recommended Driver		DC24V	DCJ-055-09/DDP-090-09/DEP-090-09			HA-680-4B-24			
			HA-680-4B-24			HA-680-4B-24			

**Notes:**

- The table shows typical output values of actuators.
- The values in the table above are obtained when it is combined with the driver (HA-680-4B-24).
- All values are typical.
- The moment of inertia is the total value of the motor shaft and the gear's moment of inertia values converted to the output side. The values in parentheses are for equipment with a brake.
- The quad encoder resolution is (motor shaft encoder resolution when multiplied by 4) x (gear ratio).
- The weight of clamp filter is 6g each.

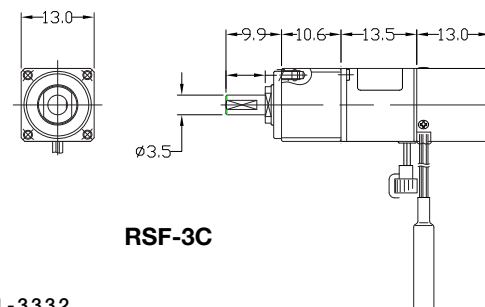
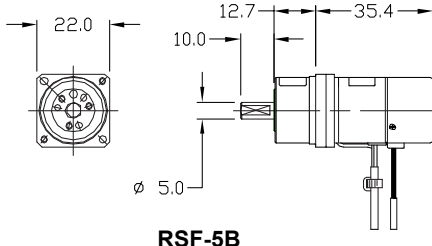



# Brushless Actuators RSF-Mini Series

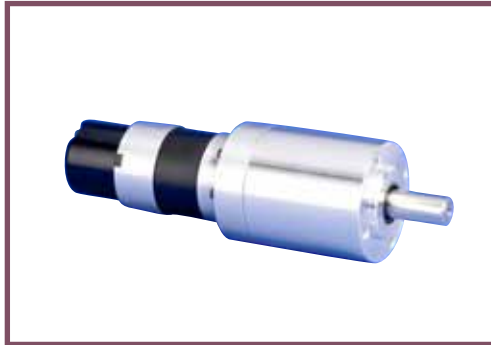

These brushless servo actuators utilize zero backlash Harmonic Drive® precision gears for precise motion control. The RSF Mini Series is designed to operate with a wide range of third party drivers as well as Harmonic Drive LLC's DCJ Series, DDP Series, DEP Series, and HA680 drivers.

- Exceptional positional accuracy
- Compact design

## •RSF Mini Series Ratings

Item		Model	RSF-8B			RSF-11B			RSF-14B		
Gear Ratio			30	50	100	30	50	100	30	50	100
Power Supply Voltage		V	DC24								
Maximum Torque <sup>3</sup>	Nm		1.8	3.3	4.8	4.5	8.3	11	9	18	28
	in-lb		15.9	29.2	42.5	39.8	73.5	97.4	79.7	159	248
Maximum Speed <sup>3</sup>		rpm	200	120	60	200	120	60	200	120	60
Maximum Current <sup>3</sup>		A(rms)	3.8	3.9	2.9	14.4	15.8	9.4	14.4	17.2	12.3
Allowable Continuous Torque <sup>3,4</sup>	Nm		0.78	1.4	2.0	1.1	2.0	4.0	1.7	3.0	6.0
	in-lb		6.9	12.4	17.7	9.7	17.7	35.4	15.0	26.6	53.1
Allowable Continuous Current <sup>3,4</sup>		A(rms)	2.0	2.0	1.5	5.0	4.9	4.9	4.9	4.7	4.7
Allowable Continuous Speed <sup>3</sup>		rpm	100	60	30	100	60	30	100	60	30
Torque Constant		Nm/A (rms)	0.62	1.1	2.1	0.4	0.66	1.5	0.76	1.3	2.6
EMF Constant		V(rpm)	0.07	0.11	0.22	0.04	0.07	0.15	0.08	0.13	0.28
Phase Resistance		Ω (25°C)	0.93			0.19			0.23		
Phase Inductance		mH	0.45			0.1			0.19		
Moment of Inertia	GD <sup>2</sup> /4	×10 <sup>-2</sup> k•gm <sup>2</sup>	0.06	0.16	0.65	0.18	0.49	2.0	0.41	1.1	4.5
	J	×10 <sup>-2</sup> kgf•cm•s <sup>2</sup>	0.6	1.7	6.6	1.8	5.0	20	4.1	11	46
Allowable Radial Load		N	196			245			392		
		lbf	44			55			88		
Allowable Axial Load		N	98			196			392		
		lbf	22			44			88		
One-Way Positioning Accuracy		arc/sec	180	150	150	150	120	120	150	120	120
Quad Encoder Resolution <sup>6</sup>		p/rev	120000	200000	400000	120000	200000	400000	120000	200000	400000
Mass		kg	0.3			0.5			0.8		
Insulation Class			B								
Insulation Resistance			100M Ω (DC500V) or more								
Withstanding Voltage			AC500V/1 min								
Recommended Driver		DC24V	DCJ-055-09/DDP-090-09/ DEP-090-09/HA-680-4B-24			DDP-090-36/DEP-090-36/HA-680-6B-24					

### Notes:

- 1 The table shows output values of the actuator.
- 2 All specifications are applicable for actuators mounted on an aluminum heat sink of size: 150 x 150 x 6(mm).
- 3 Values for saturated actuator temperature. Other values are for actuator temperature of 20°C.
- 4 Values are during operation at allowable continuous rotation speed.
- 5 All values are typical.
- 6 Quad encoder resolution is (motor shaft encoder resolution) x 4 x (gear ratio).
- 7 The specifications above are based on using HA-680 driver.

Model	A	B	C	D	ø Eh7	ø F	G
RSF-8B	124.3	21.8	76.5	26	21	34.5	7.5
RSF-11B	141.7	25	90.7	26	24	32.5	9.5
RSF-14B	168.5	28	114.5	26	30	32.5	11.5

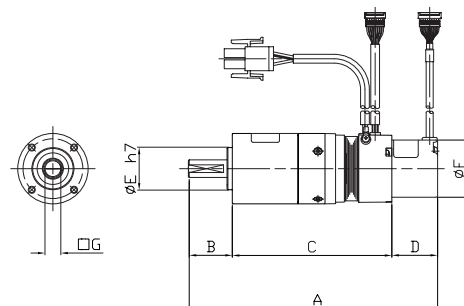

# Brushless Actuators RSF Series



The RSF series is compact and includes high torque AC servo actuators with high rotational accuracy, a shaft output combining Harmonic Drive® strain wave gearing for precision control and an AC servomotor. The RSF Series is designed to operate with a wide range of third party drivers as well as Harmonic Drive LLC's RTL Series, and REL Series.

- Compact and lightweight
- High power
- High positioning and high rotational accuracies

## •RSF Series Ratings

Item	Model	RSF-17		RSF-20A		RSF-25A		RSF-32A	
		50	100	50	100	50	100	50	100
Gear Ratio		50	100	50	100	50	100	50	100
Rated Output	W	62	62	120	111	180	190	310	310
Power Supply Voltage (driver)	V	AC200V							
Rated Torque	Nm	9.8	20	19	35	29	59	49	98
	in-lb	87	177	168	310	257	522	434	867
Rated Rotational Speed	rpm	60	30	60	30	60	30	60	30
Continuous Stall Torque	Nm	9.8	20	19	35	29	59	49	98
	in-lb	87	177	168	310	257	522	434	867
Max. Momentary Torque	Nm	34	54	56	82	98	157	220	330
	in-lb	301	478	496	726	867	1389	1947	2921
Max. Rotational Speed	rpm	90	45	90	45	90	45	90	45
Moment of Inertia <sup>4</sup>	(GD <sup>2</sup> /4) kg.m <sup>2</sup>	0.047	0.19	0.098	0.39	0.19	0.77	0.67	2.7
	(J) kgfcm <sup>2</sup>	0.48	1.9	1.0	4.0	2.0	7.9	6.9	27
One-Way Positioning Accuracy	arc/sec	120		90		90		90	
Allowable Radial Load	N	780		1400		2900		4400	
	Lbf	175		315		652		989	
Allowable Axial Load	N	780		1370		2900		4400	
	Lbf	175		308		652		989	
Quad Encoder Resolution <sup>5</sup>	Pulses/Revolution	400,000	800,000	400,000	800,000	400,000	800,000	400,000	800,000
Mass	kg	2.1		2.9		4.7		8.7	
Recommended Driver	AC200	RTL-230-18, REL-230-18							

**Notes:**

- The aforementioned values are those at the output shaft.
- The actuator specification is the value when mounted on the following aluminum radiation plate:  
 RSF-17, RSF-20 250 x 250 x 12mm  
 RSF-25, RSF-32 300 x 300 x 15mm
- The values are those on temperature rise saturation. The other values are those at 20°C.
- The moment of inertia is the sum of the inertia of the motor and Harmonic Drive® gear reflected at the output shaft.
- Quad Encoder resolution is calculated using (Motor shaft encoder resolution) x 4 x (Reduction ratio).

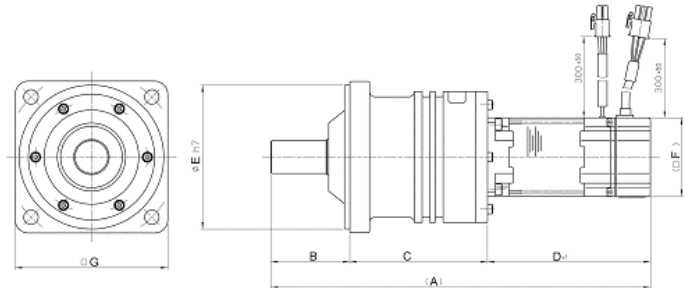

Unit: mm

Model	A	B	C	D±1	ø Eh7	F	G	Mass(kg)
RSF-17A	210	40	88	82	20	60	76	2.1
RSF-20A	242	48	98	96	85	60	93	2.9
RSF-25A	288.7	60	104.7	124	110	60	116	4.7
RSF-32A	331	80	123	128	130	80	137	8.7

# Brushless Actuators RKF Series

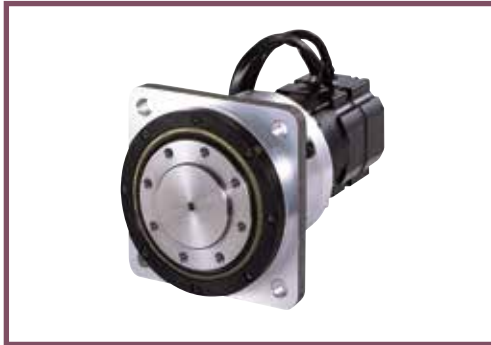

The RKF series is compact and includes high torque AC servo actuators with high rotational accuracy, a flange output combining Harmonic Drive® strain wave gearing for precision control and an AC servo motor. The RKF Series is designed to operate with a wide range of third party drivers as well as Harmonic Drive LLC's RTL Series, and REL Series.

- Compact and lightweight
- High power
- High positioning and high rotational accuracies

## •RKF Series Ratings

Item		Model	RKF-20A		RKF-25A		RKF-32A	
Gear Ratio			50	100	50	100	50	100
Rated Output		W	120	111	180	190	310	310
Power Supply Voltage (driver)		V	AC200					
Rated Torque		Nm	19	35	29	59	49	98
		in-lb	168	310	257	522	434	867
Rated Rotational Speed		rpm	60	30	60	30	60	30
Continuous Stall Torque		Nm	19	35	29	59	49	98
		in-lb	168	310	257	522	434	867
Max. Momentary Torque		Nm	56	82	98	157	220	330
		in-lb	496	726	867	1389	1947	2921
Max. Rotational Speed		rpm	90	45	90	45	90	45
Moment of Inertia		(GD <sup>2</sup> /4) kg.m <sup>2</sup>	0.098	0.39	0.19	0.77	0.67	2.7
		(J) kgfcm <sup>2</sup>	1.0	4.0	2.0	7.9	6.9	27
One-Way Positioning Accuracy		arc/sec	90		90		90	
Allowable Radial Load		N	2000		2500		3900	
		Lbf	450		562		877	
Allowable Axial Load		N	880		1100		1600	
		Lbf	198		247		360	
Quad Encoder Resolution <sup>5</sup>		Pulses/ Revolution	400,000	800,000	400,000	800,000	400,000	800,000
Mass		kg	2.9		5.0		9.5	
Recommended Driver		AC200	RTL-230-18, REL-230-18					

**Notes:**

- The aforementioned values are those at the output shaft including the Harmonic Drive® gear efficiency.
- The actuator specifications are based on operating when mounted on an aluminum heat sink of the following sizes or its equivalent:  
 RKF-20                    250 x 250 x 12mm  
 RKF-25, RKF-32        300 x 300 x 15mm
- The values are those on temperature rise saturation. The other values are those at 20°C.
- The moment of inertia is the total of the inertia moments of the motor shaft and Harmonic Drive® gear converted into the output shaft side.
- Quad Encoder resolution is calculated using (Motor shaft encoder resolution) x 4 x (Reduction ratio).

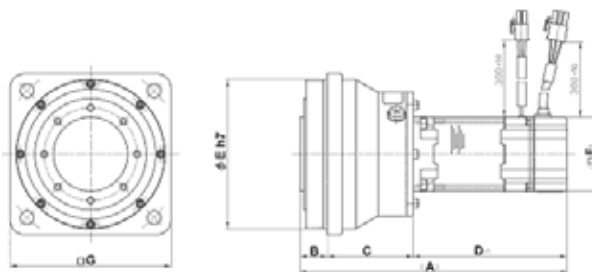

Unit: mm

Model	A	B	C	D±1	ø Eh7	F	G	Mass(kg)
RKF-20A	180	20	64	96	100	60	108	2.9
RKF-25A	215.5	22	69.5	124	120	60	130	5.0
RKF-32A	241	25.5	87.5	128	155	80	165	9.5

## DC Servo Actuators RH Mini Series



This RH Mini Series is a DC servo actuator incorporating Harmonic Drive® precision gears, a high performance brush DC servomotor and an incremental encoder.

- High torque
- Precise positional accuracy
- Compact design

### •RH Series Ratings

Item		Model	RH-5A			RH-8D		RH-11D		RH-14D	
			8802	5502	4402	6006	3006	6001	3001	6002	3002
Rated Output	W		1.5	1.7	1.4	8.6	6.2	13.6	12.3	20.3	18.5
Rated Voltage	V		12	12	12	24	24	24	24	24	24
Maximum Momentary Torque	Nm		0.39	0.59	0.69	2.7	3.5	4.9	7.8	14	20
	in-lb		3.45	5.22	6.11	23.9	31.0	43.4	60.0	123.9	177.0
Maximum Continuous Stall Torque	Nm		0.24	0.39	0.43	1.5	2.3	2.5	4.4	5.4	7.8
	in-lb		2.12	3.45	3.81	13.3	20.4	22.1	38.9	47.8	69.0
Rated Torque	Nm		0.16	0.29	0.29	1.4	2	2.2	3.9	3.2	5.9
	in-lb		1.42	2.57	2.57	12.4	17.7	19.5	34.5	28.3	52.5
Maximum Positioning Speed	rpm		180	110	90	100	50	100	50	100	50
Rated Positioning Speed	rpm		88	55	44	60	30	60	30	60	30
Maximum Momentary Current	A(rms)		0.83	0.78	0.77	1.6	1.1	2.4	2.1	5.4	4.1
Rated Current	A(rms)		0.5	0.5	0.5	1.0	0.8	1.3	1.3	1.8	1.8
Torque Constant	Nm/A(rms)		0.69	1.11	1.38	2.1	4.2	2.46	4.91	2.92	5.76
	in-lb/A(rms)		6.1	9.8	12.2	18.6	37.2	21.7	43.5	25.8	51
Moment of Inertia	kg•m <sup>2</sup>		6.3x10 <sup>-4</sup>	16x10 <sup>-4</sup>	25x10 <sup>-4</sup>	37x10 <sup>-4</sup>	150x10 <sup>-4</sup>	110x10 <sup>-4</sup>	430x10 <sup>-4</sup>	210x10 <sup>-4</sup>	810x10 <sup>-4</sup>
	kgf•cm•s <sup>2</sup>		0.007	0.016	0.026	0.04	0.15	0.11	0.44	0.21	0.83
One-Way Positioning Accuracy	arc/sec		290	290	290	150	150	120	120	120	120
Allowable Axial Load	N		29	29	29	98	98	196	196	392	392
	lbf		7	7	7	22	22	44	44	88	88
Reduction Ratio			50	80	100	50	100	50	100	50	100
Mass	kg		0.09	0.09	0.09	0.3	0.3	0.5	0.5	0.77	0.77
Environmental Conditions	Time constant: Continuous • Protection: Totally closed, self-cooling • Ambient temperature: 0 to 40°C Ambient humidity: 35 to 80% RH (no condensation permitted)										
Recommended Driver	DC 20V		DCJ-055-09, DDP-090-09, DEP-090-09			-	-	-	-	-	-
			-			DCJ-055-09, DDP-090-09, DEP-090-09					

Model	øA	øB	C	D
RH-5A	20	5	11	78
RH-8D	33	8	21.8	107.2
RH-11D	40	10	25	125.5
RH-14D	50	12	28	148

Unit: mm

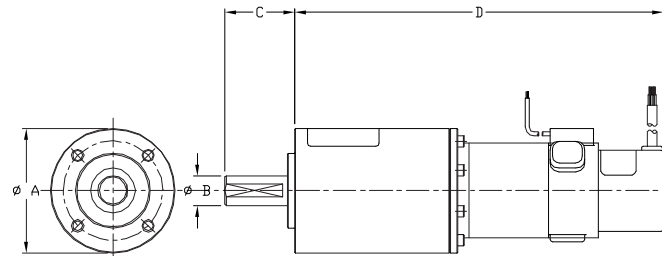



# Direct Drive Motor KDU Series



The KDU Series are Direct Drive Motors which achieve 10 arc-sec positioning accuracy as well as  $\pm 0.5$  arc-sec repeatability with a resolution of 0.16 arc-sec. Also, the KDU has a large Hollow Shaft design which allows cables, shafts or lasers to pass through the axis of rotation.

- Exceptional positional accuracy
- Exceptional repeatability
- Ultra high resolution

## •KDU Series Ratings

Item	Model	KDU-13SB	KDU-13WB
	Maximum Torque <sup>2</sup>	Nm	7.0Nm (62.0 In.lb)
Max. Rotational Speed	rpm	127	127
Torque Constant	Nm/A(rms)	3.1 (26.9 In.lb/A(rms))	6.5 (56.4 In.lb/A(rms))
Input Power Supply Voltage	V	AC 100/AC200	
Moment of Inertia	kg.m <sup>2</sup>	0.0047	0.0065
Moment Stiffness	Nm/rad	2.4 x 10 <sup>5</sup>	
Motor Position Sensor	pulse/rev	Incremental encoder Square wave : phase A and B: 11,840,000 Z Index Pulse Signal	
Repeatability <sup>3</sup>	arc sec	$\pm 0.5$	
Absolute Positioning Accuracy <sup>4</sup>	arc sec	10 (Angular position corrected)	
Mass	kg	4.0	5.0
Mounting Direction	-	Output shaft to face upward	
Combined Driver	-	HA-770-2	
Induced Voltage Constant	V/ (rpm)	.033	0.68
Line Resistance	$\Omega$ (20°C)	9.1	14.0
Line Inductance	mH	19	35
Motor Insulation	-	Insulation Resistance: 100 M $\Omega$ more (DC500V) Insulation Strength: AC1500V/1min. Insulation Class: Class B	
Protective Structure <sup>5</sup>	-	Total-enclosed self-enclosed type (IP 40 or equivalent)	

1 The table above shows output values of output shaft.  
 2 The values in the table above are obtained when connected to HA-770 servo driver.  
 3 The repeatability and absolute repeatability are the values measured in an environment of 23  $\pm$ 0.3°C in temperature, 50% RH in humidity and with output shaft facing upward in mounting direction. Please contact Harmonic Drive LLC, to inquire about use with different environmental conditions.  
 4 Value after angular position of the HA-770 servo driver is corrected.  
 5 All parts, except the rotary sliding parts (oil seal), of the actuators are protected against solid bodies of superior dimensions to 1mm, and against the water sprays.

### •Direct Drive Motor HA-770 Series

Model	HA-770-2
Rated Current	1.8A
Maximum Current	10A
Power Source Voltage	AC100V~115V(Single-phase) + 10%~-15% 50/60Hz, AC200V~230V (Single-phase) + 10%~-15% 50/60Hz
Position Command Pulse	Line driver system: Maximum response frequency, Two-pulse system, One-pulse system: 1MHz, Two-phase pulse system: 200kHz
Control System	Sine wave PWM system, switching frequency: 25kHz
Control Mode	Position control
Weight	0.8kg

### •Motor Length

Unit: mm

	KDU-13SB	KDU-13WB
A	80	94



HA-770 Series

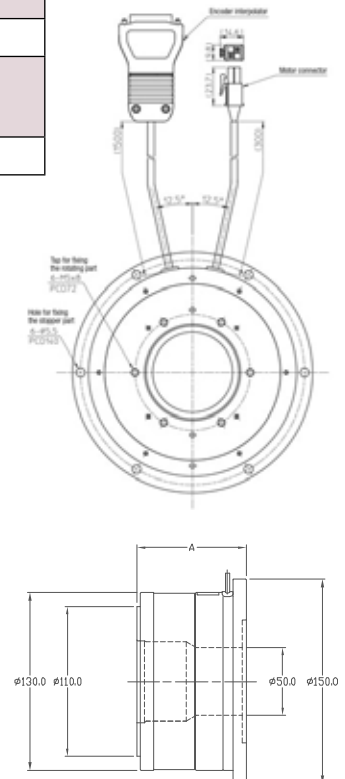

**Hollow Shaft Motor**  
**MA Motor**



Harmonic Drive LLC offers MA hollow shaft motors. Hollow shaft design allows cables, shafts or lasers to pass through the axis of rotation.

- Large Hollow Shaft
- 17-bit Absolute Encoder
- Available in 5 frame sizes

**•MA Motor Ratings**

Item		Model	MAC08A200 MAC08B200* (for SHA20A)	MAB09A200 MAB09B200* (for SHA25A 200V)	MAB09A100 MAB09B100* (for SHA25A 100V)	MAB12A200 MAB12B200* (for SHA32A)	MAB15A200 MAB15B200* (for SHA40A)	MAA21AA200 MAA21AB200* (for SHA58A)
Number of poles	-		10	10	10	10	10	16
Rated torque <sup>1, 2</sup>	Nm		0.52	1	0.88	2.2	4.5 (2.5) <sup>4</sup>	14
Rated rotational speed <sup>1, 2</sup>	rpm		3000	3000	3000	2500	2000	1500
Rated power <sup>1, 2</sup>	W		163	314	276	576	942 (524) <sup>4</sup>	2200
Torque constant <sup>1</sup>	Nm/ A(rms)		0.35	0.41	0.24	0.44	0.54	0.72
Rated current <sup>1, 2</sup>	A(rms)		2.1	3	4.7	6	10 (6) <sup>4</sup>	23
Rated stall current <sup>2</sup>	A		2.4	3.6	6.2	8.5	13 (8.5) <sup>4</sup>	33
Max. torque <sup>1</sup>	Nm		1.8	3	3	7	13 (8.3) <sup>4</sup>	45 (33) <sup>5</sup>
Max. rotational speed <sup>1</sup>	rpm		6000	5600	4800	4800	4000	3000
Max. current <sup>1</sup>	A(rms)		6.5	8.9	15.4	19	29 (19) <sup>4</sup>	75 (55) <sup>5</sup>
EMF constant <sup>3</sup>	V/ (rpm)		0.037	0.043	0.025	0.046	0.057	0.075
Phase resistance (at 20°C)	Ω		1.43	1.2	0.4	0.33	0.19	0.028
Phase inductance	mH		2.5	3	1	1.4	1.2	0.29
Moment of Inertia (without brake)	kg·m <sup>2</sup>		0.69 x10 <sup>-4</sup>	1.4 x10 <sup>-4</sup>	1.4 x10 <sup>-4</sup>	4.8 x10 <sup>-4</sup>	13 x10 <sup>-4</sup>	115 x10 <sup>-4</sup>
Moment of Inertia (with brake)	kg·m <sup>2</sup>		0.78 x10 <sup>-4</sup>	1.8 x10 <sup>-4</sup>	1.8 x10 <sup>-4</sup>	6.0 x10 <sup>-4</sup>	17 x10 <sup>-4</sup>	131 x10 <sup>-4</sup>
Mass (without brake)	kg		1.1	1.5	1.5	2.8	4.4	14.8
Mass (with brake)	kg		1.2	1.65	1.65	3.2	5.2	17.1
Power Supply Voltage	V		AC200	AC200	AC100	AC200	AC200	AC200
Encoder type	-	Absolute encoder						
Single motor revolution Encoder resolution	-	2 <sup>17</sup> (131072)						
Motor multi revolution counter	-	2 <sup>16</sup> (65536)						
Motor insulation	-	Insulation resistance : 100MΩ MIN (DC 500V) Dielectric strength : AC1500V/1min Insulation class : A						

\* B indicates with brake

\*1 The table shows typical output values

\*2 Value after temperature rise and saturation when it is used with aluminum radiation plate shown below:

MAC08□320x320x16[mm], MAB09□350x350x18[mm], MAB12□400x400x20[mm], MAB15□500x500x25[mm], MAA21A□650x650x30[mm]

\*3 Value shown is for one Phase. Multiply by 3 for phase-to-phase value.

\*4 When combined with our driver (HA-800-6)

\*5 When combined with our driver (HA-800-24)

**Precision Linear Actuators**  
**LBC Series**



The precision lead screw provides positioning accuracy in the micron range with sub-micron repeatability. The actuator is capable of thrust forces up to 12,000 N.

This product is useful for precise positioning of heavy loads or applications where high force is required such as molding equipment or precision presses.

- 12,000 N Force
- 0.32  $\mu\text{m}$  positioning resolution
- Brushless servomotor with incremental encoder
- Integral Limit Switches

**•LBC Series Ratings**

Model	Item	Drive	Stroke (mm)	Maximum Driving Force (N)	Resolution ( $\mu\text{m}$ )	Maximum Speed (mm/s)	Repeatability	Outside Dimensions (mm)	Total length (mm)
LBC-25A-5D6K		Brushless Motor	50	6000	0.32	20	$\pm 5\mu\text{m}$ or less/50mm stroke	$\phi 136$	353
LBC-25A-5D12K		Brushless Motor	50	12000	0.16	10			

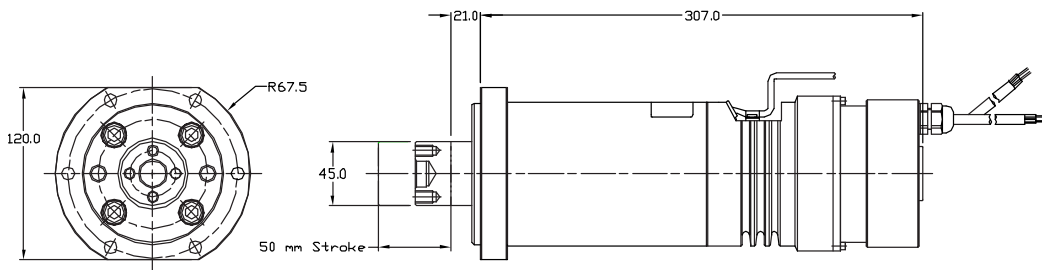

Precision Linear Actuators

# LA Series



A precision ball screw provides positioning accuracy better than 2 microns and repeatability of 0.1 microns.

This product is well suited for measuring instruments, test and inspection systems, optical equipment, semiconductor and LCD manufacturing equipment.

- 49 N Force
- 2 micron positioning accuracy
- Brush DC motor with incremental encoder

## •LA Series Ratings

Item Model	Drive	Stroke (mm)	Maximum Driving Force (N)	Resolution ( $\mu\text{m}$ )	Maximum Speed (mm/s)	One-way Positioning Accuracy	Repeatability	Outside Dimensions (mm)	Total length (mm)
LA-30B-10-F	DC motor	10	49	0.0174	0.9	2 $\mu\text{m}$ or less/40 $\mu\text{m}$ stroke	$\pm 0.1\mu\text{m}$ or less/1mm stroke	28	143
LA-32-30-F	DC motor	30	49	0.0174	0.9			36	164

Unit: mm

Size	LA-30B-10F	LA-32-30-F
A	28	36
B(Stroke)	10	30
C	10	13.3
D	133	150.8

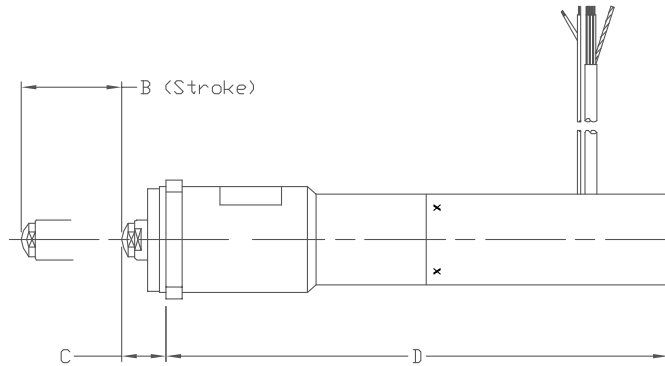
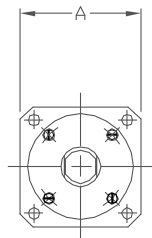



# LAH Series



A precision ball screw provides positioning accuracy better than 4 microns and repeatability of 1 micron.

This product is well suited for measuring instruments, test and inspection systems, optical equipment, semiconductor and LCD manufacturing equipment.

- 392 to 3000 N Force
- 4 micron positioning accuracy

## •LAH Series Ratings

Model	Item	Drive	Stroke (mm)	Maximum Driving Force (N)	Resolution (μm)	Maximum Speed (mm/s)	One-way Positioning Accuracy	Repeatability	Outside Dimensions (mm)	Total length (mm)
LAH-46-1002-F		DC motor	10	392	0.069	3.7	4μm or less/.02mm stroke	±0.5μm or less/1mm stroke	47	185
LAH-46-3002-F		DC motor	30	392	0.069	3.7			47	204
LAH-80-5020-F-PA		Stepping motor	50	3000	2	10	4μm or less/2mm stroke	±1μm or less/1mm stroke	85	320

Unit: mm

Model	LAH-46-1002-F	LAH-46-3002-F
Symbol		
A	47	47
B(Stroke)	10	30
C	16	16
D	169	188

LAH-46

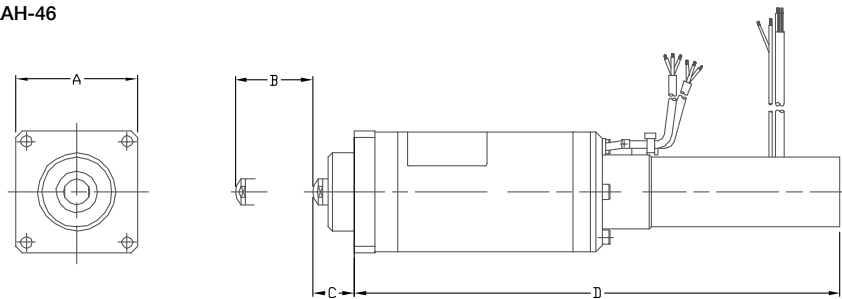

LAH-80

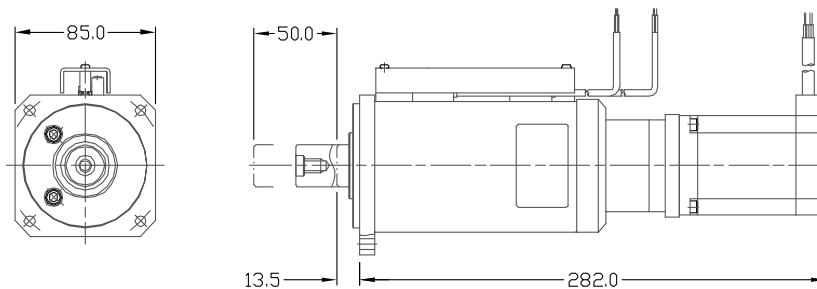

## Galvano Optical Scanners LSA Series



Galvanometric Laser Scanning Actuator. LSA laser scanning actuators are Galvanometric scanners capable of scanning at high speed with high precision. A newly developed optical sensor and our unique moving magnet motors are used in the LSA Series laser scanning actuators

- High response frequency
- High accuracy / repeatability
- Continuous scanning or discrete pointing

### •LSA Series Ratings

Model		Item	LSA-10A-30
Maximum Angular Runout		Degrees	±15
Rotor Moment of Inertia		$\text{g}\cdot\text{cm}^2$	1.9
Torque Constant		$\text{Nm}/\text{A}(\text{rms})$	0.008
Coil Resistance		$\Omega$	0.28
Coil Inductance		mH	0.098
Sensor Linearity (At full scale)		%	±0.06
Sensor Angle Sensitivity		$\text{V}/^\circ$	0.275
Offset Drift		$\mu\text{rad}/^\circ\text{C}$	25
Scale Drift		$\%/^\circ\text{C}$	0.005
Repeatability (Excluding offset/scale drift) <sup>1</sup>		mrad	±5
1°step Response Load Condition: $(2\text{g}\cdot\text{cm}^2)^2$		ms	0.5
Sensor Power Supply		V	5±5%-15±5%
Sensor Power Consumption	5V±5%	mA	90(Max)
	-15V±5%	mA	120(Max)
Weight		g	180

<sup>1</sup> All angles are mechanical angles.

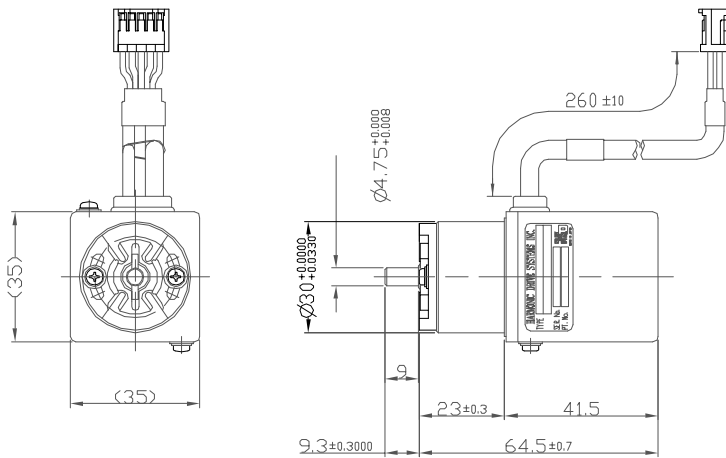

LSA-10A-30

# Micro Encoder Series

	<p>Available in two sizes, the micro encoders are ultra-miniature, high resolution incremental encoders.</p> <p>The ultra-micro model</p> <ul style="list-style-type: none"> <li>Dimensions <math>\phi 7.5 \times 10.5\text{mm}</math>, Incremental encoder 360 line count</li> <li>Output phases: A, B, Z</li> <li>Square wave open collector output</li> </ul> <p>The micro model</p> <ul style="list-style-type: none"> <li>Dimensions <math>\phi 13 \times 20\text{mm}</math>, Incremental encoder 1000 line count</li> <li>Output phases: A, B, Z</li> <li>Square wave open collector output</li> <li>Hollow shaft is also available</li> </ul>
---	--

## •Micro Encoder Series Ratings

Item	Model	MES-6- <input type="checkbox"/> PC	ME <input type="checkbox"/> -9- <input type="checkbox"/> PC
		Number of Pulses	Shaft Shape *S: Single Shaft *H: Hollow Shaft
Power Supply		DC5V $\pm$ 10%	DC5V $\pm$ 10%
Current Consumption		30mA or less (under no load)	40mA or less (under no load)
Detection System		Incremental	Incremental
Number of Output Pulses (Standard) [Number of Pulses/Number of Revolutions]		100 200 300 360	100 200 300 360 500 1000
Output Phases		A, B and Z phases	A, B and Z phases
Output Mode		Square wave, open collector output	Square wave, open collector output
Maximum Response Frequency (Number of Response Pulses)		100kHz	100kHz
Output Phase Difference		Difference between A and B Phases $90^\circ \pm 45^\circ$ ( $T/4 \pm T/8$ ), Z Phase $T \pm T/2$ (See output waveform diagram.)	Difference between A and B Phases $90^\circ \pm 45^\circ$ ( $T/4 \pm T/8$ ), Z Phase $T \pm T/2$ (See output waveform diagram.)
Permissible Maximum Positioning Speed (Mechanical)		6000rpm	6000rpm
Operating Temperature and Humidity		0°C-60°C RH 35%-90% No condensation permitted	0°C-60°C RH 35%-90% No condensation permitted
Storage Ambient Temperature		-20°C-80°C	-20°C-80°C
Weight		5g	10g

## •Model Ordering Code

ME- X- X- XXXPX  
1 2 3 4

- 1 Shaft shape : S, H\*\*
- 2 Size : 6, 9
- 3 Output pulses : 100, 200, 300, 360, 500\*\*, 1000\*\*
- 4 Output circuit : C = Open collector output  
None = Voltage output \*\*\*

\*\* Hollow shaft feature and line counts of 500 and 1000 are only available in size 9  
\*\*\* Voltage output is only available in size 9.

### 06 SERIES

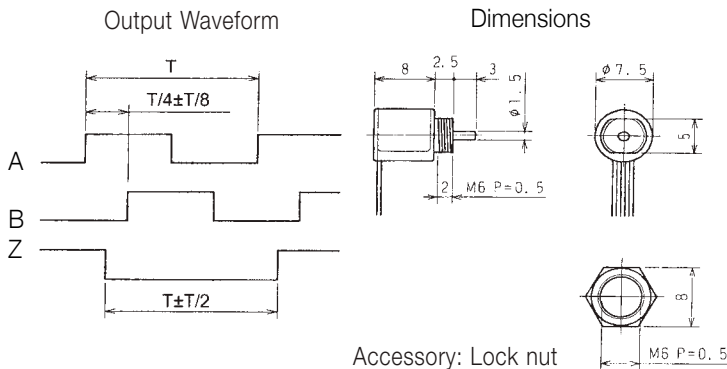

\* Z is Low-active

### 09 SERIES

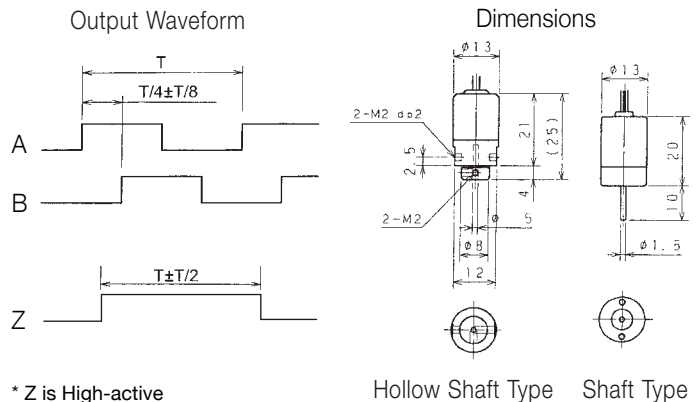

\* Z is High-active

Hollow Shaft Type Shaft Type

# Servo Drivers



## • Servo Driver Specifications

### • DC Digital Servo Drive DCJ Series

MODEL	Vdc	Ic (Apk)	Ip (Apk)	Control Modes	Control Interface	Encoder
DCJ-055-09	20-55	3	9	Indexer, Point-to-Point, PVT Camming, Gearing, Position, Velocity, Torque	CANopen/DeviceNet ASCII and discrete I/O, Stepper commands ± 10V position/velocity/torque command PWM velocity/torque command Master encoder (Gearing/Camming)	14 Wire Standard Incremental Encoder Type
DCJ-055-18	20-55	6	18			
DCJ-090-03	20-90	1	3			
DCJ-090-09	20-90	3	9			
DCJ-090-12	20-91	6	12			



### • DC Digital Servo Drive DDP Series

MODEL	Vdc	Ic (Apk)	Ip (Apk)	Control Modes	Control Interface	Encoder
DDP-090-09	90	3	9	Indexer, Point-to-Point, PVT Camming, Gearing, Position, Velocity, Torque	CANopen/DeviceNet ASCII and discrete I/O, Stepper commands ± 10V position/velocity/torque command PWM velocity/torque command Master encoder (Gearing/Camming)	14 Wire Standard Incremental Encoder Type
DDP-090-18	90	6	18			
DDP-090-36	90	12	36			
DDP-055-18	55	6	18			
DDP-180-09	180	3	9			
DDP-180-18	180	6	18			



### • DC Digital Servo Drive DEP Series

MODEL	Vdc	Ic (Apk)	Ip (Apk)	Control Modes	Control Interface	Encoder
DEP-090-09	90	3	9	Indexer, Point-to-Point, PVT Camming, Gearing, Position, Velocity, Torque	CANopen over EtherCAT (CoE) ASCII and discrete I/O ± 10V position/velocity/torque command Master encoder (Gearing/Camming)	14 Wire Standard Incremental Encoder Type EnDat 2.1/2.2 4 Wire Serial Communication Incremental Encoder HD Absolute Encoder A Type Biss-C (multi-turn, Bi-direction)
DEP-090-18	90	6	18			
DEP-090-36	90	12	36			
DEP-055-18	55	6	18			
DEP-180-09	180	3	9			
DEP-180-18	180	6	18			
DEP-090-09	90	3	9			
DEP-090-18	90	6	18			
DEP-090-36	90	12	36			
DEP-090-09	90	3	9			
DEP-090-18	90	6	18			
DEP-090-36	90	12	36			



### • AC Digital Servo Drive RTL Series

MODEL	Vac	Ic (Apk)	Ip (Apk)	Control Modes	Control Interface	Encoder
RTL-230-18	100-240	6	18	Indexer, Point-to-Point, PVT Camming, Gearing, Position, Velocity, Torque	CANopen/DeviceNet ASCII and discrete I/O, Stepper commands ± 10V position/velocity/torque command PWM velocity/torque command Master encoder (Gearing/Camming)	14 Wire Standard Incremental Encoder Type
RTL-230-36	100-240	12	36			
RTL-230-40	100-240	20	40			



### • AC Digital Servo Drive REL Series

MODEL	Vac	Ic (Apk)	Ip (Apk)	Control Modes	Control Interface	Encoder
REL-230-18	100-240	6	18	Indexer, Point-to-Point, PVT Camming, Gearing, Position, Velocity, Torque	CANopen over EtherCAT (CoE) ASCII and discrete I/O, Stepper commands ± 10V position/velocity/torque command PWM velocity/torque command Master encoder (Gearing/Camming)	14 Wire Standard Incremental Encoder Type 4 Wire Serial Communication Incremental Encoder HD Absolute Encoder S Type HD Absolute Encoder A Type Biss-C (multi-turn, Bi-direction) EnDat 2.1/2.2
REL-230-36	100-240	12	36			
REL-230-18	100-240	6	18			
REL-230-36	100-240	12	36			
REL-230-18	100-240	6	18			
REL-230-36	100-240	12	36			
REL-230-18	100-240	6	18			
REL-230-36	100-240	12	36			
REL-230-18	100-240	6	18			
REL-230-40	100-240	20	40			



# Recommended Driver

## •Combinations with Servo Drive and Actuator

### •DC Digital Servo Drive DCJ Series

MODEL	Vdc	Ic (Apk)	Ip (Apk)	Supply Voltage	Combination Actuator
DCJ-055-09	20-55	3	9	DC24V	FHA-8C-30 / 50 / 100-US200-E, RSF-8B-30 / 50 / 100-F100-24B, RSF-5A-30 / 50 / 100-US050, RSF-3B-30 / 50 / 100-US020
DCJ-055-18	20-55	6	18		FHA-11C-30 / 50 / 100-US200-E
DCJ-090-03	20-90	1	3		-
DCJ-090-09	20-90	3	9		-
DCJ-090-12	20-90	6	12		-

### •DC Digital Servo Drive DDP Series

MODEL	Vdc	Ic (Apk)	Ip (Apk)	Supply Voltage	Combination Actuator
DDP-090-09	90	3	9	DC24V	FHA-8C-30 / 50 / 100-US200-E, RSF-8B-30 / 50 / 100-F100-24B, RSF-5A-30 / 50 / 100-US050, RSF-3B-30 / 50 / 100-US020
DDP-090-18	90	6	18		FHA-11C-30 / 50 / 100-US200-E
DDP-090-36	90	12	36		FHA-14C-30 / 50 / 100-US200-E, FHA-17C50* / 100 / 160-US250-E-SP, RSF-14B-30 / 50 / 100-F100-24B, RSF-11B-30 / 50 / 100-F100-24B
DDP-055-18	55	6	18		-
DDP-180-09	180	3	9		-
DDP-180-18	180	6	18		-

### •DC Digital Servo Drive DEP Series

MODEL	Vdc	Ic (Apk)	Ip (Apk)	Supply Voltage	Combination Actuator
DEP-090-09	90	3	9	DC24V	FHA-8C-30 / 50 / 100-US200 / 12S176b / E200, RSF-8B-30 / 50 / 100-F100-24B, RSF-5A-30 / 50 / 100-US050, RSF-3B-30 / 50 / 100-US020
DEP-090-18	90	6	18		FHA-11C-30 / 50 / 100-US200 / 12S176b / E200
DEP-090-36	90	12	36		FHA-14C-30 / 50 / 100-US200 / 12S176b / E200, FHA-17C50* / 100* / 160-US250 / E250 / S248, RSF-14B-30 / 50 / 100-F100-24B, RSF-11B-30 / 50 / 100-F100-24B

### •AC Digital Servo Drive RTL Series

MODEL	Vac	Ic (Apk)	Ip (Apk)	Supply Voltage	Combination Actuator
RTL-230-18	100-240	6	18	AC100/200V	FHA-8C-30 / 50 / 100-US200 / 12S176b / E200, FHA-11C-30 / 50 / 100-US200 / 12S176b / E200, FHA-14C-30 / 50 / 100-US200 / 12S176b / E200
				AC100V	FHA-17C-50 / 100 / 160-US250 / E250 / S248, FHA-25C-100 / 160-US250 / E250 / S248, FHA-32C-160-US250 / E250 / S248
				AC200V	FHA-17C-50 / 100 / 160-US250 / E250 / S248, FHA-25C-100 / 160-US250 / E250 / S248, FHA-32C-160-US250 / E250 / S248, FHA-40C-100 / 160-US250 / E250 / S248
RTL-230-36	100-240	12	36	AC100V	FHA-25C-50-US250 / E250 / S248, FHA-32C-50 / 100-US250 / E250 / S248
				AC200V	FHA-40C-50-US250 / E250 / S248
RTL-230-40	100-240	20	40	AC200V	-

### •AC Digital Servo Drive REL Series

MODEL	Vac	Ic (Apk)	Ip (Apk)	Supply Voltage	Combination Actuator
REL-230-18	100-240	6	18	AC100/200V	FHA-8C-30 / 50 / 100-US200 / 12S17b / E200, FHA-11C-30 / 50 / 100-US200 / 12S17b / E200, FHA-14C-30 / 50 / 100-US200 / 12S17b / E200
				AC100V	FHA-17C-50 / 100 / 160-US250 / E250 / S248, FHA-25C-100 / 160-US250 / E250 / S248, FHA-32C-160-US250 / E250 / S248
				AC200V	FHA-17C-50 / 100 / 160-US250 / E250 / S248, FHA-25C-50 / 100 / 160-US250 / E250 / S248, FHA-32C-50 / 100 / 160-US250 / E250 / S248, FHA-40C-100 / 160-US250 / E250 / S248
REL-230-36	100-240	12	36	AC100V	FHA-25C-50-US250 / E250 / S248, FHA-32C-50 / 100-US250 / E250 / S248
				AC200V	FHA-40C-50-US250 / E250 / S248
REL-230-18	100-240	6	18	AC200V	SHA-20SG-51 / 81 / 101 / 121 / 161, SHA-20CG-50 / 80 / 100 / 120 / 160, SHA-25SG-51 / 81 / 101 / 121 / 161, SHA-25CG-50 / 80 / 100 / 120 / 160, SHA-32SG-161, SHA-32CG-160
REL-230-36	100-240	12	36		SHA-32SG-51 / 81 / 101 / 121, SHA-32CG-50 / 80 / 100 / 120, SHA-40SG-121 / 161, SHA-40CG-120 / 160
REL-230-40	100-240	20	40		SHA-40SG-51 / 81 / 101, SHA-40CG-50 / 80 / 100

# Servo Drivers



	HA-800A
	HA-800B
	HA-800C

## •Servo Driver Specifications

### •AC Servo Digital Drivers HA-800 Series

Item	Model	HA-800□-1	HA-800□-3	HA-800□-6	HA-800□-24
Rated Current*		1.5A	3.0A	6.0A	24.0A
Maximum Current*		4.0A	9.5A	19.0A	55.0A
Power Supply	Main Circuit	AC100~115V (Single phase) or AC200~230V (Single phase/3 phases) +10~-15%			AC200~230V (3 phases) +10~-15%
	Control Circuit	AC100~115V (Single phase) or AC200~230V (Single phase) +10~-15%			AC200~230V (Single phase) +10~-15%
Power Supply Frequency		50/60Hz			
Environmental Conditions		:0~50°C, -20~65°C, :95%RH Operating temperature: 0 to 50°C. Storage temperature: 20 to 65°C. Operating/Storage humidity: 95% RH or less and no condensation. Resistance to vibration: 4.9m/s <sup>2</sup> (Frequency: 10 to 55Hz). Shock resistance: 98m/s <sup>2</sup> . Ambient atmosphere: There should be no dust, metal powder, corrosive gas, flammable gas and oil mist.			
Control Mode		Position control, speed control, torque control (Available to change from I/O)			
Position Command Pulse		Line driver type: maximum response frequency. 2-pulse system, 1-pulse system: 2-phase pulse system: 200kHz Open collector type: maximum response frequency 200kHz			
Monitor Terminal		3ch motor rpm, current command, general-purpose output (parameter selection)			
Regenerative Processing	External regenerative resistance Mounting terminal attached	Regenerative resistance installed Mounting terminal for the external regenerative resistance attached			
Regenerative Resistance Absorption Power	-	3W Max	8W Max	90W Max	
Surge Current Suppress Function		Built-in (CPU control by the main circuit voltage monitoring)			
Weight		1kg	1.2kg	5.8kg	

\* The values shown represent the driver rated and maximum currents. Currents are adjusted to match the actuator current ratings before shipment.

### •HA-800B (MECHATROLINK Compatible) Communication Specification

Item	Specification
MECHATROLINK Version	MECHATROLINK-II
Transmission Speed	10Mbps
Maximum Transmission Distance	50m
Minimum Distance Between Channels	0.5m
Transmission Medium	Shielded twist pair cable (Two-core)
Number of Connected Station	Max: 30 slave stations
Topology	Bus
Communication Cycle	1, 1.5, 2, 3, 4, 5ms
Communication Method	Master-slave full synchronization
Encoding	Manchester encoding
Data Length	17 bytes/32 bytes, selectable
Number of Connectable Units	Max: 30 units

- 1 A repeater is required when communicating with 17 or more drives or if the total distance is 30m or longer when communicating with 16 or more drives. The maximum allowable number of units connected depends on the communication cycle setting and the number of allowable retries. For details, please see MECHATROLINK Association web site (<http://www.mechatrolink.org>).
- 2 Use MP2300 (Yaskawa Electric) controller.
- 3 Be sure to use the dedicated cable. Do not use commercially available USB cable.
- 4 When CC-Link Ver 1.00 compatible cable coexists: The total cable extension and the inter-office cable length will be the specification of Ver 1.00.

### •HA-800C (CC-LINK Compatible) Communication Specification

Item	Specification					
CC-LINK Version	Ver1.10					
Station Type	Remote device station					
Communication Speed	10M/5M/2.5M/625K/156Kbps					
Communication Method	Broadcast polling method					
Synchronization Method	Frame synchronization method					
Encoding Method	NRZI					
Transmission Path Format	Bus format (EIA RS-485 compliant)					
Error Control Method	CRC (X <sup>16</sup> +X <sup>12</sup> +X <sup>6</sup> +1)					
Connection Cable	CC-Link, Ver.1.10 compatible cable (Shielded twist pair cable (Three-core))					
Transmission Format	HDL compliant					
Remote Channel	1~64					
Number of Occupied Stations	1 station, 2 station					
Cable Length	Communication Speed	156kbps	625kbps	2.5Mbps	5Mbps	10Mbps
	Maximum Total Cable Extension	1,200m	900m	400m	160m	100m
	Cable Length	0.2m or longer				
Number of Connectable Units	Maximum 42 units with remote device station only, can be shared with other devices.					



# Servo Drivers



## •Servo Driver Specifications

### •AC Servo Digital Drivers (DC24V) HA-680 Series

Item	Model	HA-680-4-24		HA-680-6-24
Rated Current*		1.8A	3.9A	6.0A
Maximum Current*		3.4A	8.4A	16.5A
Power Supply	Main Circuit	DC24V(20~28V)		
	Control Curcuit	DC24V(20~28V)		
Control System		Sine wave PWM control, switching frequency: 12.5kHz		
Control Mode		Position control, speed control, torque control		
Weight		230g		

\* The values shown represent the driver rated and maximum currents. Currents are adjusted to match the actuator current ratings before shipment.

### •AC Servo Digital Drivers (DC24V) HA-680ML/CL

Item	Model	HA-680ML-4-24 HA-680ML-6-24	HA-680CL-4-24 HA-680CL-6-24	HA-680ML-4B-24 HA-680ML-6B-24	HA-680CL-4B-24 HA-680CL-6B-24
Power Source Voltage	Main Circuit	DC24V(20~28V)			
	Control Curcuit	DC24V(20~28V)			
Control System		Sine wave PWM method, switching frequency: 12.5kHz			
Encoder		4-line spec., serial transmission method, line driver input		14-line spec., line driver input	
Input/Output Signal		DI: 5 Points (Insulation by photo-coupler), DO:4 Points (Insulation by photo-coupler)			
Encoder Monitor		Phases A, B, Z line driver output			
Control Mode		Position control			
Weight		MECHATROLINK compatible: 260g, CC-Link compatible: 270g			

Note: Parameter settings for the driver are adjusted to match a specific actuator before shipment. This driver cannot be used in combination with a different actuator.

### •HA-680ML (MECHATROLINK Compatible) Communication Specification

Item	Specification
MECHATROLINK Version	MECHATROLINK-II
Transmission Speed	10Mbps
Maximum Transmission Distance	50m
Minimum Distance Between Channels	0.5m
Transmission Medium	Shielded twist pair cable (Two-core)
Number of Connected Station	Max: 30 slave stations
Topology	Bus
Communication Cycle	1, 2, 3, 4, 5ms
Communication Method	Master-slave full synchronization
Encoding	Manchester encoding
Data Length	17 bytes/32 bytes, selectable
Number of Connectable Units	Max: 30 units

1 A repeater is required when communication with 17 units or more is performed or the total extended distance is 30m or longer when communication with 16 units or more is performed. The maximum number of connectable units restricted through setting communication cycle and the number of retry. For details, please see MECHATROLINK Association web site (<http://www.mechatrolink.org>).

### •HA-680CL (CC-LINK Compatible) Communication Specification

Item	Specification					
CC-LINK Version	Ver1.10					
Station Type	Remote device station					
Communication Speed	10M/5M/2.5M/625K/156Kbps					
Communication Method	Broadcast polling method					
Synchronization Method	Frame synchronization method					
Encoding Method	NRZI					
Transmission Path Format	Bus format (EIA RS-485 compliant)					
Error Control Method	CRC (X <sup>16</sup> +X <sup>12</sup> +X <sup>6</sup> +1)					
Connection Cable	CC-Link, Ver.1.10 compatible cable (Shielded twist pair cable (Three-core))					
Transmission Format	HDLC compliant					
Remote Control	1~64					
Number of Occupied Stations	1 station					
Cable Length	Communication Speed	156kbps	625kbps	2.5Mbps	5Mbps	10Mbps
	Maximum Total Cable Extension	1,200m	900m	400m	160m	100m
	Cable Length	0.2m or longer				
Number of Connectable Units	Maximum 42 units with remote device station only, can be shared with other devices.					

## Recommended Driver

### •Combinations with Actuator and Servo Drive

#### Linear Actuators

Series	Model No.	Servo Drive	Voltage
LA	30	DCJ-055-09 DDP-090-09 DEP-090-09	Input: DC20V
	32		
LAH	46	-	
	80		
LBC	25	REL-230-18, RTL-230-18	

#### Galvano Optical Scanner

Series	Model No.	Servo Drive
LSA	All models	PSM-130



Cup Type  
CSF Series



The Harmonic Drive® CSF gears can be directly integrated into your machinery/ equipment. Available in a variety of sizes and ratios, you can select the unit that is most suitable for your needs.

- Zero backlash
- Compact design
- High torque capacity
- High torsional stiffness
- High positioning accuracy
- Housed configuration is available (see p. 40)

$L_{10}$  Life: 7,000 h

•CSF Series Ratings

Item Size	Reduction Ratio	Rated Torque at 2000rpm		Limit for Repeated Peak Torque		Limit for Momentary Peak Torque	
		Nm	In-lb	Nm	In-lb	Nm	In-lb
8	30	0.9	8	1.8	16	3.3	29
	50	1.8	16	3.3	29	6.6	58
	100	2.4	21	4.8	42	9.0	80
11	30	2.2	19	4.5	40	8.5	75
	50	3.5	31	8.3	73	17	150
	100	5.0	44	11	97	25	221
14	30	4.0	35	9.0	80	17	150
	50	5.4	48	18	159	35	310
	80	7.8	69	23	204	47	416
17	30	8.8	78	16	142	30	266
	50	16	142	34	301	70	620
	80	22	195	43	381	87	770
20	30	15	133	27	239	50	443
	50	25	221	56	496	98	867
	80	34	301	74	655	127	1124
25	30	27	239	50	443	95	841
	50	39	345	98	867	186	1646
	80	63	558	137	1212	255	2257
32	30	54	478	100	885	200	1770
	50	76	673	216	1912	382	3381
	80	118	1044	304	2690	568	5027
40	30	137	1212	333	2947	647	5726
	50	137	1212	353	3124	686	6071
	80	137	1212	372	3292	686	6071
45	50	176	1558	500	4425	950	8408
	80	313	2770	706	6248	1270	11240
	100	353	3124	755	6682	1570	13895
50	120	402	3558	823	7284	1760	15576
	160	402	3558	882	7806	1910	16904
	50	245	2168	715	6328	1430	12656
58	80	372	3292	941	8328	1860	16461
	100	470	4160	980	8673	2060	18231
	120	529	4682	1080	9558	2060	18231
65	160	529	4682	1180	10443	2450	21683
	50	353	3124	1020	9027	1960	17346
	80	549	4859	1480	13098	2450	21683
80	100	696	6160	1590	14072	3180	28143
	120	745	6593	1720	15222	3330	29471
	160	745	6593	1840	16284	3430	30356
90	50	490	4337	1420	12567	2830	25046
	80	745	6593	2110	18674	3720	32922
	100	951	8416	2300	20355	4750	42038
100	120	951	8416	2510	22214	4750	42038
	160	951	8416	2630	23276	4750	42038
	50	872	7717	2440	21594	4870	43100
110	80	1320	11682	3430	30356	6590	58322
	100	1700	15045	4220	37347	7910	70004
	120	1990	17612	4590	40622	7910	70004
120	160	1990	17612	4910	43454	7910	70004
	50	1180	10443	3530	31241	6660	58941
	80	1550	13718	3990	35312	7250	64163
130	100	2270	20090	5680	50268	9020	79827
	120	2570	22745	6160	54516	9800	86730
	160	2700	23895	6840	60534	11300	100005
140	50	1580	13983	4450	39383	8900	78765
	80	2380	21063	6060	53631	11600	102660
	100	2940	26019	7350	65048	14100	124785
150	120	3180	28143	7960	70446	15300	135405
	160	3550	31418	9180	81243	15500	137175

Item Size	Reduction Ratio	Rated Torque at 2000rpm		Limit for Repeated Peak Torque		Limit for Momentary Peak Torque	
		Nm	In-lb	Nm	In-lb	Nm	In-lb
45	50	176	1558	500	4425	950	8408
	80	313	2770	706	6248	1270	11240
	100	353	3124	755	6682	1570	13895
50	120	402	3558	823	7284	1760	15576
	160	402	3558	882	7806	1910	16904
	50	245	2168	715	6328	1430	12656
58	80	372	3292	941	8328	1860	16461
	100	470	4160	980	8673	2060	18231
	120	529	4682	1080	9558	2060	18231
65	160	529	4682	1180	10443	2450	21683
	50	353	3124	1020	9027	1960	17346
	80	549	4859	1480	13098	2450	21683
80	100	696	6160	1590	14072	3180	28143
	120	745	6593	1720	15222	3330	29471
	160	745	6593	1840	16284	3430	30356
90	50	490	4337	1420	12567	2830	25046
	80	745	6593	2110	18674	3720	32922
	100	951	8416	2300	20355	4750	42038
100	120	951	8416	2510	22214	4750	42038
	160	951	8416	2630	23276	4750	42038
	50	872	7717	2440	21594	4870	43100
110	80	1320	11682	3430	30356	6590	58322
	100	1700	15045	4220	37347	7910	70004
	120	1990	17612	4590	40622	7910	70004
120	160	1990	17612	4910	43454	7910	70004
	50	1180	10443	3530	31241	6660	58941
	80	1550	13718	3990	35312	7250	64163
130	100	2270	20090	5680	50268	9020	79827
	120	2570	22745	6160	54516	9800	86730
	160	2700	23895	6840	60534	11300	100005
140	50	1580	13983	4450	39383	8900	78765
	80	2380	21063	6060	53631	11600	102660
	100	2940	26019	7350	65048	14100	124785
150	120	3180	28143	7960	70446	15300	135405
	160	3550	31418	9180	81243	15500	137175

•Dimensions

Unit: mm

Size	8	11	14	17	20	25	32	40
Symbol								
øA	30	40	50	60	70	85	110	135
B	22.1	25.8	28.5	32.5	33.5	37	44	53

Size	45	50	58	65	80	90	100
Symbol							
øA	155	170	195	215	265	300	330
B	58.5	64	75.5	83	101	112.5	125

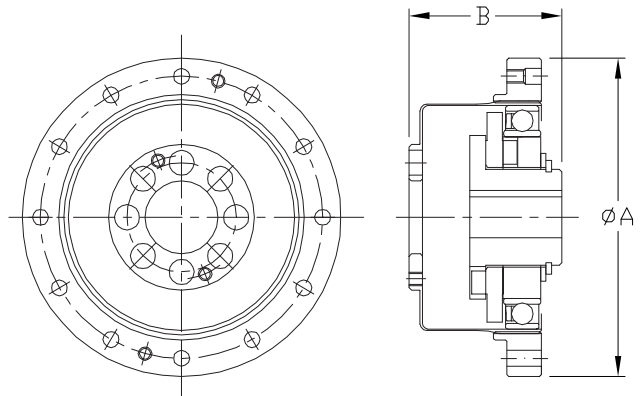

# Cup Type - High Torque CSG Series



CSG is available in 10 sizes with gear reduction ratios from 50:1 to 160:1. CSG high torque series was based on our CSF standard torque series with the goal of upgrading load capacity, strength & reliability and extending service life.

- Zero backlash
- Compact and simple design
- High torque capacity
- High torsional stiffness
- High positioning accuracy
- Housed unit type is available (see p. 42)
- 30% higher torque than a CSF unit

$L_{10}$  Life: 10,000 h

## •Performance comparison of CSF and CSG Series Harmonic Drive® gearing

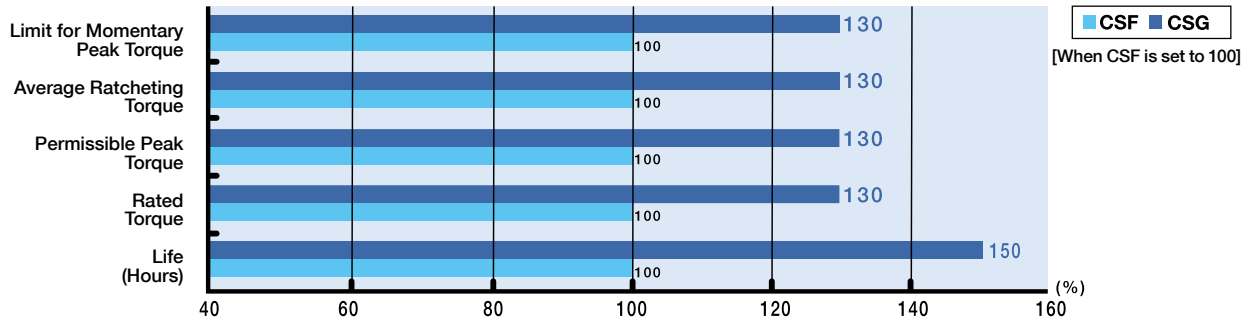

## •CSG Series Ratings

Item Size	Reduction Ratio	Rated Torque at 2000rpm		Limit for Repeated Peak Torque		Limit for Momentary Peak Torque	
		Nm	In-lb	Nm	In-lb	Nm	In-lb
14	50	7.0	62	23	204	46	407
	80	10	89	30	266	61	540
	100	10	89	36	319	70	620
17	50	21	186	44	389	91	805
	80	29	257	56	496	113	1000
	100	31	274	70	620	143	1266
20	50	33	292	73	646	127	1124
	80	44	389	96	850	165	1460
	100	52	460	107	947	191	1690
25	50	51	451	127	1124	242	2142
	80	82	726	178	1575	332	2938
	100	87	770	204	1805	369	3266
32	50	99	876	281	2487	497	4398
	80	153	1354	395	3496	738	6531
	100	178	1575	433	3832	841	7443

Item Size	Reduction Ratio	Rated Torque at 2000rpm		Limit for Repeated Peak Torque		Limit for Momentary Peak Torque	
		Nm	In-lb	Nm	In-lb	Nm	In-lb
40	50	178	1575	523	4629	892	7894
	80	268	2372	675	5974	1270	11240
	100	345	3053	738	6531	1400	12390
	120	382	3381	802	7098	1530	13541
45	50	229	2027	650	5753	1235	10930
	80	407	3602	918	8124	1651	14611
	100	459	4062	982	8691	2041	18063
	120	523	4629	1070	9470	2288	20249
50	50	229	2027	650	5753	1235	10930
	80	407	3602	918	8124	1651	14611
	100	459	4062	982	8691	2041	18063
	120	523	4629	1070	9470	2288	20249
58	50	229	2027	650	5753	1235	10930
	80	407	3602	918	8124	1651	14611
	100	459	4062	982	8691	2041	18063
	120	523	4629	1070	9470	2288	20249
65	50	229	2027	650	5753	1235	10930
	80	407	3602	918	8124	1651	14611
	100	459	4062	982	8691	2041	18063
	120	523	4629	1070	9470	2288	20249

## •Dimensions

Symbol	Size	14	17	20	25	32	40	45	50	58	65
	$\phi A$		50	60	70	85	110	135	155	170	195
B		28.5	32.5	33.5	37	44	53	58.5	64	75.5	83

Unit: mm

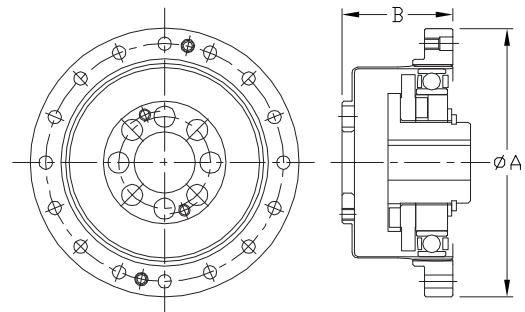

Cup Type - Super Flat  
**CSD Series**



The ultra-flat CSD precision gears are available in seven sizes, opening up new applications for motion control speed reducers.

- Zero backlash
- Extremely high positioning accuracy
- Excellent Repeatability
- Superior axial compactness
- Hollow through bore, also available with extra large through bore

$L_{10}$  Life: 7,000 h

•CSD Series Ratings

Item Size	Reduction Ratio	Rated Torque at 2000 rpm		Limit for Repeated Peak Torque		Permissible Maximum Monetary Torque	
		Nm	In-lb	Nm	In-lb	Nm	In-lb
14	50	3.7	33	12	106	24	212
	100	5.4	48	19	168	31	274
17	50	11	97	23	204	48	425
	100	16	142	37	327	55	487
20	50	17	150	39	345	69	611
	100	28	248	57	504	76	673
	160	28	248	64	566	76	673
25	50	27	239	69	611	127	1124
	100	47	416	110	974	152	1345
	160	47	416	123	1089	152	1345
32	50	53	469	151	1336	268	2372
	100	96	850	233	2062	359	3177
	160	96	850	261	2310	359	3177
40	50	96	850	281	2487	480	4248
	100	185	1637	398	3522	694	6142
	160	206	1823	453	4009	694	6142
50	50	172	1522	500	4425	1000	8850
	100	329	2912	686	6071	1440	12744
	160	370	3275	823	7284	1577	13956

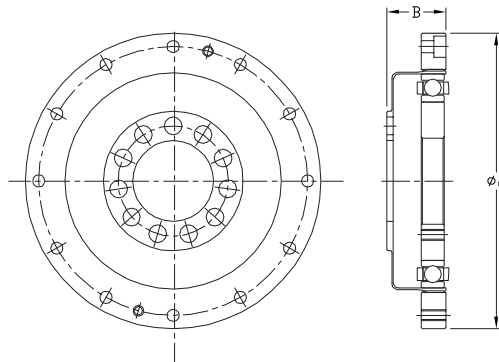

•Dimensions

Unit: mm

Size Symbol	14	17	20	25	32	40	50
ø A	50	60	70	85	110	135	170
B	11	12.5	14	17	22	27	33



# FB and FR Series

**FB**

**FR**

Pancake gears consist of four main parts: Wave Generator, Flexspline, Dynamic Spline, and Circular Spline. Extremely flat, these pancake gears offer the design engineer high ratios in extremely compact configurations.

- Flat profile
- Easily adapted to customer supplied assembly
- FB uses single wave generator bearing
- FR is heavy duty version of the FB
- FR uses double wave generator bearing

**L<sub>10</sub> Life: 3,000 h**

## •FB, FR Series Ratings

Size	Ratio	Rated Torque at 2000 rpm			
		FB Series		FR Series	
		Nm	In-lb	Nm	In-lb
14	50	2.6	23	4.4	39
	88	4.9	43	5.9	52
	100	5.9	52	7.8	69
	110	5.9	52	7.8	69
20	50	14	124	25	221
	80	17	150	34	301
	100	22	195	40	354
	128	24	212	40	354
25	160	24	212	40	354
	50	23	204	39	345
	80	31	274	56	496
	100	39	345	67	593
25	120	39	345	67	593
	160	39	345	67	593
	200	-	-	67	593
	200	-	-	67	593
32	50	44	389	76	673
	78	63	558	108	956
	100	82	726	137	1212
	131	82	726	137	1212
	157	82	726	137	1212
	200	-	-	137	1212
	260	-	-	137	1212
40	50	88	779	137	1212
	80	118	1044	196	1735
	100	157	1389	255	2257
	128	167	1478	294	2602
	160	167	1478	294	2602
	200	-	-	294	2602
	258	-	-	294	2602

Size	Ratio	Rated Torque at 2000 rpm			
		FB Series		FR Series	
		Nm	In-lb	Nm	In-lb
50	80	216	1912	363	3213
	100	284	2513	470	4160
	120	304	2690	559	4947
	160	304	2690	559	4947
	200	-	-	559	4947
50	242	-	-	559	4947
	78	-	-	745	6593
	104	-	-	1070	9470
	132	-	-	1070	9470
	158	-	-	1070	9470
65	208	-	-	1070	9470
	260	-	-	1070	9470
	80	-	-	1320	11682
	96	-	-	1660	14691
	128	-	-	2300	20355
80	160	-	-	2350	20798
	194	-	-	2350	20798
	258	-	-	2350	20798
	320	-	-	2350	20798
	80	-	-	2330	20621
100	100	-	-	3200	28320
	120	-	-	3890	34427
	160	-	-	4470	39560
	200	-	-	4470	39560
	242	-	-	4470	39560
100	320	-	-	4470	39560

## •Dimensions

Unit: mm

Size	Symbol	FB	FR
	∅A	B	C
14	50	10.5	18
20	70	12.5	25
25	85	16.5	29
32	110	20.5	37
40	135	27.0	43
50	170	33.0	53
65	215	-	71
80	265	-	83
100	330	-	101

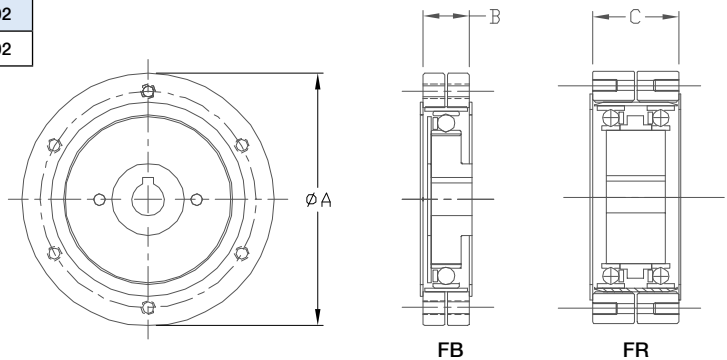

## Silk Hat SHF Series



SHF is a silk hat, component set gear available with a large hollow through bore. It provides exceptional positioning accuracy in a compact design.

- Zero backlash
- Hollow bore units available
- Compact and simple design
- High torque capacity
- High positioning accuracy
- High torsional stiffness
- Housed version of this component set is available (see p. 50)

$L_{10}$  Life: 7,000 h

### •SHF Series Ratings

Item Size	Reduction Ratio	Rated Torque at 2000rpm		Limit for Repeated Peak Torque		Limit for Momentary Peak Torque	
		Nm	In-lb	Nm	In-lb	Nm	In-lb
14	30	4.0	35	9.0	80	17	150
	50	5.4	48	18	159	35	310
	80	7.8	69	23	204	47	416
	100	7.8	69	28	248	54	478
17	30	8.8	78	16	142	30	266
	50	16	142	34	301	70	620
	80	22	195	43	381	87	770
	100	24	212	54	478	110	974
20	120	24	212	54	478	86	761
	30	15	133	27	239	50	443
	50	25	221	56	496	98	867
	80	34	301	74	655	127	1124
25	100	40	354	82	726	147	1301
	120	40	354	87	770	147	1301
	160	40	354	92	814	147	1301
	30	27	239	50	443	95	841
32	50	39	345	98	867	86	1646
	80	63	558	137	1212	255	2257
	100	67	593	157	1389	284	2513
	120	67	593	167	1478	304	2690
40	160	67	593	176	1558	314	2779
	50	76	673	216	1912	382	3381
	80	118	1044	230	2036	568	5027
	100	137	1212	333	2947	647	5726
45	120	137	1212	353	3124	686	6071
	160	137	1212	372	3292	686	6071
	50	245	2168	715	6328	1430	12656
	80	372	3292	941	8328	1860	16461
50	100	470	4160	980	8673	2060	18231
	120	529	4682	1080	9558	2060	18231
	160	529	4682	1180	10443	2450	21683
	50	353	3124	823	7284	1760	15576
58	80	549	4859	1480	13098	2450	21683
	100	696	6160	1590	14072	3180	28143
	120	745	6593	1720	15222	3330	29471
	160	745	6593	1840	16284	3430	30356

### •Dimensions

Unit: mm

Size	14	17	20	25	32	40	45	50	58
Symbol									
$\phi A$	50	60	70	85	110	135	155	170	195
B	28.5	32.5	33.5	37	44	53	58.5	64	75.5

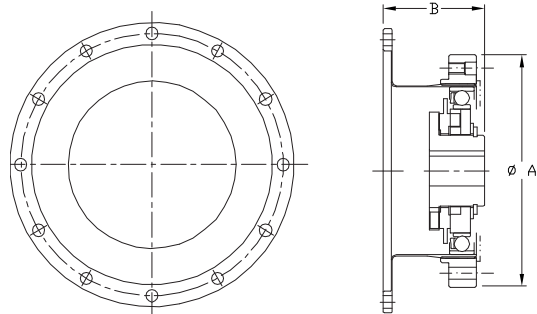

# SHG Series



SHG is a high torque, silk hat, component set gear available with a large hollow through bore. It provides exceptional positioning accuracy in a compact design.

- Zero backlash
- Hollow bore units available
- Excellent positioning accuracy
- Compact and simple design
- High torque capacity
- High torsional stiffness
- 30% higher torque rating than SHF series

$L_{10}$  Life: 10,000h

## •Performance comparison of SHF and SHG Series Harmonic Drive® gearing

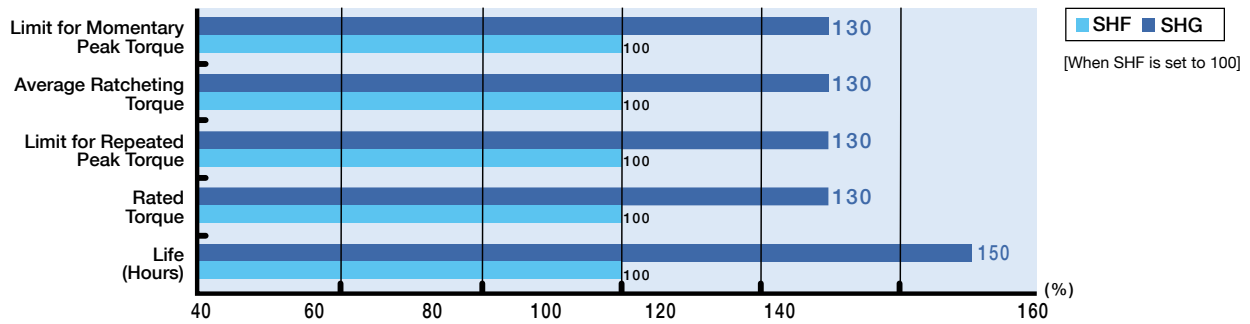

## •SHG Series Ratings

Item	Reduction Ratio	Rated Torque at 2000rpm		Limit for Repeated Peak Torque		Limit for Momentary Peak Torque	
		Nm	In-lb	Nm	In-lb	Nm	In-lb
14	50	7.0	62	23	204	46	407
	80	10	89	30	266	61	540
	100	10	89	36	319	70	620
17	50	21	186	44	389	91	805
	80	29	257	56	496	113	1000
	100	31	274	70	620	143	1266
20	50	33	292	73	646	127	1124
	80	44	389	96	850	165	1460
	100	52	460	107	947	191	1690
25	50	51	451	127	1124	242	2142
	80	82	726	178	1575	332	2938
	100	87	770	204	1805	369	3266
32	50	99	876	281	2487	497	4398
	80	153	1354	395	3496	738	6531
	100	178	1575	433	3832	841	7443

Item	Reduction Ratio	Rated Torque at 2000rpm		Limit for Repeated Peak Torque		Limit for Momentary Peak Torque	
		Nm	In-lb	Nm	In-lb	Nm	In-lb
40	50	178	1575	523	4629	892	7894
	80	268	2372	675	5974	1270	11240
	100	345	3053	738	6531	1400	12390
	120	382	3381	802	7098	1530	13541
45	50	229	2027	650	5753	1235	10930
	80	407	3602	918	8124	1651	14611
	100	459	4062	982	8691	2041	18063
	120	523	4629	1070	9470	2288	20249
50	50	229	2027	650	5753	1235	10930
	80	484	4283	1223	10824	2418	21399
	100	611	5407	1274	11275	2678	23700
	120	688	6089	1404	12425	2678	23700
58	50	688	6089	1534	13576	3185	28187
	80	714	6319	1924	17027	3185	28187
	100	905	8009	2067	18293	4134	36586
	120	969	8576	2236	19789	4329	38312
65	50	969	8576	2392	21169	4459	39462
	80	969	8576	2743	24276	4836	42799
	100	1236	10939	2990	26462	6175	54649
	120	1236	10939	3263	28878	6175	54649

## •Dimensions

Unit: mm

Size	14	17	20	25	32	40	45	50	58	65
Symbol										
$\phi A$	50	60	70	85	110	135	155	170	195	215
B	28.5	32.5	33.5	37	44	53	58.5	64	75.5	83

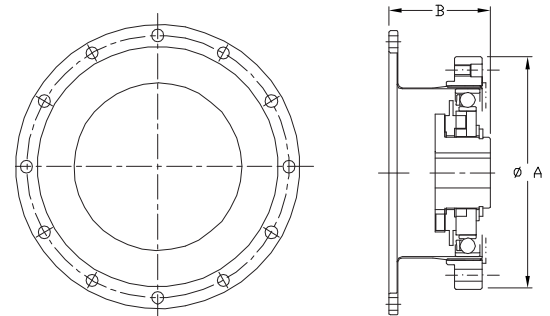

Gear Unit

# CSF-2UH Series



CSF-2UH is a housed component gear set combined with a precision cross roller output bearing & flange. It is a very compact, robust and easy to use gearhead solution.

- Zero backlash
- Compact and simple design
- High torque capacity
- High torsional stiffness
- High positioning accuracy

**L<sub>10</sub> Life: 7,000h**

## •CSF Series Ratings

Item Size	Reduction Ratio	Rated Torque at 2000rpm		Limit for Repeated Peak Torque		Limit for Momentary Peak Torque	
		Nm	In-lb	Nm	In-lb	Nm	In-lb
14	30	4.0	35	9.0	80	17	150
	50	5.4	48	18	159	35	310
	80	7.8	69	23	204	47	416
	100	7.8	69	28	248	54	478
17	30	8.8	78	6	142	30	266
	50	16	142	34	301	70	620
	80	22	195	43	381	87	770
	100	24	212	54	478	108	974
20	120	24	212	54	478	86	761
	30	15	133	27	239	50	443
	50	25	221	56	496	98	867
	80	34	301	74	655	127	1124
25	100	40	354	82	726	147	1301
	120	40	354	87	770	147	1301
	160	40	354	92	814	147	1301
	30	27	239	50	443	95	841
32	50	39	345	98	867	186	1646
	80	63	558	137	1212	255	2257
	100	67	593	157	1389	284	2513
	120	67	593	167	1478	304	2690
40	160	67	593	176	1558	314	2779
	30	54	478	100	885	200	1770
	50	76	673	216	1912	382	3381
	80	118	1044	304	2036	568	5027
50	100	137	1212	333	2947	647	5726
	120	137	1212	353	3124	686	6072
	160	137	1212	372	3292	686	6072

Item Size	Reduction Ratio	Rated Torque at 2000rpm		Limit for Repeated Peak Torque		Limit for Momentary Peak Torque	
		Nm	In-lb	Nm	In-lb	Nm	In-lb
40	50	137	1212	402	3558	686	6072
	80	206	1823	519	4593	980	8674
	100	265	2345	568	5027	1080	9559
	120	294	2602	617	5460	1180	10444
	160	294	2602	647	5726	1180	10444
45	50	176	1558	500	4425	950	8408
	80	313	2770	706	6248	1270	11240
	100	353	3124	755	6682	1570	13896
	120	402	3558	823	7284	1760	15577
50	160	402	3558	882	7806	1910	16905
	50	245	2168	715	6328	1430	12657
	80	372	3292	941	8328	1860	16462
	100	470	4160	980	8673	2060	18233
58	120	529	4682	1080	9558	2060	18233
	160	529	4682	1180	10443	2450	21684
	50	353	3124	1020	9027	1960	17347
	80	549	4859	1480	13098	2450	21684
65	100	686	6160	1590	14072	3180	28145
	120	745	6593	1720	15222	3330	29473
	160	745	6593	1840	16284	3430	30358
	50	490	4337	1420	12567	2830	25048
80	745	6593	2110	18674	3720	32925	
	100	951	8416	2300	20355	4750	42041
	120	951	8416	2510	22214	4750	42041
	160	951	8416	2630	23276	4750	42041

## •Cross Roller Bearing Specification

Item Size	Basic Rated Load				Allowable Moment Load Mc		Moment Stiffness Km	
	Basic Dynamic Rated Load C		Basic Static Rated Load Co		Nm	In-lb	x 10 <sup>4</sup> Nm /rad	In-lb/arc-min
	x 10 <sup>3</sup> N	lb	x 10 <sup>3</sup> N	lb				
14	47	1057	60.7	1365	41	363	4.38	113
17	52.9	1189	75.5	1697	64	566	7.75	200
20	57.8	1299	90.0	2023	91	805	12.8	330
25	96.0	2158	151	3394	156	1381	24.2	623
32	150	3372	250	5620	313	2770	53.9	1388
40	213	4788	365	8205	450	3983	91.0	2343
45	230	5170	426	9576	686	6071	141	3631
50	348	7823	602	13533	759	6717	171	4403
58	518	11645	904	20322	1180	10443	283	7287
65	556	12499	1030	23154	1860	16461	404	10403

- "Basic dynamic rated load" is a constant stationary radial load that achieves a basic dynamic rated life of the bearing of one million revolutions.
- "Basic static rated load" is a static load that achieves a contact stress of a constant level (408kN/mm<sup>2</sup>) at the center of a contact zone between the rolling element receiving a maximum load and track.

• The moment stiffnesses are mean values.

## •Dimensions

Unit: mm

Size	14	17	20	25	32	40	45	50	58	65
Symbol										
øA	73	79	93	107	138	160	180	190	226	260
B	41	45	45.5	52	62	72.5	79.5	90	104.5	115

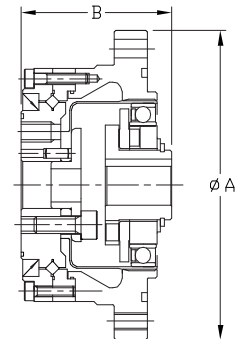
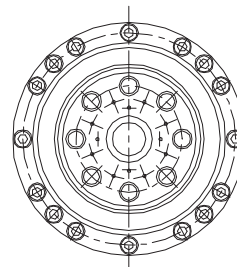

# Lightweight Gear Unit CSF-2UH-LW Series



LW indicates lightweight, the CSF-2UH is a housed component gear set combined with a precision cross roller output bearing & flange.

- Zero Backlash
- 30% average lower weight than Standard Series
- High Torque to Weight ratio
- Accuracy <1 arc-min
- High torsional stiffness
- High efficiency
- Robust cross roller output bearing
- Output flange for direct mounting of load

$L_{10}$  Life: 7,000 h

## •CSF-LW Series Ratings

Item Size	Gear Ratio	Rated Torque at 2000rpm		Limit for Repeated Peak Torque		Limit for Momentary Torque	
		Nm	In-lb	Nm	In-lb	Nm	In-lb
14	30	4.0	35	9.0	80	17	150
	50	5.4	48	18	159	35	310
	80	7.8	69	23	204	47	416
	100	7.8	69	28	248	54	478
17	30	8.8	78	16	142	30	266
	50	16	142	34	301	70	620
	80	22	195	43	381	87	770
	100	24	212	54	478	108	956
20	30	15	133	27	239	50	443
	50	25	221	56	496	98	867
	80	34	301	74	655	127	1,124
	100	40	354	82	726	147	1,301
25	30	27	239	50	443	95	841
	50	39	345	98	867	186	1,646
	80	63	558	137	1,213	255	2,257
	100	67	593	157	1,390	284	2,514
32	30	54	478	100	885	200	1,770
	50	76	673	216	1,912	382	3,381
	80	118	1,044	304	2,691	568	5,027
	100	137	1,213	333	2,947	647	5,726

Item Model No.	Gear Ratio	Rated Torque at 2000rpm		Limit for Repeated Peak Torque		Limit for Momentary Torque	
		Nm	In-lb	Nm	In-lb	Nm	In-lb
40	50	137	1,213	402	3,558	686	6,072
	80	206	1,823	519	4,594	980	8,674
	100	265	2,345	568	5,027	1,080	9,559
	120	294	2,602	617	5,461	1,180	10,444
	160	294	2,602	647	5,726	1,180	10,444
45	50	176	1,558	500	4,425	950	8,408
	80	313	2,770	706	6,249	1,270	11,240
	100	353	3,124	755	6,682	1,570	13,896
	120	402	3,558	823	7,284	1,760	15,577
	160	402	3,558	882	7,806	1,910	16,905
50	50	245	2,168	715	6,328	1,430	12,657
	80	372	3,292	941	8,329	1,860	16,462
	100	470	4,160	980	8,674	2,060	18,233
	120	529	4,682	1,080	9,559	2,060	18,233
	160	529	4,682	1,180	10,444	2,450	21,684
58	50	353	3,124	1,020	9,028	1,960	17,347
	80	549	4,859	1,480	13,099	2,450	21,684
	100	696	6,160	1,590	14,073	3,180	28,145
	120	745	6,594	1,720	15,223	3,330	29,473
	160	745	6,594	1,840	16,285	3,430	30,358
65	50	490	4,337	1,420	12,568	2,830	25,048
	80	745	6,594	2,110	18,675	3,720	32,925
	100	951	8,417	2,300	20,357	4,750	42,041
	120	951	8,417	2,510	22,215	4,750	42,041
	160	951	8,417	2,630	23,277	4,750	42,041

## •Cross Roller Bearing Specification

Item Size	Basic Rated Load				Allowable Moment Load Mc		Moment Stiffness Km	
	Basic Dynamic Rated Load C		Basic Static Rated Load Co		Nm	In-lb	x 10 <sup>4</sup> Nm/rad	In-lb/arc-min
	x 10 <sup>3</sup> N	lb	x 10 <sup>3</sup> N	lb				
14	47	1,057	60.7	1,365	33.6	297	3.6	32
17	52.9	1,189	75.5	1,697	52.5	465	6.4	57
20	57.8	1,299	90.0	2,023	74.6	660	10.5	93
25	96.0	2,158	151	3,395	128	1,133	19.8	175
32	150	3,372	250	5,620	257	2,275	44.2	391
40	213	4,788	365	8,206	369	3,266	74.6	660
45	230	5,171	426	9,577	563	4,983	116	1,027
50	348	7,823	602	13,534	622	5,505	140	1,239
58	518	11,645	904	20,323	838	7,417	201	1,779
65	556	12,499	1030	23,155	1,525	13,497	331	2,930

- "Basic dynamic rated load" is a constant stationary radial load that achieves a basic dynamic rated life of the bearing of one million revolutions.
- "Basic static rated load" is a static load that achieves a contact stress of a constant level (408kN/mm<sup>2</sup>) at the center of a contact zone between the rolling element receiving a maximum load and track.
- The moment stiffnesses are mean values.

## •Dimensions

Size	14	17	20	25	32	40	45	50	58	65
Symbol										
øA	73	79	93	107	138	160	180	190	226	260
B	41	45	45.5	52	62	72.5	79.5	90	104.5	115

Unit: mm

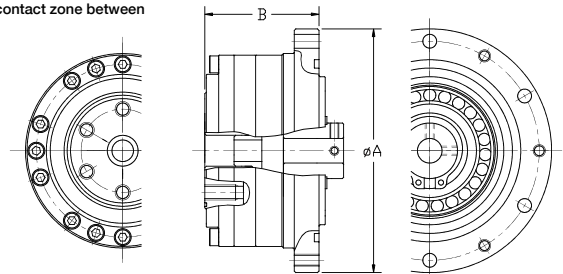

# High Torque Gear Unit CSG-2UH Series



CSG-2UH is a high torque housed component gear set combined with a precision cross roller output bearing & flange. It is a very compact, robust and easy to use gearhead solution.

- Zero backlash
- High torque capacity
- High torsional stiffness
- Compact and simple design
- High positioning accuracy
- 30% higher torque than a CSF unit

$L_{10}$  Life: 10,000h

## •CSG Series Ratings

Item	Reduction Ratio	Rated Torque at 2000rpm		Limit for Repeated Peak Torque		Limit for Momentary Peak Torque	
		Nm	In-lb	Nm	In-lb	Nm	In-lb
14	50	7.0	62	23	204	46	407
	80	10	89	30	266	61	540
	100	10	89	36	319	70	620
17	50	21	186	44	389	91	805
	80	29	257	56	496	113	1000
	100	31	274	70	620	143	1266
20	50	33	292	73	646	127	1124
	80	44	389	96	850	165	1460
	100	52	460	107	947	191	1690
25	50	51	451	127	1124	242	2142
	80	82	726	178	1575	332	2938
	100	87	770	204	1805	369	3266
32	50	99	876	281	2487	497	4399
	80	153	1354	395	3496	738	6532
	100	178	1575	433	3832	841	7443
40	50	178	1575	484	4283	892	7895
	80	268	2372	675	5974	1270	11240
	100	345	3053	738	6531	1400	12391
45	50	229	2027	650	5753	1235	10931
	80	407	3602	918	8124	1651	14613
	100	459	4062	982	8691	2041	18064
50	50	523	4629	1070	9470	2288	20250
	80	611	5407	1274	11275	2678	23702
	100	688	6089	1404	12425	2678	23702
58	50	688	6089	1534	13576	3185	28190
	80	714	6319	1924	17027	3185	28190
	100	905	8009	2067	18293	4134	36589
65	50	969	8576	2236	19789	4329	38315
	80	969	8576	2392	21169	4459	39465
	100	969	8576	2743	24276	4836	42802
65	50	1236	10939	2990	26462	6175	54653
	80	1236	10939	3263	28878	6175	54653
	100	1236	10939	3419	30258	6175	54653

Item	Reduction Ratio	Rated Torque at 2000rpm		Limit for Repeated Peak Torque		Limit for Momentary Peak Torque	
		Nm	In-lb	Nm	In-lb	Nm	In-lb
40	50	178	1575	523	4629	892	7895
	80	268	2372	675	5974	1270	11240
	100	345	3053	738	6531	1400	12391
45	50	229	2027	650	5753	1235	10931
	80	407	3602	918	8124	1651	14613
	100	459	4062	982	8691	2041	18064
50	50	523	4629	1070	9470	2288	20250
	80	611	5407	1274	11275	2678	23702
	100	688	6089	1404	12425	2678	23702
58	50	688	6089	1534	13576	3185	28190
	80	714	6319	1924	17027	3185	28190
	100	905	8009	2067	18293	4134	36589
65	50	969	8576	2236	19789	4329	38315
	80	969	8576	2392	21169	4459	39465
	100	969	8576	2743	24276	4836	42802
65	50	1236	10939	2990	26462	6175	54653
	80	1236	10939	3263	28878	6175	54653
	100	1236	10939	3419	30258	6175	54653

## •Cross Roller Bearing Specification

Item	Basic Rated Load				Allowable Moment Load Mc		Moment Stiffness Km	
	Basic Dynamic Rated Load C		Basic Static Rated Load Co		Nm	In-lb	x 10 <sup>4</sup> Nm /rad	In-lb/arc-min
	x 10 <sup>3</sup> N	lb	x 10 <sup>3</sup> N	lb				
14	47	1057	60.7	1365	41	363	4.38	113
17	52.9	1189	75.5	1697	64	566	7.75	200
20	57.8	1299	90.0	2023	91	805	12.8	330
25	96.0	2158	151	3394	156	1381	24.2	623
32	150	3372	250	5620	313	2770	53.9	1388
40	213	4788	365	8205	450	3983	91.0	2343
45	230	5170	426	9576	686	6071	141	3631
50	348	7823	602	13533	759	6717	171	4403
58	518	11645	904	20322	1180	10443	283	7287
65	556	12499	1030	23154	1860	16461	404	10403

- "Basic dynamic rated load" is a constant stationary radial load that achieves a basic dynamic rated life of the bearing of one million revolutions.
- "Basic static rated load" is a static load that achieves a contact stress of a constant level (408kN/mm<sup>2</sup>) at the center of a contact zone between the rolling element receiving a maximum load and track.

• The moment stiffnesses are mean values.

## •Dimensions

Unit: mm

Size	14	17	20	25	32	40	45	50	58	65
Symbol										
øA	73	79	93	107	138	160	180	190	226	260
B	41	45	45.5	52	62	72.5	79.5	90	104.5	115

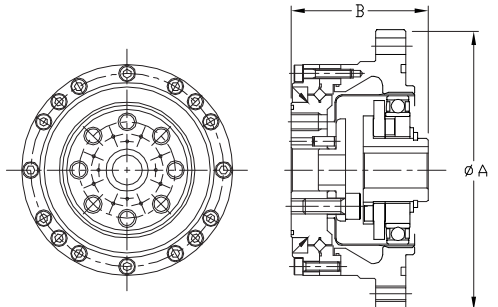



# High Torque, Lightweight Gear Unit

## CSG-2UH-LW Series



LW indicates lightweight. CSG-2UH is a high torque housed component gear set combined with a precision cross roller output bearing & flange. It is a very compact, robust and easy to use gearhead solution.

- Zero Backlash
- 30% average lower weight than Standard Series
- High Torque to Weight ratio
- Accuracy <1 arc-min
- High torsional stiffness
- High efficiency
- Robust cross roller output bearing
- Output flange for direct mounting of load

$L_{10}$  Life: 10,000h

### •CSG-LW Series Ratings

Item	Gear Ratio	Rated Torque at 2000rpm		Limit for Repeated Peak Torque		Limit for Momentary Torque	
		Nm	In-lb	Nm	In-lb	Nm	In-lb
14	50	7	62	23	204	46	407
	80	10	89	30	266	61	540
	100	10	89	36	319	70	620
17	50	21	186	44	389	91	805
	80	29	257	56	496	113	1,000
	100	31	274	70	620	143	1,266
20	50	33	292	73	646	127	1,124
	80	44	389	96	850	165	1,460
	100	52	460	107	947	191	1,690
25	50	51	451	127	1,124	242	2,142
	80	82	726	178	1,575	332	2,938
	100	87	770	204	1,806	369	3,266
32	50	99	876	281	2,487	497	4,399
	80	153	1,354	395	3,496	738	6,532
	100	178	1,575	433	3,832	841	7,443

Item	Gear Ratio	Rated Torque at 2000rpm		Limit for Repeated Peak Torque		Limit for Momentary Torque	
		Nm	In-lb	Nm	In-lb	Nm	In-lb
40	50	178	1,575	523	4,629	892	7,895
	80	268	2,372	675	5,974	1,270	11,240
	100	345	3,054	738	6,532	1,400	12,391
	120	382	3,381	802	7,098	1,530	13,542
45	50	229	2,027	650	5,753	1,235	10,931
	80	407	3,602	918	8,125	1,651	14,613
	100	459	4,062	982	8,691	2,041	18,064
	120	523	4,629	1,070	9,470	2,288	20,250
50	50	523	4,629	1,147	10,152	2,483	21,976
	80	484	4,284	1,223	10,824	2,418	21,401
	100	611	5,408	1,274	11,276	2,678	23,702
	120	688	6,089	1,404	12,426	2,678	23,702
58	50	688	6,089	1,534	13,577	3,185	28,190
	80	714	6,319	1,924	17,029	3,185	28,190
	100	905	8,010	2,067	18,294	4,134	36,589
	120	969	8,576	2,236	19,790	4,329	38,315
65	50	969	8,576	2,392	21,171	4,459	39,465
	80	969	8,576	2,743	24,278	4,836	42,802
	100	1,236	10,940	2,990	26,464	6,175	54,653
	120	1,236	10,940	3,263	28,880	6,175	54,653

### •Cross Roller Bearing Specification

Item	Basic Rated Load				Allowable Moment Load		Moment Stiffness Km	
	Basic Dynamic Rated Load C		Basic Static Rated Load Co		Nm	In-lb	x 10 <sup>4</sup> Nm /rad	In-lb/arc-min
	x 10 <sup>2</sup> N	lb	x 10 <sup>2</sup> N	lb				
14	47	1,057	60.7	1,365	33.6	297	3.6	32
17	52.9	1,189	75.5	1,697	52.5	465	6.4	57
20	57.8	1,299	90.0	2,023	74.6	660	10.5	93
25	96.0	2,158	151	3,395	128	1,133	19.8	175
32	150	3,372	250	5,620	257	2,275	44.2	391
40	213	4,788	365	8,206	369	3,266	74.6	660
45	230	5,170	426	9,577	563	4,983	116	1,027
50	348	7,823	602	13,534	622	5,505	140	1,239
58	518	11,645	904	20,323	838	7,417	201	1,779
65	556	12,499	1030	23,155	1,525	13,497	331	2,930

### •Dimensions

Unit: mm

Size	14	17	20	25	32	40	45	50	58	65
Symbol										
øA	73	79	93	107	138	160	180	190	226	260
B	41	45	45.5	52	62	72.5	79.5	90	104.5	115

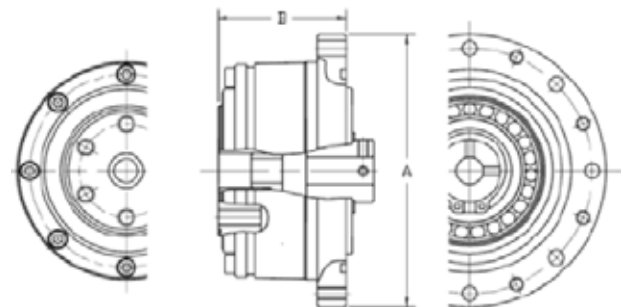

# High Torque Gear Unit CSG-2UK Series



CSG-2UK is a high torque fully sealed, high accuracy gear reducer ideally suited for machine tool applications.

- Zero backlash
- Compatible with Fanuc motors
- High torque capacity
- High torsional stiffness
- High positioning accuracy

$L_{10}$  Life: 10,000h

## •CSG Series Ratings

Item	Reduction Ratio	Rated Torque at 2000rpm		Limit for Repeated Peak Torque		Limit for Momentary Peak Torque	
		Nm	In-lb	Nm	In-lb	Nm	In-lb
25	50	51	451	127	1124	242	2142
	80	82	726	178	1575	332	2938
	100	87	770	204	1805	369	3266
	120	87	770	217	1920	395	3496
	160	87	770	229	2027	408	3611
32	50	99	876	281	2487	497	4399
	80	153	1354	395	3496	738	6532
	100	178	1575	433	3832	841	7443
	120	178	1575	459	4062	892	7895
	160	178	1575	484	4283	892	7895
40	50	178	1575	523	4629	892	7895
	80	268	2372	675	5974	1270	11240
	100	345	3053	738	6531	1400	12391
	120	382	3381	802	7098	1530	13542
	160	382	3381	841	7443	1530	13542

Item	Reduction Ratio	Rated Torque at 2000rpm		Limit for Repeated Peak Torque		Limit for Momentary Peak Torque	
		Nm	In-lb	Nm	In-lb	Nm	In-lb
45	50	229	2027	650	5753	1235	10931
	80	407	3602	918	8124	1651	14613
	100	459	4062	982	8691	2041	18064
	120	523	4629	1070	9470	2288	20250
	160	523	4629	1147	10151	2483	21976
58	80	714	6319	1924	17027	3185	28190
	100	905	8009	2067	18293	4134	36589
	120	969	8576	2236	19789	4329	38315
	160	969	8576	2392	21169	4459	39465
65	80	969	8576	2743	24276	4836	42802
	100	1236	10939	2990	26462	6175	54653
	120	1236	10939	3263	28878	6175	54653
	160	1236	10939	3419	30258	6175	54653

## •Cross Roller Bearing Specification

Item	Size	Basic Rated Load				Permissible Moment Load Mc		Moment Stiffness Km	
		Basic Dynamic Rated Load C		Basic Static Rated Load Co		Nm	In-lb	x 10 <sup>4</sup> Nm /rad	In-lb/arc-min
		x 10 <sup>3</sup> N	lb	x 10 <sup>3</sup> N	lb				
25	96.0	2158	151	3394	128	1133	19.8	512	
32	150	3372	250	5620	257	2274	44.2	1137	
40	213	4788	365	8205	369	3266	74.6	1918	
45	230	5170	426	9576	563	4983	116	2986	
58	518	11645	904	20322	838	7416	201	5173	
65	556	12499	1030	23154	1525	13496	331	9374	

- "Basic dynamic rated load" is a constant stationary radial load that achieves a basic dynamic rated life of the bearing of one million revolutions.
- "Basic static rated load" is a static load that achieves a contact stress of a constant level (408kN/mm<sup>2</sup>) at the center of a contact zone between the rolling element receiving a maximum load and track.
- The moment stiffnesses are mean values.

## •Dimensions

Unit: mm

Size	25	32	40	45	58	65
Symbol						
øA	107	138	160	180	226	260
B	66	75	85	102	120	129

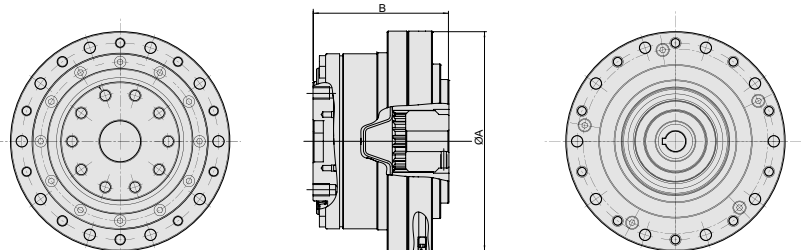

•Overview Drawing

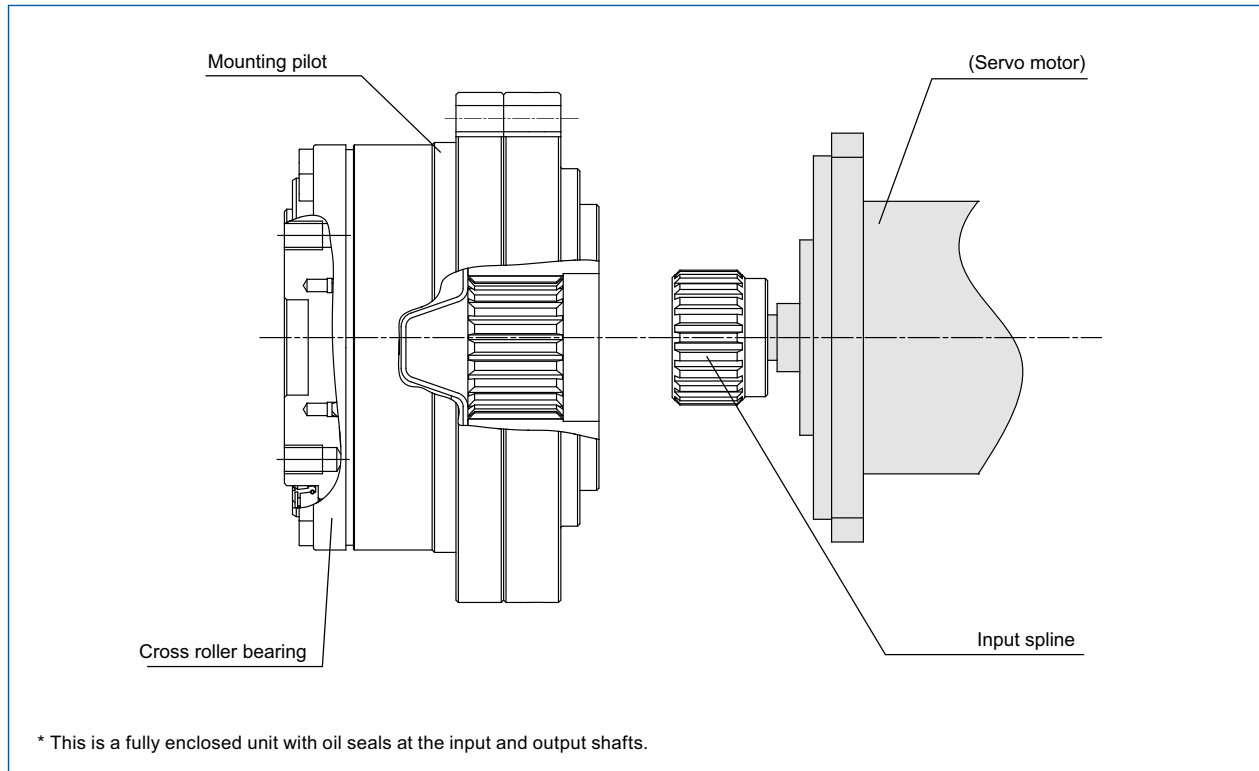

•Typical Assembly

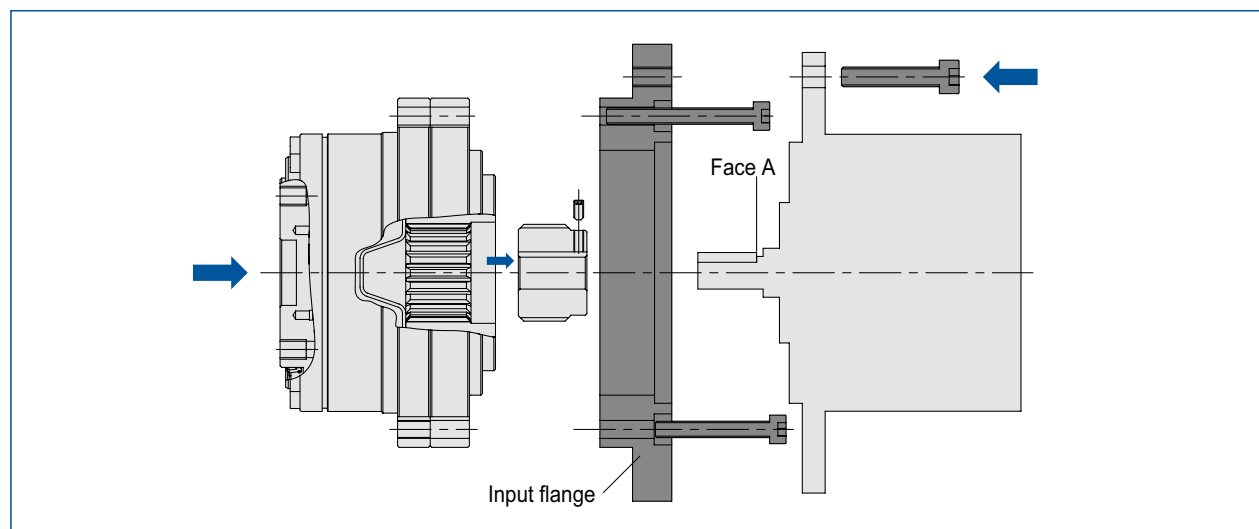

# Ultra-Flat Gear Unit CSD-2UH Series



Available in 7 sizes with ratios 50:1 to 160:1, CSD-2UH is an ultra-thin and compact housed gear component unit.

- Zero Backlash
- Lightweight
- Ultra-flat
- Compact and simple design

$L_{10}$  Life: 7,000 h

## • CSD-2UH Series Ratings

Item Size	Ratio	Rated Torque at 2000 rpm		Repeated Peak Torque		Maximum Momentary Torque	
		Nm	In-lb	Nm	In-lb	Nm	In-lb
14	50	3.7	33	12	106	24	212
	100	5.4	48	19	168	35	310
17	50	11	97	23	204	48	425
	100	16	142	37	327	71	628
20	50	17	150	39	345	69	611
	100	28	248	57	504	95	841
	160	28	248	64	566	95	841
25	50	27	239	69	611	127	1124
	100	47	416	110	974	184	1628
	160	47	416	123	1089	204	1805
32	50	53	469	151	1336	268	2372
	100	96	850	233	2062	420	3717
	160	96	850	261	2310	445	3938
40	50	96	850	281	2487	480	4248
	100	185	1637	398	3522	700	6195
	160	206	1823	453	4009	765	6770
50	50	172	1522	200	1770	1000	8850
	100	329	2912	686	6071	1440	12744
	160	370	3275	823	7284	1715	15178

## • Cross Roller Bearing Specification

Item Size	Basic Rated Load				Permissible Moment Load Mc		Moment Stiffness Km	
	Basic Dynamic Rated Load C		Basic Static Rated Load Co		Nm	In-lb	x10 <sup>4</sup> Nm/rad	In-lb/arc.min
	x10 <sup>3</sup> N	lb	x10 <sup>3</sup> N	lb				
14	47	1057	60.7	1365	41	363	3.48	90
17	52.9	1189	75.5	1697	64	566	7.75	200
20	57.8	1299	90	2023	91	805	12.8	330
25	96	2158	151	3394	156	1381	24.2	623
32	150	3372	250	5620	313	2770	53.9	1388
40	213	4788	365	8205	450	3983	91	2343
50	348	7823	602	13533	759	6717	171	4403

## • Dimensions

Unit: mm

Size	14	17	20	25	32	40	50
Symbol							
øA h7	55	62	70	85	112	126	157
B	25	26.5	29.5	37.1	43	51.7	62.5

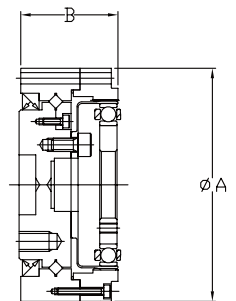
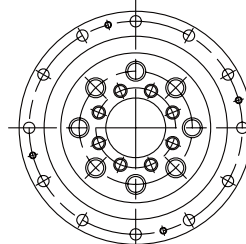

# CSD-2UF Series



Available in 6 sizes with ratios 50:1 to 160:1, CSD-2UF is an ultra-thin and compact housed gear component unit with a hollow through bore.

- Zero Backlash
- Hollow shaft
- High load capacity
- Lightweight
- Ultra-flat
- Compact and simple design

L<sub>10</sub> Life: 7,000h

## •CSD-2UF Series Ratings

Item Size	Ratio	Rated Torque at 2000 rpm		Repeated Peak Torque		Maximum Momentary Torque	
		Nm	In-lb	Nm	In-lb	Nm	In-lb
14	50	3.7	33	12	106	24	212
	100	5.4	48	19	168	35	310
17	50	11	97	23	204	48	425
	100	16	142	37	327	71	628
20	50	17	150	39	345	69	611
	100	28	248	57	504	95	841
	160	28	248	64	566	95	841
25	50	27	239	69	611	127	1124
	100	47	416	110	974	184	1628
	160	47	416	123	1089	204	1805
32	50	53	469	151	1336	268	2372
	100	96	850	233	2062	420	3717
	160	96	850	261	2310	445	3938
40	50	96	850	281	2487	480	4248
	100	185	1637	398	3522	700	6195
	160	206	1823	453	4009	765	6770

## • Cross Roller Bearing Specification

Item Size	Basic Rated Load				Permissible Moment Load Mc		Moment Stiffness Km	
	Basic Dynamic Rated Load C		Basic Static Rated Load Co		Nm	In-lb	Moment Stiffness Km	
	x10 <sup>3</sup> N	lb	x10 <sup>3</sup> N	lb			x10 <sup>4</sup> Nm/rad	In-lb/arc.min
14	57.8	1299	90	2023	91	805	12.8	330
17	104	2338	163	3664	124	1097	15.4	397
20	146	3282	220	4946	187	1655	25.2	649
25	218	4901	358	8048	258	2283	39.2	1009
32	382	8587	654	14702	580	5133	100	2575
40	433	9734	816	18344	849	7514	179	4609

## •Dimensions

Unit: mm

Size	14	17	20	25	32	40
Symbol						
øA h7	70	80	90	110	142	170
B	22	22.7	26.8	31.5	37	45

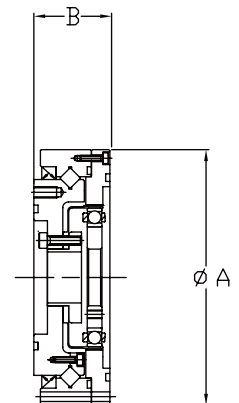
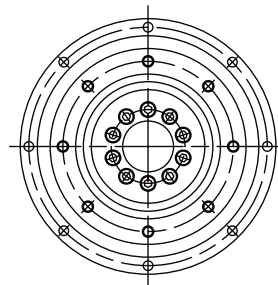

# Compact Gearhead/Double Shaft CSF Mini Series Unit



CSF-1U

CSF-2XH

CSF mini gearheads provide high positioning accuracy in a super-compact package. Compact 4-point contact ball bearing is mounted in the main shaft. Available in five sizes and four ratios, the CSF mini gearheads feature shaft or flange outputs.

- Zero backlash
- high positioning accuracy
- Compact and lightweight
- High torque capacity
- High radial, axial, and moment load capacity
- 4 point contact bearing
- Ratios: 30:1 to 100:1
- Flange output, shaft output, shaft input and output

**L<sub>10</sub> Life: 7,000 h**

## •CSF Mini Series Ratings

Item	Reduction Ratio	Rated Torque at 2000 rpm		Limit for Repeated Peak Torque		Limit for Momentary Peak Torque	
		Nm	In-lb	Nm	In-lb	Nm	In-lb
3	30	0.06	0.53	0.13	1.15	0.22	1.95
	50	0.11	0.97	0.21	1.86	0.41	3.63
	100	0.16	1.42	0.3	2.66	0.57	5.04
5	30	0.25	2.2	0.5	4.4	0.9	8.0
	50	0.4	3.5	0.9	8.0	1.8	16
	100	0.6	5.3	1.4	12.4	2.7	24
8	30	0.9	8.0	1.8	16	3.3	29
	50	1.8	16	3.3	29	6.6	58
	100	2.4	21	4.8	42	9	80
11	30	2.2	19	4.5	40	8.5	75
	50	3.5	31	8.3	73	17	150
	100	5	44	11	97	25	221
14	30	4	35	9	80	17	150
	50	5.4	48	18	159	35	310
	80	7.8	69	23	204	47	416
	100	7.8	69	28	248	54	478

## •4 Point Contact Bearing Specification

Item	Basic Rated Load				Permissible Moment Load Mc		Moment Stiffness Km	
	Basic Dynamic Rated Load C		Basic Static Rated Load Co		Nm	In-lb	Nm/rad	In-lb/arc.min
	x10 <sup>2</sup> N	lb	x10 <sup>2</sup> N	lb				
3	6.65	149	4.24	95	0.27	2	0.9x10 <sup>2</sup>	0.2
5	9.14	205	7.63	172	0.89	8	7.41x10 <sup>2</sup>	1.9
8	21.6	486	19.0	427	3.46	31	2.76x10 <sup>3</sup>	1.7
11	38.9	874	35.4	796	6.6	58	7.41x10 <sup>3</sup>	19.0
14	61.2	1376	58.5	1315	13.2	117	1.34x10 <sup>4</sup>	34.5

## •Dimensions

Unit: mm

Size	3	5	8	11	14
Symbol					
øA	17.5	29	43.5	58	73
B	20.5	17	28.7	38.3	45
C	13	22	32	43	53

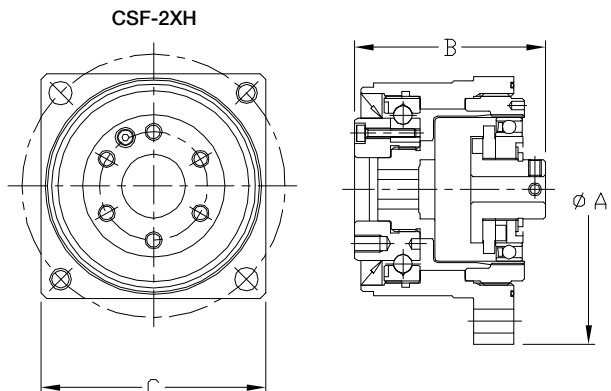



# Ultra-Flat Compact Gearhead CSF Mini Series Unit



The CSF-2UP gear units have an ultra-flat configuration with high-moment stiffness. The new models are lightweight and extremely flat. Thanks to a cross roller bearing used at the output flange, the CSF-2UP gearheads offer high-moment stiffness.

- Zero backlash
- high positioning accuracy
- Compact and lightweight
- High torque capacity
- High radial, axial, and moment load capacity
- Cross roller bearing
- Ratios: 30:1 to 100:1

$L_{10}$  Life: 7,000 h

## •CSF Mini Series Ratings

Item Size	Reduction Ratio	Rated Torque at 2000 rpm		Limit for Repeated Peak Torque		Limit for Momentary Peak Torque	
		Nm	In-lb	Nm	In-lb	Nm	In-lb
8	30	0.9	8.0	1.8	16	3.3	29
	50	1.8	16	3.3	29	6.6	58
	100	2.4	21	4.8	42	9	80
11	30	2.2	19	4.5	40	8.5	75
	50	3.5	31	8.3	73	17	150
	100	5	44	11	97	25	221
14	30	4	35	9	80	17	150
	50	5.4	48	18	159	35	310
	80	7.8	69	23	204	47	416
	100	7.8	69	28	248	54	478

## •Cross Roller Bearing Specification

Item Size	Basic Rated Load				Permissible Moment Load $M_c$		Moment Stiffness $K_m$	
	Basic Dynamic Rated Load C		Basic Static Rated Load $C_0$		Nm	In-lb	Nm/rad	In-lb/arc.min
	$\times 10^3 N$	lb	$\times 10^3 N$	lb				
8	21.6	486	19.0	427	3.46	31	$2.76 \times 10^3$	1.7
11	38.9	874	35.4	796	6.6	58	$7.41 \times 10^3$	19.0
14	61.2	1376	58.5	1315	13.2	117	$1.34 \times 10^4$	34.5

## •Dimensions

Unit: mm

Size	8	11	14
Symbol			
$\phi A$	66	80	100
B	24.8	27	33.5
P	$50 \pm 1$	$60 \pm 1$	$75 \pm 1$

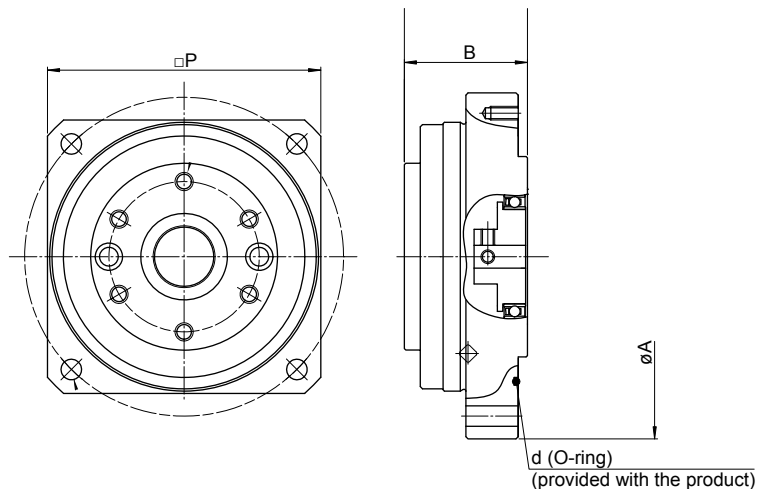

## Gear unit with hollow shaft or solid input shaft

## SHF-2UH Series



Incorporating a Harmonic Drive® gear component into an integral housing, the SHF-2UH is a compact hollow shaft gearhead with zero backlash.

- Zero backlash
- Large hollow thru bore
- High positioning accuracy
- Compact and simple design
- High torque capacity
- High torsional stiffness
- Shaft input units available (SHF-2UJ)

$L_{10}$  Life: 7,000h

## •SHF Series Ratings

Item	Reduction Ratio	Rated Torque at 2000rpm		Limit for Repeated Peak Torque		Limit for Momentary Peak Torque	
		Nm	In-lb	Nm	In-lb	Nm	In-lb
11	50	3.5	31	8.3	73	17	150
	100	5	44	11	97	25	221
14	30	4.0	35	9.0	80	17	150
	50	5.4	48	18	159	35	310
	80	7.8	69	23	204	47	416
	100	7.8	69	28	248	54	478
17	30	8.8	78	6	142	30	266
	50	16	142	34	301	70	620
	80	22	195	43	381	87	770
	100	24	212	54	478	110	974
20	120	24	212	54	478	86	761
	30	15	133	27	239	50	443
	50	25	221	56	496	98	867
	80	34	301	74	655	127	1124
25	100	40	354	82	726	147	1301
	120	40	354	87	770	147	1301
	160	40	354	92	814	147	1301
	30	27	239	50	443	95	841
32	50	39	345	98	867	186	1646
	80	63	558	137	1212	255	2257
	100	67	593	157	1389	284	2514
	120	67	593	167	1478	304	2691
40	160	67	593	176	1558	314	2779
	30	54	478	100	885	200	1770
	50	76	673	216	1912	382	3381
	80	118	1044	230	2036	568	5027
45	100	137	1212	333	2947	647	5726
	120	137	1212	353	3124	686	6072
	160	137	1212	372	3292	686	6072

Item	Reduction Ratio	Rated Torque at 2000rpm		Limit for Repeated Peak Torque		Limit for Momentary Peak Torque	
		Nm	In-lb	Nm	In-lb	Nm	In-lb
40	50	137	1212	402	3558	686	6072
	80	206	1823	519	4593	980	8674
	100	265	2345	568	5027	1080	9559
	120	294	2602	617	5460	1180	10444
45	160	294	2602	647	5726	1180	10444
	50	176	1558	500	4425	950	8408
	80	313	2770	706	6248	1270	11240
	100	353	3124	755	6682	1570	13896
50	120	402	3558	823	7284	1760	15577
	160	402	3558	882	7806	1910	16905
	50	245	2168	715	6328	1430	12657
	80	372	3292	941	8328	1860	16462
58	100	470	4160	980	8673	2060	18233
	120	529	4682	1080	9558	2060	18233
	160	529	4682	1180	10443	2450	21684
	80	353	3124	1020	9027	1960	17347
58	50	549	4859	1480	13098	2450	21684
	100	686	6160	1590	14072	3180	28145
	120	745	6593	1720	15222	3330	29473
	160	745	6593	1840	16284	3430	30358

## •Cross Roller Bearing Specification

Item	Basic Rated Load				Permissible Moment Load Mc		Moment Stiffness Km	
	Basic Dynamic Rated Load C		Basic Static Rated Load Co		Nm	In-lb	x 10 <sup>4</sup> Nm /rad	In-lb/arc-min
	x 10 <sup>2</sup> N	lb	x 10 <sup>2</sup> N	lb				
11	52.9	1189	75.5	1697	74	655	6.5	167
14	58	1304	86	1933	74	655	8.5	219
17	104	2338	163	3664	124	1097	15.1	389
20	146	3282	220	4946	187	1655	25.2	649
25	218	4901	358	8048	258	2283	39.2	1009
32	382	8587	654	14702	580	5133	100	2575
40	433	9734	816	18344	849	7514	179	4609
45	776	17444	1350	30348	1127	9974	257	6618
50	816	18344	1490	33495	1487	13160	351	9038
58	874	19648	1710	38441	2180	19293	531	13673

- "Basic dynamic rated load" is a constant stationary radial load that achieves a basic dynamic rated life of the bearing of one million revolutions. "Basic static rated load" is a static load that achieves a contact stress of a constant level (408kN/mm<sup>2</sup>) at the center of a contact zone between the rolling element receiving a maximum load and track.

## •Dimensions

Unit: mm

Size	11	14	17	20	25	32	40	45	50	58
Symbol										
øA	45.3	54	64	75	90	115	140	160	172	201
B	48	52.5	56.5	51.5	55.5	65.5	79	85	93	106

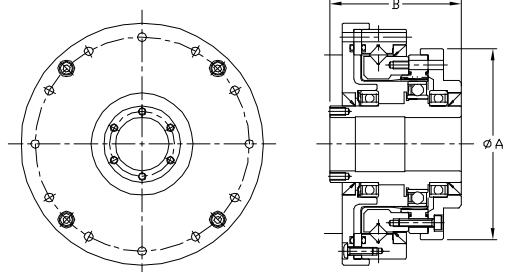

# SHF-2UH-LW Series

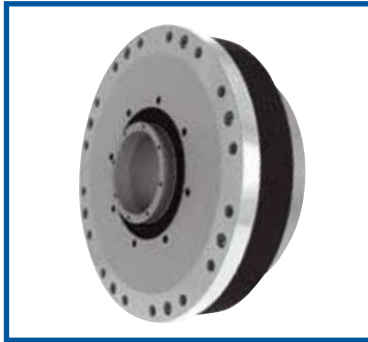

LW indicates lightweight. Incorporating a Harmonic Drive® gear component into an integral housing, the SHF-2UH-LW is a lightweight compact hollow shaft gearhead with zero backlash.

- Zero backlash
- 20% lighter than standard unit
- Large hollow through bore
- High positioning accuracy
- High torque capacity
- High torsional stiffness

$L_{10}$  Life: 7,000 h

## •SHF-LW Series Ratings

Item Size	Gear Ratio	Rated Torque at 2000rpm		Limit for Repeated Peak Torque		Limit for Momentary Torque	
		Nm	In-lb	Nm	In-lb	Nm	In-lb
14	30	4.0	35	9.0	80	17	150
	50	5.4	48	18	159	35	310
	80	7.8	69	23	204	47	416
	100	7.8	69	28	248	54	478
17	30	8.8	78	16	142	30	266
	50	16	142	34	301	70	620
	80	22	195	43	381	87	770
	100	24	212	54	478	108	956
20	120	24	212	54	478	86	761
	30	15	133	27	239	50	443
	50	25	221	56	496	98	867
	80	34	301	74	655	127	1,124
25	100	40	354	82	726	147	1,301
	120	40	354	87	770	147	1,301
	160	40	354	92	814	147	1,301
	30	27	239	50	443	95	841
32	50	39	345	98	867	186	1,646
	80	63	558	137	1,213	255	2,257
	100	67	593	157	1,390	284	2,514
	120	67	593	167	1,478	304	2,691
40	160	67	593	176	1,558	314	2,779
	30	54	478	100	885	200	1,770
	50	76	673	216	1,912	382	3,381
	80	118	1,044	304	2,691	568	5,027
50	100	137	1,213	333	2,947	647	5,726
	120	137	1,213	353	3,124	686	6,072
	160	137	1,213	372	3,292	686	6,072

Item Size	Gear Ratio	Rated Torque at 2000rpm		Limit for Repeated Peak Torque		Limit for Momentary Torque	
		Nm	In-lb	Nm	In-lb	Nm	In-lb
40	50	137	1,213	402	3,558	686	6,072
	80	206	1,823	519	4,594	980	8,674
	100	265	2,345	568	5,027	1,080	9,559
	120	294	2,602	617	5,461	1,180	10,444
45	160	294	2,602	647	5,726	1,180	10,444
	50	176	1,558	500	4,425	950	8,408
	80	313	2,770	706	6,249	1,270	11,240
	100	353	3,124	755	6,682	1,570	13,896
50	120	402	3,558	823	7,284	1,760	15,577
	160	402	3,558	882	7,806	1,910	16,905
	50	245	2,168	715	6,328	1,430	12,657
	80	372	3,292	941	8,329	1,860	16,462
58	100	470	4,160	980	8,674	2,060	18,233
	120	529	4,682	1,080	9,559	2,060	18,233
	160	529	4,682	1,180	10,444	2,450	21,684
	50	353	3,124	1,020	9,028	1,960	17,347
58	80	549	4,859	1,480	13,099	2,450	21,684
	100	696	6,160	1,590	14,073	3,180	28,145
	120	745	6,594	1,720	15,223	3,330	29,473
	160	745	6,594	1,840	16,285	3,430	30,358

## •Cross Roller Bearing Specification

Item Size	Basic Rated Load				Allowable Moment Load Mc		Moment Stiffness Km	
	Basic Dynamic Rated Load C		Basic Static Rated Load Co		Nm	In-lb	x 10 <sup>4</sup> Nm / rad	In-lb/arc-min
	x 10 <sup>3</sup> N	lb	x 10 <sup>3</sup> N	lb				
14	58	1,304	86	1,933	74	655	8.5	75
17	104	2,338	163	3,664	124	1,097	15.4	136
20	146	3,282	220	4,946	187	1,655	25.2	223
25	218	4,901	358	8,048	258	2,283	39.2	347
32	382	8,588	654	14,703	580	5,133	100	885
40	433	9,734	816	18,344	849	7,514	179	1,584
45	776	17,445	1,350	30,349	1,127	9,975	257	2,275
50	816	18,344	1,490	33,497	1,487	13,161	351	3,107
58	874	19,648	1,710	38,442	2,180	19,295	531	4,700

\*\*1: "Basic dynamic rated load" is a constant stationary radial load that achieves a basic dynamic rated life of the bearing of one million revolutions.

\*\*2: "Basic static rated load" is a static load that achieves a contact stress of a constant level (408kN/mm<sup>2</sup>) at the center of a contact zone between the rolling element receiving a maximum load and track.

## •Dimensions

Unit: mm

Size Symbol	14	17	20	25	32	40	45	50	58
øA	52	62	73	88	115	140	160	168	195
B	52.5	56.5	51.5	55.5	65.5	79	85	93	106

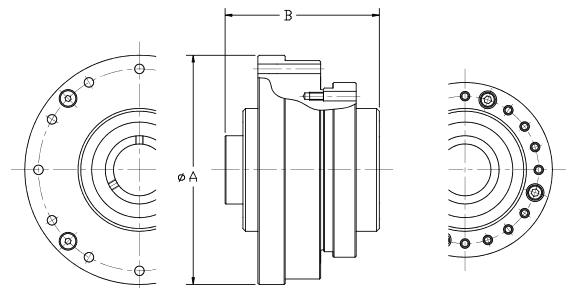

## High torque gear unit with hollow shaft or solid input shaft

## SHG-2UH Series



The SHG-2UH series with a hollow shaft is a high torque, compact, precision gearhead with zero backlash and exceptional accuracy and repeatability.

- Zero backlash
- Large hollow through bore
- High positioning accuracy
- High torque capacity
- High torsional stiffness
- Shaft input units available (SHG-2UJ)
- 30% increased torque compared to SHF Units

$L_{10}$  Life: 10,000 h

## •SHG Series Ratings

Item Size	Reduction Ratio	Rated Torque at 2000rpm		Limit for Repeated Peak Torque		Limit for Momentary Peak Torque	
		Nm	In-lb	Nm	In-lb	Nm	In-lb
14	50	7.0	62	23	204	46	407
	80	10	89	30	266	61	540
	100	10	89	36	319	70	620
17	50	21	186	44	389	91	805
	80	29	257	56	496	113	1000
	100	31	274	70	620	143	1266
20	120	31	274	70	620	112	991
	50	33	292	73	646	127	1124
	80	44	389	96	850	165	1460
25	100	52	460	107	947	191	1690
	120	52	460	113	1000	191	1690
	160	52	460	120	1062	191	1690
32	50	51	451	127	1124	242	2142
	80	82	726	178	1575	332	2938
	100	87	770	204	1805	369	3266
40	120	87	770	217	1920	395	3496
	160	87	770	229	2027	408	3611
	50	99	876	281	2487	497	4399
50	80	153	1354	395	3496	738	6532
	100	178	1575	433	3832	841	7443
	120	178	1575	459	4062	892	7895
58	160	178	1575	484	4283	892	7895

Item Size	Reduction Ratio	Rated Torque at 2000rpm		Limit for Repeated Peak Torque		Limit for Momentary Peak Torque	
		Nm	In-lb	Nm	In-lb	Nm	In-lb
40	50	178	1575	523	4629	892	7895
	80	268	2372	675	5974	1270	11240
	100	345	3053	738	6531	1400	12391
	120	382	3381	802	7098	1530	13542
45	160	382	3381	841	7443	1530	13542
	50	229	2027	650	5753	1235	10931
	80	407	3602	918	8124	1651	14613
	100	459	4062	982	8691	2041	18064
50	120	523	4629	1070	9470	2288	20250
	160	523	4629	1147	10151	2483	21976
	80	484	4283	1223	10824	2418	21401
	100	611	5407	1274	11275	2678	23702
55	120	688	6089	1404	12425	2678	23702
	160	688	6089	1534	13576	3185	28190
	80	714	6319	1924	17027	3185	28190
	100	905	8009	2067	18293	4134	36589
60	120	969	8576	2236	19789	4329	38315
	160	969	8576	2392	21169	4459	39465
	80	969	8576	2743	24276	4836	42802
	100	1236	10939	2990	26462	6175	54653
65	120	1236	10939	3263	28878	6175	54653
	160	1236	10939	3419	30258	6175	54653

## •Cross Roller Bearing Specification

Item Size	Basic Rated Load				Permissible Moment Load Mc		Moment Stiffness Km	
	Basic Dynamic Rated Load C		Basic Static Rated Load Co					
	x 10 <sup>2</sup> N	lb	x 10 <sup>2</sup> N	lb	Nm	In-lb	x 10 <sup>4</sup> Nm/rad	In-lb/arc-min
14	58	1304	86	1933	74	655	8.5	219
17	104	2338	163	3664	124	1097	15.1	389
20	146	3282	220	4946	187	1655	25.2	649
25	218	4901	358	8048	258	2283	39.2	1009
32	382	8587	654	14702	580	5133	100	2575
40	433	9734	816	18344	849	7514	179	4609
45	776	17444	1350	30348	1127	9974	257	6618
50	816	18344	1490	33495	1487	13160	351	9038
58	874	19648	1710	38441	2180	19293	531	13673
65	1300	29224	2230	50130	2740	24249	741	19081

- "Basic dynamic rated load" is a constant stationary radial load that achieves a basic dynamic rated life of the bearing of one million revolutions.
- "Basic static rated load" is a static load that achieves a contact stress of a constant level (408kN/mm<sup>2</sup>) at the center of a contact zone between the rolling element receiving a maximum load and track.

## •Dimensions

Unit: mm

Symbol	14	17	20	25	32	40	45	50	58	65
∅A	54	64	75	90	115	140	160	175	201	221
B	52.5	56.5	51.5	55.5	65.5	79	85	93	106	128

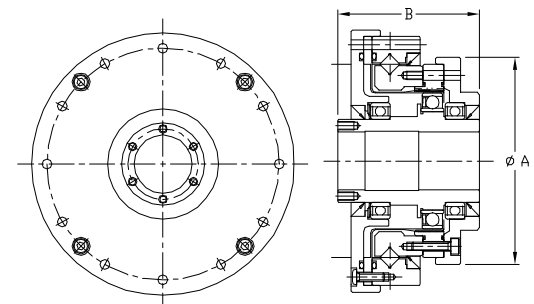

# SHG-2UH-LW Series

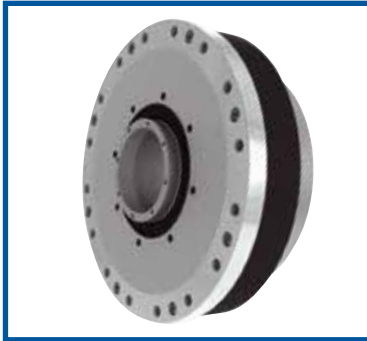

Incorporating a Harmonic Drive® gear component into an integral housing, the SHF-2UH-LW is a lightweight compact hollow shaft gearhead with zero backlash.

- Zero backlash
- 20% lighter than standard unit
- Large hollow through bore
- High positioning accuracy
- High torque capacity
- High torsional stiffness
- 30% increased torque compared to SHF Units

$L_{10}$  Life: 10,000 h

## •SHG-LW Series Ratings

Item	Gear Ratio	Rated Torque at 2000rpm		Limit for Repeated Peak Torque		Limit for Momentary Torque	
		Nm	In-lb	Nm	In-lb	Nm	In-lb
14	50	7	62	23	204	46	407
	80	10	89	30	266	61	540
	100	10	89	36	319	70	620
17	50	21	186	44	389	91	805
	80	29	257	56	496	113	1,000
	100	31	274	70	620	143	1,266
20	50	33	292	73	646	127	1,124
	80	44	389	96	850	165	1,460
	100	52	460	107	947	191	1,690
25	50	51	451	127	1,124	242	2,142
	80	82	726	178	1,575	332	2,938
	100	87	770	204	1,806	369	3,266
32	50	99	876	281	2,487	497	4,399
	80	153	1,354	395	3,496	738	6,532
	100	178	1,575	433	3,832	841	7,443

Item	Gear Ratio	Rated Torque at 2000rpm		Limit for Repeated Peak Torque		Limit for Momentary Torque	
		Nm	In-lb	Nm	In-lb	Nm	In-lb
40	50	178	1,575	523	4,629	892	7,895
	80	268	2,372	675	5,974	1,270	11,240
	100	345	3,054	738	6,532	1,400	12,391
45	50	229	2,027	650	5,753	1,235	10,931
	80	407	3,602	918	8,125	1,651	14,613
	100	459	4,062	982	8,691	2,041	18,064
50	50	229	2,027	650	5,753	1,235	10,931
	80	407	3,602	918	8,125	1,651	14,613
	100	459	4,062	982	8,691	2,041	18,064
58	50	229	2,027	650	5,753	1,235	10,931
	80	407	3,602	918	8,125	1,651	14,613
	100	459	4,062	982	8,691	2,041	18,064
65	50	229	2,027	650	5,753	1,235	10,931
	80	407	3,602	918	8,125	1,651	14,613
	100	459	4,062	982	8,691	2,041	18,064

## •Cross Roller Bearing Specification

Item	Basic Rated Load				Allowable Moment Load Mc		Moment Stiffness Km	
	Basic Dynamic Rated Load C		Basic Static Rated Load Co		Nm	In-lb	x 10 <sup>4</sup> Nm/rad	In-lb/arc-min
14	58	1,304	86	1,933	74	655	8.5	75
17	104	2,338	163	3,664	124	1,097	15.4	136
20	146	3,282	220	4,946	187	1,655	25.2	223
25	218	4,901	358	8,048	258	2,283	39.2	347
32	382	8,588	654	14,703	580	5,133	100	885
40	433	9,734	816	18,344	849	7,514	179	1,584
45	776	17,445	1,350	30,349	1,127	9,975	257	2,275
50	816	18,344	1,490	33,497	1,487	13,161	351	3,107
58	874	19,648	1,710	38,442	2,180	19,295	531	4,700
65	1,300	29,225	2,230	50,132	2,740	24,251	741	6,558

\*1: "Basic dynamic rated load" is a constant stationary radial load that achieves a basic dynamic rated life of the bearing of one million revolutions.

\*2: "Basic static rated load" is a static load that achieves a contact stress of a constant level (408kN/mm<sup>2</sup>) at the center of a contact zone between the rolling element receiving a maximum load and track.

## •Dimensions

Unit: mm

Size	14	17	20	25	32	40	45	50	58	65
Symbol										
øA	52	62	73	88	115	140	160	168	195	213
B	52.5	56.5	51.5	55.5	65.5	79	85	93	106	128

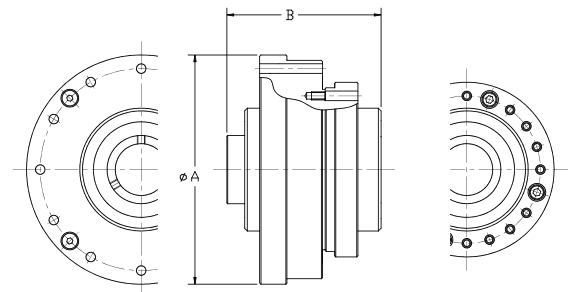

## Lightweight, Hollow Shaft

## SHD-2UH-LW Series

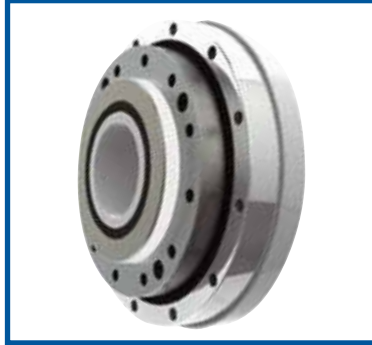

LW indicates lightweight. Axially compact, these gear units feature a large hollow input shaft and a robust cross roller bearing so loads can be mounted directly to the unit without the need for additional support bearings.

- Zero Backlash
- Ultra-flat design
- Large Hollow Input Shaft
- Accuracy <1 arc-min (most sizes)
- Rigid cross roller output bearing
- Lightweight

$L_{10}$  Life: 7,000 h

## •SHD-2UH-LW Series Ratings

Item Size	Ratio	Rated Torque at 2000 rpm		Limit for Repeated Peak Torque		Limit for Momentary Torque	
		Nm	In-lb	Nm	In-lb	Nm	In-lb
14	50	3.7	33	12	106	23	204
	100	5.4	48	19	168	35	310
17	50	11	97	23	204	48	425
	100	16	142	37	327	71	628
20	50	17	150	39	345	69	611
	100	28	248	57	504	95	841
	160	28	248	64	566	95	841
25	50	27	239	69	611	127	1,124
	100	47	416	110	974	184	1,629
	160	47	416	123	1,089	204	1,806
32	50	53	469	151	1,336	268	2,372
	100	96	850	233	2,062	420	3,717
	160	96	850	261	2,310	445	3,939
40	50	96	850	281	2,487	480	4,248
	100	185	1,637	398	3,523	700	6,196
	160	206	1,823	453	4,009	765	6,771

## • Cross Roller Bearing Specification

Item Size	Basic Rated Load				Allowable Moment Load Mc		Moment Stiffness Km	
	Basic Dynamic Rated Load C		Basic Static Rated Load Co		Nm	In-lb	$\times 10^4$ Nm/rad	In-lb/arc.min
	$\times 10^3$ N	lb	$\times 10^3$ N	lb				
14	29	652	43	967	37	327	7.08	63
17	52	1,169	81	1,821	62	549	12.7	112
20	73	1,641	110	2,473	93	823	21	186
25	109	2,450	179	4,024	129	1,142	31	274
32	191	4,294	327	7,351	290	2,567	82.1	727
40	216	4,856	408	9,172	424	3,753	145	1,283

\*\*1: "Basic dynamic rated load" is a constant stationary radial load that achieves a basic dynamic rated life of the bearing of one million revolutions.

\*\*2: "Basic static rated load" is a static load that achieves a contact stress of a constant level (408kN/mm<sup>2</sup>) at the center of a contact zone between the rolling element receiving a maximum load and track.

## •Dimensions

Unit: mm

Size	14	17	20	25	32	40
Symbol						
$\phi A$	74	84	95	115	147	175
B	45.5	48	42	46.5	55	65

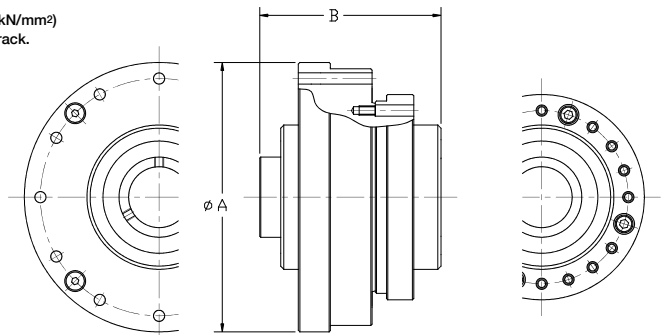



Hollow Shaft, Simplicity Unit  
**SHD-2SH Series**



Axially compact, these gear units feature a large hollow input shaft and a robust cross roller bearing so loads can be mounted directly to the unit without the need for additional support bearings.

- Zero backlash
- Extremely flat profile
- Hollow through bore
- High positioning accuracy
- High stiffness cross roller bearing output
- High radial, axial, and moment load capacity

$L_{10}$  Life: 7,000 h

•SHD Series Ratings

Size	Item	Reduction Ratio	Rated Torque at 2000 rpm		Limit for Repeated Peak Torque		Limit for Momentary Peak Torque	
			Nm	In-lb	Nm	In-lb	Nm	In-lb
14		50	3.7	33	12	106	23	204
		100	5.4	48	19	168	35	310
17		50	11	97	23	204	48	425
		100	16	142	37	327	71	628
20		50	17	150	39	345	69	611
		100	28	248	57	504	95	841
		160	28	248	64	566	95	841
25		50	27	239	69	611	127	1124
		100	47	416	110	974	184	1628
		160	47	416	123	1089	204	1806
32		50	53	469	151	1336	268	2372
		100	96	850	233	2062	420	3717
		160	96	850	261	2310	445	3939
40		50	96	850	281	2487	480	4248
		100	185	1637	398	3522	700	6196
		160	206	1823	453	4009	765	6771

•Cross Roller Bearing Specification

Size	Item	Basic Rated Load				Allowable Moment Load $M_c$		Moment Stiffness $K_m$	
		Basic Dynamic Rated Load C		Basic Static Rated Load $C_0$		Nm	In-lb	$\times 10^4$ Nm/rad	In-lb /arc-min
		$\times 10^3$ N	lb	$\times 10^3$ N	lb				
14		29	652	43	967	37	327	7.08	182
17		52	1169	81	1821	62	549	12.7	327
20		73	1641	110	2473	93	823	21	541
25		109	2450	179	4024	129	1142	31	798
32		191	4294	327	7351	290	2567	82.1	2114
40		216	4856	408	9172	424	3752	145	3734

• “Basic dynamic rated load” is a constant stationary radial load that achieves a basic dynamic rated life of the bearing of one million revolutions.  
 “Basic static rated load” is a static load that achieves a contact stress of a constant level (4kN/mm<sup>2</sup>) at the center of a contact zone between the rolling element receiving a maximum load and track.

•Dimensions

Unit: mm

Size	14	17	20	25	32	40
Symbol						
$\phi A$	70	80	90	110	142	170
B	17.5	18.5	19	22	27.9	33

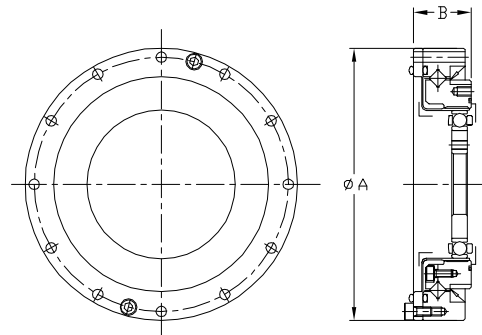



## Simplicity gear unit

## SHF-2SH/2SO Series



Simplicity Gear Units are Non-housed component gears combined with a precision cross roller output bearing. Simplicity Gear Units do not include the housing and output flange, which allows for even tighter integration into the customer's housing or machine structure.

- Zero backlash
- High positioning accuracy
- Compact and simple design
- High torque capacity
- High torsional stiffness

$L_{10}$  Life: 7,000h

## •SHF Series Ratings

Item Size	Reduction Ratio	Rated Torque at 2000rpm		Limit for Repeated Peak Torque		Limit for Momentary Peak Torque	
		Nm	In-lb	Nm	In-lb	Nm	In-lb
14	30	4.0	35	9.0	80	17	150
	50	5.4	48	18	159	35	310
	80	7.8	69	23	204	47	416
	100	7.8	69	28	248	54	478
17	30	8.8	78	6	142	30	266
	50	16	142	34	301	70	620
	80	22	195	43	381	87	770
	100	24	212	54	478	110	974
20	120	24	212	54	478	86	761
	30	15	133	27	239	50	443
	50	25	221	56	496	98	867
	80	34	301	74	655	127	1124
25	100	40	354	82	726	147	1301
	120	40	354	87	770	147	1301
	160	40	354	92	814	147	1301
	30	27	239	50	443	95	841
50	50	39	345	98	867	186	1646
	80	63	558	137	1212	255	2257
	100	67	593	157	1389	284	2514
	120	67	593	167	1478	304	2691
160	67	593	176	1558	314	2779	

Item Size	Reduction Ratio	Rated Torque at 2000rpm		Limit for Repeated Peak Torque		Limit for Momentary Peak Torque	
		Nm	In-lb	Nm	In-lb	Nm	In-lb
32	30	54	478	100	885	200	1770
	50	76	673	216	1912	382	3381
	80	118	1044	230	2036	568	5027
	100	137	1212	333	2947	647	5726
40	120	137	1212	353	3124	686	6072
	160	137	1212	372	3292	686	6072
	50	137	1212	402	3558	686	6072
	80	206	1823	519	4593	980	8674
45	100	265	2345	568	5027	1080	9559
	120	294	2602	617	5460	1180	10444
	160	294	2602	647	5726	1180	10444
	50	176	1558	500	4425	950	8408
50	80	313	2770	706	6248	1270	11240
	100	353	3124	755	6682	1570	13896
	120	402	3558	823	7284	1760	15577
	160	402	3558	882	7806	1910	16905
58	50	245	2168	715	6328	1430	12657
	80	372	3292	941	8328	1860	16462
	100	470	4160	980	8673	2060	18233
	120	529	4682	1080	9558	2060	18233
160	160	529	4682	1180	10443	2450	21684
	50	353	3124	1020	9027	1960	17347
	80	549	4859	1480	13098	2450	21684
	100	686	6160	1590	14072	3180	28145
180	120	745	6593	1720	15222	3330	29473
	160	745	6593	1840	16284	3430	30358

## •Cross Roller Bearing Specification

Item Size	Basic Rated Load				Allowable Moment Load Mc		Moment Stiffness Km	
	Basic Dynamic Rated Load C		Basic Static Rated Load Co		Nm	In-lb	x 10 <sup>3</sup> Nm/rad	In-lb/arc-min
	x 10 <sup>3</sup> N	lb	x 10 <sup>3</sup> N	lb				
14	58	1304	86	1933	74	655	8.5	219
17	104	2338	163	3664	124	1097	15.1	389
20	146	3282	220	4946	187	1655	25.2	649
25	218	4901	358	8048	258	2283	39.2	1009
32	382	8587	654	14702	580	5133	100	2575
40	433	9734	816	18344	849	7514	179	4609
45	776	17444	1350	30348	1127	9974	257	6618
50	816	18344	1490	33495	1487	13160	351	9038
58	874	19648	1710	38441	2180	19293	531	13673

- "Basic dynamic rated load" is a constant stationary radial load that achieves a basic dynamic rated life of the bearing of one million revolutions. "Basic static rated load" is a static load that achieves a contact stress of a constant level (408kN/mm<sup>2</sup>) at the center of a contact zone between the rolling element receiving a maximum load and track.

## •Dimensions (2SH)

Size Symbol	Unit: mm								
	14	17	20	25	32	40	45	50	58
øA	50	60	70	85	110	135	155	170	195
B	52.5	56.5	51.5	55.5	65.5	79	85	93	106

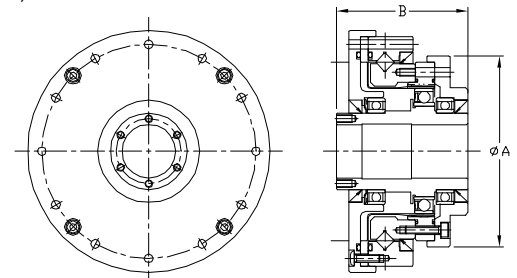

# High torque simplicity gear unit SHG-2SH/2SO Series



High Torque versions of our Simplicity Gear Units. Simplicity Gear Units do not include the housing and output flange, which allows for even tighter integration into the customer's housing or machine structure.

- Zero backlash
- High positioning accuracy
- High torque capacity
- High torsional stiffness
- 30% increased torque compared to SHF Units

$L_{10}$  Life: 10,000 h

## •SHG Series Ratings

Item	Reduction Ratio	Rated Torque at 2000rpm		Limit for Repeated Peak Torque		Limit for Momentary Peak Torque	
		Nm	In-lb	Nm	In-lb	Nm	In-lb
14	50	7.0	62	23	204	46	407
	80	10	89	30	266	61	540
	100	10	89	36	319	70	620
17	50	21	186	44	389	91	805
	80	29	257	56	496	113	1000
	100	31	274	70	620	143	1266
20	50	33	292	73	646	127	1124
	80	44	389	96	850	165	1460
	100	52	460	107	947	191	1690
25	50	51	451	127	1124	242	2142
	80	82	726	178	1575	332	2938
	100	87	770	204	1805	369	3266
32	50	99	876	281	2487	497	4399
	80	153	1354	395	3496	738	6532
	100	178	1575	433	3832	841	7443

Item	Reduction Ratio	Rated Torque at 2000rpm		Limit for Repeated Peak Torque		Limit for Momentary Peak Torque	
		Nm	In-lb	Nm	In-lb	Nm	In-lb
40	50	178	1575	523	4629	892	7895
	80	268	2372	675	5974	1270	11240
	100	345	3053	738	6531	1400	12391
	120	382	3381	802	7098	1530	13542
45	50	229	2027	650	5753	1235	10931
	80	407	3602	918	8124	1651	14613
	100	459	4062	982	8691	2041	18064
	120	523	4629	1070	9470	2288	20250
50	80	484	4283	1223	10824	2418	21401
	100	611	5407	1274	11275	2678	23702
	120	688	6089	1404	12425	2678	23702
58	80	714	6319	1924	17027	3185	28190
	100	905	8009	2067	18293	4134	36589
	120	969	8576	2236	19789	4329	38315
65	80	969	8576	2392	21169	4459	39465
	100	1236	10939	2990	26462	6175	54653
	120	1236	10939	3263	28878	6175	54653
	160	1236	10939	3419	30258	6175	54653

## •Cross Roller Bearing Specification

Item	Basic Rated Load				Allowable Moment Load Mc		Moment Stiffness Km	
	Basic Dynamic Rated Load C		Basic Static Rated Load Co		Nm	In-lb	x 10 <sup>4</sup> Nm /rad	In-lb/arc-min
	x 10 <sup>3</sup> N	lb	x 10 <sup>3</sup> N	lb				
14	58	1304	86	1933	74	655	8.5	219
17	104	2338	163	3664	124	1097	15.1	389
20	146	3282	220	4946	187	1655	25.2	649
25	218	4901	358	8048	258	2283	39.2	1009
32	382	8587	654	14702	580	5133	100	2575
40	433	9734	816	18344	849	7514	179	4609
45	776	17444	1350	30348	1127	9974	257	6618
50	816	18344	1490	33495	1487	13160	351	9038
58	874	19648	1710	38441	2180	19293	531	13673
65	1300	29224	2230	50130	2740	24249	741	19081

• "Basic dynamic rated load" is a constant stationary radial load that achieves a basic dynamic rated life of the bearing of one million revolutions.  
 "Basic static rated load" is a static load that achieves a contact stress of a constant level (408kN/mm<sup>2</sup>) at the center of a contact zone between the rolling element receiving a maximum load and track.

## •Dimensions (2SH)

Symbol	Size	14	17	20	25	32	40	45	50	58	65
	$\phi A$		50	60	70	85	110	135	155	175	195
B		52.5	56.5	51.5	55.5	65.5	79	85	93	106	128

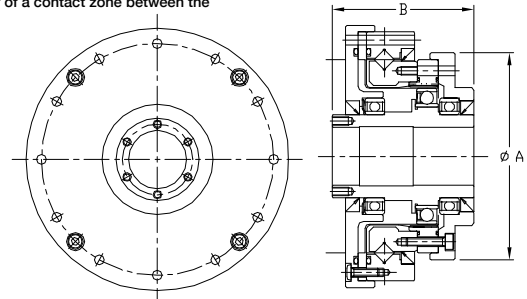

# Phasing Differential FD Series Component



The FD series is an extremely compact differential unit that allows you to fine-tune the phase and timing during operation.

- Pancake
- Ultra compact differential unit
- Backlash is very small and unit requires no assembly adjustment

## •FD Series Ratings

Size	Gear Ratio	Rotational Speed rpm									
		3500 rpm		2850 rpm		1450 rpm		960 rpm		500 rpm	
		Nm	In-lb	Nm	In-lb	Nm	In-lb	Nm	In-lb	Nm	In-lb
20	80	29	257	30	266	30	266	30	266	30	266
	100	30	266	31	274	36	319	36	319	36	319
	128	31	274	34	301	43	381	43	381	43	381
	160	32	283	35	310	45	398	49	434	49	434
25	80	46	407	50	443	57	504	57	504	57	504
	100	49	434	53	469	67	593	79	699	79	699
	120	52	460	55	487	70	620	82	726	96	850
	160	54	478	57	504	73	646	83	735	108	956
25	200	55	487	59	522	74	655	84	743	108	956
	78	98	867	108	956	108	656	108	956	108	956
	100	108	956	118	1044	147	1301	157	1389	157	1389
	131	108	956	118	1044	157	1389	176	1558	206	1823
32	157	108	956	118	1044	157	1389	176	1558	216	1912
	200	108	956	118	1044	157	1389	176	1558	216	1912
	260	108	956	118	1044	157	1389	176	1558	216	1912
	80	196	1735	196	1735	196	1735	196	1735	196	1735
40	100	235	2080	245	2168	265	2345	265	2345	265	2345
	128	235	2080	245	2168	314	2779	363	3213	372	3292
	160	235	2080	245	2168	314	2779	363	3213	451	3991
	200	235	2080	245	2168	314	2779	363	3213	451	3991
40	258	235	2080	245	2168	314	2779	363	3213	451	3991
	80	353	3124	353	3124	353	3124	353	3124	353	3124
	100	441	3903	470	4160	559	4947	559	4947	559	4947
	120	441	3903	470	4160	588	5204	666	5894	666	5894
50	160	441	3903	470	4160	588	5204	676	5983	843	7461
	200	441	3903	470	4160	588	5204	676	5983	843	7461
	242	441	3903	470	4160	588	5204	676	5983	843	7461
	78	-	-	-	-	764	6761	764	6761	764	6761
65	104	-	-	-	-	1100	9735	1190	10532	1190	10532
	132	-	-	-	-	1100	9735	1250	11063	1570	13895
	158	-	-	-	-	1100	9735	1250	11063	1570	13895
	208	-	-	-	-	1100	9735	1250	11063	1570	13895
65	260	-	-	-	-	1100	9735	1250	11063	1570	13895
	80	-	-	-	-	1370	12125	1370	12125	1370	12125
	96	-	-	-	-	1800	15930	1800	15930	1800	15930
	128	-	-	-	-	2180	19293	2490	22037	2710	23984
80	160	-	-	-	-	2180	19293	2490	22037	3130	27701
	194	-	-	-	-	2180	19293	2490	22037	3130	27701
	258	-	-	-	-	2180	19293	2490	22037	3130	27701
	320	-	-	-	-	2180	19293	2490	22037	3130	27701
100	80	-	-	-	-	2470	21860	2470	21860	2470	21860
	100	-	-	-	-	3720	32922	3720	32922	3720	32922
	120	-	-	-	-	3980	35223	4560	40356	4740	41949
	160	-	-	-	-	3980	35223	4560	40356	5720	50622
100	200	-	-	-	-	3980	35223	4560	40356	5720	50622
	242	-	-	-	-	3980	35223	4560	40356	5720	50622
	320	-	-	-	-	3980	35223	4560	40356	5720	50622

## •Dimensions

Unit: mm

Size	20	25	32	40	50	65	80	100
Symbol								
øA	70	85	110	135	170	215	265	330
B	25	29	37	43	53	71	83	101

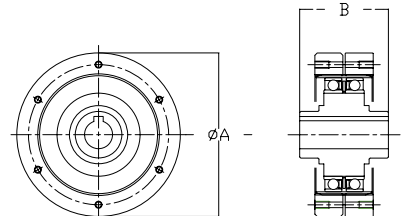

# FD Series Unit Type



The FD series is an extremely compact differential unit that allows you to fine-tune the phase and timing during operation. The unit type is provided with the housing so additional gears or pulleys required for the machine can be directly mounted onto it.

- Pancake
- Ultra compact differential unit
- Backlash is very small and unit requires no assembly adjustment

## •FD Series Ratings

Size	Gear Ratio	Rotational Speed rpm									
		3500 RPM		2850 RPM		1450 RPM		960 RPM		500 RPM	
		Nm	In-lb	Nm	In-lb	Nm	In-lb	Nm	In-lb	Nm	In-lb
20	80	29	257	30	266	30	266	30	266	30	266
	100	30	266	31	274	36	319	36	319	36	319
	128	31	274	34	301	43	381	43	381	43	381
	160	32	283	35	310	45	398	49	434	49	434
25	80	46	407	50	443	57	504	57	504	57	504
	100	49	434	53	469	67	593	79	699	79	699
	120	52	460	55	487	70	620	82	726	96	850
	160	54	478	57	504	73	646	83	735	108	956
25	200	55	487	59	522	74	655	84	743	108	956
	78	98	867	108	956	108	656	108	956	108	956
	100	108	956	118	1044	147	1301	157	1389	157	1389
	131	108	956	118	1044	157	1389	176	1558	206	1823
32	157	108	956	118	1044	157	1389	176	1558	216	1912
	200	108	956	118	1044	157	1389	176	1558	216	1912
	260	108	956	118	1044	157	1389	176	1558	216	1912
	80	196	1735	196	1735	196	1735	196	1735	196	1735
40	100	235	2080	245	2168	265	2345	265	2345	265	2345
	128	235	2080	245	2168	314	2779	363	3213	372	3292
	160	235	2080	245	2168	314	2779	363	3213	451	3991
	200	235	2080	245	2168	314	2779	363	3213	451	3991
40	258	235	2080	245	2168	314	2779	363	3213	451	3991
	80	353	3124	353	3124	353	3124	353	3124	353	3124
	100	441	3903	470	4160	559	4947	559	4947	559	4947
	120	441	3903	470	4160	588	5204	666	5894	666	5894
50	160	441	3903	470	4160	588	5204	676	5983	843	7461
	200	441	3903	470	4160	588	5204	676	5983	843	7461
	242	441	3903	470	4160	588	5204	676	5983	843	7461
	78	-	-	-	-	764	6761	764	6761	764	6761
65	104	-	-	-	-	1100	9735	1190	10532	1190	10532
	132	-	-	-	-	1100	9735	1250	11063	1570	13895
	158	-	-	-	-	1100	9735	1250	11063	1570	13895
	208	-	-	-	-	1100	9735	1250	11063	1570	13895
65	260	-	-	-	-	1100	9735	1250	11063	1570	13895
	80	-	-	-	-	1370	12125	1370	12125	1370	12125
	96	-	-	-	-	1800	15930	1800	15930	1800	15930
	128	-	-	-	-	2180	19293	2490	22037	2710	23984
80	160	-	-	-	-	2180	19293	2490	22037	3130	27701
	194	-	-	-	-	2180	19293	2490	22037	3130	27701
	258	-	-	-	-	2180	19293	2490	22037	3130	27701
	320	-	-	-	-	2180	19293	2490	22037	3130	27701
100	80	-	-	-	-	2470	21860	2470	21860	2470	21860
	100	-	-	-	-	3720	32922	3720	32922	3720	32922
	120	-	-	-	-	3980	35223	4560	40356	4740	41949
	160	-	-	-	-	3980	35223	4560	40356	5720	50622
100	200	-	-	-	-	3980	35223	4560	40356	5720	50622
	242	-	-	-	-	3980	35223	4560	40356	5720	50622
	320	-	-	-	-	3980	35223	4560	40356	5720	50622

## •Dimensions

Unit: mm

Size	20	25	32	40	50	65	80	100
Symbol								
øA	85	95	120	145	185	235	290	360
B	73	81	95	113	132	147	178	212

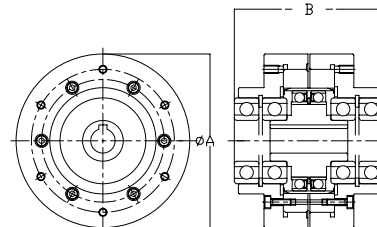

# Phasing Differential FBB Series

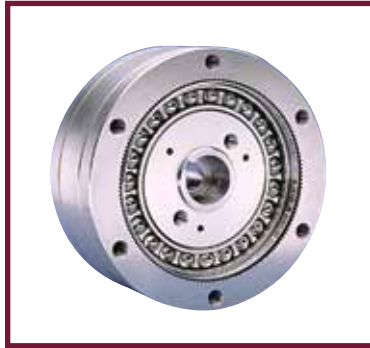

- 1:1 phasing differential between input and output
- High ratio trim adjustment
- Compact, low backlash design for end roll mounting

## •FBB Series Ratings

Size	Ratio	Limit for Repeated Peak Torque		Maximum Momentary Input rpm		Rated Output Torque									
						Input Speed									
						500 rpm		1000 rpm		1500 rpm		2000 rpm		3000 rpm	
In-lb	Nm	Oil	Grease	In-lb	Nm	In-lb	Nm	In-lb	Nm	In-lb	Nm	In-lb	Nm		
20	80	250	28	6000	3500	373.3	42	296	33	259	29	235	27	206	23
	100	300	34												
	120	350	40												
	160	390	44												
25	80	425	48	5000	3500	616.2	70	489	55	427	48	388	44	339	38
	100	600	68												
	120	700	79												
	160	780	88												
32	80	950	107	4500	3500	1229	139	976	110	853	96	775	88	677	76
	100	1200	136												
	120	1400	158												
	160	1550	175												
40	80	1700	192	4000	3000	2588	292	2054	232	1795	203	1631	184	1425	161
	100	2400	271												
	120	2700	305												
	160	3100	350												
50	80	3100	350	3500	2500	4826	545	3831	433	3347	378	3042	344	2658	300
	100	4200	475												
	120	5200	588												
	160	5800	655												

## •Dimensions

Size	No Load Starting Torque	No Load Starting Torque	Input Inertia	Input Inertia
	in-oz	Ncm	lb in <sup>2</sup>	kgcm <sup>2</sup>
20	4.5	3.2	0.049	0.143
25	6	4.2	0.124	0.363
32	8	5.7	0.45	1.32
40	27	19.1	1.17	3.42
50	50	35.3	3.39	9.91

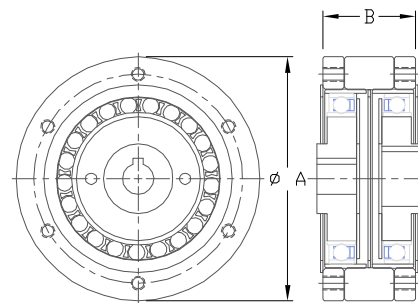

Unit: mm

Size	20	25	32	40	50
Symbol					
ø A	70	85	110	134	170
B	26.5	34.8	42	56.5	-

# HDI Infnit-Indexer® Phase Adjuster



- Fine tune rotational position of shafts and machine parts
- Phase cams
- Adjust roll registration
- Take up backlash in spur and worm gears
- Synchronize indexing devices

Infnit-Indexer® phase adjusters are available from immediate stock in the standard bore sizes shown with keyways, set screws, and tapped holes for face mounting of either hub. It is possible for the user to modify these configurations by disassembling the unit. The hub material is low carbon steel with suitable sizes shown in notes to the dimensional drawings. Additional sizes and configurations are available by special order.

## •3 Models, 6 Bore Sizes Available From Stock

HDI Size	Bore Size	O.D.	Length	Torque Capacity
-10	1/2" 5/8" 3/4"	2 3/8" (60.33mm)	1 1/16" (42.9mm)	1000 lb-in (113 Nm)
-25	3/4" 1"	3" (76.2mm)	2 3/16" (76.2mm)	2500 lb-in (283 Nm)
-50	1 1/4"	3 3/4" (95.3mm)	2 3/8" (95.3mm)	5000 lb-in (565 Nm)

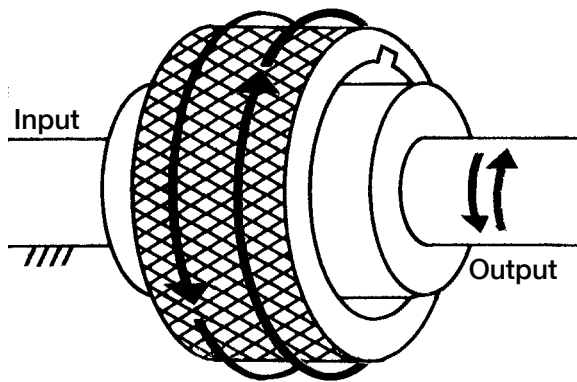

To operate, hand rotate the adjusting ring in either direction to produce a 100:1 reduction between the ring and the output. Adjust the friction adjustment/locking screw to desired resistance. For some applications, one adjustment will be sufficient for both shaft turning and phase adjusting modes. For more severe loading, such as hard stops or high peak torque situations, the friction adjustment/locking screw may be used to lock the adjusting ring in place to maintain phase.

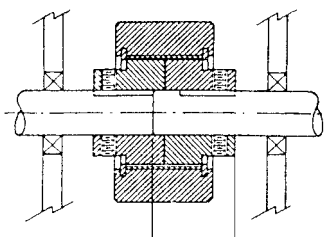

IN-LINE SHAFT

HDI Size	L DIM
-10	1.09
-25	1.34
-50	1.43

Flexible Couplings

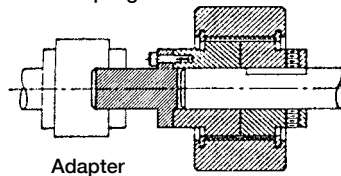

Adapter

IN-LINE SHAFT

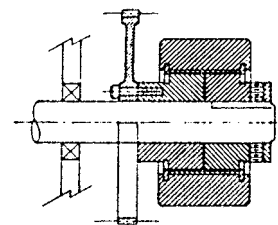

CONCENTRIC SHAFT

## •Dimensions

Unit : inch

Size	10	10	10	25	25	50
øA	2.38	2.38	2.38	3.00	3.00	3.75
B	1.69	1.69	1.69	2.19	2.19	2.37
øC	0.500	0.625	0.750	0.750	1.000	1.250
D	1.38	1.38	1.38	1.75	1.75	2.17

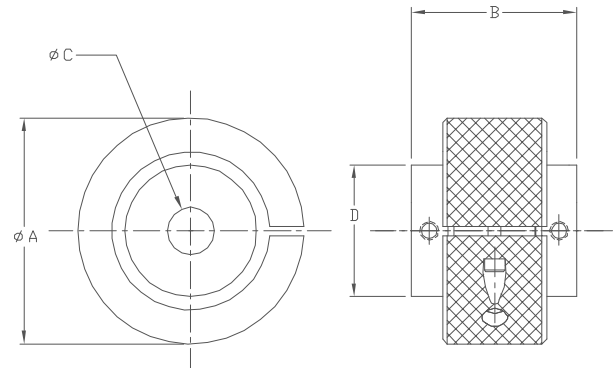



Quick Connect™ Gearhead for Servomotors

# CSF-GH Series

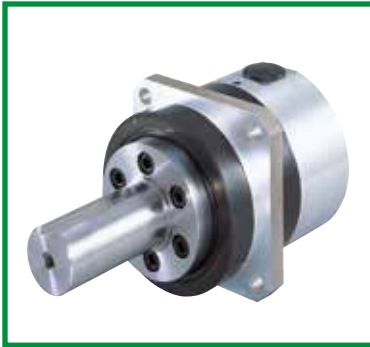

CSF-GH Quick Connect™ gearheads with zero-backlash Harmonic Drive® gearing are available with high reduction ratios, 50:1 to 160:1. CSF-GH utilizes our proprietary S tooth profile and provides high precision positioning (repeatability ±4 to ±10 arc-sec).

- Zero Backlash
- Available in 5 Sizes
- Peak torque 18Nm ~ 2630Nm
- Ratios, 50:1 to 160:1
- Accuracy <1 arc-min
- High Efficiency
- High load capacity output bearing
- Motor size range 30W to 5,000W

**L<sub>10</sub> Life: 7,000 h**

## •CSF-GH Series Ratings

Item Size	Reduction Ratio	Output Torque at 2000rpm		Limit for Repeated Peak Torque		Maximum Momentary Torque	
		Nm	In-lb	Nm	In-lb	Nm	In-lb
14	50	5.4	48	18	159	35	310
	80	7.8	69	23	204	47	416
	100	7.8	69	28	248	54	478
20	50	25	221	56	496	98	867
	80	34	301	74	655	127	1124
	100	40	354	82	726	147	1301
	120	40	354	87	770	147	1301
32	160	40	354	92	814	147	1301
	50	76	673	216	1912	382	3381
	80	118	1044	304	2690	568	5027
	100	137	1212	333	2947	647	5726
45	120	137	1212	353	3124	686	6071
	160	137	1212	372	3292	686	6071
	50	176	1558	500	4425	950	8408
	80	313	2770	706	6248	1270	11240
65	100	353	3124	755	6682	1570	13895
	120	402	3558	823	7284	1760	15576
	160	402	3558	882	7806	1910	16904
	80	745	6593	2110	18674	3720	32922
65	100	951	8416	2300	20355	4750	42038
	120	951	8416	2510	22214	4750	42038
	160	951	8416	2630	23276	4750	42038

## •Cross Roller Bearing Specification

Item Size	Basic Rated Load				Allowable Moment Load Mc		Moment Stiffness Km	
	Basic Dynamic Rated Load C		Basic Static Rated Load Co		Nm	In-lb	×10 <sup>4</sup> Nm/rad	In-lb/ arc.min
14	5110	1149	7060	1587	27	239	3.0	77
20	10600	2383	17300	3889	145	1283	17	438
32	20500	4608	32800	7373	258	2283	42	1082
45	41600	9352	76000	17085	797	7054	100	2575
65	81600	18344	149000	33495	2156	19082	323	8317

• "Basic dynamic rated load" is a constant stationary radial load that achieves a basic dynamic rated life of the bearing of one million revolutions.  
 "Basic static rated load" is a static load that achieves a contact stress of a constant level (4kN/mm<sup>2</sup>) at the center of a contact zone between the rolling element receiving a maximum load and track.

## •Dimensions

Unit: mm

Size Symbol	14	20	32	45	65
A	60	90	120	170	230
B	21	27	35	53	57
C (ref.)	55	72	105.5	128	157
D	37	53	98	103	135
øE	16	25	40	50	70

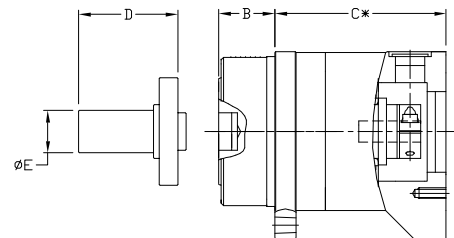
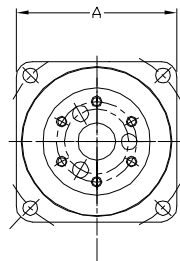

\* The length and shape of the motor adapter flange will depend upon the specific motor that is selected for use with the gearhead. Please contact Harmonic Drive LLC for a detailed drawing.



# CSG-GH Series



CSG-GH high-torque Quick Connect™ gearheads with zero backlash Harmonic Drive® gearing are available with high reduction ratios, 50:1 to 160:1.

- Zero Backlash
- Available in 5 Sizes
- Peak torque 23Nm – 3419Nm
- Ratios, 50:1 to 160:1
- Repeatability as low as 4 arc-seconds
- Accuracy <1 arc-min
- High Efficiency
- High load capacity output bearing
- Motor size range 30W to 5,000W
- 30% higher rated torque, repeated peak torque & maximum momentary torque than CSF series products of the same size

**L<sub>10</sub> Life: 10,000 h**

## •CSG-GH Series Ratings

Item Size	Gear Ratio	Rated Torque at 2000rpm		Limit for Repeated Peak Torque		Limit for Momentary Torque	
		Nm	In-lb	Nm	In-lb	Nm	In-lb
14	50	7.0	62	23	204	46	407
	80	10	89	30	266	61	540
	100	10	89	36	319	70	620
20	50	33	292	73	646	127	1124
	80	44	389	96	850	165	1460
	100	52	460	107	947	191	1690
	120	52	460	113	1000	191	1690
32	160	52	460	120	1062	191	1690
	50	99	876	281	2487	497	4399
	80	153	1354	395	3496	738	6532
	100	178	1575	433	3832	812	7187
45	120	178	1575	459	4062	812	7187
	160	178	1575	484	4284	812	7187
	50	229	2027	650	5753	1235	10931
	80	407	3602	918	8125	1651	14613
65	100	459	4062	982	8691	2033	17994
	120	523	4629	1070	9470	2033	17994
	160	523	4629	1147	10152	2033	17994
	80	969	8576	2743	24278	4836	42802
65	100	1236	10940	2990	26464	5174	45794
	120	1236	10940	3263	28880	5174	45794
	160	1236	10940	3419	30261	5174	45794

## •Cross Roller Bearing Specification

Item Size	Basic Rated Load				Allowable Moment Load Mc		Moment Stiffness Km	
	Basic Dynamic Rated Load C		Basic Static Rated Load Co		Nm	In-lb	×10 <sup>4</sup> Nm/rad	In-lb/ arc.min
	N	lb	N	lb				
14	5110	1149	7060	1587	27	239	3.0	77
20	10600	2383	17300	3889	145	1283	17	438
32	20500	4608	32800	7373	258	2283	42	1082
45	41600	9352	76000	17085	797	7054	100	2575
65	81600	18344	149000	33495	2156	19082	323	8317

• “Basic dynamic rated load” is a constant stationary radial load that achieves a basic dynamic rated life of the bearing of one million revolutions.  
 “Basic static rated load” is a static load that achieves a contact stress of a constant level (4kN/mm<sup>2</sup>) at the center of a contact zone between the rolling element receiving a maximum load and track.

## •Dimensions

Unit: mm

Size	14	20	32	45	65
Symbol					
A	60	90	120	170	230
B	21	27	35	53	57
C (ref.)	55	72	105.5	128	157
D	37	53	98	103	135
øE	16	25	40	50	70

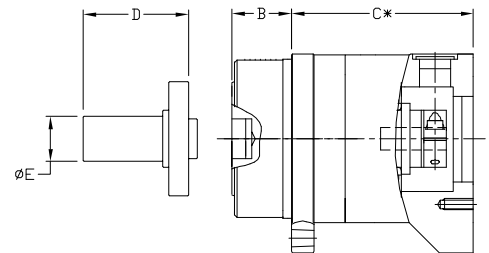
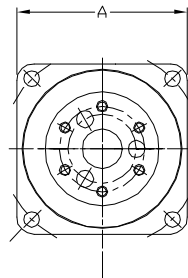

\* The length and shape of the motor adapter flange will depend upon the specific motor that is selected for use with the gearhead. Please contact Harmonic Drive LLC for a detailed drawing.

**Harmonic Planetary® Gearhead  
Quick Connect™ Coupling  
HPG Series**



Quick Connect™ gearhead for high performance servo motors. Reduction ratios 3:1 to 50:1. Available with flange output, straight shaft (without key), straight shaft (with key) and center tapped hole.

- Low backlash: Less than 3 arc-min (less than 1 arc-min optional)
- Ratios, 3:1 to 50:1
- Quick Connect™ coupling
- Peak torque 5Nm ~ 3200Nm
- High moment capacity cross roller output bearing
- High efficiency
- Sealed structure
- Motor size range 10W to 15,000W

**L<sub>10</sub> Life: 20,000 h**

**•HPG Series Ratings**

Size	Gear Ratio	Rated Torque at 3000 rpm		Repeated Peak Torque		Max. Momentary Peak Torque	
		Nm	In-lb	Nm	In-lb	Nm	In-lb
11	5	2.5	22	7.8	69	20	177
	9	2.5	22	3.9	35	20	177
	21	3.4	30	9.8	87	20	177
	37	3.4	30	9.8	87	20	177
	45	3.4	30	9.8	87	20	177
14	3	2.9	26	15	133	37	327
	5	5.9	52	23	204	56	496
	11	7.8	69	23	204	56	496
	15	9.0	80	23	204	56	496
	21	9	78	23	204	56	496
	33	10	89	23	204	56	496
20	3	8.8	78	64	566	124	1097
	5	16	142	100	885	217	1920
	11	20	177	100	885	217	1920
	15	24	212	100	885	217	1920
	21	25	221	100	885	217	1920
	33	29	257	100	885	217	1920

Size	Gear Ratio	Rated Torque at 3000 rpm		Repeated Peak Torque		Max. Momentary Peak Torque	
		Nm	In-lb	Nm	In-lb	Nm	In-lb
32	3	31	274	225	1991	507	4487
	5	66	584	300	2655	650	5753
	11	88	779	300	2655	650	5753
	15	92	814	300	2655	650	5753
	21	98	867	300	2655	650	5753
	33	108	956	300	2655	650	5753
50	3	97	858	657	5814	1850	16373
	5	170	1505	850	7523	1850	16373
	11	200	1770	850	7523	1850	16373
	15	230	2036	850	7523	1850	16373
	21	260	2301	850	7523	1850	16373
	33	270	2390	850	7523	1850	16373
65	4	500	4425	2200	19470	4500	39825
	5	530	4691	2200	19470	4500	39825
	12	600	5310	2200	19470	4500	39825
	15	730	6461	2200	19470	4500	39825
	20	800	7080	2200	19470	4500	39825
	25	850	7523	2200	19470	4500	39825
	40	640	5664	1900	16816	4500	39825
	50	750	6638	2200	19472	4500	39825

**•Cross Roller Bearing Specification**

Item	Basic Rated Load				Allowable Moment Load MC		Moment Stiffness Km	
	Basic Dynamic Rated Load C		Basic Static Rated Load Co		Nm	In-lb	x10 <sup>4</sup> Nm/rad	In-lb/arc-min
	N	lb	N	lb				
11	3116	700	4087	919	9.50	84	0.88	23
14	5110	1149	7060	1587	32.3	286	3.0	77
20	10600	2383	17300	3889	183	1620	16.8	433
32	20600	4631	32800	7373	452	4000	42.1	1084
50	41600	9352	76000	17085	1076	9523	100	2575
65	90600	20367	14800	33270	3900	34515	364	9373

**•Dimensions**

Unit: mm

Size	11	14	20	32	50	65
A	40	60	90	120	170	230
B	15	21	27	35	53	57
C (ref.)	30.5	64	71	104	123	184.5
D	27	37	53	98	103	-
øE	8	16	25	40	50	-

\*The length and shape of the motor adapter flange will depend upon the specific motor that is selected for use with the gearhead. Please contact Harmonic Drive LLC for a detailed drawing.

--- Size 65—Shaft is available as special request. ---

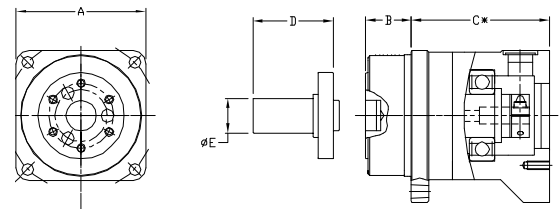

## HPG Helical Series



Quick Connect™ gearhead for high performance servo motors. Reduction ratios 3:1 to 10:1. Available with flange output, straight shaft (without key), straight shaft (with key) and center tapped hole.

- Helical Gearing
- Available in four Frame Sizes
- Peak Torque: 5Nm to 400Nm
- Ratios: 3,4,5,6,7,8,9 and 10:1
- High Efficiency
- Backlash <3 arc-min (<1arc-min available as an option)
- Repeatability ±20 arc-sec
- High load capacity Cross Roller output bearing
- Quick Connect™ coupling for easy mounting of any motor

L<sub>10</sub> Life: 20,000 h

### •HPG Helical Series Ratings

Size	Gear Ratio	Rated Torque at 3000 rpm		Repeated Peak Torque		Max. Momentary Peak Torque	
		Nm	In-lb	Nm	In-lb	Nm	In-lb
11	4	2.8	25	10	89	20	177
	5	2.9	26	10	89	20	177
	6	2.9	26	10	89	20	177
	7	3.1	27	9	80	20	177
	8	3.1	27	7	62	20	177
	9	3.1	27	6	53	20	177
	10	3.4	30	5	44	20	177
14	3	4.0	35	20	177	37	327
	4	7.0	62	30	266	56	496
	5	7.2	64	30	266	56	496
	6	7.3	65	30	266	56	496
	7	7.8	69	26	266	56	496
	8	7.8	69	20	177	56	496
	9	7.9	70	17	150	56	496
	10	8.5	75	15	133	56	496

Size	Gear Ratio	Rated Torque at 3000 rpm		Repeated Peak Torque		Max. Momentary Peak Torque		
		Nm	In-lb	Nm	In-lb	Nm	In-lb	
20	3	11	97	90	797	124	1097	
	4	23	203	133	1177	217	1921	
	5	23	203	133	1177	217	1921	
	6	23	203	126	1115	217	1921	
	7	25	221	108	956	217	1921	
	8	25	221	84	743	217	1921	
	9	25	221	73	646	217	1921	
	10	27	239	65	575	217	1921	
	32	3	50	443	290	2567	507	4487
		4	77	682	400	3540	650	5753
5		80	708	400	3540	650	5753	
6		80	708	390	3452	650	5753	
7		85	867	330	2921	650	5753	
8		85	752	260	2301	650	5753	
9		86	752	220	1947	650	5753	
10		92	814	200	1770	650	5753	

### •Cross Roller Bearing Specification

Size	Item	Basic Rated Load				Allowable Moment Load MC		Moment Stiffness Km	
		Basic Dynamic Rated Load C		Basic Static Rated Load Co		Nm	In-lb	x10 <sup>4</sup> Nm/rad	In-lb/arc-min
		N	lb	N	lb				
11		3116	700	4087	919	9.50	84	0.88	23
14		5110	1149	7060	1587	32.3	286	3.0	77
20		10600	2383	17300	3889	183	1620	16.8	433
32		20600	4631	32800	7373	452	4000	42.1	1084

### •Dimensions

Unit: mm

Size	11	14	20	32
A	40	60	90	120
B	15	21	27	35
C (ref.)	30.5	64	71	104
D	27	37	53	98
øE	8	16	25	40

\*The length and shape of the motor adapter flange will depend upon the specific motor that is selected for use with the gearhead. Please contact Harmonic Drive LLC for a detailed drawing.

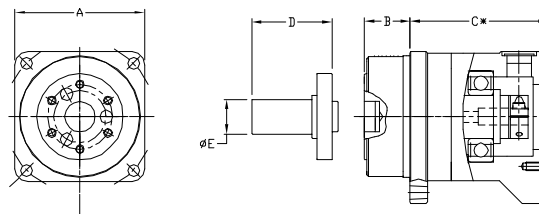

Harmonic Planetary® Gearhead  
Quick Connect™ Coupling

HPGP Series



High torque Quick Connect™ gearhead for high performance servo motors. Reduction ratios 3:1 to 50:1. Available with flange output, Straight shaft (without key), Straight shaft (with key) and center tapped hole.

- Peak torque 12Nm ~ 3940Nm
- High precision
- Backlash <1 arc-min is available (size #14-65) (Standard backlash specification is < 3 arc-min)
- Cross roller bearing for high load capacity and moment stiffness
- Quick Connect™ coupling
- Ratios, Single Stage: 4:1 to 5:1, Two Stage: 11:1 to 45:1
- Motor size range 10W to 15,000W

$L_{10}$  Life: 20,000h

•HPGP Series Ratings

Item Size	Gear Ratio	Rated Torque at 2000rpm		Limit for Repeated Peak Torque		Limit for Momentary Torque	
		Nm	In-lb	Nm	In-lb	Nm	In-lb
11	5	3.4	30	10	89	20	177
	21	4.6	41	13	115		
	37						
	45						
14	5	7.8	69	30	266	56	496
	11	10	89				
	15	12	106				
	21	12	106				
	33	13	115				
45	13	115					
20	5	21	186	133	1177	217	1921
	11	26	230				
	15	32	283				
	21	33	292				
	33	39	345				
45	39	345					

Item Size	Gear Ratio	Rated Torque at 2000rpm		Limit for Repeated Peak Torque		Limit for Momentary Torque	
		Nm	In-lb	Nm	In-lb	Nm	In-lb
32	5	87	770	400	3540	650	5753
	11	104	920				
	15	122	1080				
	21	130	1151				
	33	143	1266				
45	143	1266					
50	5	226	2000	1130	10001	1850	16374
	11	266	2354				
	15	306	2708				
	21	346	3062				
	33	359	3177				
45	359	3177					
65	4	665	5886	2920	25844	4500	39828
	5	705	6240				
	12	798	7063				
	15	971	8594				
	20	1060	9382				
	25	1130	10001				

•Cross Roller Bearing Specification

Item Size	Basic Rated Load				Allowable Moment Load MC		Moment Stiffness Km	
	Basic Dynamic Rated Load C		Basic Static Rated Load Co		Nm	In-lb	x10 <sup>4</sup> Nm/rad	In-lb/ arc-min
	N	lb	N	lb				
11	3116	700	4087	919	9.50	84	0.88	23
14	5110	1149	7060	1587	32.3	286	3.0	77
20	10600	2383	17300	3889	183	1620	16.8	433
32	20600	4631	32800	7373	452	4000	42.1	1084
50	41600	9352	76000	17085	1076	9523	100	2575
65	90600	20367	148000	33270	3900	34515	364	9373

•Dimensions

Unit: mm

Size	11	14	20	32	50	65
A	40	60	90	120	170	230
B	15	21	27	35	53	57
C (ref.)	30.5	64	71	104	123	184.5
D	27	37	53	98	103	-
øE	10	16	25	40	50	-

\*The length and shape of the motor adapter flange will depend upon the specific motor that is selected for use with the gearhead. Please contact Harmonic Drive LLC for a detailed drawing.

---- Size 65—Shaft is available as special request. ---

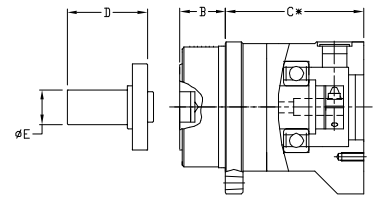
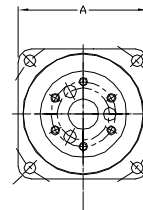

## HPG RA Series



Right angle, high precision, Harmonic Planetary® gearhead with low backlash.

- High precision Planetary gearhead
- Low backlash: Less than 3 arc-min (less than 1 arc-min optional)
- Quick Connect™ coupling
- High torque capacity
- High moment capacity cross roller output bearing
- Right angle configuration allows for use in limited space

L<sub>10</sub> Life: 20,000 h

### •HPG RA Series Ratings

Size	Ratio	Rated Torque		Max. Average Load Torque		Limit for Repeated Peak Torque		Max. Momentary Torque	
		Nm	In-lb	Nm	In-lb	Nm	In-lb	Nm	In-lb
32	5	66	584	150	1328	150	1328	650	5753
	11	88	779	170	1505	300	2655		
	15	92	814	170	1505				
	21	98	867	170	1505				
50	5	170	1505	340	3009	400	3540	1850	16373
	11	200	1770	400	3540	850	7523		
	15	230	2036	450	3983				
	21	260	2301	500	4425				
	33	270	2390	500	4425				
	45	270	2390	500	4425				
65	5	400	3540	400	3540	400	3540	4500	39825
	12	600	5310	960	8496	960	8496		
	15	730	6461	1200	10620	1200	10620		
	20	800	7080	1500	13275	1600	14160		
	25	850	7523	1500	13275	2000	17700		

### •Cross Roller Bearing Specification

Item Size	Basic Rated Load				Allowable Moment Load MC		Moment Stiffness Km	
	Basic Dynamic Rated Load C		Basic Static Rated Load Co		Nm	In-lb	x10 <sup>4</sup> Nm/rad	In-lb/ arc-min
	N	lb	N	lb				
32	20500	4608	32800	7373	452	4000	42.1	1084
50	41600	9352	76000	17085	1076	9523	100	2575
65	90600	20367	148000	33270	3900	34515	364	9373

### •Dimensions

Unit: mm

Size	A	øB	C	D	E*	F	G
32	120	115H7	35	107	140/175	175/197/217	130/180/220
50	170	165H7	53	144	168/200	209/234/254	130/180/220
65	230	220H8	57	226	168/200	291/316/336	130/180/220

\* Left side description: The limited length of the Motor shaft is 81mm.  
Right side description: The limited length of the Motor shaft is 116mm.

Note:  
Dimensions F & G depend on the chosen Motor flange square size.  
Contact Harmonic Drive LLC for special flange motor combination.

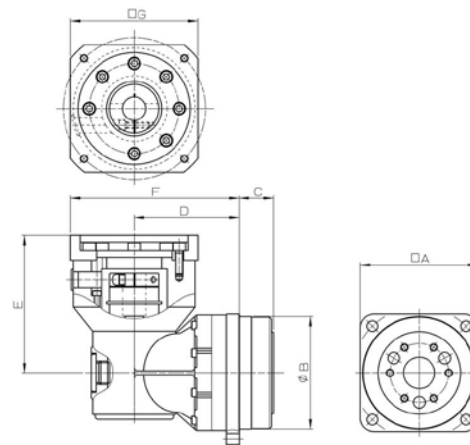

Harmonic Planetary® Gearhead  
Quick Connect™ Coupling

HPN Series



HPN value series planetary gearheads feature a robust design utilizing helical gears for quiet performance and long life. These gearheads are available with short lead times and are designed to couple to any servo motor with our Quick Connect™ coupling.

- Peak torque 9Nm to 752Nm
- Compact design
- High precision
- Backlash <5 arc-min (One stage) , < 7 arc-min (Two stage)
- Quick Connect™ coupling
- Reduction ratios between 3:1 and 31:1
- Helical gears for quiet performance
- Motor size range 30W to 7500W
- Quick delivery

L<sub>50</sub> Life: 20,000 h

•HPN Series Ratings

Size	Number of Stages	Gear Ratio	Rated Torque		Repeated Peak Torque		Momentary Peak Torque	
			Nm	In-lb	Nm	In-lb	Nm	In-lb
11	1	4	14	124	14	124	40	354
		5	14	124	16	142	40	354
		7	11	97	11	97	40	354
	2	10	9	80	9	80	40	354
		16	18	159	24	212	40	354
		20	22	195	24	212	40	354
14	1	3	22	195	25	221	89	788
		4	28	248	50	443	110	974
		5	29	257	50	443	107	947
	2	7	30	266	37	327	100	885
		10	18	159	18	159	79	699
		13	30	266	43	381	106	938
20	1	21	30	266	50	443	99	876
		31	30	266	38	336	101	894
		3	51	451	74	655	226	2000
	2	4	80	708	130	1151	256	2266
		5	80	708	149	1319	256	2266
		7	80	708	113	1000	256	2266
31	10	54	478	54	478	216	1912	
	13	80	708	130	1151	256	2266	
	21	80	708	147	1301	256	2266	
31	2	31	80	708	113	1000	256	2266

Size	Number of Stages	Gear Ratio	Rated Torque		Repeated Peak Torque		Momentary Peak Torque	
			Nm	In-lb	Nm	In-lb	Nm	In-lb
32	1	3	153	1354	254	2248	625	5532
		4	198	1752	376	3328	625	5532
		5	200	1770	376	3328	625	5532
	2	7	200	1770	376	3328	625	5532
		10	185	1637	185	1637	625	5532
		13	200	1770	376	3328	625	5532
40	1	21	200	1770	376	3328	625	5532
		31	200	1770	376	3328	625	5532
		3	440	3894	752	6656	1137	10063
	2	4	460	4071	752	6656	1265	11196
		5	480	4248	752	6656	1265	11196
		7	510	4514	752	6656	829	7337
31	2	10	480	4248	509	4505	829	7337
		13	530	4691	752	6656	823	7284
		21	620	5487	752	6656	1029	9107
31	2	31	700	6196	752	6656	1097	9709

•Dimensions

Unit: mm

Size		11A	14A	30A	32A	40A
Symbol						
A (mm)		42	60	90	115	142
B (mm)	One Stage	93.5	117	160-184.5	200-264.5	282.5-328.5
	Two Stage	113	142	175-206.2	217.5-246.5	327-348

Dimensions depend upon the motor selected. Dimensions shown in the table are a typical range for reference only. Contact HDLLC for detailed dimensions of the gear used for your motor.

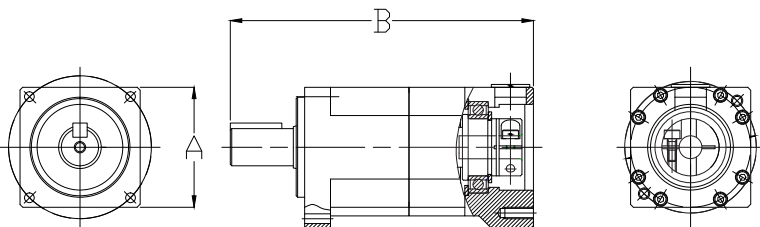

# Hollow Shaft Planetary Gear HPF Series



Hollow shaft planetary gear with output flange. The flange is integrated with a robust cross-roller bearing which can support high axial, radial and moment loads without the need for additional support bearings.

- Hollow Shaft Structure
- Coaxial input and output shafts
- Cross Roller Output Bearing
- Backlash < 3 arc-min
- The precision HPF planetary gear is also available in our SHA Series Hollow Shaft Brushless Actuators as a standard product

**L<sub>10</sub> Life: 20,000 h**

## •HPF Series Ratings

Item	Ratio	Rated Torque		Limit for Repeated Peak Torque		Limit for Momentary Torque	
		Nm	In-lb	Nm	In-lb	Nm	In-lb
25	11	21	186	100	885	170	1505
32	11	44	389	220	1947	450	3983

## • Cross Roller Bearing Specification

Item	Basic Rated Load				Allowable Moment Load Mc		Moment Stiffness Km	
	Basic Dynamic Rated Load C		Basic Static Rated Load Co		Nm	In-lb	x10 <sup>4</sup> Nm/rad	In-lb/arc.min
	N	lb	N	lb				
25	11400	2563	20300	4564	410	3629	37.9	335
32	22500	5058	39900	8970	932	8249	86.1	762

\*\*1: "Basic dynamic rated load" is a constant stationary radial load that achieves a basic dynamic rated life of the bearing of one million revolutions.

\*\*2: "Basic static rated load" is a static load that achieves a contact stress of a constant level (408kN/mm<sup>2</sup>) at the center of a contact zone between the rolling element receiving a maximum load and track.

Unit: mm

Size	25	32
A	136	167
B	105.1	125.5
C	25	30

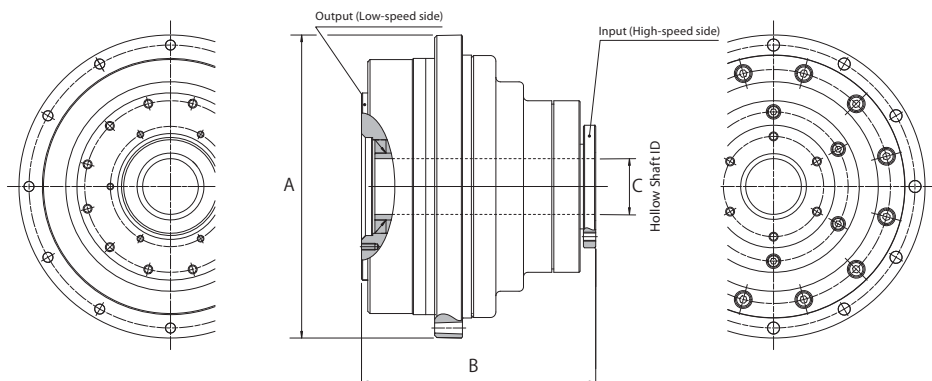



# Applications

## Robots



Industrial robots  
Robot peripheral equipment

Primary axis  
End effectors  
Linear axis  
Indexing table  
Peripheral equipment

- FHA-Mini
- FHA-C
- RSF
- Micro Encoder
- CSG
- CSD
- CSF
- SHG
- SHF
- SHD
- HPG

## Humanoid Robots

Humanoid Robots

Joint articulation  
Robotic hand  
Vision sensor positioning  
Torque sensing

- FHA-Mini
- FHA-C
- RSF-Supermini
- RSF-Mini
- Micro Encoder
- CSG
- CSD
- CSF
- SHG
- SHF
- SHD
- HPG



## Metal Machine Tools



Machining centers  
Turning centers  
NC lathes  
Work transfer systems  
Grinders  
EDM systems

Tool changer  
Tool magazine  
Work positioning equipment  
Rotary table  
C Axis

- FHA-C
- RSF
- LAH
- CSG
- CSF
- SHG
- SHF
- HPG

## Metal Working Machines

Bending machines  
Rolling machines  
Presses  
Work transfer systems

Bending axis  
Work positioning  
Work transfer

- FHA-C
- RSF
- LSA
- SHG
- SHF
- HPG



## Printing, Bookbinding and Paper Processing Machines



Printing presses  
Folding machines  
Paper changing machines  
Paper positioning machines  
Paper machines

Web tension control  
Cutting blade positioning  
Phase adjusting  
Roller height adjustment

- FHA-C
- RSF
- CSG
- CSF
- SHG
- SHF
- FB
- FR
- FD
- HPG

## Semiconductor Manufacturing Systems



Mask and reticle manufacturing  
 Wafer fabrication equipment  
 Wafer processing equipment  
 Test & Assembly equipment  
 Inspection equipment  
 Wafer transfer equipment

Wafer transfer robots  
 Positioning drive  
 Indexing tables  
 Wafer flipper  
 Valve opening/closing

FHA-Cmini	Micro Encoder
FHA-C	CSF
RSF	SHD
RSF-Supermini	SHF
KDU	HPG
RH	
LA	
LAH	

## Measurement, Analytical and Test Systems

Photometric equipment  
 Three-dimensional measuring instruments  
 Metal tensile test machines  
 Soil-column yield strength test machines

Transfer systems  
 Positioning drive  
 Prism positioning drive  
 Indexing tables  
 Direct transmission tables

FHA-C mini
RSF
RSF-Supermini
KDU
RH
LSA
Micro Encoder

CSF
SHF

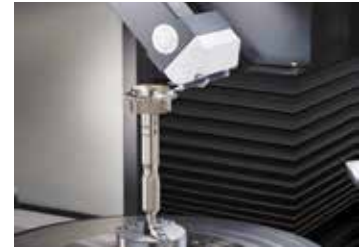

## Medical Equipment



Three-dimensional manipulators  
 X-ray photographing and CT-NMR systems  
 X-ray film developing and take-off machines  
 Surgical operation assistant robots

Precision joint drive  
 Bed lifting and inclination drive  
 Positioning table drive

FHA-Cmini
FHA-C
RSF
RH
CSF
SHF

## Optical Machines

X-ray analytical systems  
 Optical component inspection systems  
 Laser oscillation machines  
 Optical measuring instruments  
 Surface inspection systems  
 Optical disc manufacturing systems  
 Laser markers

Positioning table drive  
 Lens positioning drive  
 Laser mirror drive  
 Prism drive  
 Probe drive  
 Sensor positioning drive

FHA-Cmini
RSF
RSF-Supermini
KDU
RH
LSA
Micro Encoder
CSF
SHF

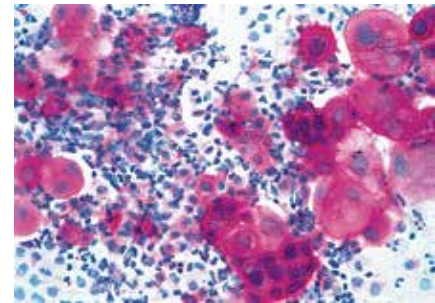

## Telescopes



Condenser mirror adjusting mechanisms  
 Electromagnetic wave micrometer adjusting mechanisms  
 Secondary mirror position control  
 Robot arms for maintenance servicing

X, Y, Z axis drive  
 Indirect drive mechanisms

FHA-Cmini
RSF-Supermini
RSF
KDU
LA
LAH
LBC
CSF
SHF
HPG

# Applications

## Wood, Light Metal and Plastic Machine Tools

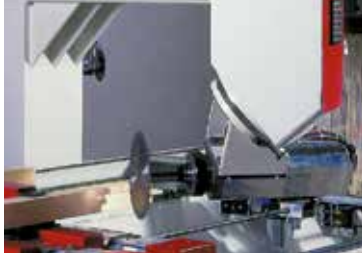

Woodworking machines  
5-shaft machining centers  
Large 3-dimension processing machines  
Work transfer systems

- Milling head drive
- Tool revolver drive
- Tool changer drive
- Tool magazine drive
- Work positioning machines
- Rotary table drive
- Tool positioning machine drive
- Direct transmission shaft drive
- Shaft drive

- FHA-Cmini
- FHA-C
- RSF
- RSF-Supermini
- LAH
- CSG
- CSF
- SHG
- SHF
- HPG

## Energy

Oil exploration robot  
Wind power equipment  
Electric power equipment  
Photovoltaics

- Digging angle positioning drive
- Propeller angle positioning drive
- Condensing board positioning drive

- FHA-C
- CSF
- FR



## Paper-making Machines



Paper-making machines  
Corrugated fiberboard box making and printing machines

- Coating-process roller positioning drive
- Head box slice lip positioning
- Cutter knife positioning
- Cutter knife traveling drive

- RSF
- FHA-C
- RH
- CSF
- SHF
- HPG

## Crating and Packaging Machines

Sealing machines  
Label printing machines  
Label attaching machines  
Robots  
Work transfer systems

- Shaft synchronizing drive
- Roll synchronizing drive
- Joint drive
- Trolley drive

- FHA-C
- RSF
- RH
- CSF
- SHF
- FB
- FR
- FD

HPG



## Flat Panel Display Manufacturing Systems



Array process equipment  
Cell process equipment  
Assembly process equipment  
Work transfer systems

- Transfer systems
- Parts positioning drive
- Indexing tables
- Direct transmission tables
- Work reversing machines
- Tension controllers
- Hatch opening/closing drive
- Joint drive
- Trolley drive

- FHA-Cmini
- FHA-C
- RSF
- RSF-Supermini
- KDU
- RH
- LA
- LAH
- CSF
- SHF
- SHD
- HPG

## Communication Equipment



Antennas  
Microphones  
Cameras  
Wavelength duplexers  
Radars

Pan & Tilt drives  
Prism drive

FHA-C mini  
FHA-C  
RSF  
RSF-Supermini  
RH  
LA  
LSA  
HPG

Micro Encoder

## Printed Circuit Board Manufacturing Machines

Electronic component  
insertion machines  
Solder paste dispensing  
machines  
Board inspection systems  
Transfer systems

Drilling head drive  
Tool changer drive  
Tool magazine drive  
Work positioning machines  
Rotary table drive  
Tool positioning machine drive  
Shaft drive

FHA-C mini  
FHA-C  
RSF  
RSF-Supermini  
LAH  
CSG  
CSF  
SHG  
SHF  
HPG



## Space



Communication  
Antennas  
Solar Array Drives  
Robotic joints  
Robotic arms

Pan & Tilt drive  
Joint drive  
Wheel drive

CSF  
SHF  
SHD

## Aircraft

Flight simulators  
Cargo handling and transfer  
systems  
Reconnaissance cameras  
Valves

Valve actuator  
Trolley drive  
Cargo wheel power  
drive unit  
Fly-by-Wire Components

FHA-Cmini  
FHA-C  
RSF  
RSF-Supermini  
RH  
CSF  
HPG



## Glass and Ceramic Manufacturing Systems



Ceramic forming machines  
Glass polishing machines  
Sheet glass cutting machines

Valve opening and closing  
Valve positioning  
Traveling trolley drive

FHA-Cmini  
FHA-C  
RSF  
LSA  
CSF  
SHF  
HPG



# Primary Application Areas



**Robots**



**Humanoid Robots**



**Printing, Bookbinding  
and Paper**

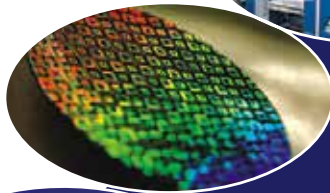

**Semiconductor Manufacturing  
Equipment**



**Optical Machines**



**Wood, Light Metal and Plastic  
Machine Tools**



**Paper-making Machines**



**Flat Panel Display  
Manufacturing Systems**



**Printed Circuit Board  
Manufacturing Machines**



**Aircraft**



**Metal Working Machine**



**Processing Machines**



**Measurement, Analytical and Test Systems**



**Medical Equipment**



**Telescopes**



**Energy**



**Packaging Machines**



**Communication Equipment**



**Space Flight**



**Glass and Ceramic Manufacturing Systems**

All products are warranted to be free from design or manufacturing defects for a period of one year from the date of shipment. Such items will be repaired or replaced at the direction of Harmonic Drive LLC. The seller makes no warranty, express or implied, concerning the material to be furnished other than it shall be of the quality and specifications stated. The seller's liability for any breach is limited to the purchase price of the product. All efforts have been made to assure that the information in this catalog is complete and accurate. However, Harmonic Drive LLC is not liable for any errors, omissions or inaccuracies in the reported data. Harmonic Drive LLC reserves the right to change the product specifications, for any reason, without prior notice. For complete details please refer to our current Terms and Conditions posted on our website.

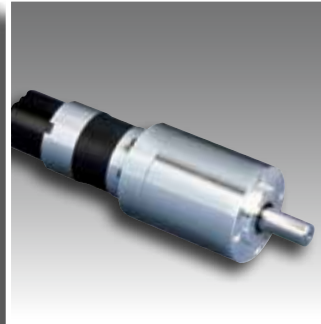
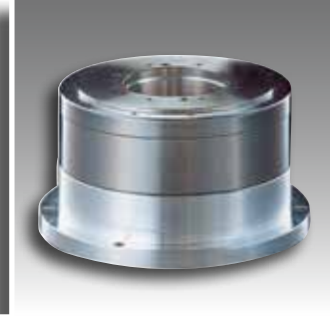
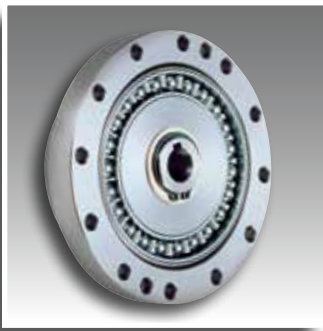

## Harmonic Drive LLC

### Boston US Headquarters

247 Lynnfield Street  
Peabody, MA 01960

### New York Sales Office

100 Motor Parkway  
Suite 116  
Hauppauge, NY 11788

### California Sales Office

333 W. San Carlos Street  
Suite 1070  
San Jose, CA 95110

### Chicago Sales Office

137 N. Oak Park Ave., Suite 410  
Oak Park, IL 60301

T: 800.921.3332

T: 978.532.1800

F: 978.532.9406

[www.HarmonicDrive.net](http://www.HarmonicDrive.net)

Harmonic Drive, Harmonic Planetary and Infnit-Indexer are registered trademarks, and Quick Connect is a trademark of Harmonic Drive LLC.

### Group Companies

Harmonic Drive Systems, Inc.  
6-25-3 Minami-Ohi, Shinagawa-ku  
Tokyo 141-0013, Japan

Harmonic Drive AG  
Hoenbergstrasse, 14, D-6555  
Limburg/Lahn Germany

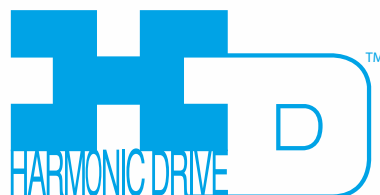

Rev 20161031