

H116SPN

Motorised semi-conductor wafer inspection shuttle stage for Nikon wafer handling systems

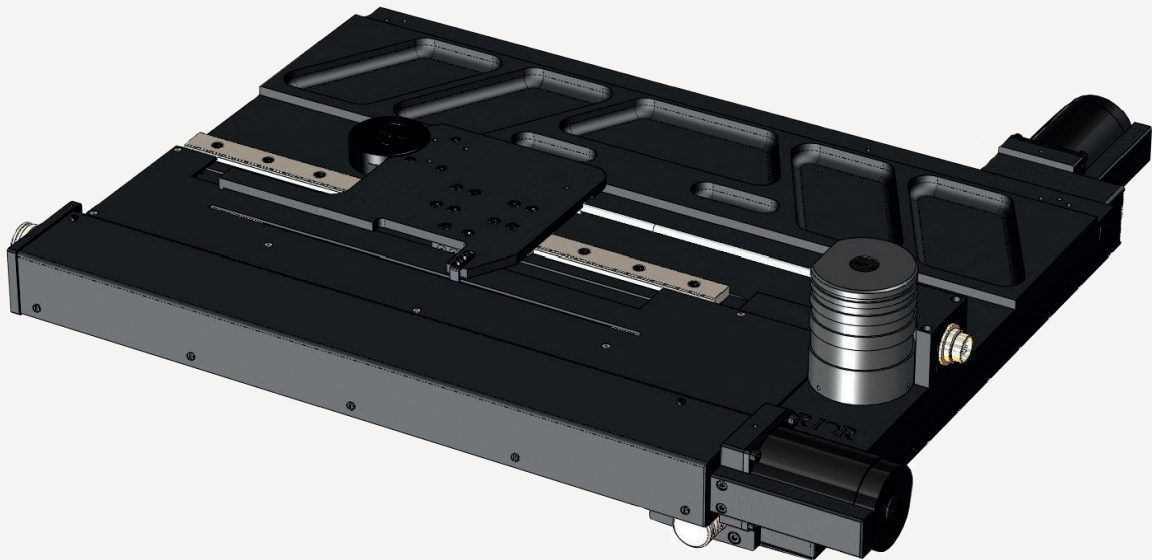

The Prior Scientific motorised shuttle stage is designed to be used for wafer inspection, using the Nikon NWL200 and NWL860 wafer handling systems. The stage also reduces operator error and fatigue whilst increasing the rate at which wafers are inspected.

The H116SPN automatically loads and unloads wafers. When operating the shuttle system automatically moves to the correct load position and activates the loader switch, notifying the loader that the wafer chuck is ready to receiving the wafer. After transfer to the shuttle the shuttle is retracted allowing for inspection. Either a manual inspection process using a joystick, or a pre programmed inspection pattern, are possible.

The H116SPN has a large travel range coupled with superb repeatability and resolution. When used in conjunction with Prior's ProScan® system, it ensures accuracy, precision and ultimately a more effective and efficient wafer inspection process.

- Travel range of 250 x 210 mm
- Resolution of 0.04 μm
- Repeatability $\pm 0.2 \mu\text{m}$
- Automatically loads and unloads wafers
- Compatible with the ProScan III system and Nikon NWL200/NWL860 wafer handling systems

H116SPN

Motorised semi-conductor wafer inspection shuttle stage for Nikon wafer handling systems

Dimensions

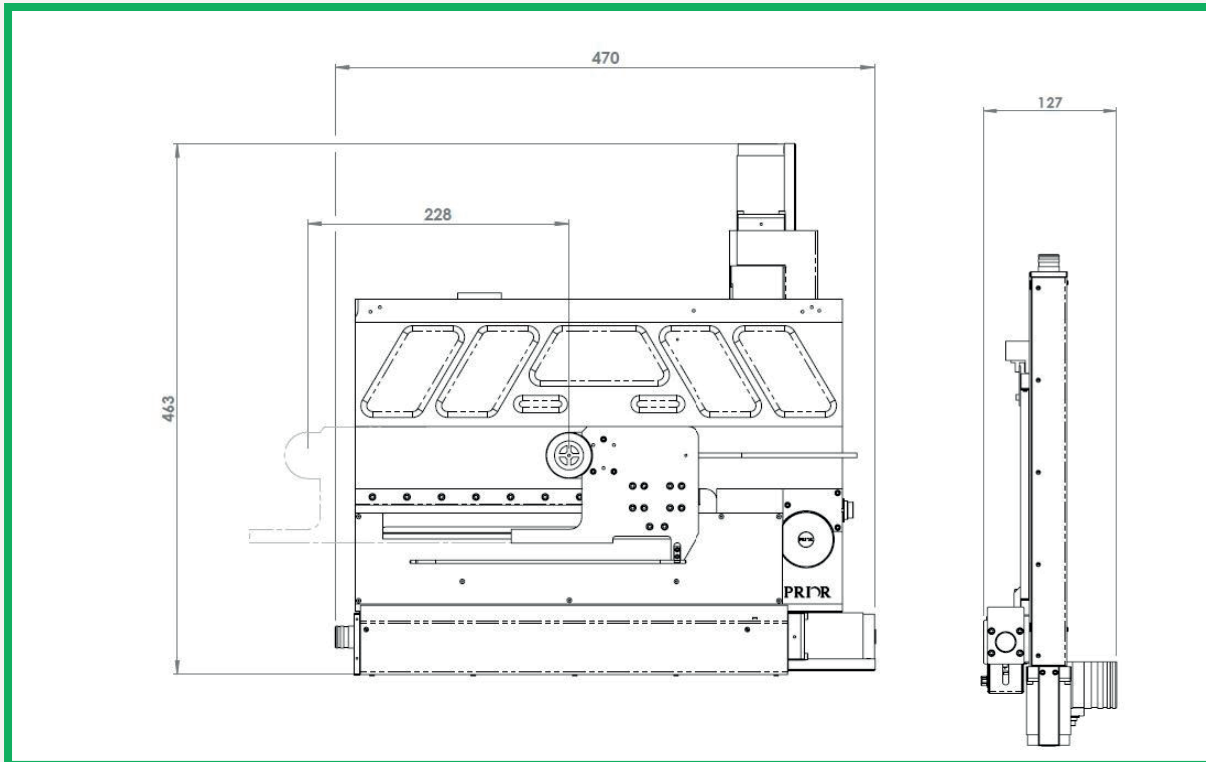

Specification*

| Feature | Specification |
|--------------------------------|---------------|
| Bi-directional repeatability | ± 1.3 µm |
| Uni-directional repeatability | ± 0.2 µm |
| Minimum step size (resolution) | 0.04 µm |
| Recommended speed | 40 mm/s |
| Maximum travel range | 250 x 210 mm |
| Ball Screw pitch | 2 mm |
| Motor Type | 200 SPR |
| Weight | 9 Kg |

* To obtain these values requires the use of a Prior ProScan II or above controller. Using the Prior method of testing with backlash correction enabled. All repeatability is uni-directional.



Prior Scientific Ltd

3-4 Fielding Industrial Estate • Wilbraham Road • Fulbourn • Cambridge • CB21 5ET • UK
 t: +44 (0)1223 881711 • e: uksales@prior.com • www.prior-scientific.co.uk



FM 61600



Prior Scientific Inc

80 Reservoir Park Drive • Rockland • MA. 02370 • U.S.A.
 t: +1 781-878-8442 • e: info@prior.com • www.prior-us.com

Registered Address: Units 3/4 Fielding Industrial Estate • Wilbraham Road • Fulbourn • Cambridge • CB21 5ET • United Kingdom Registered in England 404087