

Hub City HERA® - High-Efficiency Right Angle Gear Drives



Features	H-2
Online Tools and Apps	H-3
Why HERA®? and Ordering Information	H-4
Selection and Ratings.	H-5
HERA® Dimensions	H-6
Accessories	H-7 to H-10
Engineering Information	H-10
Helical-HERA® Compound Speed Reducer Assemblies.	H-11
Double HERA® Speed Reducer Assemblies.	H-12 to H-13
Competitor Interchange Guide	H-14

Hub City HERA® - High-Efficiency Right Angle Gear Drives

90% Efficiency – 2x More Torque
No Hassle Replacement for Worm Gear Drives

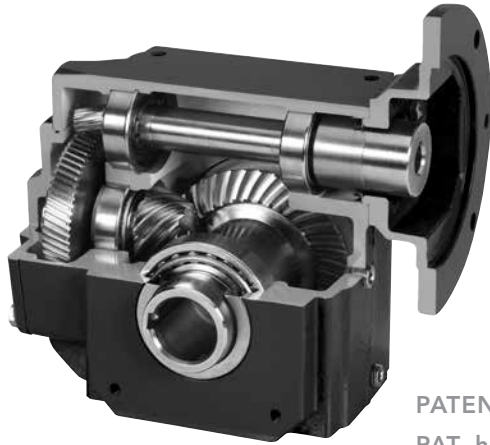

PATENTED
PAT. <http://rbcm.biz/q=F3A63>



Basic Specifications

- Power Ratings to 27 HP
- Output Torque to 8500 in. lbs.
- Operating Speeds to 2500 rpm

Standard Features

- Four sizes of HERA® drives can replace up to eleven sizes of worm speed reducers
- Rolling action gearing (Helical and Hypoid) – significant wear particle reduction & increased power density
- Over-sized bearings – increased L-10 life
- Viton seals – enhanced protection at higher operating temperatures
- Bronze Bushing Quill Liner to prevent fretting and for easy motor removal (56C & 143TC)
- Factory filled with PAG lubricant – longer life – USDA H1 accepted
- Higher efficiency = lower operating temp = increased seal life
- Two Models available in Stainless Steel – See Section O

Optional Features

- Modified Standard and Custom Designs
- CleanLine™ and BISSC for food service and/or washdown applications
- Metric Versions to meet Global Market Demands
- Accessories Assembled to units on request

HubLoc™ Keyless Bushing System

- The HubLoc™ system is versatile, robust, easily installed, and creates a keyless, backlash-free mechanical interference fit that eliminates the micromovement that causes fretting and cold welding.
- Available in a wide range of standard bores, with custom bores available upon request.
- Tamper Resistant HubCap™ protective covers are made from metal-detectable plastic to support customer HACCP programs.
- Refer to pages i and ii at front of this catalog for features, available sizes, and ordering information.



Hub City HERA® - High-Efficiency Right Angle Gear Drives

Online Tools & Apps



HERA® Selector

- Android and i-Phone
- Select using physical parameters
- Select using competitor worm model number
- Shows unit and applicable kits, along with ratings
- Ask for HERA® Selector on i-Tunes or Google Play Marketplace

Product Search & 3D Model Configurator

- User friendly
- Quick navigation
- Native CAD files
- Find on the Hub City website under Tools > 3D Model Configurator & CAD

powered by PARTolutions™

0250-56457

Sizing Options

Model Number: HERA35

Assembly Style: IS

Ratio: 8.02

Frame Size: 143TC

Output Diameter: 3/4 [INCH]

3D Preview 2D View CAD Download Help

Hera - Dimensional Data

Part Number	Style	Gear Type	Description	Product Type	Product Line	Input Type	Input Diameter [INCH]
0250-56457	N/A	N/A	HERA35ES 8.02 143TC 0.750	Right Angle	Hera	Motor Frame	0.876

Part # 0250-56457 (HERA35ES 8.02 143TC .750)

Update & Display Product Overview Login to add to RFQ Cart

Hub City Series HERA (patented)

NOTE: If this page is not displaying correctly, please confirm that your web browser is at least version IE6 or higher or you may also try viewing it with Firefox (also works well when going to the Configurator)

Quick Search: Login for CAD Download: Email Password

Hub City Series HERA

90% efficiency & Up to 2X more torque --- In a No-Hassle Worm Gear Drive replacement!

Category: Gear Drives & Speed Reducers
Family: HERA High Efficiency Right Angle Gear Drives

Search Series

Model HERA35
HERA™ High Efficiency Right Angle Gear Drive
Power ratings to 4 HP
Available in C-face quill or coupled styles
Shaft input
Sized to replace 1.75" to 2.38" center distance worm speed reducers (with available accessories)
Ratio range to 60:1 (nominal)
[CAD Configurator](#)
[View Accessories](#)

Model HERA45
HERA™ High Efficiency Right Angle Gear Drive
Power ratings to 8.5 HP
Available in C-face quill or coupled styles
Shaft input
Sized to replace 2.38" to 3.25" center distance worm speed reducers (with available accessories)
Ratio range to 60:1 (nominal)
[CAD Configurator](#)
[View Accessories](#)

HERA®
H

Hub City HERA® - High-Efficiency Right Angle Gear Drives

Why HERA®?

- Up to 40% more efficient than standard worm gearing
- Available with a variety of Marathon Premium Efficiency motors for even more energy savings (recommended)
- Increased Torque Density and Efficiency allow for downsizing of units and motors
- Longer life expectancy than that of standard worm gearing
- Rapid payback – Up to \$550 savings per year with each increment of motor HP
- Three year warranty

Worm System

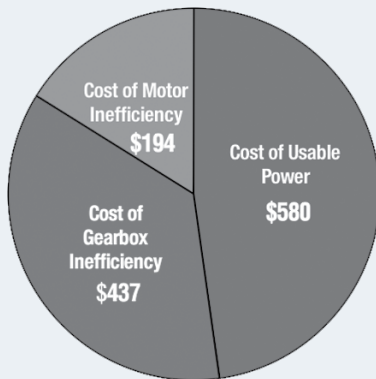

Annual Operating Cost (total): \$1,211

HERA System

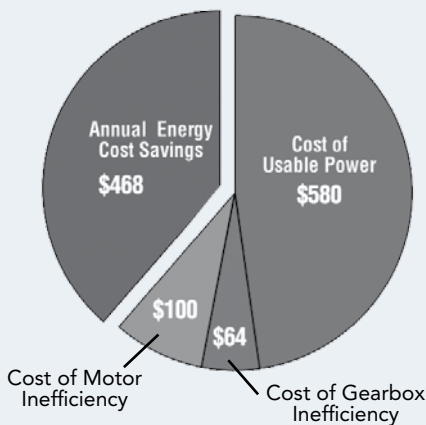

Annual Operating Cost (total): \$744

Energy Savings Example

	WORM SYSTEM	HERA SYSTEM
Gearbox Description	3.25" Worm	HERA45
Gearbox Ratio (to 1)	60/1	59.79
Motor Description	Standard 3-Ph	Marathon Globetrotter®
Motor Rating (HP)	3 HP	1.5 HP
Motor Efficiency	84%	87%
Gearbox Operating Efficiency	57%	90%
Cost of Usable Power	\$580	\$580
Cost of Gearbox Inefficiency	\$437	\$64
Cost of Motor Inefficiency	\$194	\$100
Annual Operating Cost (total)	\$1,211	\$744
Annual Energy Cost Savings		\$468

Individual results may vary.

HERA45 BENEFITS

• 39% Energy Savings	• 4700 kW-hrs Saved Annually
• Smaller Motor Requirements	• CO ₂ Savings = Over 2.5 tons

Go Online to Calculate Your Savings!

www.hubcityinc.com/energy_calculator/efficiency_calculator.html

HERA® Ordering Information

HERA45

Basic Model

HERA35
HERA45
HERA55
HERA75

E

Input Style

A: Shaft Input
E: C-face Quill
P: C-face Coupled

S

Output Style

S: (Sleeve) Hollow Bore
K: HubLoc™ (Keyless Bushing)

28.01

Exact Ratio

See Ratings Chart for Available Ratios

143TC

Frame Size

See Dimensional Table for Available Frame Sizes

1.438

Bore Size

See Stock Bores Table

0259-00096

Shaft Kit

See Accessories Page For available Accessories

0259-00083

B-Base Kit

Hub City HERA® - High-Efficiency Right Angle Gear Drives

Selection Procedure

Step 1

Select Basic Model

Using the rating chart below, select basic model and ratio based on application Hp, service factor and output torque requirements (Please note color-coding for quick selection by motor HP). OR, if interchanging from competitor worm drive, use the interchange chart on back of this brochure to select the basic model.

Basic Model Quick Selection By Motor HP

1.0 SERVICE FACTOR @ 1750 RPM INPUT

NOM. RATIO	1/2	3/4	1	1-1/2	2	3	5	7-1/2	10	15	20
7/1	35	35	35	35	35	35	45	45	55		
10/1	35	35	35	35	35	45	45	55	55	75	75
15/1	35	35	35	35	35	45	45	55	75	75	
20/1	35	35	35	35	45	45	55	75	75		
30/1	35	35	35	45	45	55	75	75			
40/1	35	35	45	45	45	55	75				
50/1	35	45	45	45	55	75					
60/1	35	45	45	55	55	75					

Consult factory for high efficiency right angle drives suited for these power ratings.



Try the new HERA Selector app for Android and iPhone.

HERA® Power Ratings (@ 1.0 SERVICE FACTOR)

NOM. RATIO	INPUT RPM	EFF. (%)	HERA35			HERA45			HERA55			HERA75		
			EXACT RATIO	INPUT HP	OUTPUT TORQUE (IN. LBS.)	EXACT RATIO	INPUT HP	OUTPUT TORQUE (IN. LBS.)	EXACT RATIO	INPUT HP	OUTPUT TORQUE (IN. LBS.)	EXACT RATIO	INPUT HP	OUTPUT TORQUE (IN. LBS.)
7/1	2500	90	8.02	2.00	364	7.80	8.50	1504	7.94	13.00	2342	-	-	-
10/1	2500	90	11.42	2.00	518	11.36	7.50	1933	10.77	13.00	3177	9.58	18.00	3912
15/1	2500	90	15.60	2.00	708	15.60	7.00	2478	15.05	9.50	3244	15.05	15.00	5122
20/1	2500	90	19.93	2.00	905	19.50	5.88	2600	21.15	8.00	3839	21.15	13.00	6238
30/1	2500	90	29.10	1.67	1100	28.01	4.09	2600	30.14	6.58	4500	30.14	12.43	8500
40/1	2500	90	43.53	1.11	1100	39.98	2.87	2600	43.97	4.51	4500	37.33	10.04	8500
50/1	2500	90	52.50	0.92	1100	52.50	2.18	2600	53.03	3.74	4500	53.03	7.06	8500
60/1	2500	90	58.33	0.83	1100	59.79	1.92	2600	58.92	3.37	4500	58.92	6.36	8500
7/1	1750	90	8.02	4.23	1100	7.80	8.50	2149	7.94	13.00	3346	-	-	-
10/1	1750	90	11.42	2.97	1100	11.36	7.06	2600	10.77	12.89	4500	9.58	27.37	8500
15/1	1750	90	15.60	2.18	1100	15.60	5.14	2600	15.05	9.22	4500	15.05	17.42	8500
20/1	1750	90	19.93	1.70	1100	19.50	4.11	2600	21.15	6.56	4500	21.15	12.40	8500
30/1	1750	90	29.10	1.17	1100	28.01	2.86	2600	30.14	4.61	4500	30.14	8.70	8500
40/1	1750	90	43.53	0.78	1100	39.98	2.01	2600	43.97	3.16	4500	37.33	7.02	8500
50/1	1750	90	52.50	0.65	1100	52.50	1.53	2600	53.03	2.62	4500	53.03	4.95	8500
60/1	1750	90	58.33	0.58	1100	59.79	1.34	2600	58.92	2.36	4500	58.92	4.45	8500
7/1	1150	90	8.02	2.78	1100	7.80	6.76	2600	7.94	11.49	4500	-	-	-
10/1	1150	90	11.42	1.95	1100	11.36	4.64	2600	10.77	8.47	4500	9.58	17.99	8500
15/1	1150	90	15.60	1.43	1100	15.60	3.38	2600	15.05	6.06	4500	15.05	11.45	8500
20/1	1150	90	19.93	1.12	1100	19.50	2.70	2600	21.15	4.31	4500	21.15	8.15	8500
30/1	1150	90	29.10	0.77	1100	28.01	1.88	2600	30.14	3.03	4500	30.14	5.72	8500
40/1	1150	90	43.53	0.51	1100	39.98	1.32	2600	43.97	2.07	4500	37.33	4.62	8500
50/1	1150	90	52.50	0.42	1100	52.50	1.00	2600	53.03	1.72	4500	53.03	3.25	8500
60/1	1150	90	58.33	0.38	1100	59.79	0.88	2600	58.92	1.55	4500	58.92	2.92	8500
7/1	850	90	8.02	2.06	1100	7.80	5.00	2600	7.94	8.49	4500	-	-	-
10/1	850	90	11.42	1.44	1100	11.36	3.43	2600	10.77	6.26	4500	9.58	13.30	8500
15/1	850	90	15.60	1.06	1100	15.60	2.50	2600	15.05	4.48	4500	15.05	8.46	8500
20/1	850	90	19.93	0.83	1100	19.50	2.00	2600	21.15	3.19	4500	21.15	6.02	8500
30/1	850	90	29.10	0.57	1100	28.01	1.39	2600	30.14	2.24	4500	30.14	4.23	8500
40/1	850	90	43.53	0.38	1100	39.98	0.97	2600	43.97	1.53	4500	37.33	3.41	8500
50/1	850	90	52.50	0.31	1100	52.50	0.74	2600	53.03	1.27	4500	53.03	2.40	8500
60/1	850	90	58.33	0.28	1100	59.79	0.65	2600	58.92	1.14	4500	58.92	2.16	8500
7/1	100	90	8.02	0.24	1100	7.80	0.59	2600	7.94	1.00	4500	-	-	-
10/1	100	90	11.42	0.17	1100	11.36	0.40	2600	10.77	0.74	4500	9.58	1.56	8500
15/1	100	90	15.60	0.12	1100	15.60	0.29	2600	15.05	0.53	4500	15.05	1.00	8500
20/1	100	90	19.93	0.10	1100	19.50	0.24	2600	21.15	0.38	4500	21.15	0.71	8500
30/1	100	90	29.10	0.07	1100	28.01	0.16	2600	30.14	0.26	4500	30.14	0.50	8500
40/1	100	90	43.53	0.04	1100	39.98	0.11	2600	43.97	0.18	4500	37.33	0.40	8500
50/1	100	90	52.50	0.04	1100	52.50	0.09	2600	53.03	0.15	4500	53.03	0.28	8500
60/1	100	90	58.33	0.03	1100	59.79	0.08	2600	58.92	0.13	4500	58.92	0.25	8500

Additional ratios from 70/1 to 420/1 are available by adding a Helical Ratio Multiplier to HERA (see page H-11).
 Additional ratios from 86/1 to as high as 3,487/1 are available by ordering a HERA Compound Reducer Assembly (see page H-12).
 NOTE: All Ratios will backdrive due to High Efficiency Gearing.

EMAIL: hubsales@regalbeloit.com • www.hubcityinc.com



Hub City HERA® - High-Efficiency Right Angle Gear Drives

Selection Procedure

Step 2

Select Input Type

- E - C-face (quill), Select available frame size (G)
- P - C-face (coupled), Select available frame size (G)
- A - Shaft input, Select shaft diameter desired (G)

FOR LUBRICATION AND INSTALLATION INSTRUCTIONS - REFER TO SECTION S. DIMENSIONS SHOWN ARE FOR REFERENCE ONLY. DOWNLOAD AVAILABLE CAD MODELS AT: WWW.HUBCITYINC.COM

HERA® Model Dimensions

E - C-face (quill)

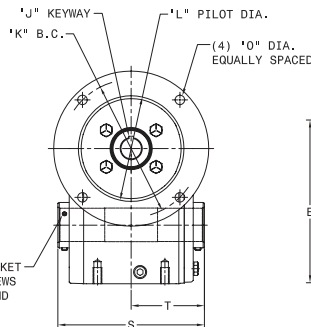
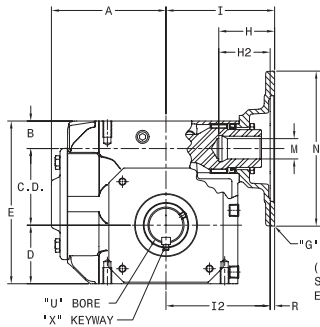

P - C-face (coupled)

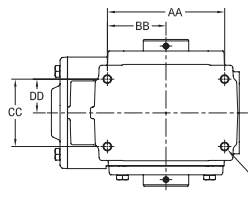

Modified units are available, consult factory.

THESE UNITS CAN BE FURNISHED WITH SOLID OUTPUT SHAFT ON SPECIAL ORDERS.

SHAFT MOUNTED UNITS REQUIRE TORQUE ARMS. TORQUE ARM KITS ARE AVAILABLE.

(4) 'EE' NC (TOP AND BOTTOM)
'FF' DEEP TOP
'GG' DEEP BOTTOM

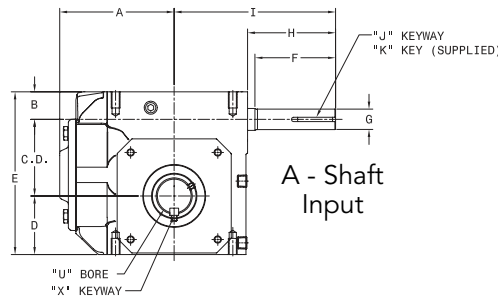

A - Shaft Input

Stock Bores

U	X
HERA35	
3/4	3/16 X 3/32
7/8	3/16 X 3/32
1	1/4 X 1/8
1-1/8	1/4 X 1/8
1-3/16	1/4 X 1/8
1-1/4	1/4 X 1/8
1-7/16	3/8 X 1/8
HERA45	
1	1/4 X 1/8
1-1/8	1/4 X 1/8
1-3/16	1/4 X 1/8
1-1/4	1/4 X 1/8
1-7/16	3/8 X 1/8
1-1/2	3/8 X 1/8
HERA55	
1-3/16	1/4 X 1/8
1-1/4	1/4 X 1/8
1-7/16	3/8 X 3/16
1-1/2	3/8 X 3/16
1-5/8	3/8 X 3/16
1-11/16	3/8 X 3/16
1-3/4	3/8 X 3/16
1-7/8	1/2 X 1/4
1-15/16	1/2 X 3/16
2	1/2 X 3/16
2-3/16	1/2 X 1/8
HERA75	
1-7/16	3/8 X 3/16
1-1/2	3/8 X 3/16
1-15/16	1/2 X 1/4
2	1/2 X 1/4
2-3/16	1/2 X 1/4
2-7/16	5/8 X 5/16
3	3/4 X 3/8
3-7/16	7/8 X 1/4

Step 3

Select Output Arrangement

- K - HubLoc™ (Keyless Bushing) System
- S - Hollow Bore (choose bore size)
- Shaft Output - choose shaft kit from accessory page

Note: must order appropriate bore size in unit required for shaft kit

Model Dimensions

MODEL	C.D.	A	B	D	E	AA	BB
HERA35	2.509	4.25	1.178	2.062	5.750	4.188	2.094
HERA45	3.263	4.88	1.175	2.500	6.938	5.000	2.500
HERA55	3.675	6.15	2.200	3.500	9.375	7.500	3.750
HERA75	4.287	8.36	2.650	4.438	11.375	8.500	4.250

Model Dimensions

MODEL	CC	DD	EE	FF	GG	S	T
HERA35	2.750	1.375	5/16 UNC	.63	.63	5.50	2.75
HERA45	2.875	1.438	3/8 UNC	.69	.69	6.25	3.13
HERA55	4.000	2.000	7/16 UNC	.88	.88	7.50	3.75
HERA75	5.000	2.500	5/8 UNC	1.00	1.00	9.50	4.75

Shaft Input Dimensions

MODEL	SIZE REF.	F	G	H	I	J	K
HERA35AS	18	1.56	.6245/.6235	1.94	4.88	3/16 X 3/32	3/16 SQ X 1-1/4
	21	2.00	.7495/.7485	2.38	5.31		3/16 SQ X 1-1/2
	24	2.00	.7495/.7485	2.38	5.50		3/16 SQ X 1-1/2
26	2.81	.8745/.8735	3.19	6.31			
30	3.44		3.76	6.88			
HERA45AS	32	4.00	.8745/.8735	4.32	7.44	3/16 X 3/32	3/16 SQ X 1-1/2
	32	2.07		.8745/.8735	2.38		
	HERA55AS	38	3.70	.9995/.9985	4.01		
42		4.88	1.2495/1.2485	5.19	9.56		
32		2.07	.8745/.8735	2.38	7.63		
HERA75AS	42	4.00	1.2495/1.2485	4.31	9.56	3/16 X 3/32	1/4 SQ X 2-1/4
	52	5.00		5.44	10.69		

C-Face Input Dimensions

C-FLANGE MODELS		ES MODELS				PS MODELS				BOTH ES & PS MODELS											
MODEL	G	H	H2	I	I2	H	H2	I	I2	J	K	L	M	N	O	R	WT. LBS.				
HERA35	56C	2.27	N/A	4.44	N/A	2.25	N/A	7.57	N/A	3/16 X 3/32	5.875	4.501/4.503	.625	6.63	13/32	.188	30				
	143TC	2.38										.875									
HERA45	56C	2.27	N/A	4.63	N/A	2.25	N/A	7.76	N/A	3/16 X 3/32	5.875	4.501/4.503	.625	6.63	13/32	.188	43				
	143TC	2.38										.875									
	182TC	N/A	2.89	N/A	5.06	N/A	3.25	N/A	8.76	1/4 X 1/8	7.250	8.501/8.503	1.125					9.00	17/32	.188	50
HERA55	56C	2.27	N/A	5.57	N/A	2.25	N/A	9.00	N/A	3/16 X 3/32	5.875	4.501/4.503	.625	6.63	13/32	.188	82				
	143TC	2.38										.875									
	182TC	N/A	2.89	N/A	6.33	N/A	3.25	N/A	10.00	1/4 X 1/8	7.250	8.501/8.503	1.125					9.00	17/32	.188	90
	213TC	N/A	3.63							5/16 X 5/32			1.625								
256TC	N/A	3.88							3/8 X 3/16			1.625									
HERA75	56C	2.27	N/A	6.45	N/A	2.25	N/A	9.88	N/A	3/16 X 3/32	5.875	4.501/4.503	.625	6.63	13/32	.188	167				
	143TC	2.38										.875									
	182TC	N/A	2.89	N/A	7.21	N/A	3.25	N/A	10.88	1/4 X 1/8	7.250	8.501/8.503	1.125					9.00	17/32	.188	175
	213TC	N/A	3.63							5/16 X 5/32			1.375								
256TC	N/A	3.88							3/8 X 3/16			1.625									

Hub City HERA® - High-Efficiency Right Angle Gear Drives

Accessories

Step 4

Select Accessories

- B - Interchange base (required if interchanging to larger size worm gear reducer) provides appropriate "D" dimension and tapped mounting hole dimensions & pattern
- T - Base (includes B-base above) provides means to bolt unit from above mounting surface and matches competitor worm mounting base bolt patterns
- F - Flanges, provide means for side mounting
- Other available accessories: Vertical base kits, torque arm kits, C-flange adapter kits

Plug-In Shaft Kits

SERIES	SIZE REF.	STOCK BORE REQUIRED	DOUBLE EXT KIT NO.	SINGLE EXT KIT NO.	S	T	T2	U	V	W	W2	X	Y	KEY(S) FURNISHED	WT. LBS.
HERA35	18	1.438	0259-00135	0259-00136	8.62	4.31	2.97	.875	2.05	1.38	1.34	3/16 x 3/32	1.13	3/16 SQ X 1-1/8	4.1
	21		0259-00137	0259-00138	9.38	4.69	2.97	1.000	2.43	1.76	1.72	1/4 X 1/8	1.50	1/4 SQ X 1-1/2	4.4
	24		0259-00139	0259-00140	10.28	5.14	2.97	1.125	2.88	2.21	2.17	1/4 X 1/8	1.75	1/4 SQ X 1-3/4	4.9
HERA45	24	1.438	0259-00092	0259-00093	10.28	5.14	3.45	1.125	2.50	1.77	1.69	1/4 X 1/8	1.50	1/4 SQ X 1-1/2	5.2
	26		0259-00094	0259-00095	11.25	5.63	3.44	1.125	2.99	2.25	2.18	1/4 X 1/8	2.00	1/4 SQ X 1-3/4	5.7
	30		0259-00096	0259-00097	13.50	6.75	3.45	1.250	4.11	3.38	3.30	1/4 X 1/8	2.25	1/4 SQ X 2-1/4	6.6
	32		0259-00098	0259-00099	14.12	7.06	3.45	1.375	4.42	3.69	3.64	5/16 X 5/32	2.50	5/16 SQ X 2-3/8	7.3
HERA55	32	1.938	0259-00117	0259-00118	14.12	7.06	4.06	1.375	3.91	3.06	3.00	5/16 X 5/32	2.50	5/16 SQ X 2-3/8	10.0
	35		0259-00167	0259-00168	14.12	7.06	4.06	1.500	3.91	3.06	3.00	3/8 x 3/16	2.50	3/8 SQ X 2	10.0
	38		0259-00119	0259-00120	15.50	7.75	4.06	1.625	4.60	3.75	3.69	3/8 X 3/16	2.81	3/8 SQ X 2-1/2	11.8
	42		0259-00121	0259-00122	16.24	8.12	4.06	1.875	4.97	4.12	4.03	1/2 X 1/4	3.31	1/2 SQ X 3-1/4	13.8
HERA75	42	2.438	0259-00153	0259-00154	16.24	8.12	5.12	1.875	4.00	3.06	3.00	1/2 X 1/4	2.56	1/2 SQ X 2-1/2	TBD
	52		0259-00155	0259-00156	18.12	9.06	5.12	2.000	4.94	4.00	3.94	1/2 X 1/4	3.56	1/2 SQ X 3-1/2	TBD
	60		0259-00164	0259-00165	20.00	10.00	5.12	2.250	5.88	4.94	4.88	1/2 X 1/4	3.56	1/2 SQ X 3-1/2	TBD

Base Kits

B - Base Kit

HERA® B-bases provide a drop-in mounting solution when replacing comparable rated worm gear reducers.

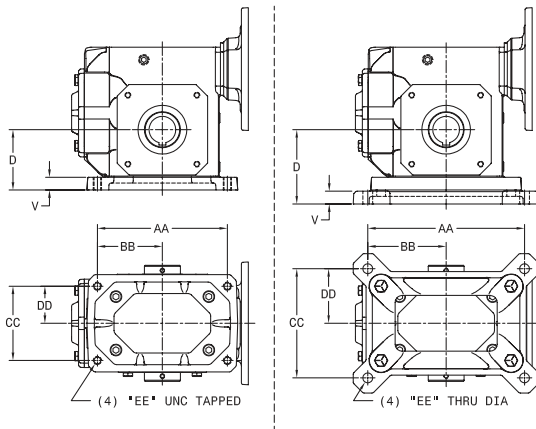

T - Base Kit

HERA® B-bases provide a drop-in mounting solution when replacing comparable rated worm gear reducers that also are utilizing a horizontal mounting base.

Plug-In Shaft Kits

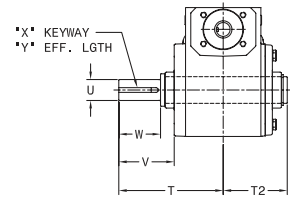

Single Extended
Note: Single Extended Kit can be installed from either side.

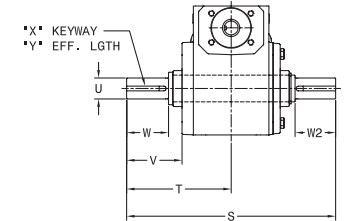

Double Extended

B - Base Kits

SERIES	B-BASE KIT NO.	SHIPPING WT. LBS.	SIZE REF.	D	V	AA	BB	CC	DD	EE
HERA35	0259-00130	1.3	21	2.281	0.22	5.00	2.50	2.88	1.44	3/8 UNC
	0259-00131	2.0	24	2.500	0.38	5.00	2.50	2.88	1.44	3/8 UNC
HERA45	0259-00082	2.5	26	2.938	0.38	6.38	3.19	3.38	1.69	3/8 UNC
	0259-00083	4.3	30	3.25	0.69	7.00	3.50	4.00	2.00	7/16 UNC
HERA45	0259-00084	5.0	32	3.500	0.88	7.50	3.75	4.00	2.00	7/16 UNC
	0259-00276	4.0	35	3.990	0.49	7.50	3.75	4.00	2.00	7/16 UNC
HERA55	0259-00112	4.0	38	3.875	0.38	8.50	4.25	4.75	2.38	1/2 UNC
	0259-00113	7.5	42	4.438	0.88	8.50	4.25	5.00	2.50	5/8 UNC
HERA75	0259-00150	13	52	5.313	0.79	11.00	5.50	5.81	2.91	5/8 UNC
	0259-00162	21	60	6.500	1.50	12.75	6.38	6.38	3.19	5/8 UNC

T - Base Kits

SERIES	T-BASE KIT NO.	SHIPPING WT. LBS.	SIZE REF.	D	V	AA	BB	CC	DD	EE
HERA35	0259-00132	3.0	18	2.75	0.63	5.75	2.88	4.5	2.25	0.41
	0259-00133	4.8	21	3.000	0.66	6.38	3.19	4.69	2.34	0.47
	0259-00134	9.0	24	3.25	0.69	7.06	3.53	4.88	2.44	0.47
HERA45	0259-00186	6.0	24	3.25	0.69	7.06	3.53	4.88	2.44	0.47
	0259-00085	7.0	26	3.688	0.69	8.00	4.00	5.25	2.63	0.53
	0259-00086	9.5	30	4.000	0.69	8.44	4.22	5.88	2.94	0.53
HERA45	0259-00087	11.5	32	4.375	0.81	9.5	4.75	6.13	3.06	0.53
	0259-00114	6.5	32	4.375	0.81	9.5	4.75	6.13	3.06	0.53
	0259-00115	12.5	38	4.812	0.88	10.38	5.19	7.00	3.50	0.59
HERA55	0259-00116	19	42	5.438	0.94	11.13	5.56	7.63	3.81	0.66
	0259-00151	13	42	5.438	0.94	11.13	5.56	7.63	3.81	0.66
	0259-00152	27	52	6.438	1.06	14.13	7.06	8.38	4.19	0.78
HERA75	0259-00163	52	60	7.750	1.12	16.50	8.25	9.50	4.75	0.91

DIMENSIONS SHOWN ARE FOR REFERENCE ONLY.
DOWNLOAD AVAILABLE CAD MODELS AT:
WWW.HUBCITYINC.COM

Output Cover Kits



SERIES	PART NO.
HERA35	0259-00184
HERA45	0259-00185
HERA55	NA
HERA75	NA

Contact Factory for dimensions on cover kits.

Hub City HERA® - High-Efficiency Right Angle Gear Drives

Accessories

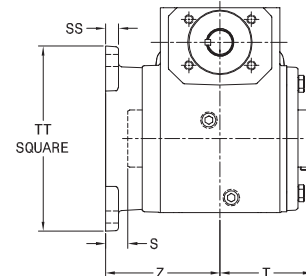
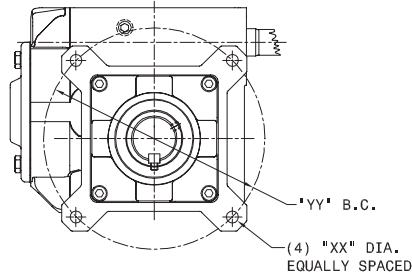

Note: Flange Kit can be installed on either side.

F-Flange Kits

MODEL	F-FLANGE KIT NO.	SHIPPING WT. LBS.	SIZE REF.	S	T	Z	SS	TT	XX	YY
HERA35	0259-00141	8	18	0.44	2.75	3.19	0.38	5.00	0.34	5.88
	0259-00142	10	21	0.81	2.75	3.56	0.44	6.00	0.41	7.00
	0259-00143	10	24	0.75	2.75	3.50	0.44	6.27	0.41	7.50
HERA45	0259-00088	10	24	0.76	3.13	3.88	0.44	6.27	0.41	7.50
	0259-00089	12	26	0.31	3.13	3.44	0.50	6.67	0.41	8.00
HERA55	0259-00090	14	30	0.15	3.13	3.28	0.50	7.37	0.41	9.00
	0259-00123	15	32	0.04	3.75	3.79	0.50	7.37	0.41	9.00
HERA75	0259-00124	20	42	0.34	3.75	4.09	0.62	9.65	0.56	11.5
	0259-00157	20	42	0.31	4.75	5.06	0.62	9.65	0.56	11.5
	0259-00158	25	52	0.71	4.75	4.46	0.75	11.75	0.69	14.00
	0259-00166	30	60	1.82	4.75	6.57	0.75	SPEC	0.69	15.63

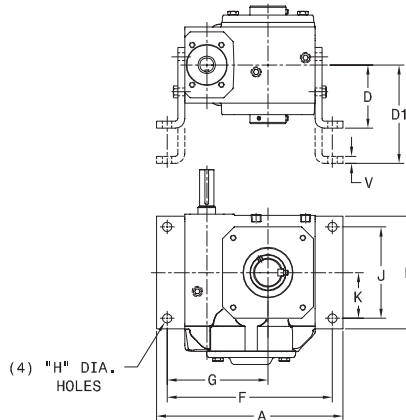

Vertical Base Kits

MODEL	VERTICAL BASE KIT NO.	SHIPPING WT. LBS.	A	B	D	D1	F	G	H	J	K	V
HERA35	0259-00159	7	8.25	5	3	4.38	7.37	4.5	0.44	4	2	0.25
HERA45	0259-00106	10	9.94	6	3.38	5.25	8.81	5.38	0.5	4.88	2.44	0.38
HERA55	0259-00160	15	13	9	4.69	6.25	11.88	7.13	0.56	6.13	3.06	0.38
HERA75	0259-00161	35	16.26	10	5	7.5	14.88	8.69	0.69	7.88	3.94	0.5

Output Bushing Kits for HERA35 and HERA45

BUSHING KIT NO.	BORE SIZE ITEM #1	KEY ITEM #2	KEY ITEM #3	SET SCREWS ITEM #4
0259-00178	3/4	3/8 x 1/4 x 3	3/16 x 3/16 x 3	1/4-20 X 5/8
0259-00179	7/8	3/8 x 1/4 x 3	3/16 x 3/16 x 3	1/4-20 X 1/2
0259-00180	1	3/8 x 1/4 x 3	1/4 x 1/4 x 3	1/4-20 X 1/2
0259-00181	1-1/8	3/8-1/4 STEP x 3	N/A	1/4-20 X 1/2
0259-00182	1-3/16	3/8-1/4 STEP x 3	N/A	1/4-20 X 3/8
0259-00183	1-1/4	3/8-1/4 STEP x 3	N/A	1/4-20 X 3/8

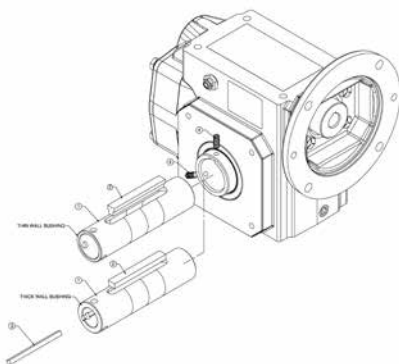

Output Bushing Kits provide a means to adapt the Stock Bore hollow bore diameter to the most popular shaft diameters on driven equipment. Quick and easy installation. Bushing Kits fit both Models HERA35 and HERA45. Note: 1.438" stock bore required.

DIMENSIONS SHOWN ARE FOR REFERENCE ONLY.

DOWNLOAD AVAILABLE CAD MODELS AT: WWW.HUBCITYINC.COM

Hub City HERA® - High-Efficiency Right Angle Gear Drives

Accessories

Riser Block Kits



Riser Block Kits provide a clear top mounting surface above the motor flange for mounting below machine framework etc. Kits include T-base plates and mounting hardware.

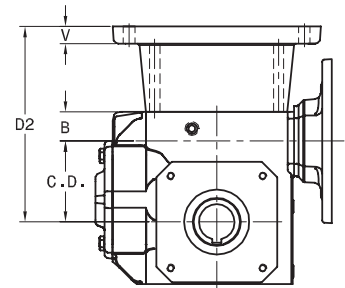
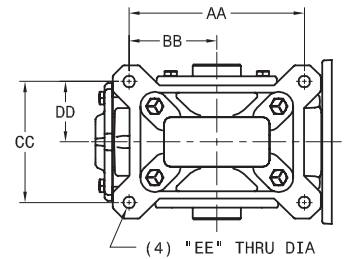

MODEL	KIT NO.	SHIPPING WT. LBS.	SIZE REF.	C.D.	B	D2	V	AA	BB	CC	DD	EE
HERA35	0259-00170	6.2	17	2.509	1.178	5.99	0.63	5.75	2.88	4.5	2.25	0.41
	0259-00171	6.8	20			6.24	0.66	6.38	3.19	4.69	2.34	0.47
	0259-00172	13.1	23			7.88	0.69	7.06	3.53	4.88	2.44	0.47
HERA45	0259-00173	12.2	23	3.263	1.175	7.88	0.69	7.06	3.53	4.88	2.44	0.47
	0259-00174	14.5	26			8.21	0.69	8.00	4.00	5.25	2.63	0.53
	0259-00175	18.0	30			8.63	0.69	8.44	4.22	5.88	2.94	0.53
HERA55	0259-00176	20.0	35	3.675	2.200	9.27	0.81	9.50	4.75	6.13	3.06	0.53
	0259-00177	32.0	40			10.83	0.94	11.13	5.56	7.63	3.81	0.66

Nema 'C' Flange Adaptor Kits

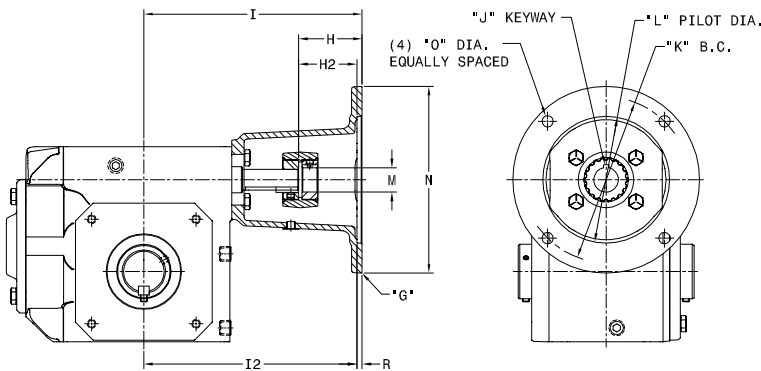

MODEL	BASE UNIT REQUIRED	C-FLANGE KIT NO.	SHIPPING WT. LBS.	G	H	H2	I	I2	J	K	L	M	N	O	R
HERA35	AS24	0259-00079	12	56C	2.25	N/A	7.57	N/A	3/16 X 3/32	5.875	4.501/4.503	.625	6.63	13/32	.188
		0259-00080	14	143TC								.875			
HERA45	AS24	0259-00079	12	56C	2.25	N/A	7.76	N/A	3/16 X 3/32	5.875	4.501/4.503	.625	6.63	13/32	.188
		0259-00080	14	143TC								.875			
		0259-00081	20	182TC								N/A			
HERA55	AS32	0259-00108	12	56C	2.25	N/A	9.00	N/A	3/16 X 3/32	5.875	4.501/4.503	.625	6.50	13/32	.188
		0259-00109	14	143TC								.875			
		0259-00110	20	182TC	N/A	3.25	N/A	10.00	1/4 X 1/8	7.250	8.501/8.503	1.125	9.00	17/32	.188
		0259-00111	20	213TC					5/16 X 5/32			1.375			
HERA75	AS32	0259-00108	12	56C	2.25	N/A	9.88	N/A	3/16 X 3/32	5.875	4.501/4.503	.625	6.63	13/32	.188
		0259-00109	14	143TC								.875			
		0259-00110	20	182TC	N/A	3.34	N/A	10.88	1/4 X 1/8	7.250	8.501/8.503	1.125	9.00	17/32	.188
		0259-00111	20	213TC					5/16 X 5/32			1.375			



Select hollow output bore models in this product line are now available with the HubLoc™ Keyless Bushing System. Refer to pages i and ii at front of this catalog for features, available sizes, and ordering information.

Hub City HERA® - High-Efficiency Right Angle Gear Drives

Accessories & Engineering Info

Torque Arm Kits

MODEL	TORQUE ARM KIT NO.	A	D	KIT SHIPPING WT. LBS.
HERA35	0259-00125	2.50	2.062	8.5
HERA45	0259-00078	3.25	2.500	9.0
HERA55	0259-00107	5.00	3.500	11
HERA75	0259-00144	5.00	4.438	13

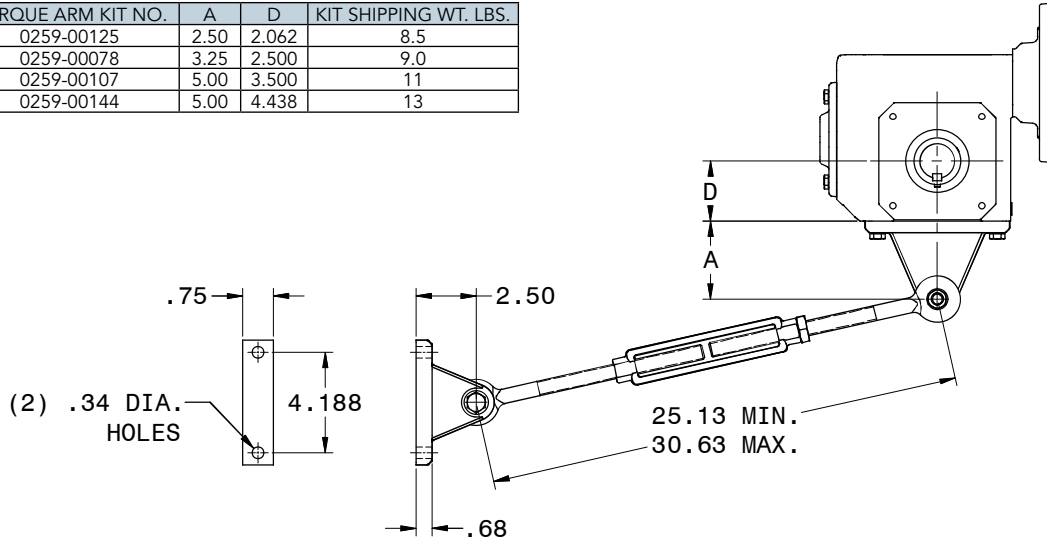

HERA® Engineering Information

MODEL	OVERHUNG LOAD (LBS)*	THRUST LOAD (LBS)
HERA35	1500	1150
HERA45	1800	2100
HERA55	2200	2575
HERA75	3000	3400

MODEL	NORMAL BACKLASH			
	INCHES AT .75" RADIUS OF OUTPUT		ARC-MINUTES	
	MIN	MAX	MIN	MAX
All Models	0.002	0.006	9.2	27.5

*OHL Assumptions:
 1) Load located at 1.5" from end of output sleeve (all models).
 2) These values only account for bearing ratings and do not include stresses on plug-in or customer shafts used with the gear drive unit.
 Consult factory if OHL is expected to exceed above ratings.

HERA® Allowable Mounting Orientation (without factory modification)

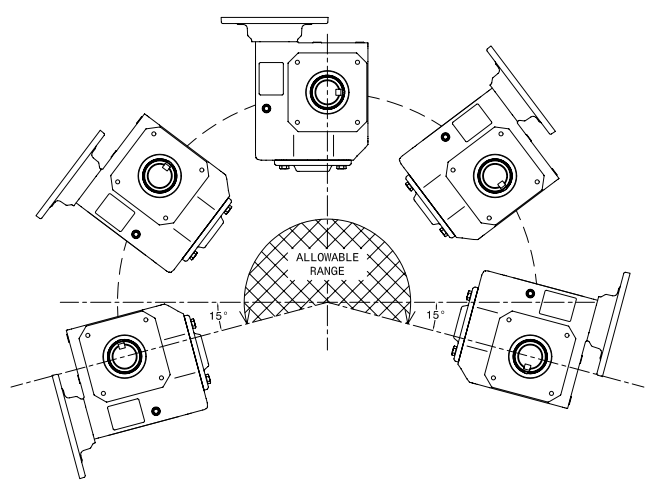

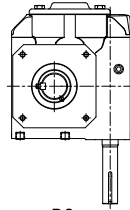

HERA®
Special Mounting
Orientations Requiring
Factory Modification

B6
-INPUT VERTICAL/DOWN-
OUTPUT HORIZONTAL
NOT RECOMMENDED POSITION
(FACTORY MODIFICATIONS REQUIRED)

FILL & BREATHER

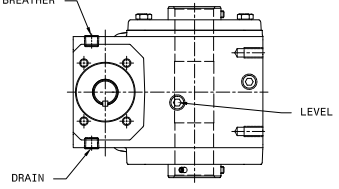

V5
-OUTPUT VERTICAL, COVER SIDE UP-
INPUT HORIZONTAL
(FACTORY MODIFICATIONS REQUIRED)

FILL & BREATHER

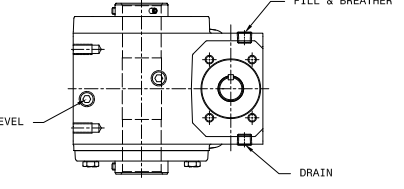

V6
-OUTPUT VERTICAL, COVER SIDE DOWN-
INPUT HORIZONTAL
(FACTORY MODIFICATIONS REQUIRED)

Hub City HERA® - High-Efficiency Right Angle Gear Drives

Helical-HERA® Compound Speed Reducer Assemblies

A Helical Ratio Multiplier when coupled with a C-faced HERA® Gear Drive (see illustration) can create an efficient compound speed reducer assembly. Please refer to rating chart example below for selection instructions.

Note: See page F-7 for dimensions and available frame sizes of Helical Ratio Multipliers and page H-6 for dimensions and available frame sizes of HERA® models. Units to be ordered separately. Also see section F for ratings of Helical Ratio Multipliers as stand alone Parallel Shaft Reducers.

Mechanical Ratings

RATINGS @ 1750 RPM INPUT, 1.00 SERVICE FACTOR

Use charts below when coupling a Helical Ratio Multiplier with a HERA® gear drive.

TOTAL RATIO	OUTPUT RPM	HERA® MODEL	HERA® RATIO	RM RATIO	INPUT HP	OUTPUT TORQUE
1. Select Total Ratio desired			7.33	2. Select by Input HP or Output Tq required for your application		
75.25	23.3	HERA55	15.05	4.000	1.08	2,600
78.00	22.4	HERA45	19.50	4.000	0.45	1,100
79.72	22.0	HERA35	19.93	7.182	0.44	1,100
82.02	21.3	HERA35	11.42			

3. Order C-face model of HERA® model and ratio listed here (see page H-7)

4. Order ARM1X model and ratio listed here

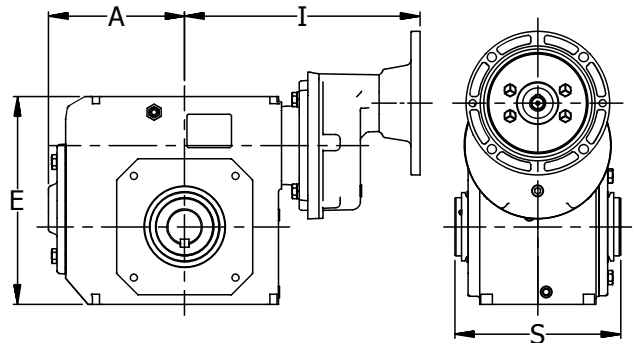

HERA® MODEL	HELICAL RATIO MULTIPLIER MODEL	A	E	I	S
HERA35	ARM1XQ	4.25	5.750	9.50	5.50
HERA45	ARM1XQ	4.88	6.938	9.69	6.25
HERA55	ARM1XQ	6.15	9.375	10.63	7.50
HERA75	ARM1XQ	8.36	11.375	11.51	9.50

NOTE: **INPUT** FRAME SIZE OF HERA® gear drive **MUST** match **OUTPUT** frame size of Helical Ratio Multiplier (see dimensional pages referenced for available frame sizes).

TOTAL RATIO	OUTPUT RPM	HERA® MODEL	HERA® RATIO	RM RATIO	INPUT HP	OUTPUT TORQUE
79.72	22.0	HERA35	19.93	4.000	0.45	1,100
82.02	21.3	HERA35	11.42	7.182	0.44	1,100
84.77	20.6	HERA35	29.10	2.913	0.42	1,100
87.06	20.1	HERA35	43.53	2.000	0.41	1,100
99.65	17.6	HERA35	19.93	5.000	0.36	1,100
105.00	16.7	HERA35	52.50	2.000	0.34	1,100
112.04	15.6	HERA35	15.60	7.182	0.32	1,100
116.40	15.0	HERA35	29.10	4.000	0.31	1,100
126.80	13.8	HERA35	43.53	2.913	0.28	1,100
145.50	12.0	HERA35	29.10	5.000	0.25	1,100
152.93	11.4	HERA35	52.50	2.913	0.23	1,100
169.92	10.3	HERA35	58.33	2.913	0.21	1,100
174.12	10.1	HERA35	43.53	4.000	0.21	1,100
210.00	8.3	HERA35	52.50	4.000	0.17	1,100
217.65	8.0	HERA35	43.53	5.000	0.16	1,100
233.32	7.5	HERA35	58.33	4.000	0.15	1,100
262.50	6.7	HERA35	52.50	5.000	0.14	1,100
291.65	6.0	HERA35	58.33	5.000	0.12	1,100
312.63	5.6	HERA35	43.53	7.182	0.11	1,100
377.06	4.6	HERA35	52.50	7.182	0.09	1,100
418.93	4.2	HERA35	58.33	7.182	0.09	1,100
78.00	22.4	HERA45	19.50	4.000	1.08	2,600
97.50	17.9	HERA45	19.50	5.000	0.87	2,600
105.00	16.7	HERA45	52.50	2.000	0.80	2,600
112.04	15.6	HERA45	28.01	4.000	0.75	2,600
112.04	15.6	HERA45	15.60	7.182	0.75	2,600
116.46	15.0	HERA45	39.98	2.913	0.73	2,600
119.58	14.6	HERA45	59.79	2.000	0.71	2,600
140.05	12.5	HERA45	28.01	5.000	0.60	2,600
152.93	11.4	HERA45	52.50	2.913	0.55	2,600
159.92	10.9	HERA45	39.98	4.000	0.53	2,600
174.17	10.0	HERA45	59.79	2.913	0.48	2,600
199.90	8.8	HERA45	39.98	5.000	0.42	2,600
210.00	8.3	HERA45	52.50	4.000	0.40	2,600
239.16	7.3	HERA45	59.79	4.000	0.35	2,600
262.50	6.7	HERA45	52.50	5.000	0.32	2,600
287.14	6.1	HERA45	39.98	7.182	0.29	2,600
298.95	5.9	HERA45	59.79	5.000	0.28	2,600
377.06	4.6	HERA45	52.50	7.182	0.22	2,600
429.41	4.1	HERA45	59.79	7.182	0.20	2,600

TOTAL RATIO	OUTPUT RPM	HERA® MODEL	HERA® RATIO	RM RATIO	INPUT HP	OUTPUT TORQUE
75.25	23.3	HERA55	15.05	5.000	1.94	4,500
84.60	20.7	HERA55	21.15	4.000	1.73	4,500
87.80	19.9	HERA55	30.14	2.913	1.66	4,500
106.06	16.5	HERA55	53.03	2.000	1.38	4,500
108.09	16.2	HERA55	15.05	7.182	1.35	4,500
117.84	14.9	HERA55	58.92	2.000	1.24	4,500
120.56	14.5	HERA55	30.14	4.000	1.21	4,500
128.08	13.7	HERA55	43.97	2.913	1.14	4,500
150.70	11.6	HERA55	30.14	5.000	0.97	4,500
154.48	11.3	HERA55	53.03	2.913	0.95	4,500
171.63	10.2	HERA55	58.92	2.913	0.85	4,500
175.88	9.9	HERA55	43.97	4.000	0.83	4,500
212.12	8.3	HERA55	53.03	4.000	0.69	4,500
216.47	8.1	HERA55	30.14	7.182	0.68	4,500
219.85	8.0	HERA55	43.97	5.000	0.66	4,500
235.68	7.4	HERA55	58.92	4.000	0.62	4,500
265.15	6.6	HERA55	53.03	5.000	0.55	4,500
294.60	5.9	HERA55	58.92	5.000	0.50	4,500
315.79	5.5	HERA55	43.97	7.182	0.46	4,500
380.86	4.6	HERA55	53.03	7.182	0.38	4,500
423.16	4.1	HERA55	58.92	7.182	0.35	4,500
74.66	23.4	HERA75	37.33	2.000	3.70	8,500
84.60	20.7	HERA75	21.15	4.000	3.26	8,500
87.80	19.9	HERA75	30.14	2.913	3.14	8,500
106.06	16.5	HERA75	53.03	2.000	2.60	8,500
108.74	16.1	HERA75	37.33	2.913	2.54	8,500
117.84	14.9	HERA75	58.92	2.000	2.34	8,500
120.56	14.5	HERA75	30.14	4.000	2.29	8,500
149.32	11.7	HERA75	37.33	4.000	1.85	8,500
150.70	11.6	HERA75	30.14	5.000	1.83	8,500
151.90	11.5	HERA75	21.15	7.182	1.82	8,500
154.48	11.3	HERA75	53.03	2.913	1.79	8,500
171.63	10.2	HERA75	58.92	2.913	1.61	8,500
186.65	9.4	HERA75	37.33	5.000	1.48	8,500
212.12	8.3	HERA75	53.03	4.000	1.30	8,500
216.47	8.1	HERA75	30.14	7.182	1.28	8,500
235.68	7.4	HERA75	58.92	4.000	1.17	8,500
265.15	6.6	HERA75	53.03	5.000	1.04	8,500
268.10	6.5	HERA75	37.33	7.182	1.03	8,500
294.60	5.9	HERA75	58.92	5.000	0.94	8,500
380.86	4.6	HERA75	53.03	7.182	0.72	8,500
423.16	4.1	HERA75	58.92	7.182	0.65	8,500

Output TQ measured in IN-LB.

NOTE: All Ratios Will Backdrive due to High Efficiency Gearing

Hub City HERA® - High-Efficiency Right Angle Gear Drives

Double HERA® Speed Reducer Power Ratings

Speed Reducer Assemblies

1750 RPM INPUT (1.0 SF), 80% EFFICIENCY AT RATED TORQUE*

HERA3535

TOTAL RATIO	PRIMARY RATIO	SEC. RATIO	OUTPUT RPM	INPUT HP	OUTPUT TQ
91.6	8.02	11.42	19.1	0.41	1,100
125.1	8.02	15.60	14.0	0.30	1,100
130.4	11.42	11.42	13.4	0.29	1,100
159.8	8.02	19.93	10.9	0.24	1,100
178.2	11.42	15.60	9.8	0.21	1,100
243.4	15.60	15.60	7.2	0.15	1,100
310.9	15.60	19.93	5.6	0.12	1,100
332.3	11.42	29.10	5.3	0.11	1,100
349.1	8.02	43.53	5.0	0.11	1,100
397.2	19.93	19.93	4.4	0.09	1,100
421.1	8.02	52.50	4.2	0.09	1,100
454.0	15.60	29.10	3.9	0.08	1,100
467.8	8.02	58.33	3.7	0.08	1,100
497.1	11.42	43.53	3.5	0.08	1,100
599.6	11.42	52.50	2.9	0.06	1,100
679.1	15.60	43.53	2.6	0.06	1,100
819.0	15.60	52.50	2.1	0.05	1,100
867.6	19.93	43.53	2.0	0.04	1,100
909.9	15.60	58.33	1.9	0.04	1,100
1046.3	19.93	52.50	1.7	0.04	1,100
1162.5	19.93	58.33	1.5	0.03	1,100
1266.7	29.10	43.53	1.4	0.03	1,100
1527.8	29.10	52.50	1.1	0.02	1,100
1697.4	29.10	58.33	1.0	0.02	1,100
1894.9	43.53	43.53	0.9	0.02	1,100
2285.3	43.53	52.50	0.8	0.02	1,100
2539.1	43.53	58.33	0.7	0.01	1,100
2756.3	52.50	52.50	0.6	0.01	1,100
3062.3	52.50	58.33	0.6	0.01	1,100
3402.4	58.33	58.33	0.5	0.01	1,100

HERA4535

TOTAL RATIO	PRIMARY RATIO	SEC. RATIO	OUTPUT RPM	INPUT HP	OUTPUT TQ
91.1	8.02	11.36	19.2	0.98	2,600
125.1	8.02	15.60	14.0	0.71	2,600
156.4	8.02	19.50	11.2	0.57	2,600
178.2	11.42	15.60	9.8	0.50	2,600
243.4	15.60	15.60	7.2	0.37	2,600
304.2	15.60	19.50	5.8	0.29	2,600
320.6	8.02	39.98	5.5	0.28	2,600
421.1	8.02	52.50	4.2	0.21	2,600
456.6	11.42	39.98	3.8	0.20	2,600
494.5	43.53	11.36	3.5	0.18	2,600
558.2	19.93	28.01	3.1	0.16	2,600
599.6	11.42	52.50	2.9	0.15	2,600
682.8	11.42	59.79	2.6	0.13	2,600
796.8	19.93	39.98	2.2	0.11	2,600
819.0	15.60	52.50	2.1	0.11	2,600
932.7	15.60	59.79	1.9	0.10	2,600
1046.3	19.93	52.50	1.7	0.09	2,600
1163.4	29.10	39.98	1.5	0.08	2,600
1191.6	19.93	59.79	1.5	0.07	2,600
1527.8	29.10	52.50	1.1	0.06	2,600
1739.9	29.10	59.79	1.0	0.05	2,600
2285.3	43.53	52.50	0.8	0.04	2,600
2602.7	43.53	59.79	0.7	0.03	2,600
2756.3	52.50	52.50	0.6	0.03	2,600
3139.0	52.50	59.79	0.6	0.03	2,600
3487.6	58.33	59.79	0.5	0.03	2,600

HERA5535

TOTAL RATIO	PRIMARY RATIO	SEC. RATIO	OUTPUT RPM	INPUT HP	OUTPUT TQ
86.4	8.02	10.77	20.3	1.79	4,500
120.7	8.02	15.05	14.5	1.28	4,500
169.6	8.02	21.15	10.3	0.91	4,500
241.7	8.02	30.14	7.2	0.64	4,500
299.9	19.93	15.05	5.8	0.51	4,500
329.9	15.60	21.15	5.3	0.47	4,500
344.2	11.42	30.14	5.1	0.45	4,500
352.6	8.02	43.97	5.0	0.44	4,500
425.3	8.02	53.03	4.1	0.36	4,500
502.1	11.42	43.97	3.5	0.31	4,500
605.6	11.42	53.03	2.9	0.25	4,500
672.9	11.42	58.92	2.6	0.23	4,500
827.3	15.60	53.03	2.1	0.19	4,500
876.3	19.93	43.97	2.0	0.18	4,500
919.2	15.60	58.92	1.9	0.17	4,500
1056.9	19.93	53.03	1.7	0.15	4,500
1174.3	19.93	58.92	1.5	0.13	4,500
1279.5	29.10	43.97	1.4	0.12	4,500
1543.2	29.10	53.03	1.1	0.10	4,500
1714.6	29.10	58.92	1.0	0.09	4,500
1914.0	43.53	43.97	0.9	0.08	4,500
2308.4	43.53	53.03	0.8	0.07	4,500
2564.8	43.53	58.92	0.7	0.06	4,500
2784.1	52.50	53.03	0.6	0.06	4,500
3093.3	52.50	58.92	0.6	0.05	4,500
3436.8	58.33	58.92	0.5	0.04	4,500

HERA7535

TOTAL RATIO	PRIMARY RATIO	SEC. RATIO	OUTPUT RPM	INPUT HP	OUTPUT TQ
109.4	11.42	9.58	16.0	2.66	8,500
120.7	8.02	15.05	14.5	2.41	8,500
149.4	15.60	9.58	11.7	1.95	8,500
169.6	8.02	21.15	10.3	1.72	8,500
241.7	8.02	30.14	7.2	1.21	8,500
299.4	8.02	37.33	5.8	0.97	8,500
344.2	11.42	30.14	5.1	0.85	8,500
425.3	8.02	53.03	4.1	0.69	8,500
472.5	8.02	58.92	3.7	0.62	8,500
503.0	52.50	9.58	3.5	0.58	8,500
605.6	11.42	53.03	2.9	0.48	8,500
672.9	11.42	58.92	2.6	0.43	8,500
744.0	19.93	37.33	2.4	0.39	8,500
827.3	15.60	53.03	2.1	0.35	8,500
877.1	29.10	30.14	2.0	0.33	8,500
919.2	15.60	58.92	1.9	0.32	8,500
1056.9	19.93	53.03	1.7	0.28	8,500
1174.3	19.93	58.92	1.5	0.25	8,500
1543.2	29.10	53.03	1.1	0.19	8,500
1714.6	29.10	58.92	1.0	0.17	8,500
1959.8	52.50	37.33	0.9	0.15	8,500
2308.4	43.53	53.03	0.8	0.13	8,500
2564.8	43.53	58.92	0.7	0.11	8,500
2784.1	52.50	53.03	0.6	0.10	8,500
3093.3	52.50	58.92	0.6	0.09	8,500
3436.8	58.33	58.92	0.5	0.08	8,500

*Estimated - Actual may vary depending on application conditions

Output TQ measured in IN-LB.

Other total ratios available, consult factory.

NOTE: All Ratios Will Backdrive due to High Efficiency Gearing

Hub City HERA® - High-Efficiency Right Angle Gear Drives

Double HERA® Speed Reducers

Series: HERA3535, HERA4535, HERA5535, & HERA7535

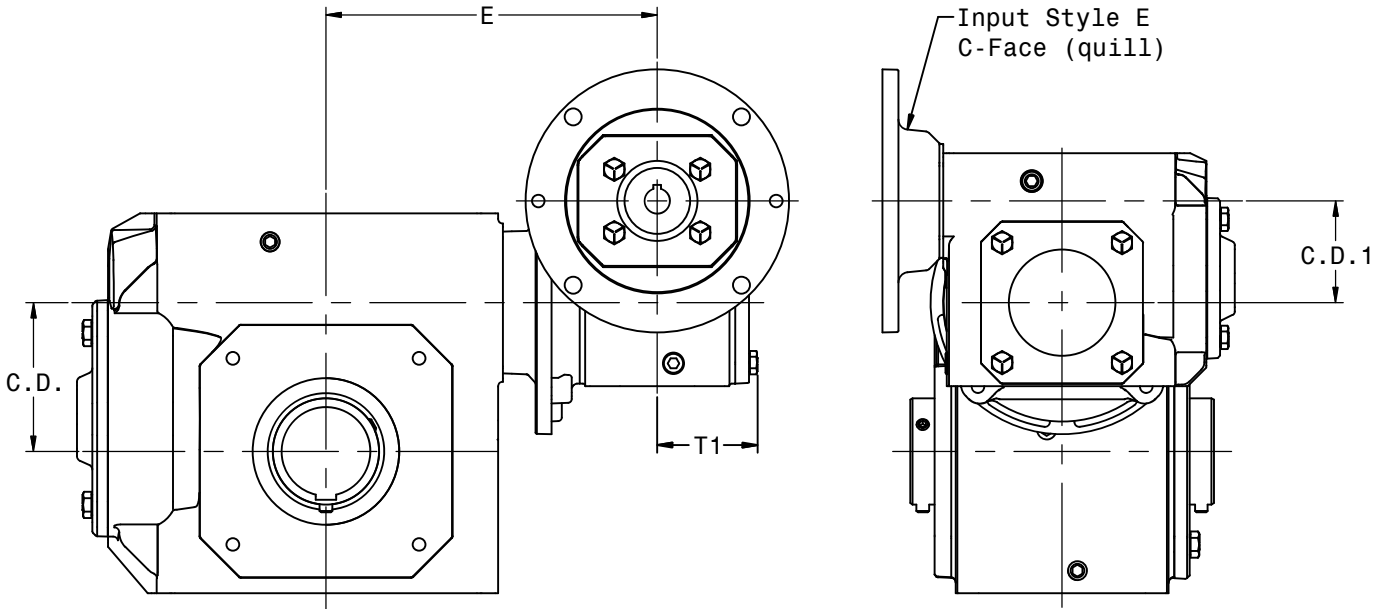

SERIES	PRIMARY	SECONDARY	C.D.	C.D. 1	E	T1
HERA3535	HERA35	HERA35	2.509	2.509	7.05	2.48
HERA4535	HERA35	HERA45	3.263	2.509	7.24	2.48
HERA5535	HERA35	HERA55	3.675	2.509	8.18	2.48
HERA7535	HERA35	HERA75	4.287	2.509	9.06	2.48

REFER TO PAGE H6 FOR ALL OTHER DIMENSIONS.

DIMENSIONS SHOWN ARE FOR REFERENCE ONLY.
 DOWNLOAD AVAILABLE CAD MODELS AT: WWW.HUBCITYINC.COM

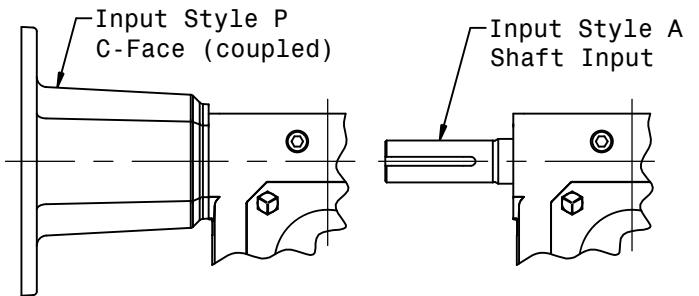

Standard Styles Available

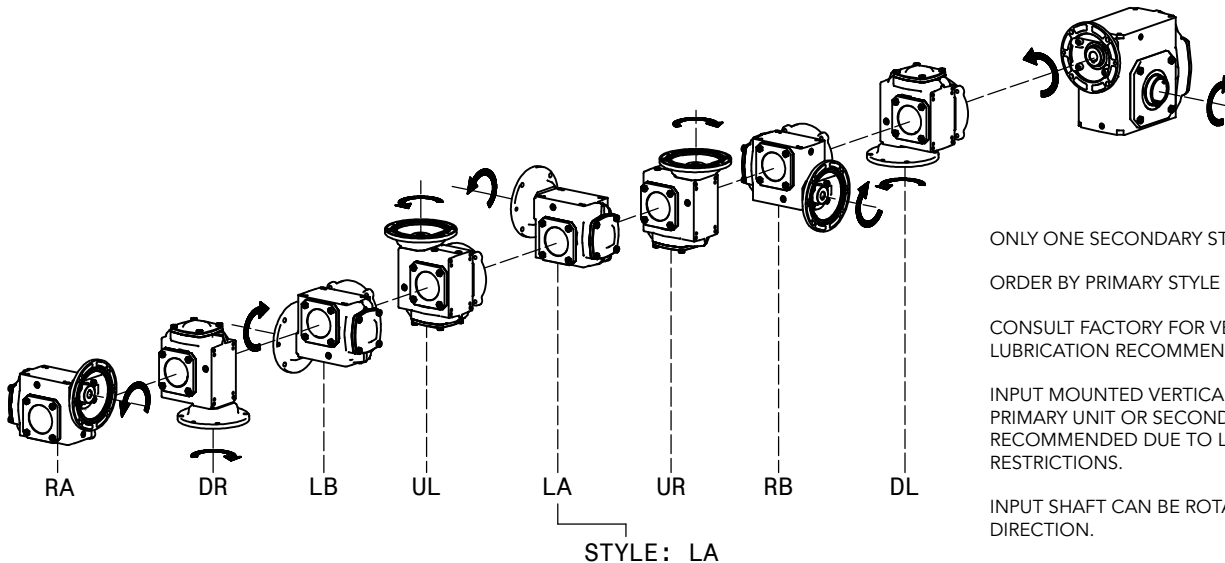

ONLY ONE SECONDARY STYLE AVAILABLE.

ORDER BY PRIMARY STYLE ONLY.

CONSULT FACTORY FOR VERTICAL SHAFT LUBRICATION RECOMMENDATIONS.

INPUT MOUNTED VERTICAL/DOWN ON PRIMARY UNIT OR SECONDARY UNIT IS NOT RECOMMENDED DUE TO LUBRICATION RESTRICTIONS.

INPUT SHAFT CAN BE ROTATED IN EITHER DIRECTION.

Hub City HERA® - High-Efficiency Right Angle Gear Drives

Worm Reducer Interchange

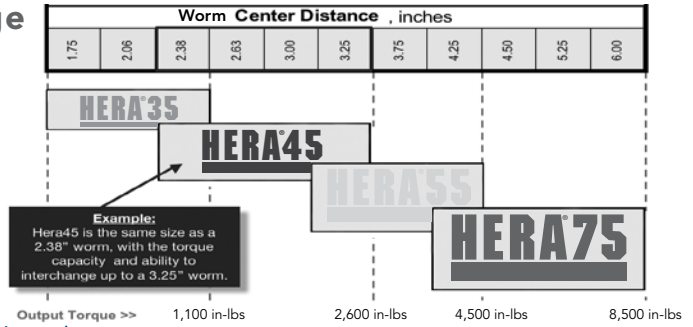

Competitor Interchange Guide

Solid Output Shaft-NEMA C Flange Reducer (Quill Input)

CENTER DIST. (in.)	1.75	2.06	2.38	2.62	3.00	3.25	3.75	4.25	5.25	6.00
HERA - ES w/plug-in shaft kit	Hera35ES	Hera35ES*	Hera35ES*			Hera55ES	Hera55ES*	Hera55ES*		
BALDOR	F918	F921	F924	F926	F930	F932	F938	—	—	—
BOSTON	F718	F721	F724	F726	F730	F732	F738	—	F752	F760
Dodge-Tigear-2	17Q	20Q	23Q	26Q	30Q	—	35Q	40Q	47Q	
Falk-Omnibox	1175WBM	1206WBM	1238WBM	1262WBM	1300WBM	1325WBM	—	1425WBM	1525WBM	1600WBM
Morse-Raider	175Q	206Q	237Q	262Q	300Q	325Q	375Q	450Q	516Q	600Q

Solid Output Shaft-NEMA C Flange Reducer (Coupled Input)

CENTER DIST. (in.)	1.75	2.06	2.38	2.62	3.00	3.25	3.75	4.25	5.25	6.00
HERA - PS w/plug-in shaft kit	Hera35PS	Hera35PS*	Hera35PS*			Hera55PS	Hera55PS*	Hera55PS*		
BALDOR	LF918	LF921	LF924	LF926	LF930	LF932	LF938	—	—	—
BOSTON	RF718	RF721	RF724	RF726	RF730	RF732	RF738	—	RF752	RF760
Dodge-Tigear-2	17A	20A	23A	26A	30A	—	35A	40A	47A	
Falk-Omnibox	1175WBF	1206WBF	1238WBF	1262WBF	1300WBF	1325WBF	—	1425WBF	1525WBF	1600WBF
Morse-Raider	175C	206C	237C	262C	300C	325C	375C	450C	516C	600C

Solid Output Shaft-Non-Flanged Reducer (Basic Unit)

CENTER DIST. (in.)	1.75	2.06	2.38	2.62	3.00	3.25	3.75	4.25	5.25	6.00
HERA - AS w/plug-in shaft kit	Hera35AS	Hera35AS*	Hera35AS*			Hera55AS	Hera55AS*	Hera55AS*		
BALDOR	S918	S921	S924	S926	S930	S932	S938	—	S952	S960
BOSTON	718	721	724	726	730	732	738	—	752	760
Dodge-Tigear-2	17S	20S	23S	26S	30S	—	35S	40S	47S	
Falk-Omnibox	1175WB	1206WB	1238WB	1262WB	1300WB	1325WB	—	1425WB	1525WB	1600WB
Morse-Raider	175U	206U	237U	262U	300U	325U	375U	450U	516U	600U

Hollow Output Shaft-NEMA C Flange Reducer (Quill Input)

CENTER DIST. (in.)	1.75	2.06	2.38	2.62	3.00	3.25	3.75	4.25	5.25	6.00
HERA - ES	Hera35ES	Hera35ES*	Hera35ES*			Hera55ES	Hera55ES*	Hera55ES*		
BALDOR	HF918	HF921	HF924	HF926	HF930	HF932	HF938	—	—	—
BOSTON	HF718	HF721	HF724	HF726	HF730	HF732	HF738	—	—	—
Dodge-Tigear-2	17QH	20QH	23QH	26QH	30QH	—	35QH	40QH	47QH	
Falk-Omnibox	1175WBQM	1206WBQM	—	1262WBQM	1300WBQM	1325WBQM	—	1425WBQM	1525WBQM	1600WBQM
Morse-Raider	175QH	206QH	237QH	262QH	300QH	325QH	375QH	450QH	516QH	600QH

Hollow Output Shaft-NEMA C Flange Reducer (Coupled Input)

CENTER DIST. (in.)	1.75	2.06	2.38	2.62	3.00	3.25	3.75	4.25	5.25	6.00
HERA - PS	Hera35PS	Hera35PS*	Hera35PS*			Hera55PS	Hera55PS*	Hera55PS*		
BALDOR	HLF918	HLF921	HLF924	HLF926	HLF930	HLF932	HLF938	—	—	—
BOSTON	HRF718	HRF721	HRF724	HRF726	HRF730	HRF732	HRF738	—	—	—
Dodge-Tigear-2	17AH	20AH	23AH	26AH	30AH	—	35AH	40AH	47AH	
Falk-Omnibox	1175WBQF	1206WBQF	—	1262WBQF	1300WBQF	1325WBQF	—	1425WBQF	1525WBQF	1600WBQF
Morse-Raider	175CH	206CH	237CH	262CH	300CH	325CH	375CH	450CH	516CH	600CH

Hollow Output Shaft - Non-Flanged Reducer (Basic Unit)

CENTER DIST. (in.)	1.75	2.06	2.38	2.62	3.00	3.25	3.75	4.25	5.25	6.00
HERA - AS	Hera35AS	Hera35AS*	Hera35AS*			Hera55AS	Hera55AS*	Hera55AS*		
BALDOR	HS918	HS921	HS924	HS926	HS930	HS932	HS938	—	—	—
Boston	H718	H721	H724	H726	H730	H732	H738	—	—	—
Dodge-Tigear-2	17SH	20SH	23SH	26SH	30SH	—	35SH	40SH	47SH	
Falk-Omnibox	1175WBQ	1206WBQ	1238WBQ	1262WBQ	1300WBQ	1325WBQ	—	1425WBQ	1525WBQ	1600WBQ
Morse-Raider	175UH	206UH	237UH	262UH	300UH	325UH	375UH	450UH	516UH	600UH

*B-Interchange Base Kit required for foot mounting (see accessory page H-7)
 Information for reference only, consult factory for information on your specific application.