

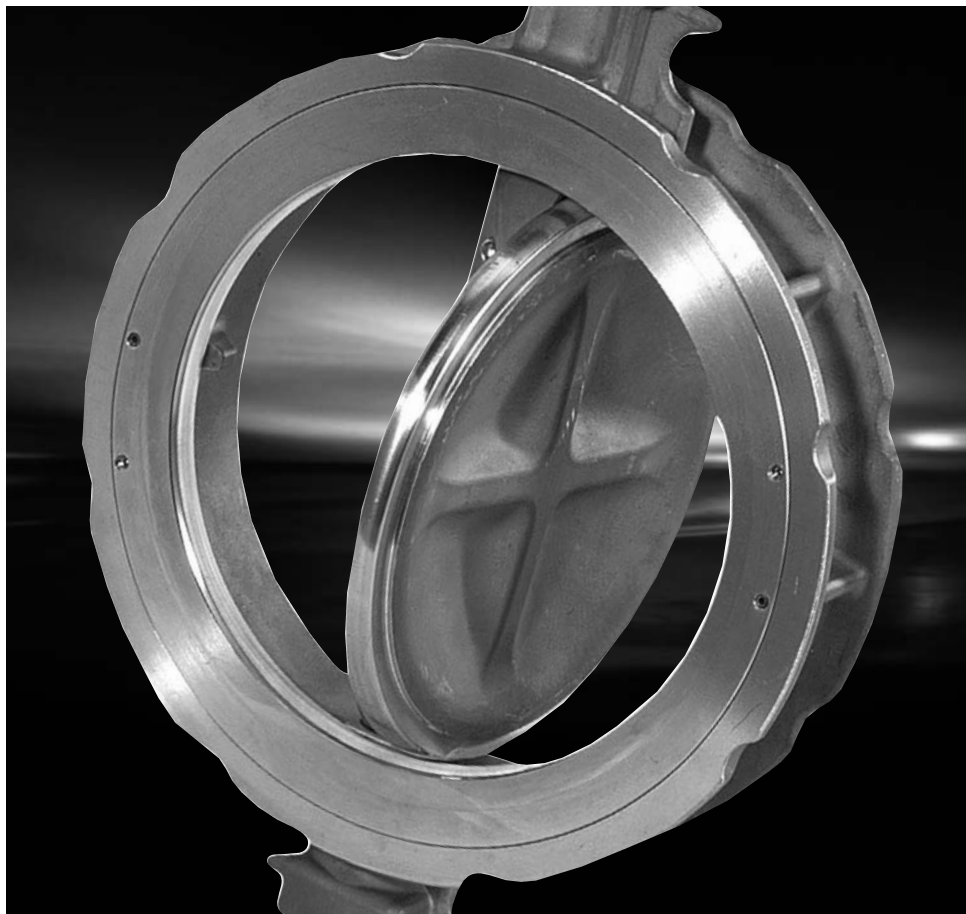

# High Performance Butterfly Valves



**Handling Manual**

## Read This Instruction Manual Carefully Before Using High Performance Butterfly Valves

This instruction manual shows how to use High Performance Butterfly Valves.  
For proper use, be sure to read this instruction manual carefully.

# Note

## Warranty Period

Our products are guaranteed for either a period of 18 months from shipment out of our factory or 12 months from trial operation, whichever is the shorter.

## Charged Repair and Parts Supply For Discontinued Production

Products will be discontinued or replacement without any notification.  
Regarding discontinued production or sales, after five years from its discontinuance, please be informed we could not meet your request of repair or overhaul in some cases.

## Extents of guarantee and exemption

When a breakdown occurs due to our responsibility during a period guaranteed above, an exchange or a repair of a part damaged of the product will be done without charge at a place of the product purchased only inland of Japan.

However some cases mentioned below will be charged.

- Case of breakdown by unacceptable condition, circumstances, handling and using except confirmation by catalogues, handling notes or application forms exchanged especially and etc.
- Case breakdown is caused by excepting delivered product.
- Case of breakdown by reconstruction or repair except our hand.
- Case of breakdown using under condition not given as a design application condition of valves or circumstances not foreseen through condition given.
- Case of completely worn out of sheetring, grandpacking and etc.
- Case of a bad supply condition of articles for consumption like lubricating oil and etc.
- Case of breakdown due to unfitting conservation inspection by movements opening shutting frequently.
- Case of breakdown due to electric and air switches.
- Case of breakdown due to flaw and bite of foreigners such as dusts to products.
- Case of breakdown due to unsuitable storage of products outside.
- Case of breakdown due to natural disasters such as fire, water, earthquake, falling stones and so on.
- Case of breakdown due to not responsibility by us.

Besides, guarantee mentioned here is the one of single product delivered.

## ● Contents

Before Using	1
Structural Drawing	2
Stocking, Handling, Un-packing	4
Piping Work 1-Cares Before Installation Valve To Piping	5
Piping Work 2-Cares After Installation Valve To Piping	7
Check-up, Maintenance 1-Periodic Check-up, Removal From Piping	9
Check-up, Maintenance 2 -Exchange The Seat-ring	1 0
Check-up, Maintenance 3-Exchange The Grand Packing · Gasket	1 1
Check-up, Maintenance 4 -Removing The Actuator	1 3
Check-up, Maintenance 5 -Set The Actuator	1 4
Trouble Shooting-For Valve Body Trouble	1 5
Trouble Shooting-For Actuator Trouble	1 7

# Structural Drawing

## 5410 Series

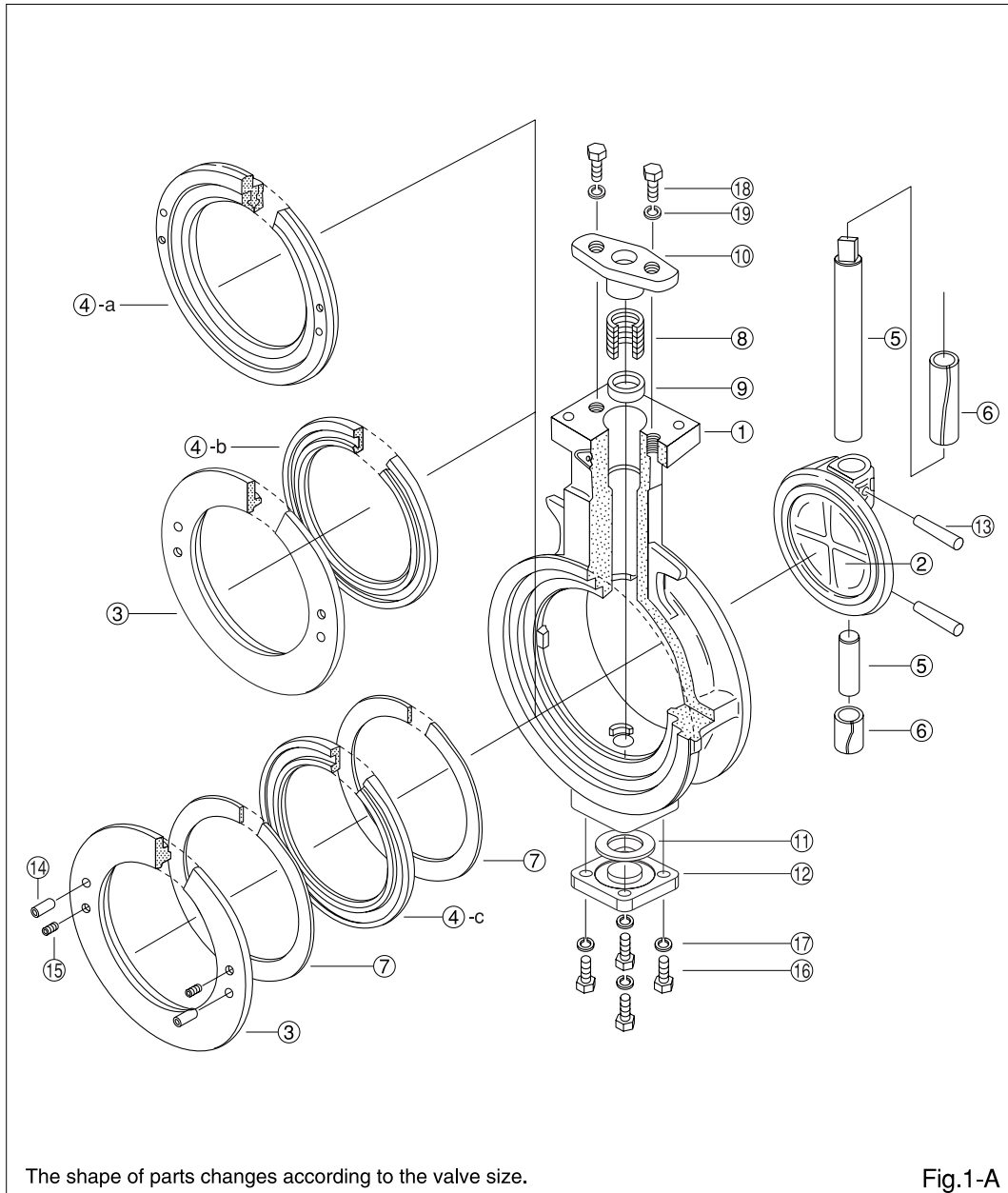

No.	Parts Name	Q'ty	No.	Parts Name	Q'ty
①	Body	1	⑨	Packing Washer	1
②	Disc	1	⑩	Gland	1
③	Set-Ring	1	⑪	Gasket	1
④-a	Lower Seat-Ring	541R	⑫	Cover	1
④-b	PTFE Seat-Ring	541T	⑬	Taper pin	1set
④-c	SUS316 Seat-Ring	541M	⑭	Set pin	2
⑤	Stem	1set	⑮	Set Screw	2
⑥	Bushing	1set	⑯	Cover Bolt	4
⑦	Gasket	2	⑰	Spring Washer	4
⑧	Gland Packing	1set	⑱	Spring Washer	2

# Structural Drawing

## 5400 Series

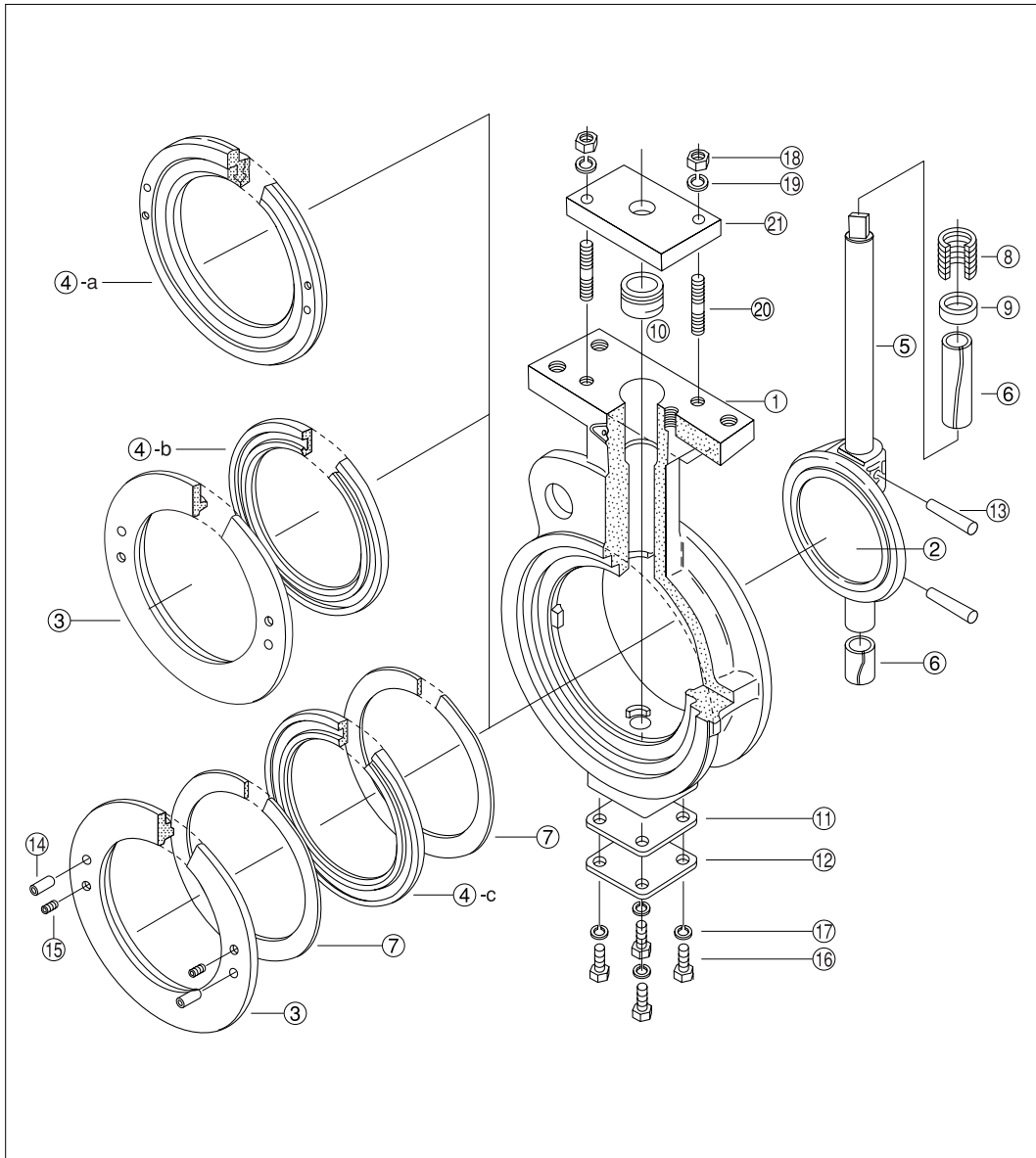

The shape of parts changes according to the valve size.

Fig.1-B

No.	Parts Name	Q'ty	No.	Parts Name	Q'ty
①	Body	1	⑪	Gasket	1
②	Disc	1	⑫	Cover	1
③	Set-Ring	1	⑬	Taper pin	2
④-a	Lower Seat-Ring	5421	⑭	Set pin (50mm~300mm)	1set
④-b	PTFE Seat-Ring	5422		Set Screw (350mm~600mm)	1set
④-c	SUS316 Seat-Ring	5423	⑮	Set Screw	2
⑤	Stem	1	⑯	Cover Bolt	4
⑥	Bushing	2	⑰	Spring Washer	4
⑦	Gasket	2	⑱	Gland Bolt	2
⑧	Gland Packing	1set	⑲	Spring Washer	2
⑨	Packing Washer	1	⑳	Gland Bolt and Nut	2
⑩	Gland	1	㉑	Gland Flange	1

# Stocking, Handling, Un-packing

● Protect valve from vibration, dust, sudden rise or fall in temperature.

● As for the explanation, 5410 series are the main.

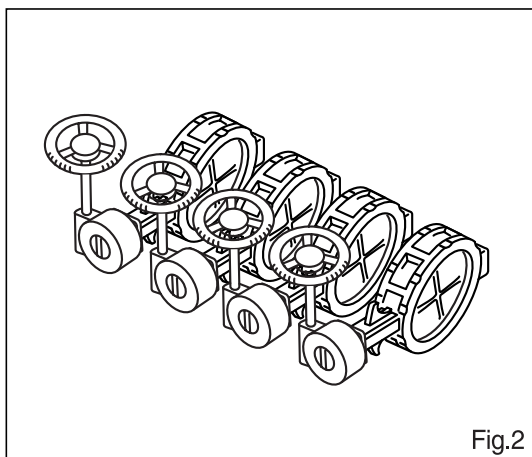

Fig.2

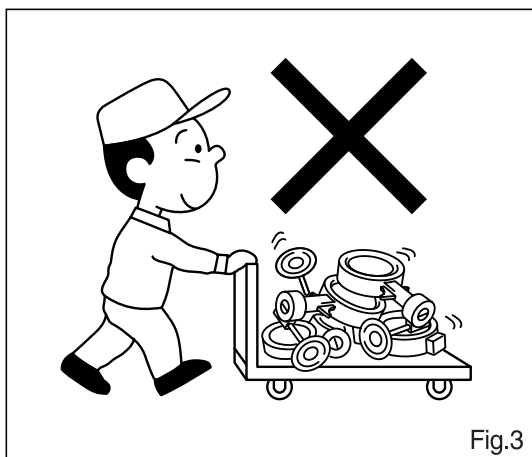

Fig.3

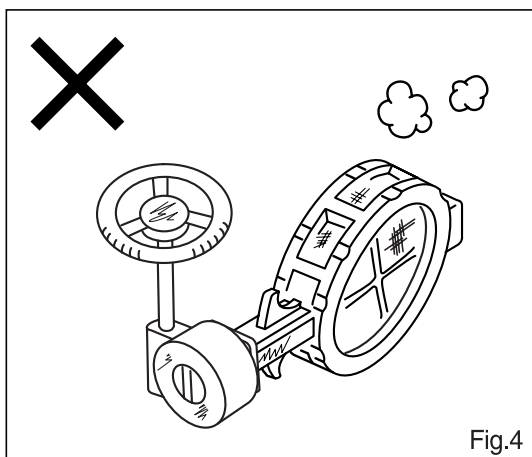

Fig.4

## 1, Stocking

- **Stocking(packed)** : Valve to kept/stored indoors under cool and dark condition(temp:  $-5^{\circ}\text{C} \sim 60^{\circ}\text{C}$ , humidity: less than 70%), if valve not installed to pipings immediately after delivery.
- **Stocking(un-packed)** : When valve to be stored without packing, any excessive force to its actuator part to be avoided. Cover-sheet to be put onto valve at dusty place. (Fig.2)
- **Stocking** : Apply anti-rust to the plated-parts(indicators, bolts nuts worm shafts, etc...) once a year if valve is stored for one year or longer.

## 2, Handling

- **Cares while handling** : When valve to be kept/stored under packed condition, package(s) to be put on stable place so that collapse of package(s) to be avoided. Upon carriage, valve to be nicely loaded so that any collapse to valve could be avoided. When valve to be carried after removing packing, excessive force to valve to be avoided and cover-sheet to be put onto valve in dusty-place.(Fig.3)
- **Trucking** : To use truck with canopy is recommended if possible. Cover valve to prevent dust if a truck with no canopy is used.
- **Sipping(seaborne)** : Use a container for shipping to protect valve from sea breeze. Sea breeze will damage valve.

## 3, Un-packing

- **Un-packing** : Un-packing of valve to be recommended before its installation to pipings. If valve stored being unpacked for long, dust or foreign matter will get into the valve. If will cause malfunctions. (Fig.4)
- **Check disc position** : Make sure if valve is in the closed position when package is opened.

# Piping Work 1

## Cares Before Installation Valve To Piping

- Clean valve body, flanges, pipings, carefully before installation procedures to pipings.

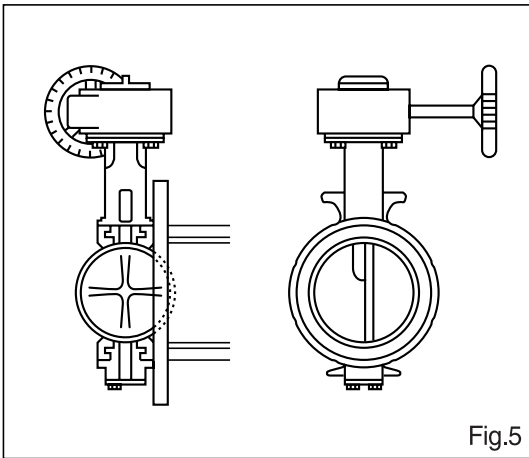

### 1, Checking Valve Body

- **Check sizes and material** : Sizes & Specifications of Trim Materials are indicated on package and valve, and re-confirmation of sizes/specifications before its installation to pipings is recommended.
- **Check piping sizes** : Check the valve sizes fit the piping sizes. (Fig.5)
- **Check the number and the sizes of bolts** : Before using bolts and nuts, apply a seizure preventive to bolts and nuts.

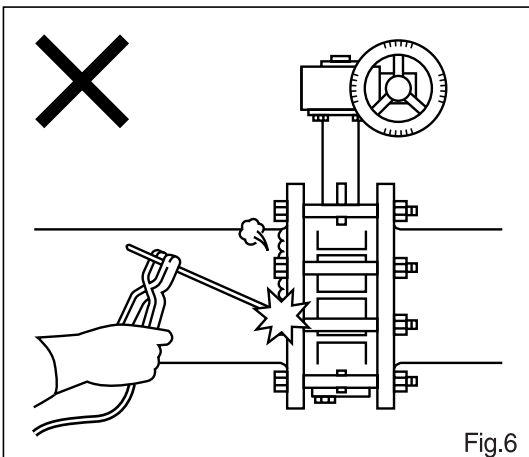

### 2, Welding Before Installation To Piping

- **Cares when welding flanges** : Installation of the valve immediately after welding of the flange to be avoided, and installation to be made only after welded-part cooled down.  
Welding of flange or repairing works through welding, while keeping the valve installed to pipings, to be avoided. (Fig.6)  
Make sure welding work is completely done before installation the valve to the piping. Flanges to check and confirm on deflection or miscenter-alignment of flange and no spatter stuck.

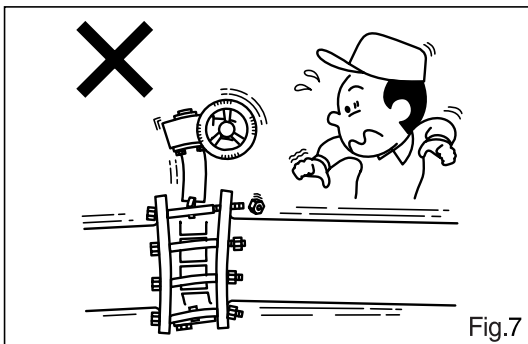
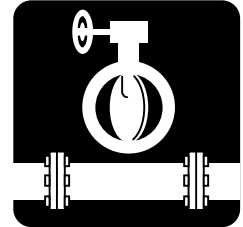

Fig.7

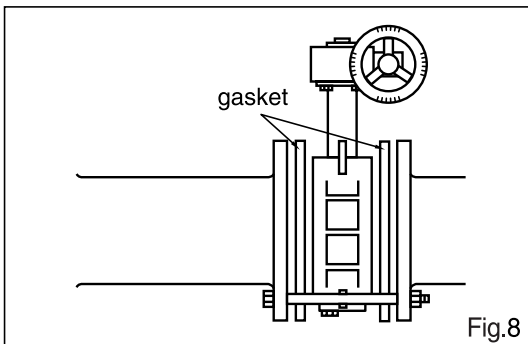

Fig.8

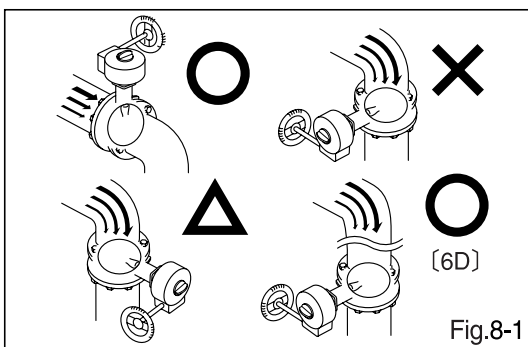

Fig.8-1

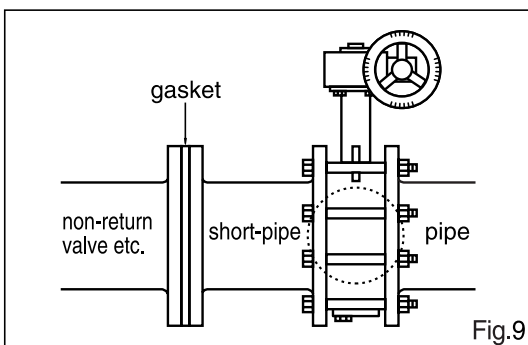

Fig.9

### 3, Check Piping Flanges

- **Make sure no deflection or damage to piping** : Make sure no deflection or miscenter-alignment of flanges and no score or spatter stacked. Clean spatter stacked on the edge of the flanges completely in order not to damage the seat-ring.
- **Cleaning** : Flange surface is to be air-purged for cleaning. If rust or foreign matter is sticking on the surface of the flanges, wash the surface of the flanges in detergent. After washing, make sure no detergent remains on the seat-ring. If detergent remains on the seat-ring, it will damage the seat-ring. Make sure that no oil or detergent sticks to EPDM seat.

### 4, Cares Before Installation Valve To Piping

- **Installation place** : Application to heavy-vibrant positions to be avoided. To keep enough space for maintenance work. (Fig.7)
- **Installation work** : Connect the valve and the piping flanges correctly. Forcing the valve to insert between the piping flanges to be avoided.
- **Gasket packing** : The insertion between the valve and the piping-flanges shall be needed the gaskets. In inserting, adjust both the valve and the gasket to the center of the flanges accurately. Keep space of about 3mm to 5mm between the valve to the piping-gasket (the flanges) on each side. (Fig.8) Do not insert the valve between the piping flanges forcefully. And also, do not use the flexible material such as rubber to the gasket, otherwise, we recommend the joint seat as the piping-gasket. Further, in using the special gasket such as the spiral gasket, please contact to sales person in charge.
- **Disc position** : Keep the valve in closed position when installation to the pipings.
- **Installation the valve to a bent pipe** : Upon installation of the valve to the pipings, no define limitation of direction of the valve being installed but, under such condition as illustrated in Fig.8-1, direction of stem to be cared.
- **Installation the valve to a return valve to a return valve, etc...** : When the valve to be installed directly to return valve, pumps, etc..., there may be cases in which disc touches to other upon its full opening. In this case, short-pipe to be fixed before installation of the valve. (Fig.9)

# Piping Work 2

## Cares After Installation Valve To Pipings

● Read the procedures shown under carefully.

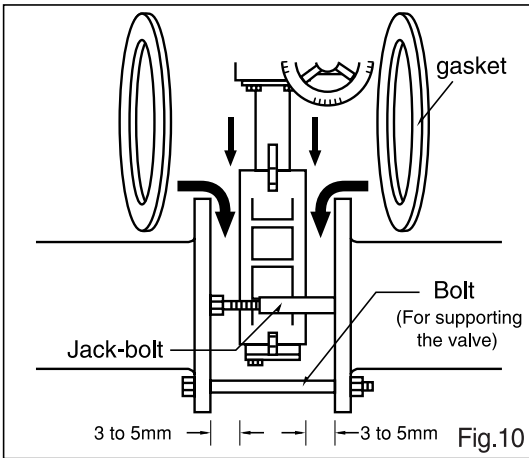

### 1, Installation Procedures To Pipings

1. **Cleaning** : Remove foreign matter from part of the valve touches surface of flanges by air blow.
2. **Check the valve position** : Make sure the disc is in the closed position.
3. **Suspend (Support) the valve** : Insert bolts into lower flange holes, and then put nuts on either side of the bolts to support the valve.
4. **Set jack bolts** : Keep space of about 3mm to 5mm between the valve and the flanges on each side.(Fig.10)
5. **Insert the valve** : Do not insert the valve between the piping flanges forcefully.
6. **Center the valve to the piping flanges** : Insert bolts into the flange holes to suspend the valve, then center the valve to the flanges accurately.
7. **Tighten up bolts** : Firstly, as Fig.10-1 (top and bottom), tighten the bottom of the bolt A and B not to drop the valve. Then insert other bolts. (Fig.10-1)  
Tightening piping bolts is doing evenly and diagonally. Unbalanced fastening among bolts causes any leakage. From 1 to 8 is shown example of the order of fastening bolts. (Fig.10-2)
8. **Check the disc movement** : After installation of the valve, operate the valve ( from/to open and close) to make sure the disc dose not touch any part of the pipings.

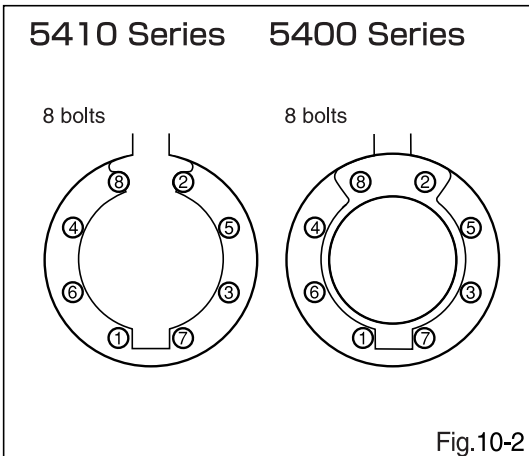
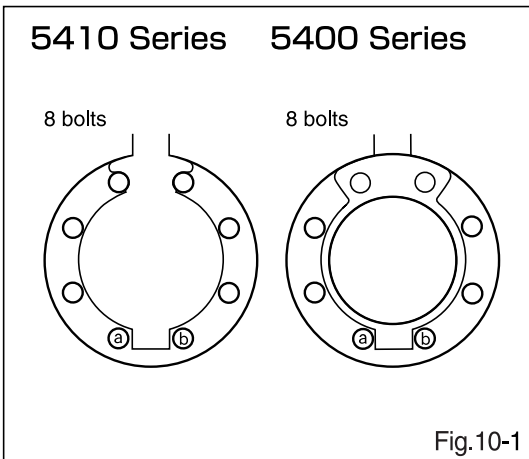

- ※In case of that flow medium is steam, install the stem side as the upstream of flow direction.
- ※Regarding Model 541R and 541M, install the stem side as the upstream of flow direction.



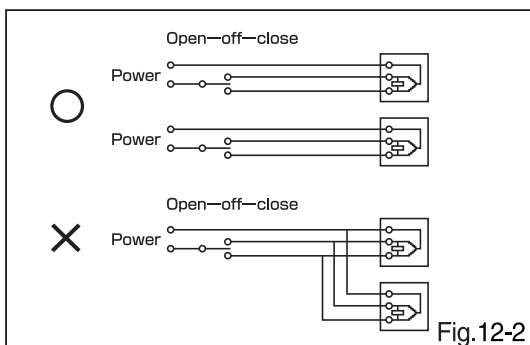
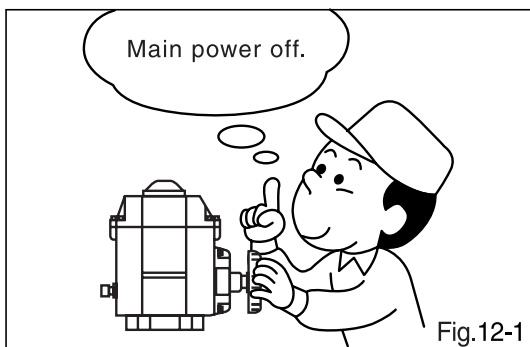
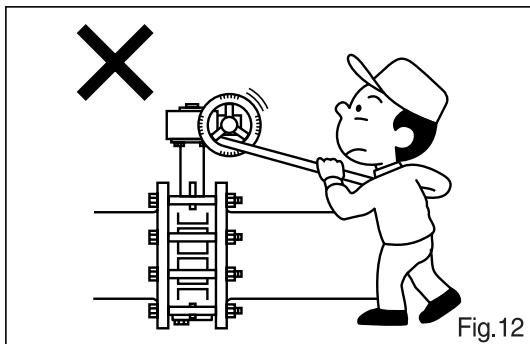
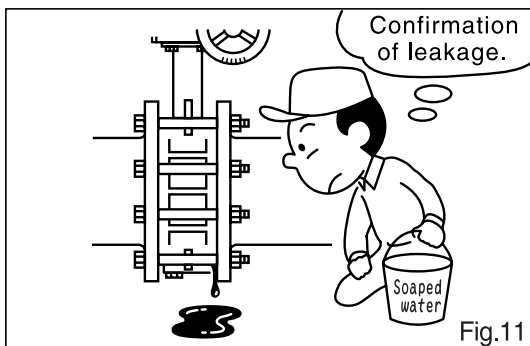
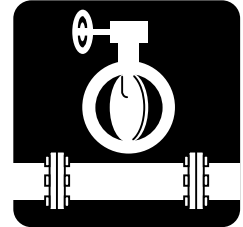

## 2, Cares After Installation to Pippings

- **Check leakage** : Before operation of the valve, pressure inside the pippings to be raised and to make sure no-leakage between the piping-flanges and the valve. When gas used as fluid, use soaped water for checking leakage. However, pressure inside the pippings not to be raised beyond the valve specifications, and set the disc of the valve in the open position while checking the leakage. (Fig.11)
- **Treatment for leakage** : In case of leakage, reduce the pressure firstly, and then tightening the flange bolt again. Tightening bolts is doing evenly and diagonally. Unbalanced fastening among bolts causes any eakage.

## 3, Other Points to be cared

- **Trial run (Check-up run)** : Operate the valve by manual before operating.
- **Cares while operating the valve with a hand wheel** : Be sure to turn the hand wheel by the hand. Do not turn the hand wheel with a wrench or lever in order not to cause trouble. (Fig.12)
- **Do not use blank flange** : Keep the valve fully opened while pressure test, etc. Do not use the fully closed valve as a blind flange.
- **Cares after pippings** : Regarding motorized valve, in operating by manual hand wheel, make sure the main power is off before operating. After returning electric operation mode, remove the lever and put on the main power.(Fig.12-1) Operating more than two actuators by one switch shall cause malfunction due to wrap around circuit. So, Operate one by one, and also, set up the relay nterface. (Fig.12-2)
- **Opening/Closing the valve in short time** causes the water hammer which may damage the valve or the other instrument. Please contact the person in charge if you use such a way.
- **In case that actuator and valve is soused by corrosive fluid directly**, protect with protection cover.
- **In case that control valve is installed to upstream side**, vibration of turbulent may damage it, so get space from 3D to 5D.

# Check-up, Maintenance 1

## — Periodic Check-up, Removal From Piping

● To maintain high operationability and reliability, periodic check-up and maintenance is recommended.

- For large-size valves, fix the valves by a vise.
- Concerning parts number, refer to page 2 and 3.

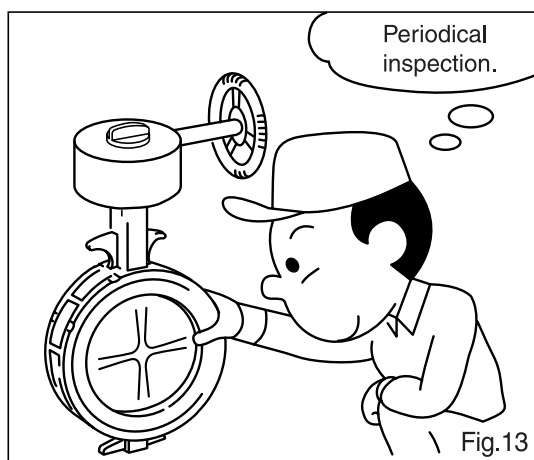
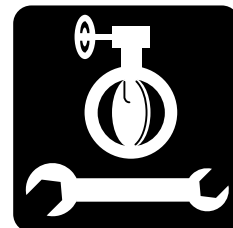

Fig.13

### 1, Checkup

- **Periodic checkup** : Inspect the disc or seat-ring at least once a year. Make sure no disc is corroded or worned. (Fig.13)
- **Long no use after installation** : If the valve is not to be used for extended periods after installation, open and close it manually or automatically at least once two weeks.
- **Trouble happened** : If valve operates improperly, foreign matter or damage to seat-ring or something may be of the cause of the problem. Please see the trouble shooting chart shown in P .15.

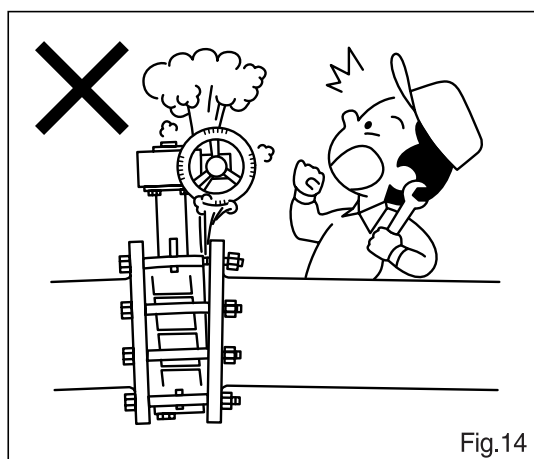

Fig.14

### 2, Removal From Pipings

- **Check pressure inside pipings before removing the valve from pipings** :  
When the valve removes from pipings, make sure the pressure inside the pipings is lowered.  
In case of fluid remaining inside the pipings, drain it out from the pipings. (Fig.14)
- **How to remove the valve from the pipings** : Set the valve in the closed position, then pull out bolts and nuts. In doing this, remain a few bolts and nuts in the lower holes of flanges to support the valve. For easy-removal work, inserting jack bolts is recommended.

# Check-up, Maintenance 2

## — Exchange The Seat-ring

● Refer to the attached structural drawings.

- For large-size valve, fix the valves by vise.
- Concerning parts number, refer to page 2 and 3.

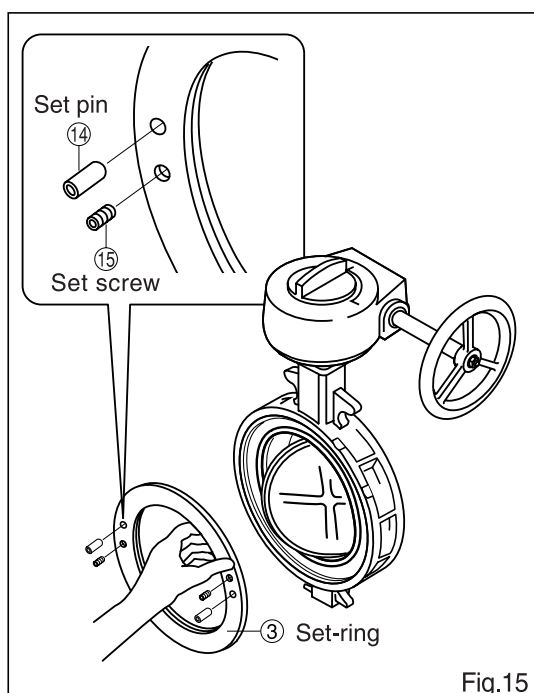
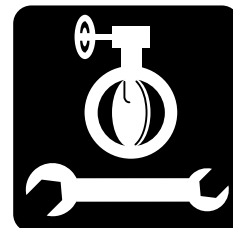

Fig.15

### Disassemble

1. Tighten up the Set screw<sup>15</sup> of the set-ring<sup>3</sup> by wrench, and then pull out the set pin<sup>14</sup> and set-ring<sup>3</sup> (Fig.15)  
※Be careful not to lose the set pin and screw.
2. Regarding PTFE seat, remove the seat-ring<sup>4-b</sup> from the set-ring<sup>3</sup>. Regarding Metal seat, remove the seat-ring<sup>4-c</sup> and the seat gasket<sup>7</sup> from the set-ring.  
(Regarding rubber seat, seat-ring<sup>4-a</sup> and the set-ring<sup>3</sup> is as a unit. (detachable.)

### Assembly

1. Clean the body, Disc and the set-ring.
2. Close the disc fully.
3. Regarding PTFE seat, join the seat-ring<sup>4-b</sup> and the set-ring<sup>3</sup> together, and then put it to the body.  
Regarding Metal seat, sandwich the gasket between the seat-ring<sup>4-b</sup> and set-ring<sup>3</sup>, likewise, sandwich the gasket between the seat-ring and the body.  
(You shall exchange the gasket necessarily.)  
Regarding Rubber seat, the seat-ring<sup>4-a</sup> and the set-ring<sup>3</sup> is a solid part, so put it to the body directly.
4. Tighten up two pieces of the set pins<sup>14</sup> and the set screws<sup>15</sup> to the one side of the front side of the set-ring<sup>3</sup>(total 4 pieces of them to both sides)
5. Make sure that the set screws<sup>15</sup> shall not be stuck out from the set-ring<sup>3</sup>.

# Check-up, Maintenance 3

## — Exchange The Grand Packing · Gasket

● Refer to the attached structural drawings.

- For large-size valve, fix the valves by vise.
- Concerning parts number, refer to page 2 and 3.

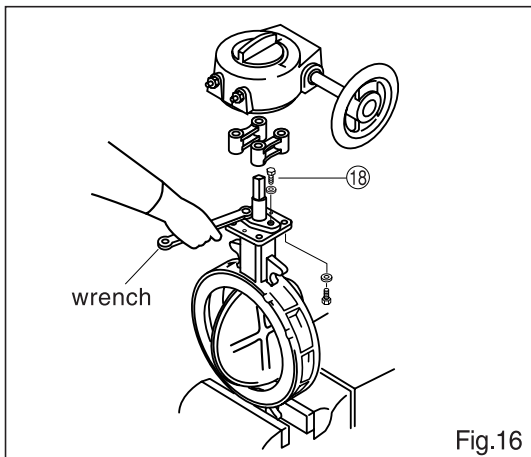

Fig.16

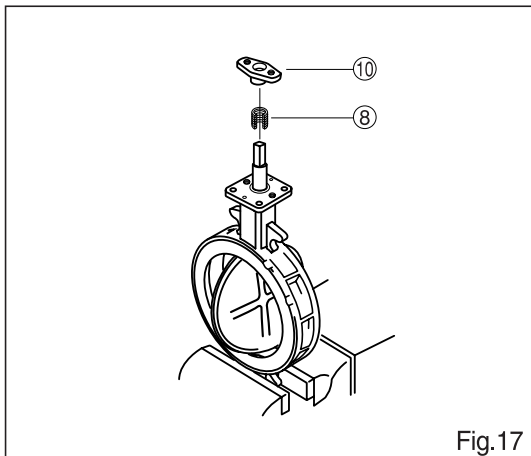
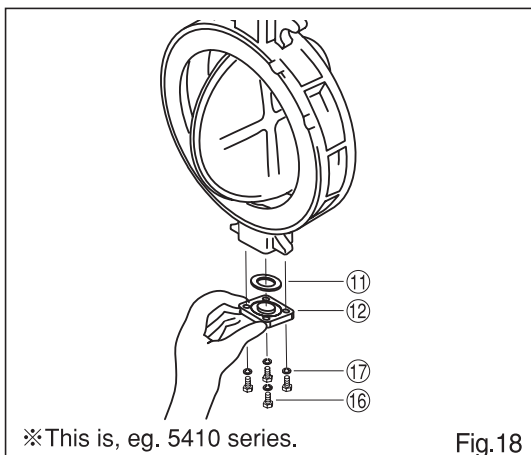

Fig.17



※ This is, eg. 5410 series.

Fig.18

### 1, Disassemble (Fig 16, 17 and 18)

1. It is dangerous for you to disassemble in piping situation, so make sure remove the valve from the piping before working.
2. Remove the actuator from the body.
3. Remove 2 pieces of the Grand bolts<sup>⑩</sup> by a wrench.
4. Remove the Grand retainer.<sup>⑩</sup>
5. Remove the V Packing<sup>⑧</sup>.
6. Clean up the applied part and each pars.
7. Loose 4 cover bolts<sup>⑬</sup> in the cover by wrench and take them out with the spring washer<sup>⑰</sup>.
8. Take out the bottom gasket<sup>⑪</sup> and the cover<sup>⑫</sup>.
9. Clean the cover and clear dusts.

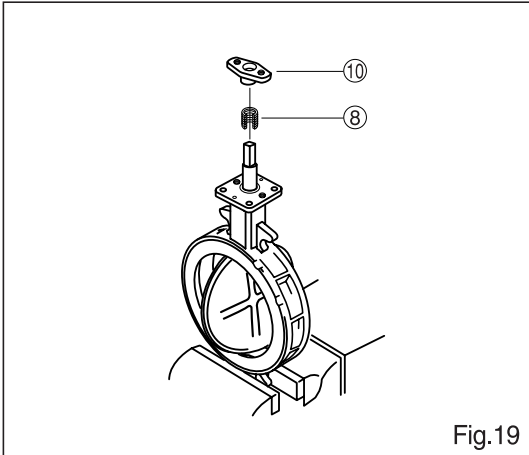

Fig.19

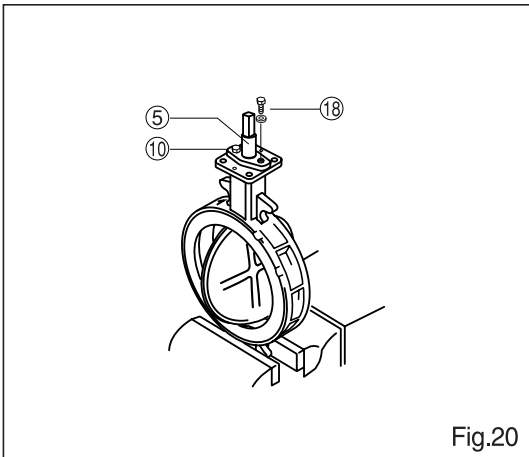

Fig.20

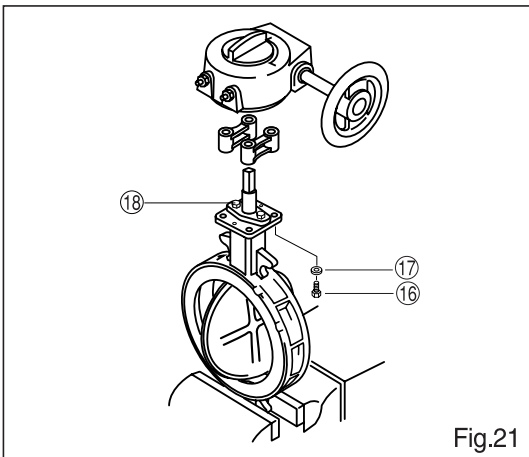
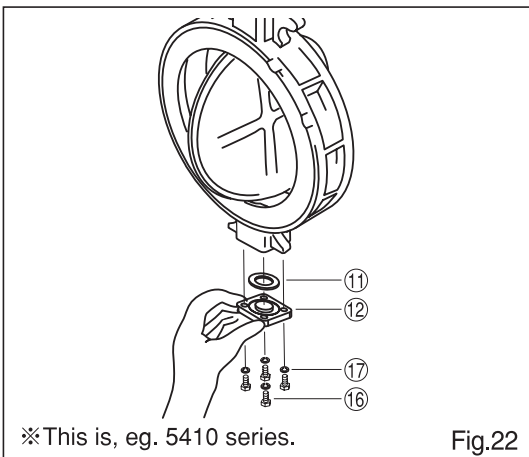

Fig.21



※ This is, eg. 5410 series.

Fig.22

## 2, Setting (Fig.19, 20, 21 and 22)

1. Insert the new V Packing⑧ to the packing hole.  
( In case of vacuum situation, insert it oppositely. )
2. Set the Grand retainer from the stem⑤, and then tighten up the 2 pieces Grand bolts symmetrically.
3. Set the Yoke and the actuator to the body.
4. In case that you have any leakage from the Grand part after exchanging the Grand packing, tighten up the Grand bolts⑩ again.
5. Set the body tightening evenly by the cover bolt⑯ and the spring washer⑰ taken to pieces.
6. Put a new bottom gasket⑪ into a cover⑫.
7. Set the cover⑫ mentioned above into the body, and then tighten evenly by the cover bolt⑯ and the spring washer ⑰.

# Check-up, Maintenance 4

## — Removing The Actuator

● Refer to the attached structural drawings.

● For large-size valves, fix the valves by a vise.

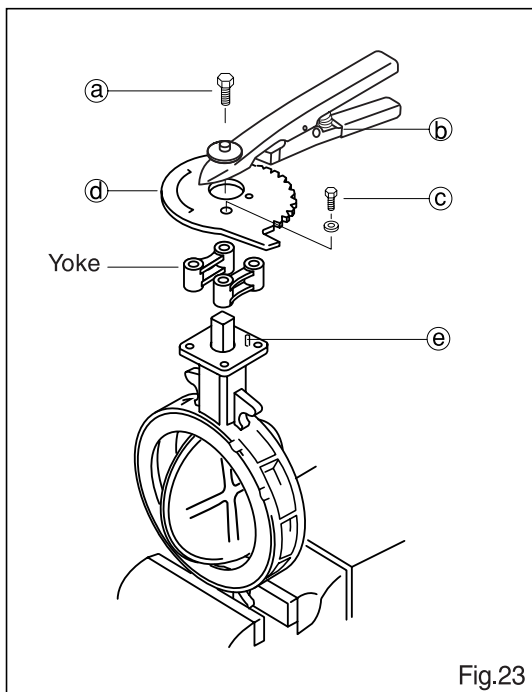

Fig.23

### 1, How to remove the Actuator from the valve

Fix the valve body by a vise before disassembling the valve.

#### 1. Lver type (Fig.23)

1. **Removing the upper bolt** : Remove the bolt-Ⓐ which fixes the name plate of the LeverⒷ.
2. **Removing the Lever** : Hold the lever notch and then hold it up and remove it.
3. **Removing the Indicator** : Remove two boltsⒸ fixes up the indicatorⒹ. And then strike the pinⒺ sets the indicator by the plastic hummer, and remove the pin and the indicator.

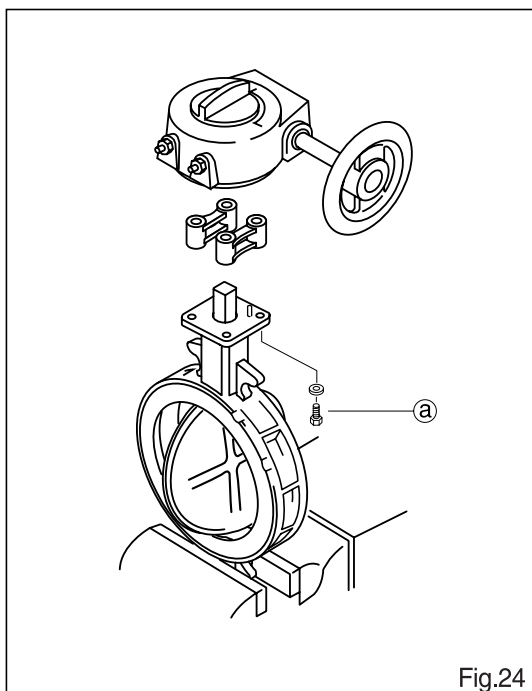

Fig.24

#### 2. Gear type (Fig.24)

1. **Removing the bolt** : Remove the boltⒶ fixes the actuator and the body.
2. **Removing the actuator** : Hold up the actuator and remove it from the body.

※ For air-cylinder or electric motor type, contact your OKM sales representative.

# Check-up, Maintenance 5

## — Set The Actuator

● Refer to the attached structural drawings.

● For large-size valves, fix the valves by a vise.

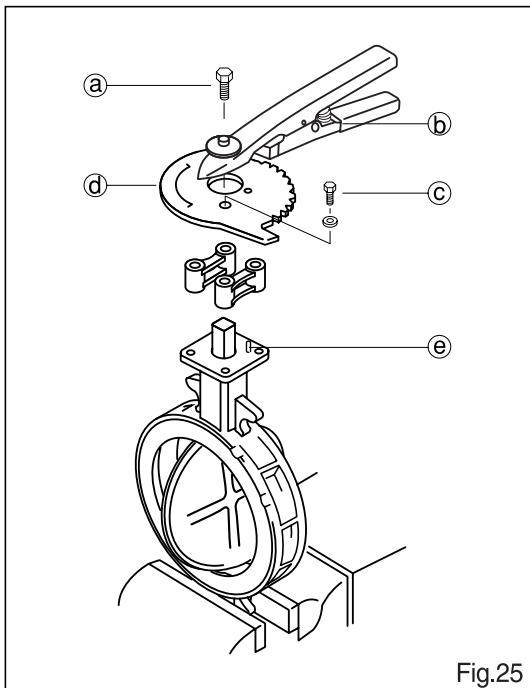
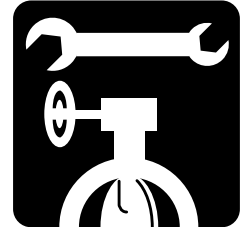

Fig.25

### 1, How to set the actuator on the valve

Fix the valve body by a vise before setting.

#### 1.Lever type (Fig.25)

1. **Check the disc position** : Open the valve fully.
2. **Fix the indicator** : After inserting the pin<sup>Ⓐ</sup> into the hole on the valve neck, put the indicator<sup>Ⓓ</sup> through the pin<sup>Ⓐ</sup>. Then, fix the indicator to the valve body by two bolts<sup>Ⓒ</sup>.
3. **Set the lever** : Set the lever<sup>Ⓒ</sup> to the letter (S) marked on the indicator. And then, fix the name plate to the indicator by the bolt<sup>Ⓐ</sup>.
4. **Check the disc movement** : Turn the lever to make sure if the lever can operate smoothly and the nose of the lever can point at graduation on the indicator<sup>Ⓓ</sup> accurately. After checking the above(lever position), keep the valve in almost fully closed position.

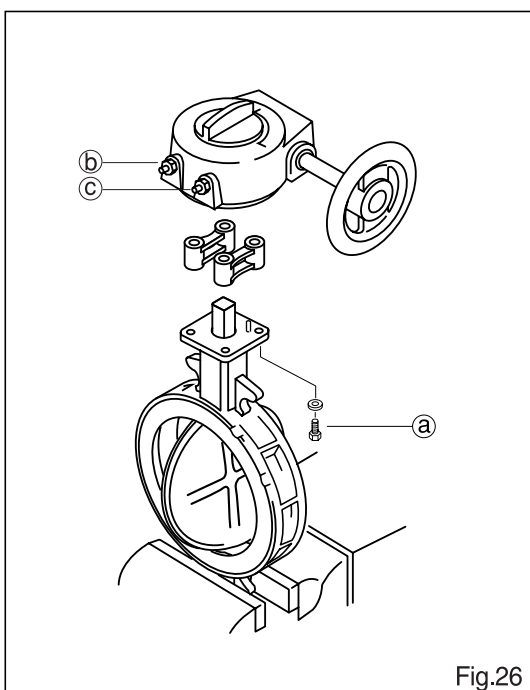

Fig.26

#### 2.Gear operation type (Fig.26)

1. **Check the disc position** : Open the valve fully.
2. **Check the gear position** : Keep the valve fully opened by turning the handwheel.
3. **Set the actuator** : Connect and fix the gear operator to the upper shaft with four bolt<sup>Ⓐ</sup>.
4. **Opening or closing adjustment**  
**[How to set Opening point]** Release lock nut<sup>Ⓒ</sup>, tighten the adjustment bolt until it slightly stops, then, quarter-turn the adjustment bolt, tighten the lock nut<sup>Ⓒ</sup>.  
**[How to set closing point]** Release lock nut<sup>Ⓒ</sup>, open the valve fully by turning the handwheel after checking the disc touches the rubber seat fully, tighten the adjustment bolt<sup>Ⓒ</sup> until it slightly stops, then, quarter-turn the adjustment bolt<sup>Ⓒ</sup> tighten the lock nut<sup>Ⓒ</sup>.
5. **Check the valve** : Make sure if the valve can operate smoothly by turning handwheel. After checking, keep the valve in almost closed position.

※ For air-cylinder or electric motor type, contact your OKM sales representative.

# Trouble Shooting

## — For Valve Body Trouble

● In case of trouble, refer to trouble shooting chart.

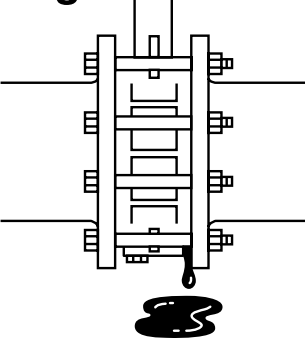
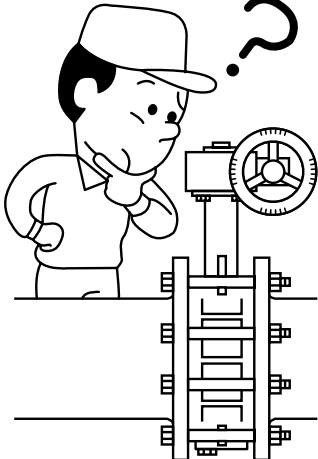
Trouble	Possible Cause	Remedy
<p><b>Leakage between valve and piping-flange</b></p> 	<p>Un-balanced fastening of piping-bolts</p> <p>Dirty or scored the surface of the flange</p> <p>The valve is not being centered on the piping flanges</p>	<p>Bolts to be once loosened and to be re-fastened well balanced</p> <p>Remove the valve and check the flange and clean it</p> <p>Loosen bolts and centering is required</p>
<p><b>Valve not to be operated or not to be operated smoothly</b></p> 	<p>Something plugs the pipings</p> <p>In case of actuated type (pneumatically or electrically), supply-source not to be as per requirement</p> <p>Damaged seat-ring (Damaged valve body, etc···)</p>	<p>Substances to be flew away keeping valve on full-open position, or to be removed with valve to be once removed from pipings</p> <p>Confirmation of supply-source with pressure guage or tester</p> <p>Remove the valve check the damaged part and replace it</p>



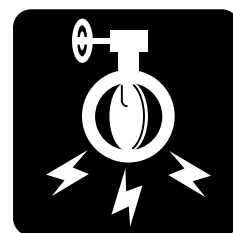

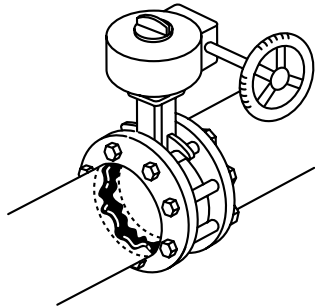
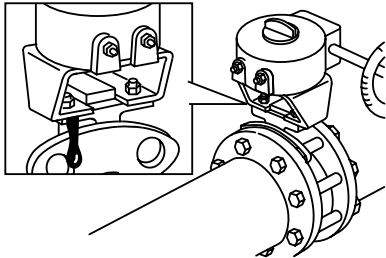
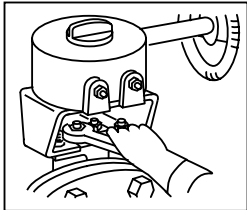
Trouble	Possible Cause	Remedy
<p><b>Leakage from seat inside pipings</b></p> 	<p>Weared seat-ring</p> <p>Operation beyond the designated fluid or specifications</p> <p>Damaged disc, foreign matter sticked</p> <p>The one side (the upstream of the direction) and the another side are the reverse - pipings</p> <p>Subject to corrosive fluid</p> <p>Subject to incorrect assembly or adjustment</p>	<p>Replace the seat-ring</p> <p>Check the specifications</p> <p>Remove the valve check the disc remove foreign matter</p> <p>Set Model 541T again in a correct direction</p> <p>Choose valve whose material is suitable for the fluid consult OKM sales representative</p> <p>Adjust the closing point</p>
<p><b>Leakage from grand</b></p> 	<p>Stress relief for Grand packing</p> <p>Length of life</p>	<p>Tighten up grand packing again</p>  <p>Exchange grand packing (P11.P12)</p>

※ Consult OKM sales representative if problem occurs.

# Trouble Shooting

## — For Actuator Trouble

● In case of trouble, refer to trouble shooting chart.

● Actuator shape changes according to its size.

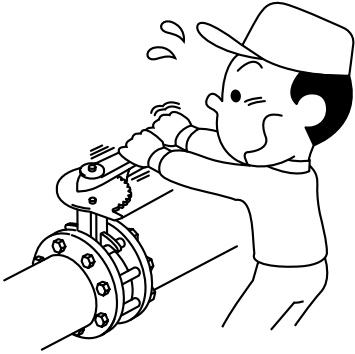
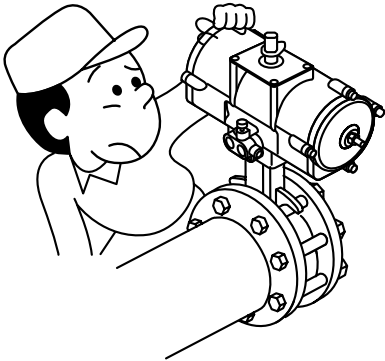
Trouble	Possible Cause	Remedy
<p><b>Lever or gear operation type</b> (No operation, non-easy operation)</p> 	<p>Mismatch the pipe size and valve size</p> <p>The disc touches the pipe</p> <p>Wrong with actuator</p> <p>Operation beyond valve specification</p>	<p>Replace the valve with correct one in size</p> <p>Put spacer or short-pipe</p> <p>Check the actuator</p> <p>Check the specification</p>
<p><b>Cylinder operation type</b> (No operation, non-easy operation)</p> 	<p>Shortage of operational air pressure</p> <p>Leakage inside the piping something plugs the piping</p> <p>A bypass valve is closed</p>	<p>Keep the specified operational air pressure 0.39 to 0.68 MPa (4 to 7 kgf/cm<sup>2</sup>)</p> <p>Clean or repair the piping</p> <p>Open a bypass valve</p>

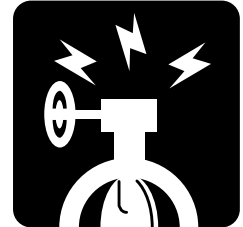

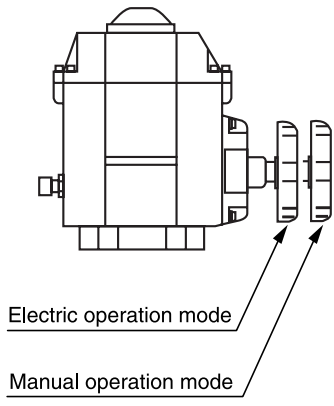
Trouble	Possible Cause	Remedy
<p><b>Electric operation type</b> (No operation)</p>  <p>Electric operation mode</p> <p>Manual operation mode</p>	<p>The handle set in manual operation mode</p> <p>The power is being off</p> <p>Wrong selection of electric supply</p> <p>Wrong wiring</p>	<p>Set the handle in electric operation mode</p> <p>Turn on power</p> <p>Check the electric supply</p> <p>Check the actuator rewire it</p>

※ Consult OKM sales representative if problem occurs.

OKM offers a excellent quality of valve for all fluidhandling industries. Please contact us or refer to OKM installation operation & maintenance instructions, asfor the details.

- For more details, contact your OKM sales representative.
- Specifications and designs are subject to change without notice.



**OKUMURA ENGINEERING corp.**  
<http://www.okm-net.co.jp/>

**HEAD Office and Factory**

446-1, Ohtani, Hino-cho, Gamo-gun, Shiga Prefecture 529-1608, Japan.  
Phone 81-748-52-2131 Fax 81-748-52-8154

**Osaka Branch**

Asahi Century Bldg. 6F, 1-7-18, Utubo-Honmachi, Nishi-ku, Osaka City, Osaka Prefecture 550-0004, Japan.  
Phone 81-6-6445-1223 Fax 81-6-6445-1333