

Compact and simple low-cost type  
 Housing of extruded aluminium sheath  
 Flexible stainless steel cable Ø 0,8 mm  
 Strong spring mechanics  
 Precision cable drum



## Inkrementaler Weggeber PLE 200

Linear Motion Transducer with 30.000 mm, 40.000 mm and 50.000 mm range, with Standard Incremental Encoder ED 58

### Used encoder

#### Used encoder

Standard Encoder ED 58

### Type explanation

#### PLE 200-500-100/ED58-6-5000-05-D-RC12

Measuring range	300 = 30.000 mm 400 = 40.000 500 = 50.000
Number of turns of the encoder shaft	Messlänge in mm / 500 mm
Encoder type	Incremental
Number of channels	3 = A + B + M 6 = AA + BB + MM
Supply voltage	05 = 5 VDC ± 5% 30 = 10..30 VDC
Output driver	D-RS422 P
Position of connection	R S
Connector	C07 = 7 pins Binder C12 = 12 pins M23 M10 = 10 pins MIL

## Technical data

### Mechanical data

Acceleration of cable	? 20 ms <sup>-2</sup>
Side movement of cable	? 3°
Weight	? 10 kg (PLE200-300-60) ? 11 kg (PLE200-400-80) ? 12 kg (PLE200-500-100)

### Environmental conditions

Vibration	100 ms <sup>-2</sup> (20 ... 2000 Hz)
Shock	200 ms <sup>-2</sup>
Operating temperature	0 ... +80°C
Storage temperature	-40 ... +80°C
Atmospheric humidity	? 95% r.h.
Protection class	IP 65 (Standard Encoder ED 58) IP 40 (Mechanic of Linear Motion Transducer)

### Electrical data

Scanning type	Optical, without contact
Transmitter, infrared	LED
Receiver	Photo-Array
Supply voltage	V <sub>cc</sub> = 5 VDC ±5% V <sub>cc</sub> = 10...30 VDC
Power consumption	200 mA max.
Output frequency	? 300 kHz (Output D) ? 160 kHz (Output P)
Signal level	High > V <sub>cc</sub> -2 V Low < 0,5 V
Load capacity of the outputs	20 mA

## Cable

Wire colour	Signal
Brown 0,5 mm <sup>2</sup>	+Vcc
Blue	+Vcc Sense <sup>1)</sup>
White 0,5 mm <sup>2</sup>	0 V GND
White	0 V Sense
Brown	Signal A+
Green	Signal A- <sup>2)</sup>
Grey	Signal B+
Pink	Signal B- <sup>2)</sup>
Red	Signal M+
Black	Signal M- <sup>2)</sup>
Shield	N.C.

1) nur bei Vcc = 5 VDC TTL

2) nur bei 6 Ausgangskanälen

## Connector 7 pins Binder

Connection	Signal
Pin 1	0 V GND
Pin 2	N.C.
Pin 3	Signal A
Pin 4	Signal B
Pin 5	+Vcc
Pin 6	Signal M
Pin 7	Shield

## Connector 12 pins M23

Connection	Signal
Pin 1	Signal B- <sup>1)</sup>
Pin 2	+Vcc Sense <sup>2)</sup>
Pin 3	Signal M+
Pin 4	Signal M- <sup>1)</sup>
Pin 5	Signal A+
Pin 6	Signal A- <sup>1)</sup>
Pin 7	N.C.
Pin 8	Signal B+
Pin 9	Shield
Pin 10	0 V GND
Pin 11	0 V Sense
Pin 12	+Vcc

1) nur bei 6 Ausgangskanälen

2) nur bei Vcc = 5 VDC TTL

## Connector 10 pins MIL

Connection	Signal
Pin A	Signal B+
Pin B	Signal A+
Pin C	Signal M+
Pin D	+Vcc
Pin E	+Vcc Sense
Pin F	0 V GND
Pin G	Shield
Pin H	Signal B- <sup>1)</sup>
Pin I	Signal A- <sup>1)</sup>
Pin J	Signal M- <sup>1)</sup>

## Output driver

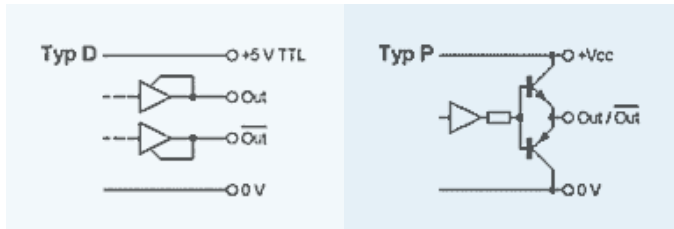

## Output channels / Output signals

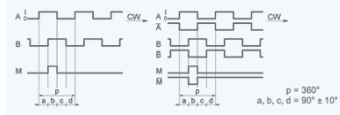

## Outline drawing

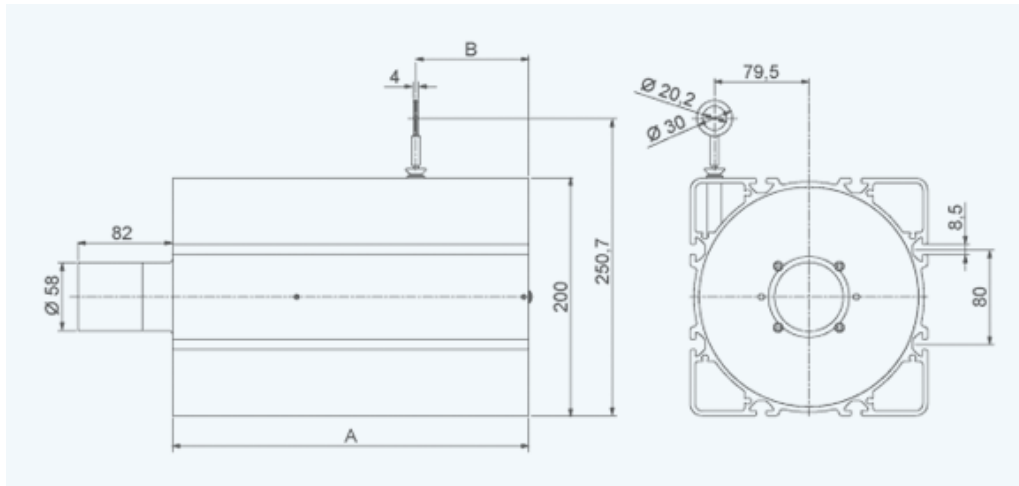

Version ZE 621-611 · Subject to change

INDUcoder® · INDUcoder Messtechnik GmbH, Kaiserstraße 316, 47178 Duisburg, Deutschland  
Tel: (0203) 57047-0, Fax: (0203) 57047-20, E-Mail: [info@inducoder.de](mailto:info@inducoder.de), Internet:  
[www.inducoder.de](http://www.inducoder.de)