

Compact and simple low-cost type
 Housing of extruded aluminium sheath
 Flexible stainless steel cable Ø 1 or 1,2 mm
 Strong spring mechanics
 Precision cable drum



Inkrementaler Weggeber PLE 85 / PLE 115

Linear Motion Transducer up to 15.000 mm range, with Standard Incremental Encoder ED 58

Used encoder

Used encoder

Standard Encoder ED 58

Type explanation

PLE 85-25-12/ED58-6-8192-05-D-RC12

Measuring range	25 = 2.500 mm 50 = 5.000 mm 75 = 7.500 mm 100 = 10.000 mm 150 = 15.000 mm
Encoder type	Incremental
Number of channels	3 = A + B + M 6 = AA + BB + MM
Resolutions	xxxx = Impulse pro Umdrehung
Supply voltage	05 = 5 VDC ± 5% 30 = 10..30 VDC
Output driver	D-RS422 P
Position of connection	R S
Connector	C07 = 7 pins Binder C12 = 12 pins M23 M10 = 10 pins MIL

Technical data

Mechanical data

Acceleration of cable	? 30 ms ⁻² (PLE115-100, PLE115-150) ? 50 ms ⁻² (PLE85-25, PLE115-50) ? 60 ms ⁻² (PLE115-75)
Side movement of cable	? 3°
Weight	? 1,3 kg (PLE 85) ? 1,7 ... 3,7 kg (PLE 115)

Environmental conditions

Vibration	200 ms ⁻² (20 ... 2000 Hz)
Shock	500 ms ⁻²
Operating temperature	0 ... +80°C
Storage temperature	-40 ... +80°C
Atmospheric humidity	? 95% r.h.
Protection class	IP 65 (Standard Encoder ED 58) IP 40 (Mechanic of Linear Motion Transducer)

Electrical data

Scanning type	Optical, without contact
Transmitter, infrared	LED
Receiver	Photo-Array
Supply voltage	V _{cc} = 5 VDC ±5% V _{cc} = 10...30 VDC
Power consumption	200 mA max.
Output frequency	? 300 kHz (Output D) ? 160 kHz (Output P)
Signal level	High > V _{cc} -2 V Low < 0,5 V
Load capacity of the outputs	20 mA

Cable

Wire colour	Signal
Brown 0,5 mm ²	+Vcc
Blue	+Vcc Sense ¹⁾
White 0,5 mm ²	0 V GND
White	0 V Sense
Brown	Signal A+
Green	Signal A- ²⁾
Grey	Signal B+
Pink	Signal B- ²⁾
Red	Signal M+
Black	Signal M- ²⁾
Shield	N.C.

1) nur bei Vcc = 5 VDC TTL

2) nur bei 6 Ausgangskanälen

Connector 7 pins Binder

Connection	Signal
Pin 1	0 V GND
Pin 2	N.C.
Pin 3	Signal A
Pin 4	Signal B
Pin 5	+Vcc
Pin 6	Signal M
Pin 7	Shield

Connector 12 pins M23

Connection	Signal
Pin 1	Signal B- ¹⁾
Pin 2	+Vcc Sense ²⁾
Pin 3	Signal M+
Pin 4	Signal M- ¹⁾
Pin 5	Signal A+
Pin 6	Signal A- ¹⁾
Pin 7	N.C.
Pin 8	Signal B+
Pin 9	Shield
Pin 10	0 V GND
Pin 11	0 V Sense
Pin 12	+Vcc

1) nur bei 6 Ausgangskanälen

2) nur bei Vcc = 5 VDC TTL

Connector 10 pins MIL

Connection	Signal
Pin A	Signal B+
Pin B	Signal A+
Pin C	Signal M+
Pin D	+Vcc
Pin E	+Vcc Sense
Pin F	0 V GND
Pin G	Shield
Pin H	Signal B- ¹⁾
Pin I	Signal A- ¹⁾
Pin J	Signal M- ¹⁾

1) nur bei 6 Ausgangskanälen

Output driver

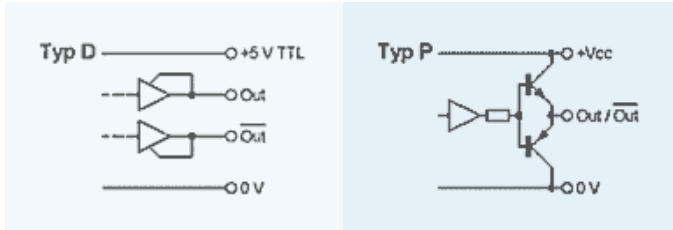

Outline drawing

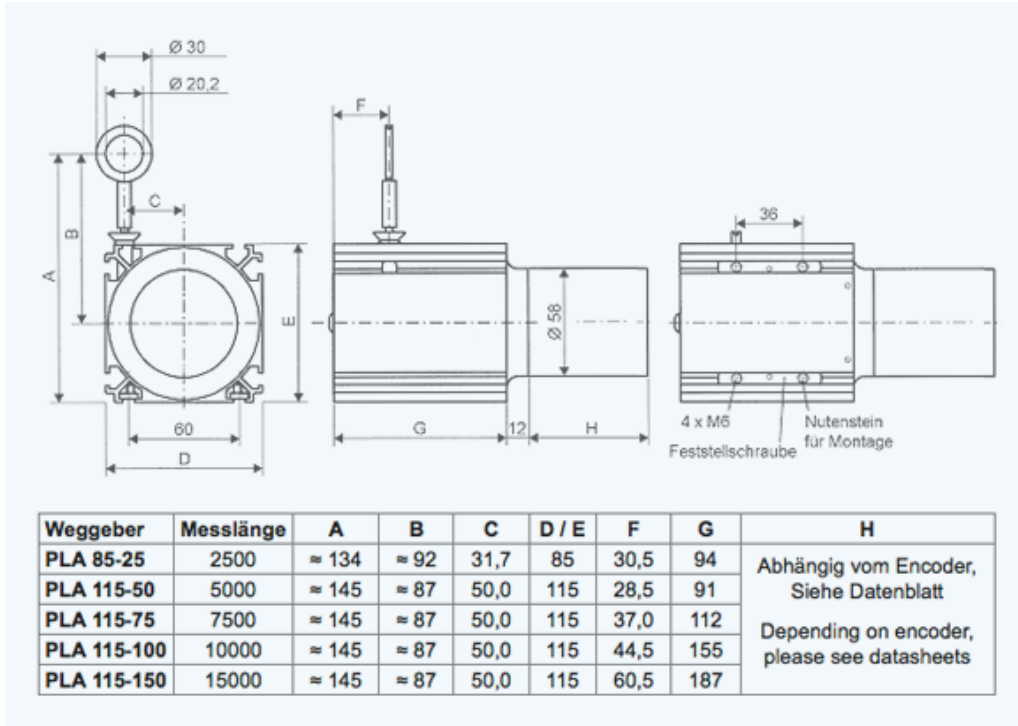

Version ZE 612-411 · Subject to change

INDUcoder® · INDUcoder Messtechnik GmbH, Kaiserstraße 316, 47178 Duisburg, Deutschland
 Tel: (0203) 57047-0, Fax: (0203) 57047-20, E-Mail: info@inducoder.de, Internet:
www.inducoder.de