

## LP30 - NON-CONTACT LINEAR POSITION

*Alternative to wire-reel method for linear extension measurement*

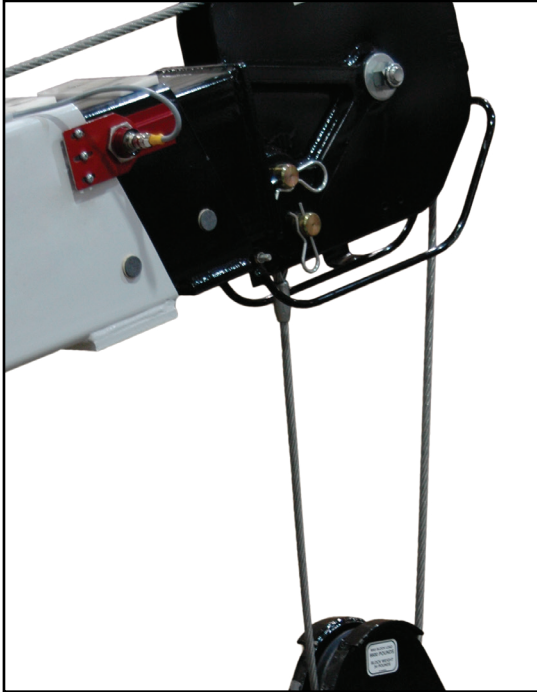

**LINEAR POSITION SENSORS (IP69K)**

**LP30 Linear Position** *incremental or absolute non-contact*

- J1939 CAN Bus incremental or absolute linear
  - Totally sealed IP69K (*connector dependent*)
  - Non-contact with wide sensing range
  - Compact housings for simple integration
  - MILSPEC 202 ratings for shock and vibration
  - 1/4" to 1" resolution standards
    - Custom resolution and magnet assemblies available
  - Intelligent and rugged replacement to wire-reel cable / string-pot boom measure systems



**STANDARD OPERATING CHARACTERISTICS**

ELECTRICAL	Outputs	<b>A - 1939</b> J1939, Addressable, Incremental position <i>(attached message sheets S3 ; I2 / 5 - 7)</i>
	Input Power	6 to 30 VDC (30 mA)
	Electrical Protection	Over-voltage, reserve-voltage, output short-circuit protected
	LED Indicators	Power, J1939 communication status
	Connections	M12, M12 Pigtail, Flying Lead Cable, Shielded Flying Lead, or Deutsch - 4 or 6 pin
	Resolution	1/2" or 1/4" ( <i>custom resolution packages available, contact Joral</i> )
MECHANICAL	Housing Diameter	30mm
	Housing Material	Aluminum or Stainless Steel ( <i>corrosion resistant</i> )
	Housing Height	1.2" (30.5mm) body; 1.86" (47.2mm) w/ M12 connector
	Mounting	30mm thread ( <i>standard proximity switch thread style</i> )
	Weight	1.0 oz w/o mounting nuts; 2.2 oz w/ recommended mounting nuts
	Magnet strip / sensor gap*	Standard 0.5"
ENVIRONMENTAL	Operating Temperature	-40° to +80° C
	Storage Temperature	-40° to +90° C
	Humidity	100%
	Shock	400g/6ms (MIL STD 202)
	Vibration	5 to 3000 Hz, 20g (MIL STD 202)
	Protection Class	IP69K ( <i>connection dependent</i> )

\* Non-contact tolerances rated using MAG-STRP magnet accessory.

**LP30 GENERAL ORDERING GUIDE**

Code 1: Housing Style	Code 2: MagElec (Sensor Output)	Code 3: Connection	Code 4: Special Codes
<b>LP30</b> LP30 red aluminum, for 1/2" extended thread add 61 to end of P/N. Increases total shell body by 1/2"  <b>LP30 Modifier Stainless Steel:</b> <b>LP30 - [Code 2] - [Code 3] - 54</b> Code 54 for stainless steel corrosion resistant housing 30mm non-contact	<b>A - 1939</b> J1939, Addressable, Incremental signal  * More outputs and connection options available, contact Joral if desired configuration is not listed	<b>M12</b> M12 male	<b>51</b> Red Aluminum
		<b>M12P</b> M12 male on 18' pigtail	<b>53</b> Black Aluminum
		<b>CXX</b> Flying lead cable (enter XX as inches)	<b>54</b> Stainless Steel
			<b>61</b> Extended Thread
		<b>SCXX</b> Shielded cable (enter XX as inches)	<b>DE4</b> DT04 - 4 pin male Deutsch
			<b>DE6</b> DT04 - 6 pin male Deutsch

General dimensions found on next page (S3 ; I2 / 3 - 4)  
J1939 setting/status message found on pages three and four (S3 ; I2 / 5 - 7)



**LP30 DIMENSIONS & GENERAL PIN OUTS** DIMENSIONS 1 OF 2

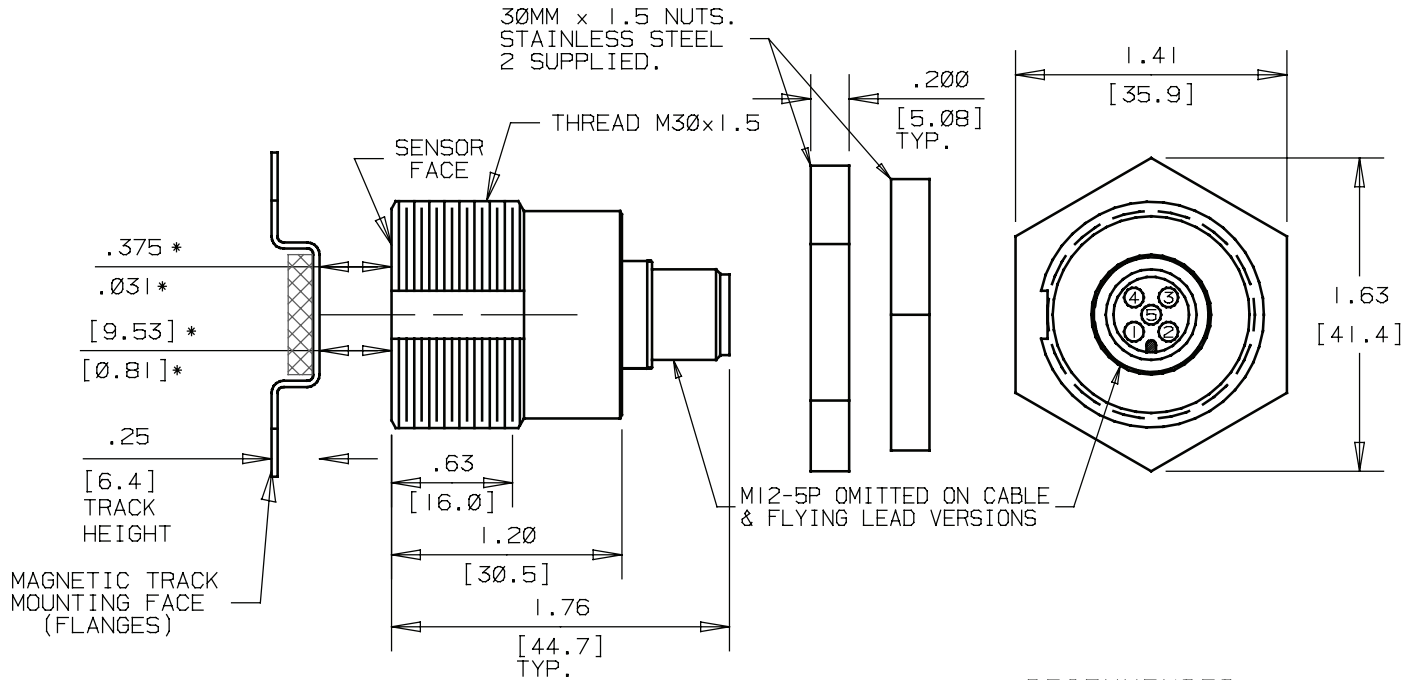

**MAGNET TRACK/SENSOR INSTALL NOTE:**  
SENSING WINDOW MAY BE SMALLER  
DEPENDANT ON SENSOR MOUNT MATERIALS

MAGNETIC TRACK IS MOUNTED BY ITS FLANGES  
USING VHB DOUBLE FACED ADHESIVE TAPE OR  
POP RIVETS OR SCREWS (NOT SUPPLIED)

WHEN EXTENDING MAGNETIC TRACS THE TRACK  
END FEATURES MUST BE NESTED

RECOMMENDED  
MOUNTING HOLE

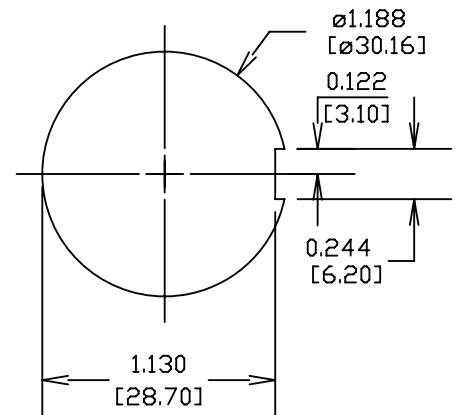

**PINOUTS ON DIMENSIONS PAGE 2 OF 2**

*Dimensions informative only  
For most recent dimensions please consult factory*



**LP30 DIMENSIONS & GENERAL PIN OUTS** DIMENSIONS 2 OF 2

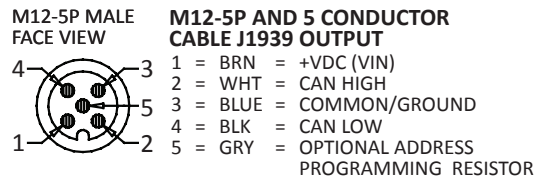
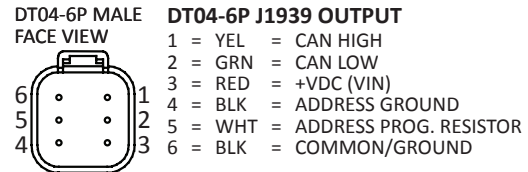
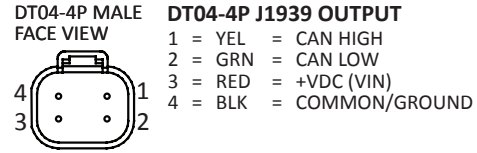
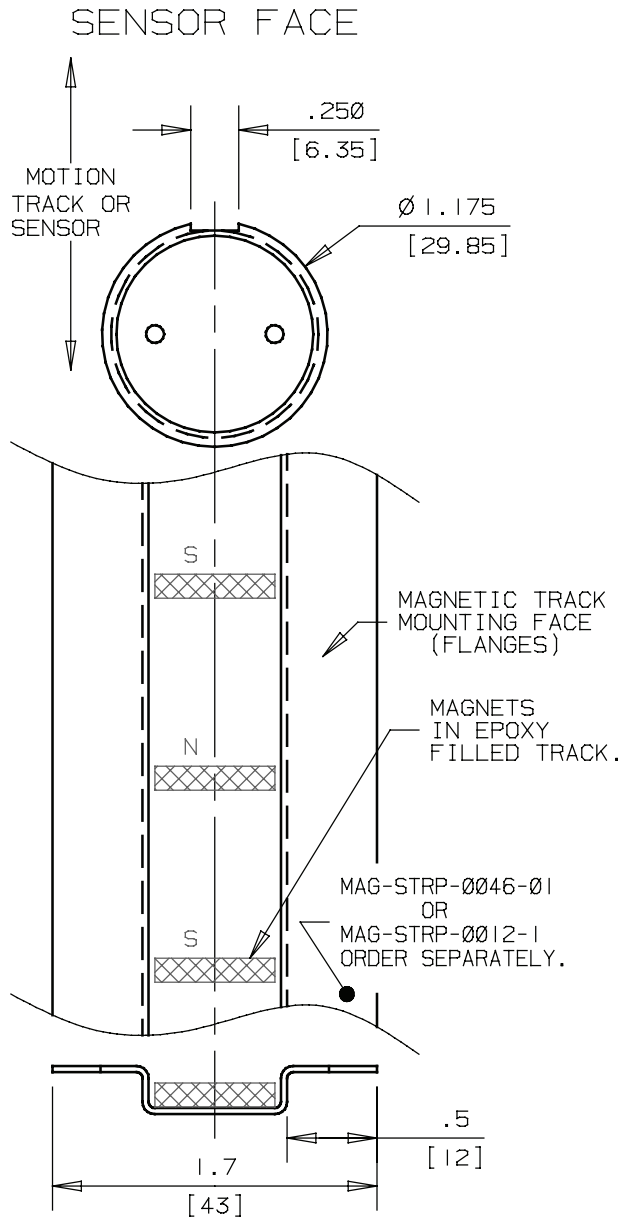

**MAGNET TRACK/SENSOR INSTALL NOTE:**  
SENSING WINDOW MAY BE SMALLER  
DEPENDANT ON SENSOR MOUNT MATERIALS

MAGNETIC TRACK IS MOUNTED BY ITS FLANGES  
USING VHB DOUBLE FACED ADHESIVE TAPE OR  
POP RIVETS OR SCREWS (NOT SUPPLIED)

WHEN EXTENDING MAGNETIC TRACS THE TRACK  
END FEATURES MUST BE NESTED

Dimensions informative only  
For most recent dimensions please consult factory



**J1939 LP30 LINEAR SENSOR - STATUS Message 65450**

**MESSAGE PARAMETERS**

This message is transmitted by sensor at REP Rate

<b>PGN: 65450 (FFAA hex)</b>	
Transmission Repetition Rate	50ms
Data Length	8 bytes
Data Page	0
PDU Format	255 (FF hex)
PDU Specific	170 (AA hex)
Priority	4
Source Address	214 (D6 hex)
Communication Bit Rate	250 K bits/sec

**PART NUMBERS**

5 pin M12	LP30-A-1939-M12
4 pin DT04	LP30-A-1939-DE4
6 pin DT04	LP30-A-1939-DE6
Flying Lead	LP30-A-1939-SCXX
<i>For flying lead replace XX with desired length in inches</i>	
<i>For high corrosive applications use stainless steel housing. Add modifier 53 to end of Joral P/N for stainless steel housing.</i>	

**CONNECTIONS / WIRING**

Signal	M12 5 pin	DE4	DE6
V+	1	3 RED	3 RED
Common	2	4 BLACK	4 BLACK
CANH	3	1 YELLOW	1 YELLOW
CANL	4	2 GREEN	2 GREEN
SA Select	5		5 WHITE
Common			6 BLACK

**SOURCE ADDRESS SELECTION**

Value (ohms)	Address	PGN
No Resistor	214	65450
590 (id-tag 1)	215	65450
976 (id-tag 2)	216	65450
1500 (id-tag 3)	217	65450
2260 (id-tag 4)	218	65450
3400 (id-tag 5)	219	65450
5360 (id-tag 6)	220	65450
9530 (id-tag 7)	221	65450

**8 BYTE / 64 BIT DATA FIELD BIT POSITIONS**

BYTE	BIT	BIT FUNCTION	FIELD DESCRIPTION
BYTE 1	1	SPEED Setting LSB	<b>SPEED Setting (2 bits)</b> 00 = Slow; 01 = Medium; 10 = Fast
	2	SPEED Setting MSB	
	3	DIRECTION Setting LSB	<b>DIRECTION Setting (2 bits)</b> 00 = FWD direction counts up; 01 = REV direction counts up
	4	DIRECTION Setting MSB	
	5	SAVE CNT Setting LSB	<b>SAVE COUNT Setting (2 bits)</b> At power : 00 = Counter resets to 0; 01 = Counter will start from last saved count
	6	SAVE CNT Setting MSB	
	7	SAVE ON SPEED LSB	<b>SAVE ON ZERO SPEED Setting (2 bits)</b> 00 = Do not save count on speed becoming 0; 01 = Save count when speed becomes 0
	8	SAVE ON SPEED MSB	
BYTE 2	9	unused	<b>NOTE: Set reserved and unused bits to all 0's or all 1's</b>
	10	unused	
	11	unused	
	12	unused	
	13	REV direction Flag LSB	
14	REV direction Flag MSB		
BYTE 3	15	FWD direction Flag LSB	<b>FWD DIRECTION (2 bits)</b> 01 means counting up
	16	FWD direction Flag MSB	
	17	SPEED bit0 LSB	<b>SPEED (10 bits)</b> Speed in inches per second, 0.5" per second per bit, 0 to 1000 (0.25" per bit per second if 1/4" resolution option is installed)  SPEED is calculated by running average on 100msec intervals 00 (slow) averages 3 seconds of counts per calculation 01 (medium) averages 1 second of counts per calculation 02 (fast) averages 100 msecs of counts per calculation
18	SPEED bit1		
19	SPEED bit2		
20	SPEED bit3		
21	SPEED bit4		
22	SPEED bit5		
23	SPEED bit6		
24	SPEED bit7		
25	SPEED bit8		
26	SPEED bit9 MSB		
BYTE 4	27	unused	<b>POSITIVE COUNT Flag (2 bits)</b> 01 means count is positive
	28	unused	
	29	POS Count Flag LSB	<b>NEGATIVE COUNT Flag (2 bits)</b> 01 means count is negative
	30	POS Count Flag MSB	
	31	NEG Count LSB	<b>COUNT (32 bits)</b> Incremental Count, 0.5" per count (0.25" per bit per second if 1/4" resolution option is installed)  Count maximum value is 2, 147, 483, 647
	32	NEG Count MSB	
BYTE 5	33	Count bit0 LSB	
	34	Count bit1	
	35	Count bit2	
	36	Count bit3	
	37	Count bit4	
	38	Count bit5	
	39	Count bit6	
	40	Count bit7	
BYTE 6	41	Count bit8	
	42	Count bit9	
	43	Count bit10	
	44	Count bit11	
	45	Count bit12	
	46	Count bit13	
	47	Count bit14	
	48	Count bit15	
BYTE 7	49	Count bit16	
	50	Count bit17	
	51	Count bit18	
	52	Count bit19	
	53	Count bit20	
	54	Count bit21	
	55	Count bit22	
	56	Count bit23	
BYTE 8	57	Count bit24	
	58	Count bit25	
	59	Count bit26	
	60	Count bit27	
	61	Count bit28	
	62	Count bit29	
	63	Count bit30	
	64	Count bit31 MSB	



**J1939 LP30 LINEAR SENSOR - SETTING Message 65449**

**MESSAGE PARAMETERS**

This message is transmitted by the controller

<b>PGN: 65449 (FFA9 hex)</b>	
Transmission Repetition Rate	50 ms
Data Length	8 bytes
Data Page	0
PDU Format	255 (FF hex)
PDU Specific	169 (A9 hex)
Priority	4
Source Address	214 (D6 hex)
Communication Bit Rate	250 K bits/sec

**CONNECTIONS / WIRING**

Signal	M12 5 pin	DE4	DE6
V+	1	3 RED	3 RED
Common	2	4 BLACK	4 BLACK
CANH	3	1 YELLOW	1 YELLOW
CANL	4	2 GREEN	2 GREEN
SA Select	5		5 WHITE
Common			6 BLACK

**SOURCE ADDRESS SELECTION**

Value (ohms)	Address	PGN
No Resistor	214	65449
590 (id-tag 1)	215	65449
976 (id-tag 2)	216	65449
1500 (id-tag 3)	217	65449
2260 (id-tag 4)	218	65449
3400 (id-tag 5)	219	65449
5360 (id-tag 6)	220	65449
9530 (id-tag 7)	221	65449

**8 BYTE / 64 BIT DATA FIELD BIT POSITIONS**

BYTE	BIT	BIT FUNCTION	FIELD DESCRIPTION
BYTE 1	1	SPEED Setting LSB	<b>SPEED Settings (2 bits)</b> 00 = Slow; 01 = Medium; 10 = Fast
	2	SPEED Setting MSB	
	3	DIRECTION Setting LSB	<b>DIRECTION Setting (2 bits)</b> 00 = CW direction counts up; 01 = CCW direction counts up
	4	DIRECTION Setting MSB	
	5	SAVE CNT Setting LSB	<b>SAVE COUNT Setting (2 bits)</b> At power : 00 = Counter resets to 0; 01 = Counter will start from last saved count
	6	SAVE CNT Setting MSB	
	7	SAVE ON SPEED LSB	<b>SAVE ON ZERO SPEED Setting (2 bits)</b> 00 = Do not save count on speed becoming 0; 01 = Save count when speed becomes 0
	8	SAVE ON SPEED MSB	
BYTE 2	9	unused	<b>NOTE: Set reserved and unused bits to all 0's or all 1's</b>
	10	unused	
	11	unused	
	12	unused	
	13	unused	
	14	unused	
	15	unused	
	16	unused	
BYTE 3	17	unused	
	18	unused	
	19	unused	
	20	unused	
	21	unused	
	22	unused	
	23	unused	
	24	unused	
BYTE 4	25	unused	
	26	unused	
	27	unused	
	28	unused	
	29	unused	
	30	unused	
	31	unused	
	32	unused	
BYTE 5	33	unused	
	34	unused	
	35	unused	
	36	unused	
	37	unused	
	38	unused	
	39	unused	
	40	unused	
BYTE 6	41	unused	
	42	unused	
	43	unused	
	44	unused	
	45	unused	
	46	unused	
	47	unused	
	48	unused	
BYTE 7	49	unused	
	50	unused	
	51	unused	
	52	unused	
	53	unused	
	54	unused	
	55	unused	
	56	unused	
BYTE 8	57	unused	
	58	unused	
	59	unused	
	60	unused	
	61	unused	
	62	unused	
	63	unused	
	64	unused	



**J1939 LP30 LINEAR SENSOR - SETTING Message 65451**

**MESSAGE PARAMETERS**

This message is transmitted by the controller

<b>PGN: 65451 (FBAB hex)</b>	
Transmission Repetition Rate	n/a
Data Length	n/a
Data Page	0
PDU Format	255 (FF hex)
PDU Specific	171 (AB hex)
Priority	X
Source Address	39 (27 hex)
Communication Bit Rate	250 K bits/sec

**CONNECTIONS / WIRING**

Signal	M12 5 pin	DE4	DE6
V+	1	3 RED	3 RED
Common	2	4 BLACK	4 BLACK
CANH	3	1 YELLOW	1 YELLOW
CANL	4	2 GREEN	2 GREEN
SA Select	5		5 WHITE
Common			6 BLACK

**SOURCE ADDRESS SELECTION**

Value (ohms)	Address	PGN
No Resistor	214	65451
590 (id-tag 1)	215	65452
976 (id-tag 2)	216	65453
1500 (id-tag 3)	217	65454
2260 (id-tag 4)	218	65455
3400 (id-tag 5)	219	65456
5360 (id-tag 6)	220	65457
9530 (id-tag 7)	221	65458

**8 BYTE / 64 BIT DATA FIELD BIT POSITIONS**

BYTE	BIT	BIT FUNCTION	FIELD DESCRIPTION
BYTE 1	1	RESET COUNT LSB	<b>RESET COUNTER (2 bits)</b> 01 = Reset counter to zero
	2	RESET COUNT MSB	
	3	reserved	
	4	reserved	
	5	RPM RATE LSB	<b>RPM RATE (2 bits)</b> 00 = Slow; 01 = Medium; 10 = Fast
	6	RPM RATE MSB	
	7	DIRECTION Setting LSB	<b>DIRECTION (2 bits)</b> 00 = FWD direction counts up; 01 = REV direction counts up
	8	DIRECTION Setting MSB	
BYTE 2	9	SAVE CNT Setting LSB	<b>SAVE COUNT Setting (2 bits)</b> At power : 00 = Counter resets to 0; 01 = Counter will start from last saved count
	10	SAVE CNT Setting MSB	
	11	CLEAR CNT Setting LSB	<b>CLEAR COUNT (2 bits)</b> 01 = Clear saved Count; If clear is the last saved sensor will start from 0
	12	CLEAR CNT Setting MSB	
	13	SAVE ON SPEED LSB	<b>SAVE ON ZERO SPEED Setting (2 bits)</b> 00 = Do not save count on speed becoming 0; 01 = Save count when speed becomes 0
	14	SAVE ON SPEED MSB	
	15	ENABLE STAT MSG LSB	<b>ENABLE SETTING STATUS MESSAGE (2 bits)</b> At power : 00 = Do not enable setting status message; 01 = Enable setting status msg 65449 for transmission
	16	ENABLE STAT MSG MSB	
BYTE 3	17	unused	<b>NOTE: Set reserved and unused bits to all 0's or all 1's</b>
	18	unused	
	19	unused	
	20	unused	
	21	unused	
	22	unused	
	23	unused	
	24	unused	
BYTE 4	25	unused	
	26	unused	
	27	unused	
	28	unused	
	29	unused	
	30	unused	
	31	unused	
	32	unused	
BYTE 5	33	unused	
	34	unused	
	35	unused	
	36	unused	
	37	unused	
	38	unused	
	39	unused	
	40	unused	
BYTE 6	41	unused	
	42	unused	
	43	unused	
	44	unused	
	45	unused	
	46	unused	
	47	unused	
	48	unused	
BYTE 7	49	unused	
	50	unused	
	51	unused	
	52	unused	
	53	unused	
	54	unused	
	55	unused	
	56	unused	
BYTE 8	57	unused	
	58	unused	
	59	unused	
	60	unused	
	61	unused	
	62	unused	
	63	unused	
	64	unused	

