

Swash-plate Axial Piston Pump **K3VL Series**

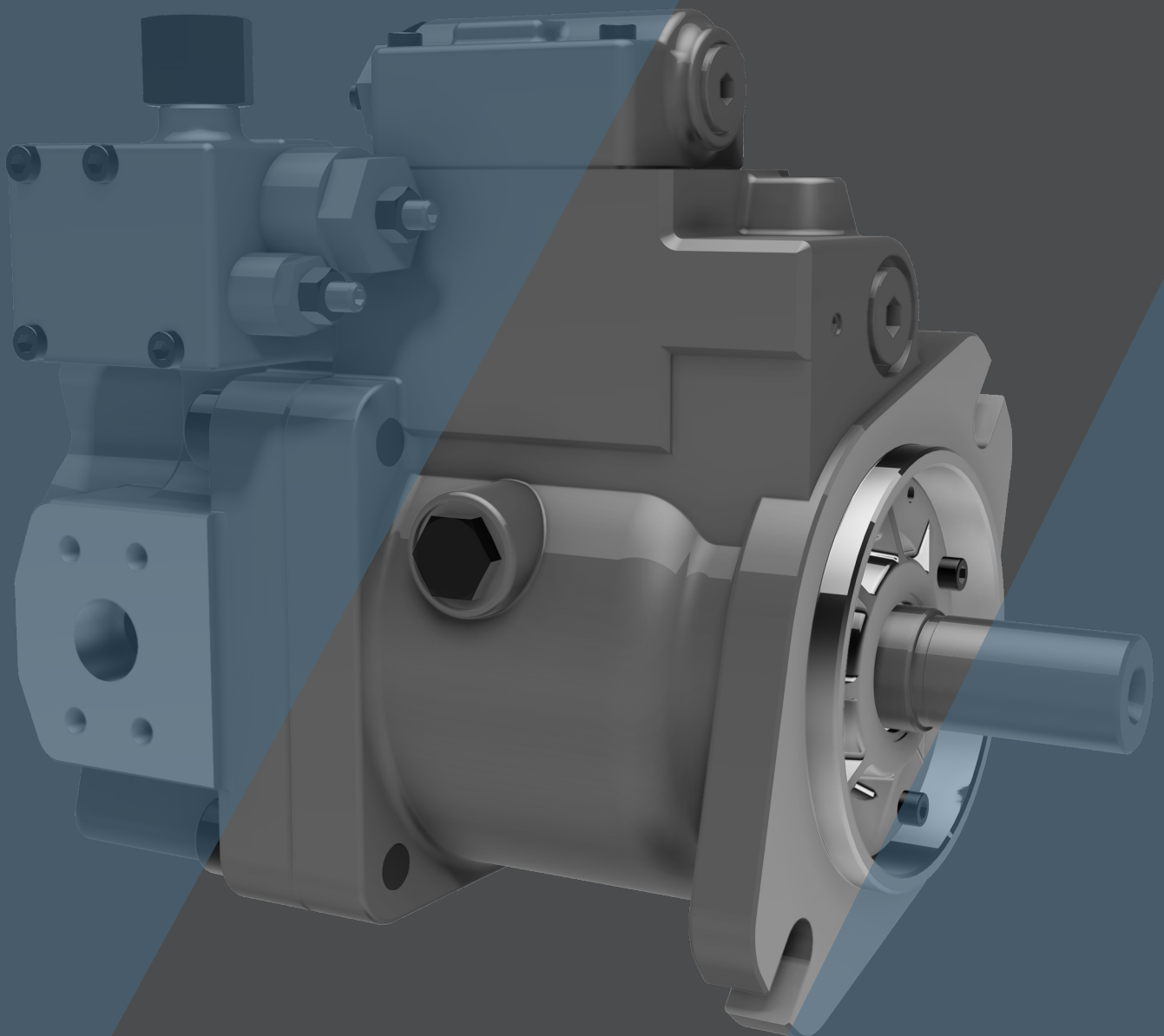

CONTENTS

Applications / Product Usage	3
Safety Precautions	4
Handling Precautions	5 - 8
Conversion Factors, Formula and Definition	9
Specifications and Features	
1. Ordering Code	
1-1. Pump Options	12 - 14
2. Technical Information	
2-1. Specifications	15 - 17
2-2. Technical Data	18
2-3. Performance Data	19 - 25
2-4. Radial Loading Capacity	26
2-5. Functional Description of Regulator	27 - 32
2-6. Torque Limiter Settings	33 - 34
2-7. Installation	35 - 38
3. Dimensions	
3-1. K3VL28 Installation	39 - 41
3-2. K3VL45/60 Installation	42 - 46
3-3. K3VL80 Installation	47 - 51
3-4. K3VL112/140 Installation	52 - 59
3-5. K3VL200 Installation	60 - 65
3-6. K3VL200H Installation	66 - 69
3-7. Electric Displacement Control	70
3-8. Unloading & Proportional Pressure Control Installation	71
3-9. Power Shift Control Installation	72
3-10. Calibration of Regulators	73

Applications/Product Usage





The following must be taken into consideration before use.

1. The operating condition of the products shown in this catalog varies depending upon each application. Therefore, the product suitability must be judged by the designer of the hydraulic system and/or the person who finalizes the technical specifications of the machine after analysis and testing. The product specification shall be determined based on the latest catalog and technical documents. The system must be designed taking into account the possibility of machine failure to ensure that all safety, warning, and application requirements are met.
2. For the proper use of the products, descriptions given in the SAFETY PRECAUTIONS must be observed.
3. The technical information in this catalog represents typical characteristics and performance of the products as of the published date.
4. If the intended use of the products is included in the following, please consult with Kawasaki in advance.
 - (1) Use the product in the operating conditions or environments other than those described in the technical documents.
 - (2) Use the product in the nuclear sector, aviation sector, medical sector, and/or food sector.
 - (3) Use the product in applications which may cause substantial harm to others and their property, and especially in applications where ensuring safety is a requirement.
5. The information described in this catalog is subject to change without notice. For the latest information, please contact Kawasaki.





Safety Precautions

Before using the product, you **MUST** read this catalog and **MUST** fully understand how to use the product. To use the product safely, you **MUST** carefully read all Warnings and Cautions in this catalog.













1. Cautions related to operation

-  - Use the personal protective equipment to prevent injury when the product is in operation.
-  - Some components are heavy. Handle the product carefully not to hurt your hands and lower back.
-  - Do not step on, hit or drop , or apply strong force to the product, as these actions may cause operation failure, product damage, or oil leakage.
-  - Wipe off any oil on the product or the floor completely, as oil can create slippery conditions that may cause drop of the product and personal injury.

2. Warnings and cautions related to installation and removal of the product

-  - Installation, removal, piping, and wiring must be done by a qualified technician.
-  - Make sure that the hydraulic power unit is turned off and that the electric motor or engine has completely stopped before starting installation or removal. You must also check that the system pressure has dropped to zero.
-  - Make sure that the power source is turned off before installing electric components to reduce the risk of electric shock.
-  - Clean the threads and the mounting surface to prevent damage or oil leakage. Inadequate cleaning may cause insufficient torque and broken seals.
-  - Use the designated bolts and fasten them with prescribed torque when installing the product. Use of undesignated bolts, and excessive or insufficient tightening torque may induce operation failure, damage, or oil leakage.

3. Warnings and cautions for operation

-  - Always equip the product with explosion or ignition protection if it is used in potentially explosive or combustible atmospheres.
 -  - Shield rotary parts, such as the motor and pump shaft, to avoid injury.
 -  - Stop operation immediately, and take proper measures when the abnormality such as unusual noise, oil leakage, and smoke is found. Continuing operation under such condition may bring about damage, a fire hazard, or injury.
 -  - Make sure that all pipes, hoses, and connecting points with pipes or hoses, are correctly connected and tightened before starting operation.
 -  - Use the product under the operating conditions and limitations described in the catalog, drawings, and specification sheets.
 -  - Do not touch the product in operation. to reduce the risk of skin burn.
 -  - Use the proper hydraulic oil and maintain the filtration at the recommended level to prevent premature wear and damage.
- ## 4. Cautions related to maintenance
-  - Never modify the product without approval from Kawasaki.
 -  - Disassembly of the product may void the warranty.
 -  - Keep the product clean and dry when storing or transporting.
 -  - The seals may need to be replaced if the product has been stored for an extended period of time.
 -  - Making adjustments of this product will result in the warranty being null and void.

Handling Precautions

1. Operating Fluid and Temperature Range

1) Operating Fluid

Values shown in this catalog are based upon using mineral oil based anti-wear hydraulic fluid. To ensure optimal performance use of mineral oil based anti-wear hydraulic fluid is recommended.

2) Viscosity and temperature range

To minimize both oil and seal deterioration, a maximum operating temperature of 60°C should be considered. Please note that the regulator may become slow to respond when operating at low temperatures (below 20°C) in extreme cold environments. At such low temperature it is strongly suggested that a warm up cycle is introduced until an operating temperature of 20°C is achieved.

	Normal operating range	Allowable range
Viscosity [mm ² /s(cSt)]	10 to 200	10 to 1,000
Fluid temperature [°C (°F)]	-20 to +95 (-4 to +203)	

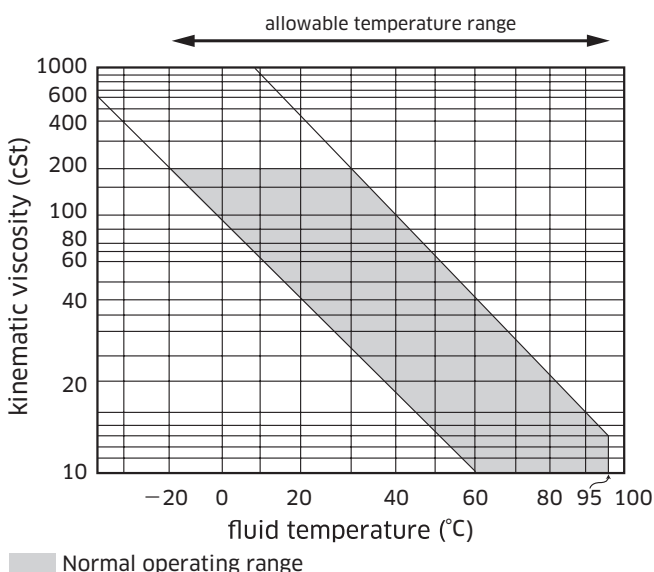

2. Filtration and Contamination Control

1) Filtration of working oil

The most important means to prevent premature damage to the pump and associated equipment and to extend its working life, is to ensure that hydraulic fluid contamination control of the system is working effectively.

This begins by ensuring that at the time of installation that all piping, tanks etc. are rigorously cleaned in a sanitary way. Flushing should be provided using an off line filtration system and after flushing the filter elements should be replaced.

A full flow return line filter of 10 micron nominal should be utilised to prevent contaminant ingress from the external environment, a 5 to 10 micron filter with the tank's breather is also recommended.

2) Suggested acceptable contamination level

The relationship between contamination level and pump life is very difficult to predict as it depends on the type and nature of the contaminant present in the system. Sand or Silica in particular, due to its abrasive nature, does significantly reduce the expected life of a pump. Based on the precondition that there is no significant presence of Silica type substances then a minimum Cleanliness level of -/18/15 ISO 4406 or SAE AS 4059E Table 1 Class 9 (NAS 1638 Class 9).

3. Drive Shaft Coupling

Alignment between the prime mover and the pump shaft should be within 0.05 mm TIR*. In case the pump is directly coupled to the engine flywheel, use a flexible coupling.

*TIR = Total Indicator Reading

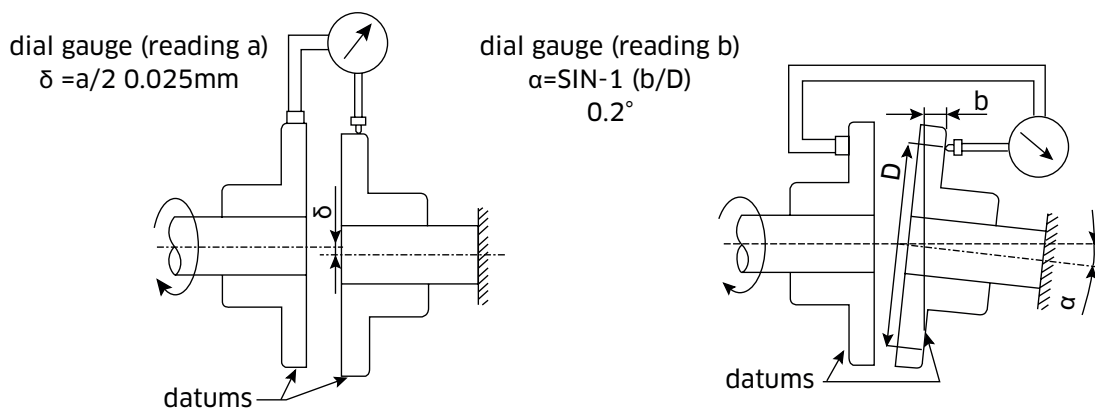

4. Oil Filling and Air Bleeding

1) Pump case filling

Be sure to fill the pump casing with oil through the drain port, filling only the suction line with oil is totally in-sufficient. The pump contains bearings and high-speed sliding parts including pistons with shoes and a spherical bush that need to be continuously lubricated. Part seizure or total premature failure will occur very quickly if this procedure is not rigidly followed.

2) Air bleeding

Run the pump unloaded for a period to ensure that all residual air within the system is released.

3) Long term out of usage

It is undesirable to leave the pump out of use for a long period e.g. a year or more. In such a situation it is recommended that the pump is run for a short period on a more frequent basis even if it is just unloaded. With regard to a pump held in storage then rotating the shaft on a frequent basis is sufficient. If the pump is left out for more than the suggested time it will require a service inspection.

5. Drain Piping

1) Installation of drain line

It is the preferred option to mount the pump with the case drain piping initially rising above the pump before continuing to the tank. Do not connect the drain line to the inlet line.

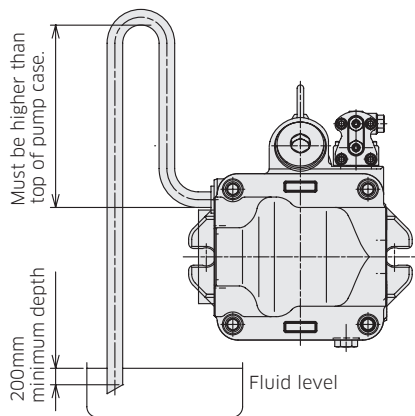

Cautions

- A)** Inlet and drain pipes must be immersed by 200 mm minimum from the lowest level under operating conditions.
- B)** Height from the oil level to the centre of the shaft must be within 1 meter maximum.
- C)** The oil in the pump case must be refilled when the pump has not been operated for one month or longer.

The uppermost drain port should be used and the drain piping must be larger in size than the drain port to minimise pressure in the pump case. The pump case pressure must not exceed 1 bar as shown in the illustration below. (Peak pressure must never exceed 4 bar.)

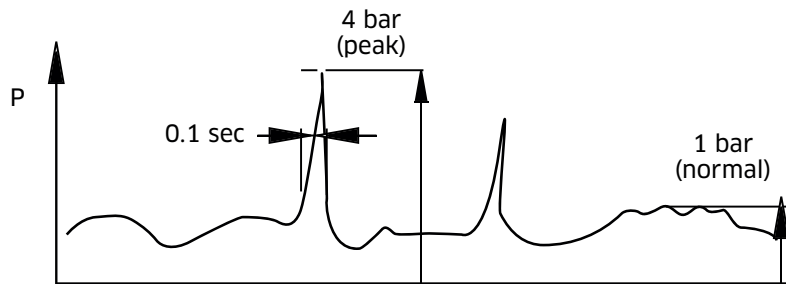

2) Size of drain hose or drain pipe

The internal bore size of the drain hose or drain pipe must be larger than that of the drain port. Arrange the drain line as short as possible.

6. Shaft Loading and Bearing Life

Although K3VL pumps are equipped with bearings that can accept some external thrust and radial forces, application of such loads will affect bearing life. Depending on the load magnitude, the load position, and the load orientation, bearing life may be significantly reduced.

7. Mounting the Pump Above the Tank

Suction line.

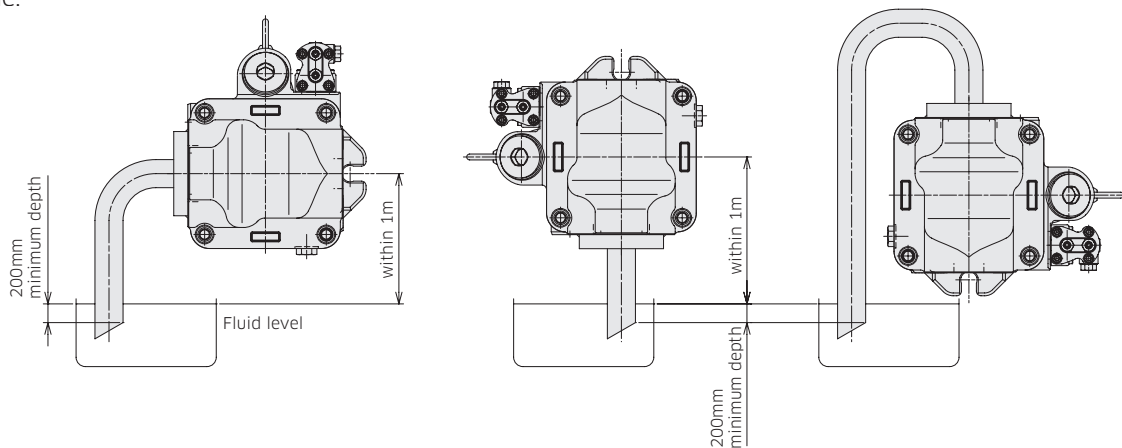

8. Mounting the Pump Vertically (shaft up)

Note: Both the Tair and one case drain port must be used.

For applications requiring vertical installation (shaft up) please remove the Tair bleed plug and connect piping as shown in the illustration below.

When installing the pump in the tank and submerged in the oil, open the drain port and Tair bleed port to provide adequate lubrication to the internal components. See illustration [a].

The oil level in the tank should be higher than the pump-mounting flange as shown in illustration [a] below. If the oil level in the tank is lower than the pump mounting flange then forced lubrication is required through the Tair bleed port 1 ~ 2 l/min.

When installing the pump outside the tank run piping for the drain and Tair bleed ports to tank (see illustration [c]). If the drain or Tair bleed piping rise above the level of oil (see illustration [b]) fill the lines with oil before operation. motor to your national standard is not exceeded.

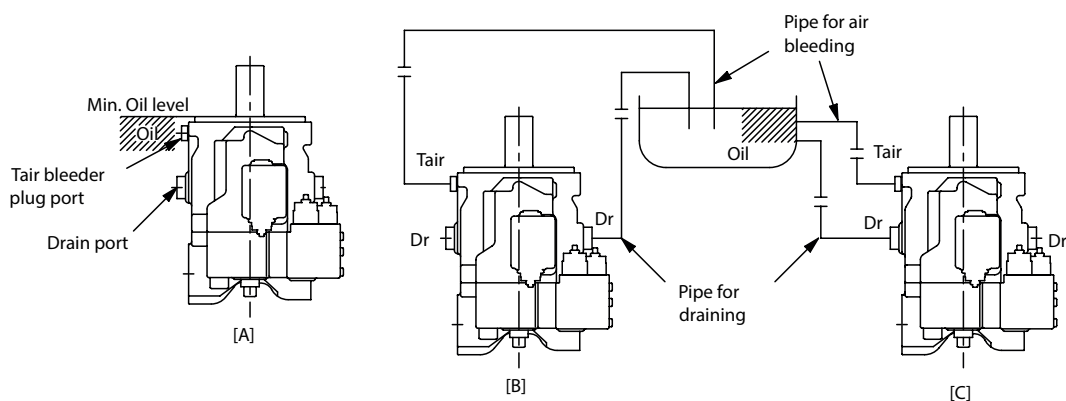

Conversion Factors, Formula and Definition

◆ Conversion Factors

	Formula	Note
Displacement	1 cm ³ = 0.061 in ³	
Pressure	1 MPa = 145 psi	
Flow	1 L/min = 0.264 gpm	US gallon
Torque	1 Nm = 0.74 lb ft	
Power	1 kW = 1.341 hp	
Weight	1 kg = 2.205 lb	

◆ Formula

	Metric system		Imperial system	
Output flow	$Q = q \times N \times \eta_v / 1000$	L/min	$Q = q \times N \times \eta_v / 231$	gal/min
Input torque	$T = q \times \Delta P / 2\pi / \eta_m$	Nm	$T = q \times \Delta P / 24\pi / \eta_m$	lbf ft
Input power	$L = T \times N / 9550 = Q \times \Delta P / 60 / \eta_t$	kW	$L = T \times N / 5252 = Q \times \Delta P / 1714 / \eta_t$	hp

◆ Definition

q	= Pump displacement	cm ³ (in ³)
L	= Input power	kW (hp)
N	= Speed	min ⁻¹ (rpm)
ΔP	= P _d - P _s	MPa (psi)
P _d	= Pump delivery pressure	MPa (psi)
P _s	= Pump suction pressure	MPa (psi)
P _L	= Load sensing pressure	MPa (psi)
P _{dr}	= Pump case pressure	MPa (psi)
P _f	= Power shift pressure	MPa (psi)
P _{sv}	= Servo pressure	MPa (psi)
T	= Input torque	Nm (lbf-ft)
T _{max}	= Maximum input torque	Nm (lbf-ft)
η _v	= Pump volumetric efficiency	
η _m	= Pump mechanical efficiency	
η _t	= Pump total efficiency	

K3VL Series

Swash-plate Axial Piston Pump

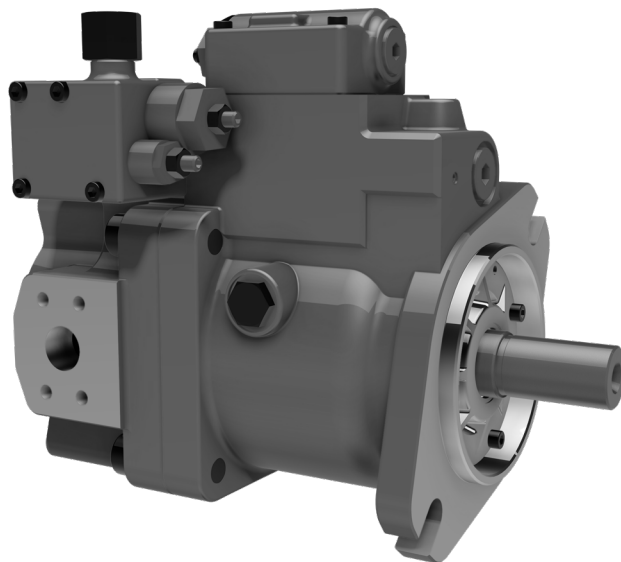

■ General Descriptions

The K3VL series Swash Plate Type Axial Piston Pumps are designed to satisfy the marine, mobile and industrial markets where a medium/high pressure variable displacement pump is required.

K3VL pumps are available in nominal displacements ranging from 28 to 200 cm³/rev with various pressure, torque limiter, and combination of load sensing control options.

Pump Type	Capacity (cm ³ /rev)	Rated pressure (bar)	Maximum self-priming speed (rpm)
K3VL28	28	320	3,000
K3VL45	45	320	2,700
K3VL60	60	250	2,400
K3VL80	80	320	2,400
K3VL112	112	320	2,200
K3VL140	140	320	2,200
K3VL200	200	320	1,900
K3VL200H	200	320	2,200

■ Features

320 bar continuous pressure rating (250 bar for K3VL60)

350 bar peak pressure (280 for K3VL60)

High overall efficiency (>90% peak)

Exceptional self priming capability

SAE and ISO mounting and shaft

Excellent reliability and very long service life

High power to weight ratio

Numerous control options

Highly responsive controls

Low pulsation and noise emissions

Integral unloading or proportional pressure relief valves available

High speed version with integral impeller (K3VL200H)

1

Ordering Code

1-1 Pump Options

1	2		3	4	5	6	7	8	9		10	11	12	13	14	15
K3VL	200	/	B	-	1	N	R	M	M	-	LN	24D	B	/1	-H**	

1. K3VL Series Pump		Preferred product range
K3VL Series, Variable Displacement, Axial Piston, Open Loop Pump	●	AVAILABLE
	◐	NOT AVAILABLE IN COUNTER CLOCKWISE
	○	PLEASE CONTACT KPM UK
	-	NOT AVAILABLE

2. Pump Size										
Maximum Displacement	cm ³ /rev	(H-Impeller)	28	45	60	80	112	140	200	200H
			●	●	●	●	●	●	●	●

3. Design Series									
B	Series	-	●	●	●	●	●	●	●
C	Series	●	-	-	-	-	-	-	-

4. Hydraulic Fluid Type									
-	Mineral Oil, Nitrile seal + Viton Shaft Seal	●	●	●	●	●	●	●	●
V	Viton Seal Throughout	○	○	○	●	●	●	○	○
W	Water Glycol (Nitrile Seal & Nitrile Shaft Seal)	-	○	○	○	○	○	-	-

5. Circuit Type									
1	Open Circuit	●	●	●	●	●	●	●	●

6. Through Drive & Porting									
0	Without Through Drive	◐	◐	◐	◐	◐	◐	◐	-
A	SAE-A Through Drive, Side Ported	●	●	●	●	●	●	●	○
B	SAE-B Through Drive, Side Ported	●	●	●	●	●	●	●	●
BB	SAE-BB Through Drive, Side Ported	-	●	●	●	●	●	●	●
C	SAE-C, 2 Bolt, Through Drive, Side Ported	-	-	-	●	●	●	●	●
C4	SAE-C, 4 Bolt, Through Drive, Side Ported	-	-	-	●	●	●	●	●
CC	SAE-CC, 2 Bolt, Through Drive, Side Ported	-	-	-	-	●	●	●	●
D	SAE-D Through Drive, Side Ported	-	-	-	-	●	●	●	●
E	SAE-E Through Drive, Side Ported	-	-	-	-	-	-	●	●
R	Single Pump, Rear Ported	-	●	●	●	●	●	-	-
N	Single Pump with Steel Cover, Side Ported	●	●	●	●	●	●	●	●

7. Direction of Rotation									
R	Clockwise Rotation	●	●	●	●	●	●	●	●
L	Counter Clockwise Rotation	●	●	●	●	●	●	●	●

1-1 Pump Options

1	2		3	4	5	6	7	8	9		10	11	12	13	14	15
K3VL	200	/	B	-	1	N	R	M	M	-	LN	24D	B	/1	-H**	

8. Mounting Flange & Shaft		28	45	60	80	112	140	200	200H
K	SAE Key & Mount	●	●	●	●	●	●	●	-
M	ISO Key & Mount	-	●	●	●	●	●	-	-
S	SAE Spline & Mount	●	●	●	●	●	●	●	●
R	SAE-C Spline & SAE-D Mount	-	-	-	-	●	●	-	-
C	SAE-C Spline & SAE-C2 Mount	-	-	-	-	●	●	-	-
X	SAE-C Key & SAE-C2 Mount	-	-	-	-	●	●	-	-
Y	SAE-CC Key & SAE-C2 Mount	-	-	-	-	●	●	-	-
W	SAE-CC Spline & SAE-C2 Mount	-	-	-	-	●	●	-	-
F	SAE-F Spline & SAE-E Mount	-	-	-	-	-	-	●	●
T	SAE-B Spline & SAE-B, 2 Bolt Mount	-	●	●	-	-	-	-	-
	SAE-CC Spline & SAE-D, 4 Bolt Mount	-	-	-	-	●	●	-	-

9. Porting Threads									
M	Metric Threads	●	●	●	●	●	●	●	●
S	UNC Thread (Not Available with 'M' ISO Key Shaft & Mount)	●	●	●	●	●	●	●	●

10. Regulator Type									
L0	Load Sense + Pressure Cut-Off (With LS Bleed)	●	●	●	●	●	●	●	●
L1	Load Sense + Pressure Cut-Off (With LS Blocked)	●	●	●	●	●	●	●	●
LM	Load Sense & Intergral Unload (Normally Open)	-	●	●	●	●	●	●	●
LN	Load Sense & Intergral Unload (Normally Closed)	-	●	●	●	●	●	●	●
LV	Load Sense & Intergral Proportional Relief	-	●	●	●	●	●	●	●
LV2	Load Sense & Intergral Proportional Relief	-	●	●	●	●	●	●	●
P0	Pressure Cut-Off	●	●	●	●	●	●	●	●
PM	Pressure Cut-Off & Intergral Unload (Normally Open)	-	●	●	●	●	●	●	●
PN	Pressure Cut-Off & Intergral Unload (Normally Closed)	-	●	●	●	●	●	●	●
PV	Pressure Cut-Off & Intergral Proportional Relief	-	●	●	●	●	●	●	●
PV2	Pressure Cut-Off & Intergral Proportional Relief	-	●	●	●	●	●	●	●
PR	Inverse Proportional Electronic Pressure Control (Only with 24V DC) (see datasheet P-2002/03.17)	○	○	○	○	-	-	-	-

11. Unloader Solenoid									
Blank	For all other options except PN/PM/LN/LM	-	●	●	●	●	●	●	●
115A	115V AC, 50, 60 Hz - DIN 43550 Plug	-	○	○	○	○	○	○	○
230A	230V AC, 50, 60 Hz - DIN 43550 Plug	-	○	○	○	○	○	○	○
12D	12V DC - DIN 43550 Plug	-	●	●	●	●	●	●	●
24D	24V DC - DIN 43550 Plug (Also for use with PR)	-	●	●	●	●	●	●	●

1-1 Pump Options

1	2		3	4	5	6	7	8	9		10	11	12	13	14	15
K3VL	200	/	B	-	1	N	R	M	M	-	LN	24D	B	/1	-H**	

12. Additional Control Options		28	45	60	80	112	140	200	200H
Blank		-	●	●	●	●	●	●	●
A	With Deutsch Connector (Only for PV2/LV2)	-	●	●	●	●	●	●	●
B	With DIN Connector (Only for PV2/LV2)	-	●	●	●	●	●	●	●

13. Additional Control Options									
Blank	Without Additional Control	-	●	●	●	●	●	●	●
/1	Torque Limiter (with provision for torque limiter or displacement control)	-	●	●	●	●	●	●	●
/2	Torque Limiter & Hydraulic Power Shift	-	-	-	●	●	●	●	●
/3	Torque Limiter & Power Shift, 24V DC - DIN 43550 Plug	-	-	-	○	○	○	○	○

14. Torque Limiting & Displacement Control									
Blank	Without Additional Control	-	●	●	●	●	●	●	●
-00	Blanking Plate (only for '/1' type)	-	●	●	●	●	●	●	●
-S#	Special Low Setting Range (available for '/1' type only)	-	●	●	●	●	●	●	●
-L#	Low Setting Range (available for '/1' type only)	-	●	●	●	●	●	●	●
-M#	Medium Setting Range (available for '/1' type only)	-	●	●	●	●	●	●	●
-H#	High Setting Range (available for all '/1', '/2' & '/3' options)	-	●	●	●	●	●	●	●
-E0	Electric Displacement Control (Pilot Pressure Required) AMP Flying Lead 24V DC	-	●	●	●	●	●	●	●
-E1	Electric Displacement Control (Pilot Pressure Required) AMP Moulded 24V DC	-	○	○	○	○	○	○	○
-E2	Electric Displacement Control (Pilot Pressure Required) Deutsch Moulded 24V DC	-	○	○	○	○	○	●	●
-E3	Electric Displacement Control (Pilot Pressure Required) Deutsch Moulded 12V DC	-	○	○	○	●	●	○	○
-Q0	Pilot Operated Displacement Control	-	●	●	●	●	●	●	●

15. Special Suffix									
Contact KPM UK									

2 Technical Information

2-1 Specifications

Pump Model		K3VL28	K3VL45	K3VL60	K3VL80	K3VL112	K3VL140	K3VL200	K3VL200H
Capacity	cc/rev	28	45	60	80	112	140	200	200
Pressure ratings	Rated	320		250	320				
	Peak *1	350		280	350				
Speed ratings	Self prime *2	3,000	2,700	2,400	2,400	2,200	2,200	1,900	2,200
	Max. boosted*3	3,600	3,250	3,000	3,000	2,700	2,500	2,200	2,200
Minimum operating speed	rpm	600							
Case drain pressure	Max. continuous	1							
	Peak	4							
Weight	kg	20	27	25	35	65	65	95	130
Case fill capacity	L	0.6	0.6	0.6	0.8	1.5	1.5	3.0	3.2
Temperature range	°C	-20 to 95							
Viscosity range	cSt	10 to 1,000 - viscosities greater than 200 will require a no load warm up							
Maximum contamination level		ISO 4406 18/15							
Standard SAE mounting flange and shaft	Mounting	2 - bolt SAE B			2 - bolt SAE C	4 - bolt SAE D		4 - bolt SAE E	
	Shaft	SAE B spline or key	SAE B-B spline or key		SAE C spline or key	SAE D spline or key		SAE D spline or spline	
Optional SAE mounting flange and shaft	Mounting	-				2 - bolt SAE C		-	
	Shaft	-	SAE B spline	SAE B spline	-	SAE C or C-C spline or key		SAE F spline	
Standard ISO mounting flange and shaft	Mounting	-	2 bolt ISO 100	2 bolt ISO 100	2 bolt ISO 100	4 bolt ISO 180		-	
	Shaft	-	ISO 25mm key	ISO 25mm key	ISO 25mm key	ISO 45mm key		-	
Input shaft torque rating		refer to table on page 16							
Through drive torque rating (Nm)	SAE A	61	123						
	SAE B	155	290		340				
	SAE B-B	-	290		550				
	SAE C	-			400	700		990	
	SAE C-C	-				700		990	
	SAE D	-				700		990	
	SAE E *4	-							990

*1 : The instant allowable surge pressure as defined by DIN24312. Life and durability of the pump will be affected.

*2 : Steady state inlet pressure should be greater or equal to 0.9 bar absolute.

*3 : Steady state inlet pressure should be greater or equal to 1.3 bar absolute. The maximum boost pressure should not exceed 10 bar.

*4 : SAE E through drive uses the SAE D shaft.

2-1 Specifications (cont)

◆ Input Shaft Torque Ratings

SAE Splined Shafts						
Shaft Designation	SAE B	SAE B-B	SAE C	SAE C-C	SAE D/E	SAE F
Input Torque Rating (Nm)	171	272	552	925	1,470	1,950

SAE Keyed Shafts					
Shaft Designation	SAE B	SAE B-B	SAE C	SAE C-C	SAE D/E
Input Torque Rating (Nm)	145	230	430	700	1,250

ISO Keyed Shafts			
Shaft Designation	ISO 25mm	ISO 32mm	ISO 45 mm
Input Torque Rating (Nm)	145	230	430

Note:

The shaft surface will have a finite life due to wear unless adequate lubrication is provided.

#1 Maximum allowable shaft torques are based on achieving an infinite life for a coupling assembly that is lubricated and completely clamped and utilises the full spline/key length as engagement.

The following points therefore need to be fully considered:-

- i) Lubrication of shaft couplings should be in accordance with the coupling manufacturers instructions.
- ii) The maximum allowable input shaft torque is based on ensuring an infinite life condition by limiting the resultant combined shaft bending and torsional stress.
- iii) This allowable input shaft torque can be further increased dependant on the resultant surface stress at the spline interface which is highly dependant on coupling selection and the provision of adequate spline lubrication.

If you have an application that requires higher input torque please consult KPM UK.

#2 Allowable through drive torques are based on the achieving an infinite life for a fully lubricated coupling and full spline engagement with a mineral oil based anti-wear hydraulic fluid.

2-1 Specifications (cont)

Notes:

Rated Pressure

Pressure at which life and durability will not be affected.

Peak Pressure

The instant allowable surge pressure as defined by BS ISO 2944:2000. Life and durability however will be shortened.

Maximum Self Priming Speed

Values are valid for an absolute suction pressure of 0.9 bar. If the flow is reduced and the inlet pressure is increased the speed may also be increased.

Maximum Boosted Speed

Values stated are the absolute maximum permitted speed for which an increased inlet pressure will be required.

Weight

Approximate dry weights, dependant on exact pump type.

Hydraulic Fluid

Mineral anti wear hydraulic fluid - for other fluid types please consult KPM UK.

Viscosity Range

If viscosity is in range 200 to 1,000 cSt, then warming up is necessary before commencing full scale running.

2-2 Technical Data (cont)

Working Fluid Types

Anti-Wear Type Hydraulic fluid

It is generally recommended to use an anti-wear hydraulic fluid like mineral oil when the operating pressure exceeds 206 bar.

Fire-resistant Fluids

Some kind of fire-resistant fluids require special materials for seals, paint and metal finishing. Please consult KPM UK and provide details of the particular fluid specification and the working conditions so that any special requirements can be ascertained.

In general, fire-resistant fluids have a low viscosity index and their viscosity also changes significantly with operating temperature and service life. For this reason, the circuit should be provided with an adequately sized cooler or forced cooling so that temperatures can be stabilised. Due to the inherent water content of some of these fluids the minimum allowable suction pressure will be higher than that of an equivalent mineral oil and so needs to be fully evaluated by KPM UK. The following table provides an overview of the precautions and characteristics that can be expected with these types of fluids.

Fluid Type Parameter	Mineral Oil	Water Glycol
Maximum Pressure (bar)	320	210
Recommended Temperature Range (deg C)	20 ~ 60	20 ~ 60
Cavitation susceptibility	○	△
Expected life expectancy compared to mineral oil	100%	20%

○ recommended △ usable (higher density)

Pump Start Up Precautions

Piping & Circuit Checking

Check to see that the piping and full hydraulic circuit is completed and that any gate valves etc. are open.

Direction of Rotation

Check to ensure that direction of rotation is correct and that the inlet and delivery lines are connected correctly.

Start Up

Jog start the motor and check once more for correct rotation. Run the pump unloaded for a period to ensure that all residual air within the system is released. Check for external leakage, abnormal noise and vibrations.

End of Life

The pump unit, hydraulic fluid and packaging must be disposed of carefully to avoid pollution to the environment. The pump unit must be completely empty upon disposal, it must be disposed of according to national regulations and you must also follow safety information for disposal of the hydraulic fluid.

All individual parts of the pump unit must be recycled. Separate the pump unit parts according to: cast parts, steel, aluminium, non-ferrous metal, electronic waste, plastic, and seals.

2-3 Performance Data

K3VL28

◆ Pump Efficiency (%)

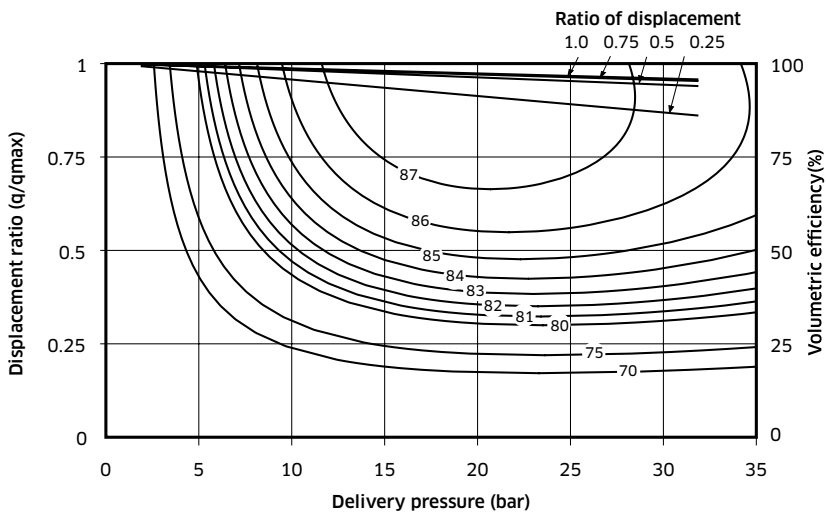

◆ Self Priming Capability

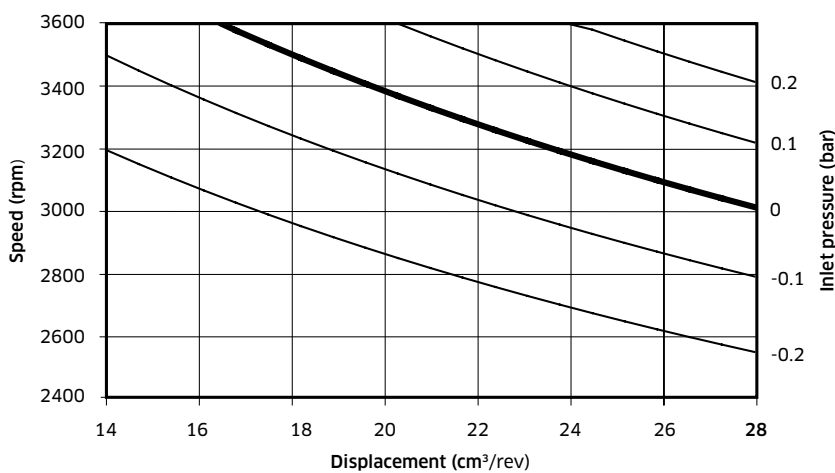

Performance Note:

All performance curves are based on the following conditions:

- 1,500 rpm
- ISO VG46 mineral oil
- 50°C oil temperature
- Atmospheric inlet condition (0 bar)

2-3 Performance Data (cont)

K3VL45

◆ Pump Efficiency (%)

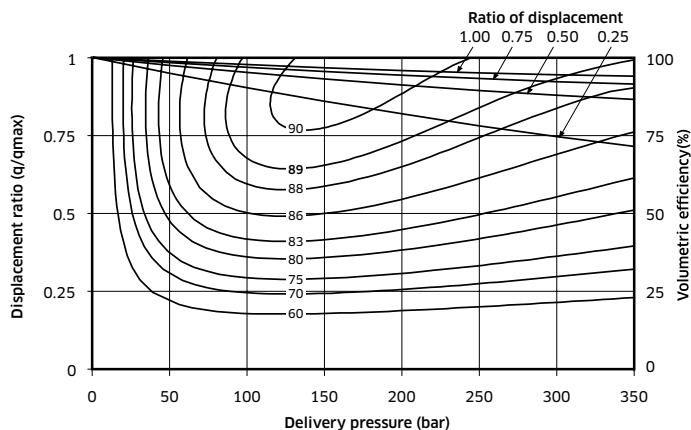

◆ Self Priming Capability

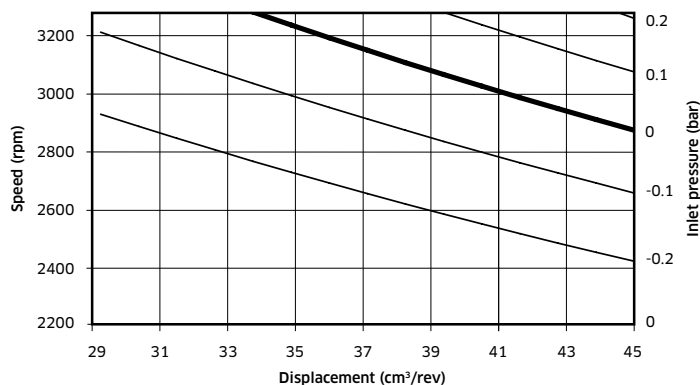

◆ Noise Levels

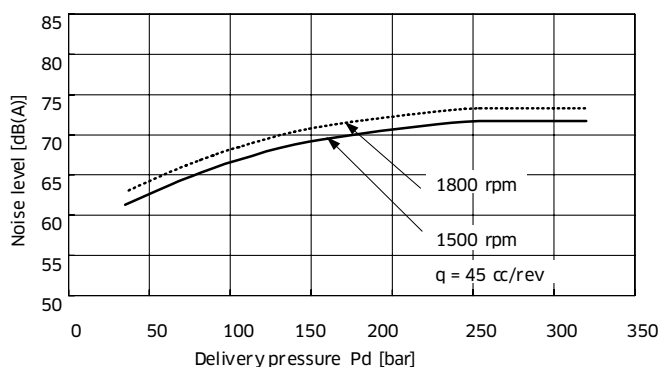

Noise level measured in an anechoic chamber where distance from microphone to pump is 1 metre. Measurement accuracy +/- 2 dB(A)

Performance Note:

All performance curves are based on the following conditions:

- 1,500 rpm
- ISO VG46 mineral oil
- 50°C oil temperature
- Atmospheric inlet condition (0 bar)

2-3 Performance Data (cont)

K3VL60

◆ Pump Efficiency (%)

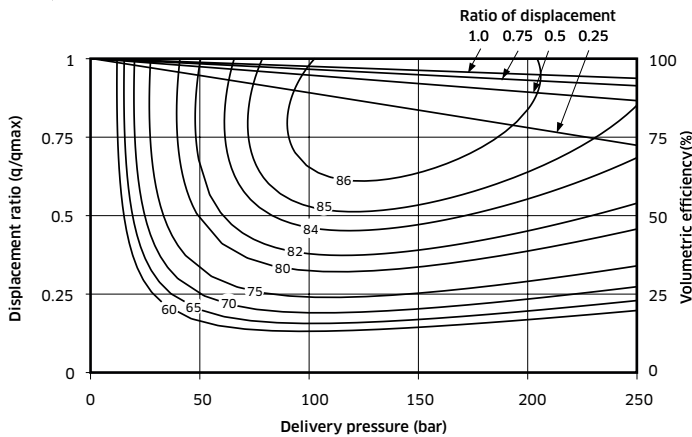

◆ Self Priming Capability

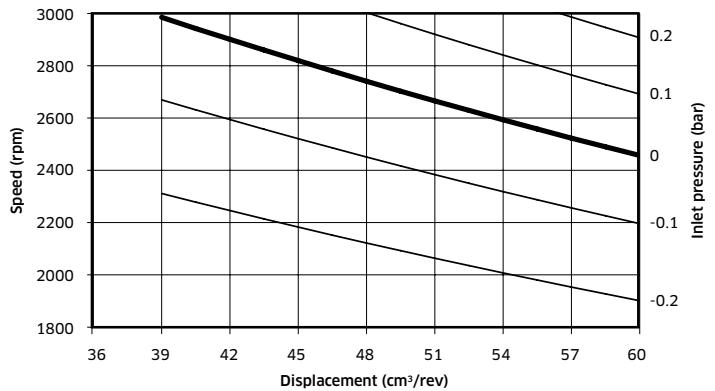

◆ Noise Levels

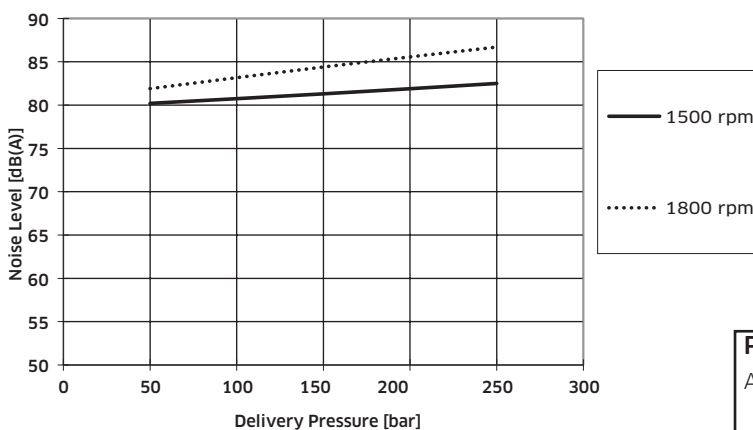

Performance Note:

All performance curves are based on the following conditions:

- 1,500 rpm
- ISO VG46 mineral oil
- 50°C oil temperature
- Atmospheric inlet condition (0 bar)

2-3 Performance Data (cont)

K3VL80

◆ Pump Efficiency (%)

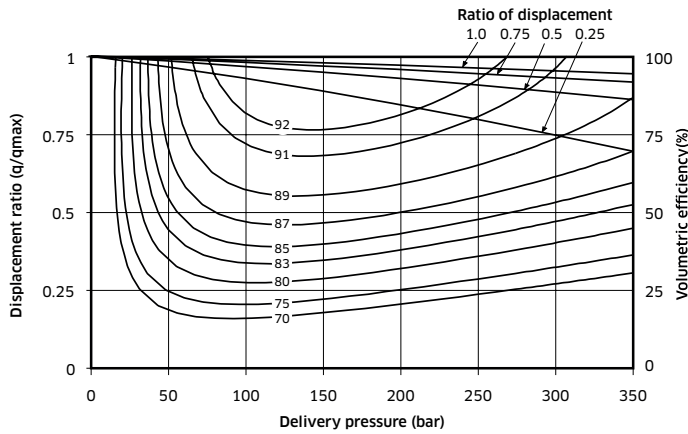

◆ Self Priming Capability

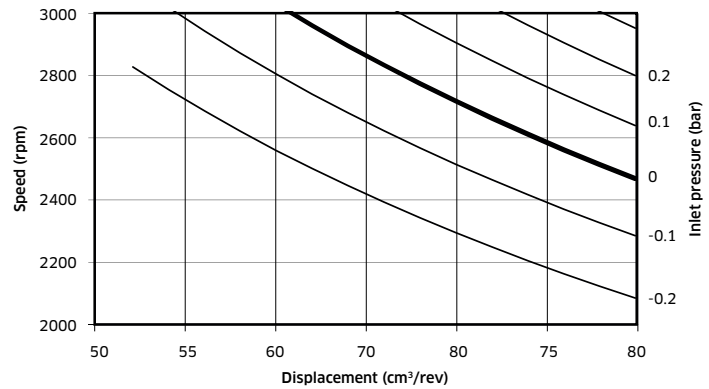

◆ Noise Levels

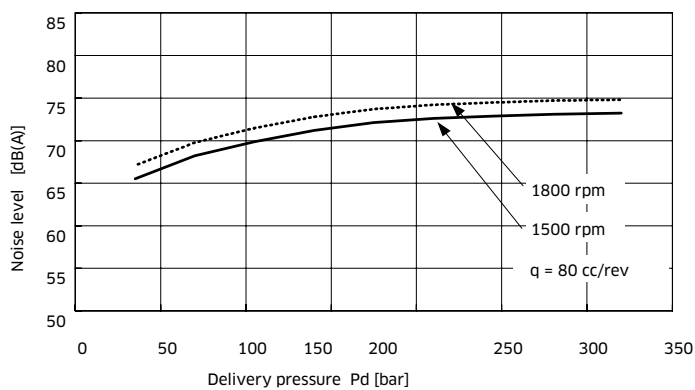

Noise level measured in an anechoic chamber where distance from microphone to pump is 1 metre. Measurement accuracy +/- 2 dB(A)

Performance Note:

All performance curves are based on the following conditions:

- 1,500 rpm
- ISO VG46 mineral oil
- 50°C oil temperature
- Atmospheric inlet condition (0 bar)

2-3 Performance Data (cont)

K3VL112

◆ Pump Efficiency (%)

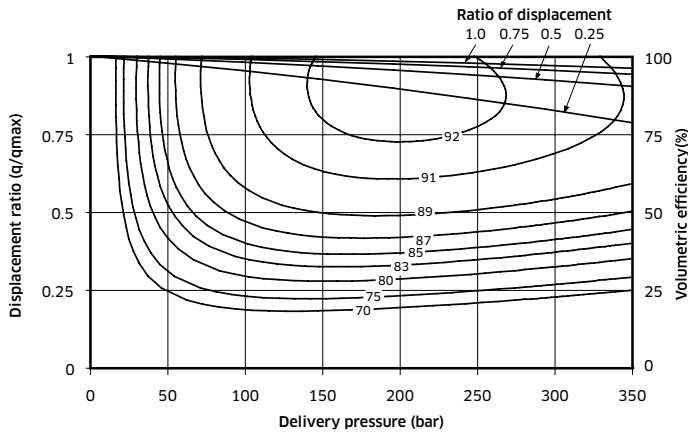

◆ Self Priming Capability

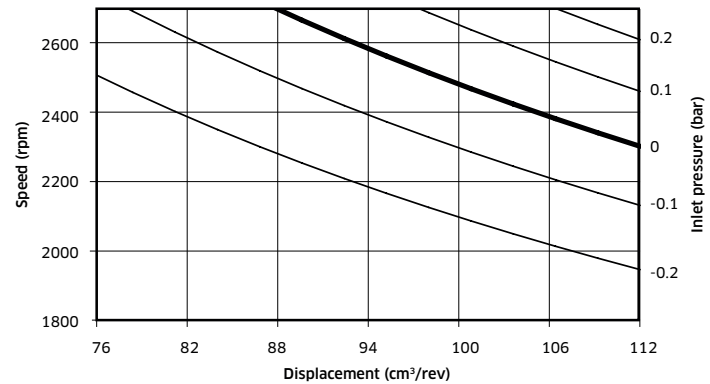

◆ Noise Levels

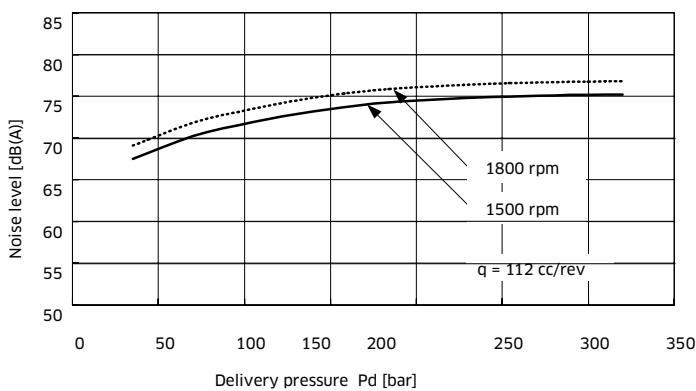

Noise level measured in an anechoic chamber where distance from microphone to pump is 1 metre. Measurement accuracy $\pm 2 \text{ dB(A)}$

Performance Note:

All performance curves are based on the following conditions:

- 1,500 rpm
- ISO VG46 mineral oil
- 50°C oil temperature
- Atmospheric inlet condition (0 bar)

2-3 Performance Data (cont)

K3VL140

◆ Pump Efficiency (%)

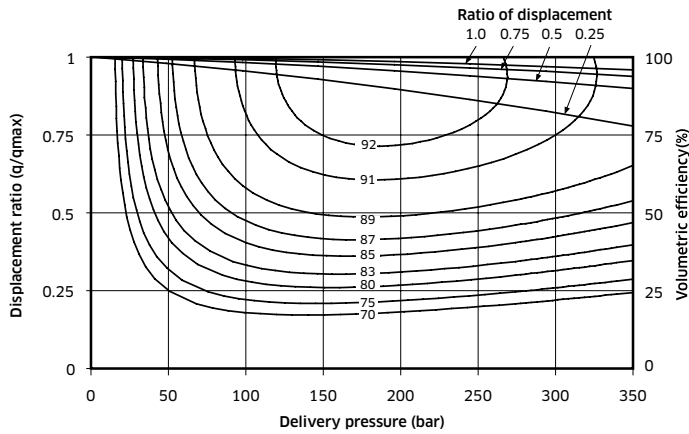

◆ Self Priming Capability

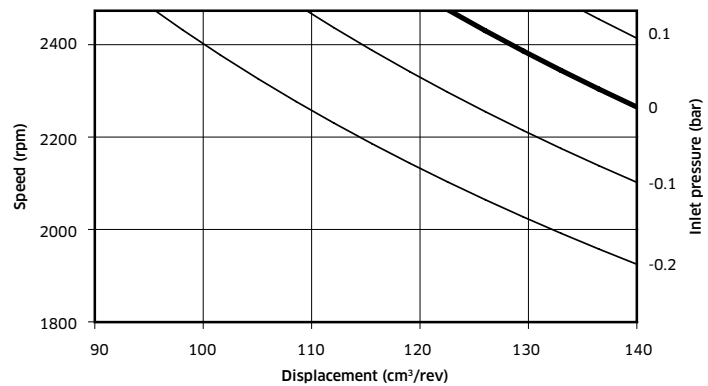

◆ Noise Levels

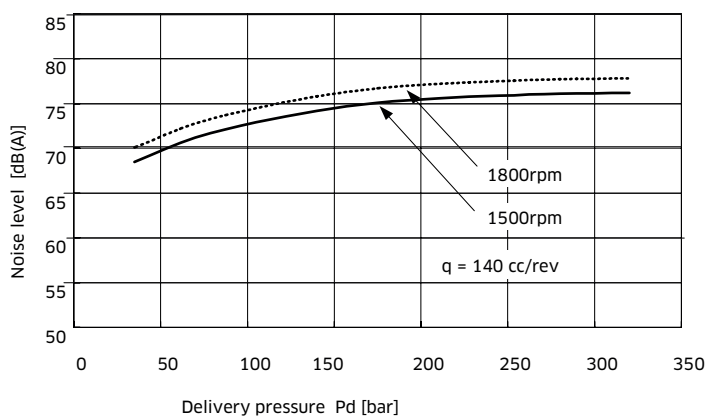

Noise level measured in an anechoic chamber where distance from microphone to pump is 1 metre. Measurement accuracy +/- 2 dB(A)

Performance Note:

All performance curves are based on the following conditions:

- 1,500 rpm
- ISO VG46 mineral oil
- 50°C oil temperature
- Atmospheric inlet condition (0 bar)

2-3 Performance Data (cont)

K3VL200

◆ Pump Efficiency (%)

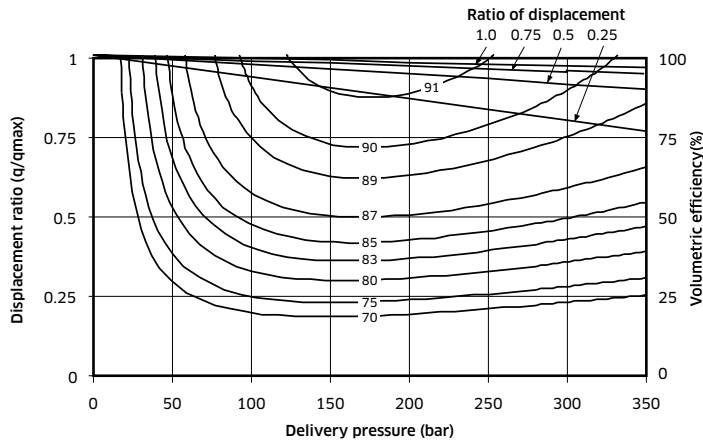

◆ Self Priming Capability

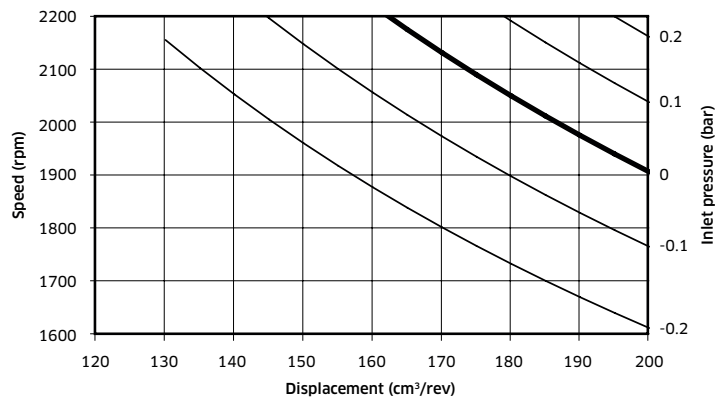

◆ Noise Levels

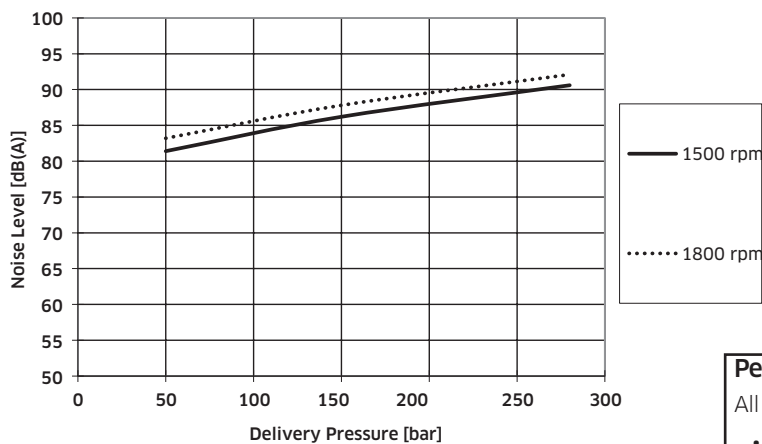

Noise level measured in an anechoic chamber where distance from microphone to pump is 1 metre. Measurement accuracy +/- 2 dB(A)

Performance Note:

All performance curves are based on the following conditions:

- 1,500 rpm
- ISO VG46 mineral oil
- 50°C oil temperature
- Atmospheric inlet condition (0 bar)

2-4 Radial Loading Capacity

No axial shaft loading possible, radial loading is achievable but in specific orientation:-

Radial shaft loading can be allowed provided that its orientation is such that the front bearing takes the additional load (see diagram below).

Note: In this case bearing life will be reduced.

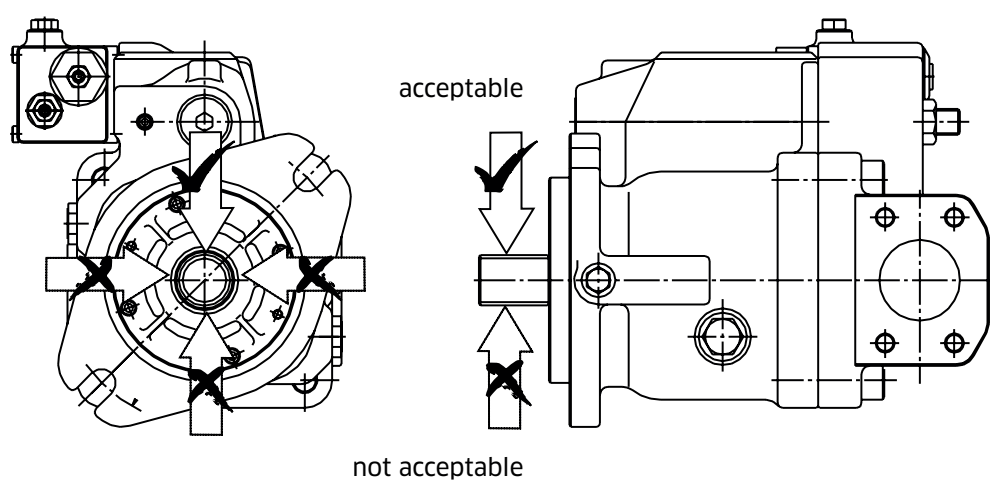

2-5 Functional Description of Regulator



Key to Hydraulic Circuit Annotations	
Annotations	Description
A	Main pump delivery
A1	Auxillary pump delivery
B1	Gear pump inlet
B	Main pump inlet
Dr	Drain
Pc	Remote pilot port, Pressure compensator
PI	Pilot port displacement control
PL	Load sense port
Tair	Air bleed port
P_f	Hydraulic power shift
P_{sv}	Servo assist

Regulator Code	Control Curves	Hydraulic Circuit
<p>L0/L1 Load Sense and Pressure Cut-off</p> <p>Pump displacement is controlled to match the flow requirement as a function of the system differential pressure (load pressure vs delivery pressure). In addition, there is a pressure cut off function incorporated into the control with the L1 option, the bleed-off orifice R4 is plugged.</p>		
<p>LN Load Sense and Pressure Cut-off with Integrated Unloading Valve (Normally Closed)</p> <p>An integrated unloading valve is sandwiched between the Load Sense regulator and pump to effectively de-stroke and swashplate when an electric signal is provided.</p>		

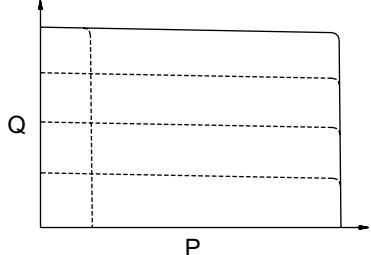
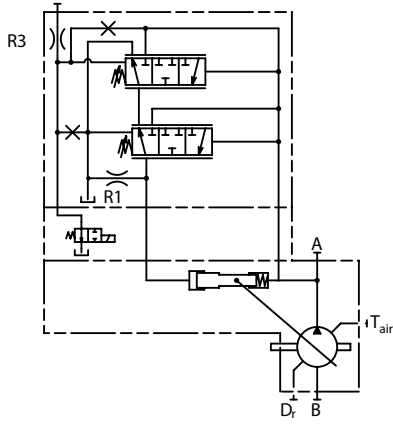
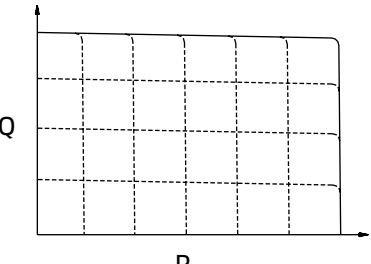
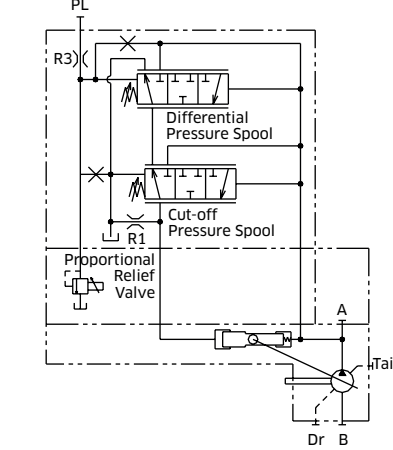
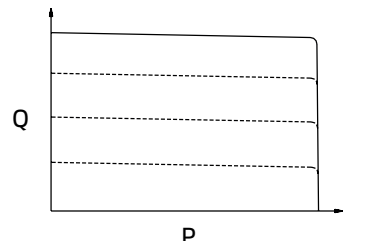
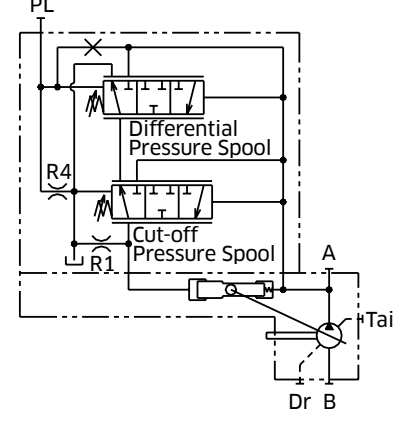
2-5 Functional Description of Regulator (cont)

Regulator Code	Control Curves	Hydraulic Circuit
<p>LM Load Sense and Pressure Cut-off with Integrated Unloading Valve (Normally Open)</p> <p>An integrated unloading valve is sandwiched between the Load Sense regulator and the pump. An electrical signal must be provided to prevent the Load Sense line from draining.</p>		
<p>LV/LV2 Load Sense and Pressure Cut-off with Integrated Proportional Relief Valve</p> <p>An integrated proportional relief valve is sandwiched between the Load Sense regulator and pump to control the maximum pressure setting by varying an electric signal to the valve.</p> <p>A separate amplifier is required.</p> <p>Note: LV has improved control characteristic.</p>		
<p>L0/L1 Load Sense and Pressure Cut-off with Torque Limiting</p> <p>L0/L1 control functions as previously noted. In response to a rise in delivery pressure the swashplate angle is decreased, restricting the input torque. This regulator prevents excessive load against the prime mover.</p> <p>The torque limit control module is comprised of two springs that oppose the spool force generated by the system pressure. By turning an outer and inner spring adjustment screw, the appropriate input torque limit can be set.</p>		

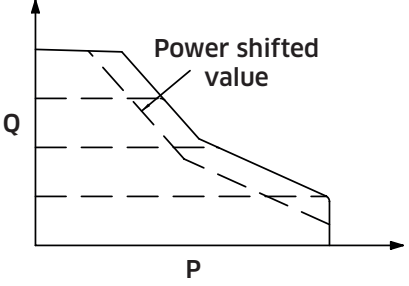
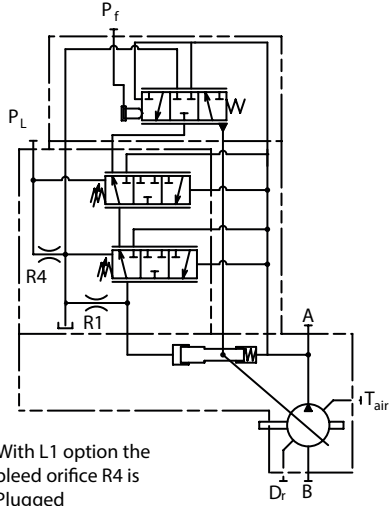
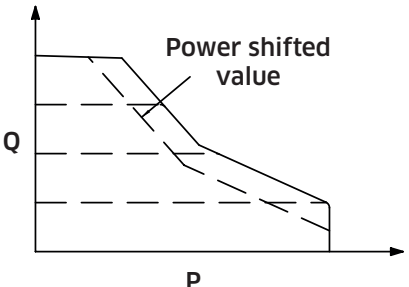
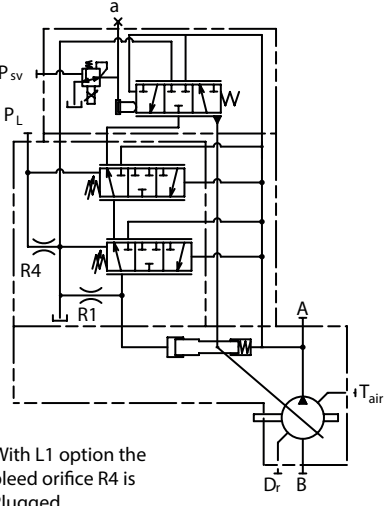
2-5 Functional Description of Regulator (cont)

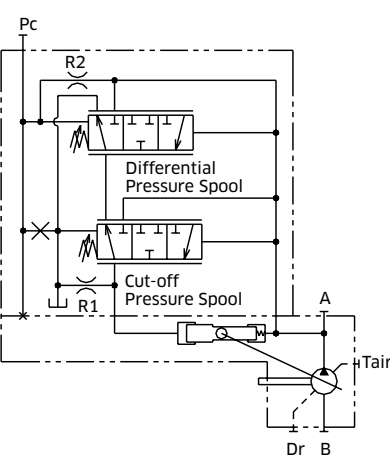
Regulator Code	Control Curves	Hydraulic Circuit
<p>/2-** Hydraulic Power Shift with Load Sensing</p> <p>This function, as with the /1 type can be used with Pressure compensation, Load sense and additional control options such as unloader functions. The control has the same function as standard torque limit option. In response to a rise in delivery pressure the swashplate angle is reduced, restricting input torque.</p> <p>However if a pilot pressure is applied to the Pf port on the regulator, the torque setting can be further reduced proportionally to the pilot pressure applied. The input torque can be reduced by approximately 40% .</p>		 <p>With L1 option the bleed orifice R4 is Plugged</p>
<p>/3-** Electronic Power Shift with Load Sensing</p> <p>This function, as with the /1 type can be used with Pressure compensation, Load sense and additional control options such as unloader functions. The control has the same function as standard torque limit. In response to a rise in delivery pressure the swashplate angle is reduced, restricting input torque.</p> <p>However a constant pressure of 40 bar is required, applied to the Psv port of the regulator. The torque setting can be further reduced proportionally to a 24VDC electrical signal applied to the proportional valve on the regulator.</p>		 <p>With L1 option the bleed orifice R4 is Plugged</p>
<p>P0 Pressure Cut-off</p> <p>As system pressure rises to the cutoff setting, the swashplate de-strokes to prevent the system pressure from exceeding the compensator setting. It is imperative that a safety relief valve be installed in the system.</p> <p>Note: By connecting the Pc port to a remote pressure control, variable pump pressure control can be achieved.</p>		

2-5 Functional Description of Regulator (cont)

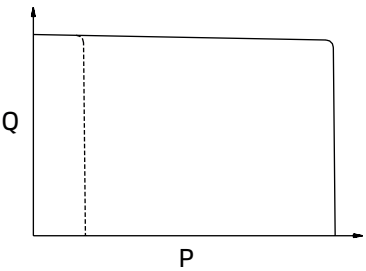
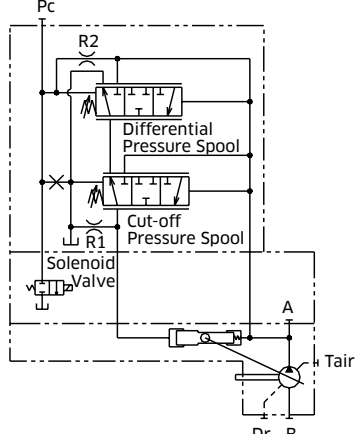
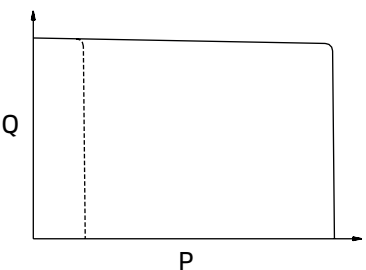
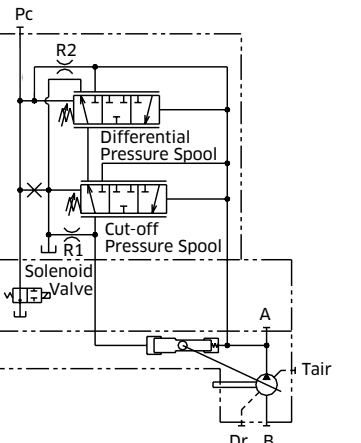
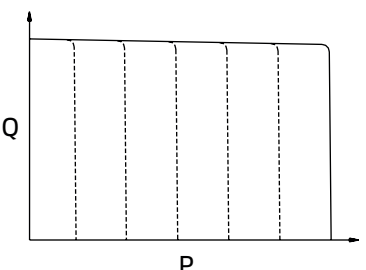
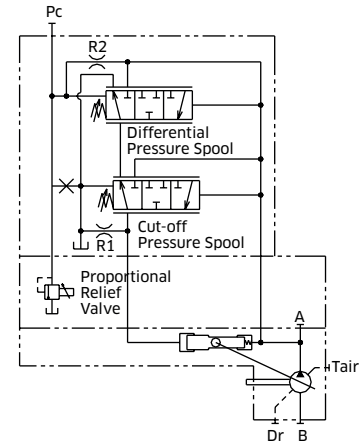
Regulator Code	Control Curves	Hydraulic Circuit
<p>PN Pressure Cut-off with Integrated Unloading Valve (Normally Closed)</p> <p>An integrated unloading valve is sandwiched between the Pressure Cut-off regulator and pump to effectively de-stroke the swashplate when an electric signal is provided.</p>		
<p>PM Pressure Cut-off with Integrated Unloading Valve (Normally Open)</p> <p>An integrated unloading valve is sandwiched between the Pressure Cut-off regulator and the pump. An electrical signal must be provided to prevent the Pc line from draining.</p>		
<p>PV/PV2 Pressure Cut-off with Integrated Proportional Relief Valve</p> <p>An integrated proportional relief valve is sandwiched between the Pressure Cut-off regulator and the pump to control the maximum pressure setting by varying an electric signal to the valve. A separate amplifier is required. Note: PV has improved control characteristic</p>		

2-5 Functional Description of Regulator (cont)

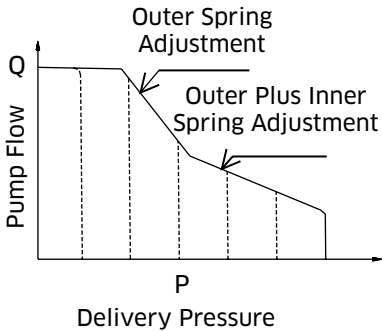
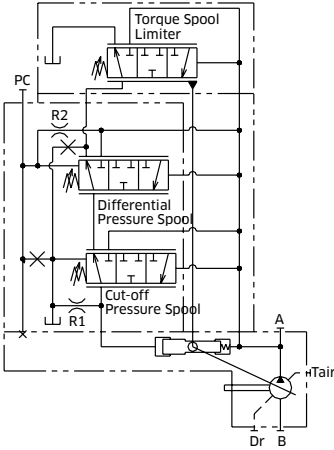
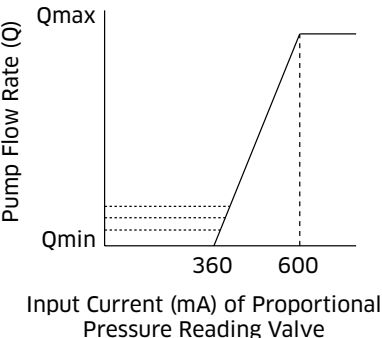
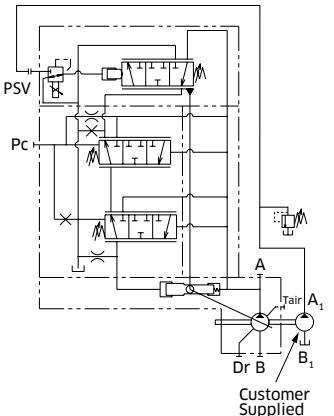
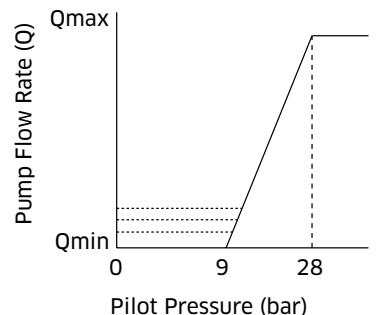
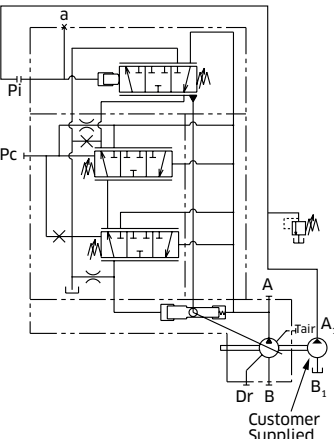
Regulator Code	Control Curves	Hydraulic Circuit
<p>P0/1 Pressure Cut-off with Torque Limiting</p> <p>P0/1 control functions as previously noted. In response to a rise in delivery pressure the swashplate angle is reduced, restricting the input torque. This regulator prevents excessive load against the prime mover.</p> <p>Note: By connecting the Pc port to a remote pressure control, variable pump pressure control can be achieved.</p>		
<p>/1-E0 Electrical Displacement Control</p> <p>Varying the input current signal to the pump controller's electronic proportional pressure reducing valve (PPRV) allows the user to control the pump displacement. As the current signal to the PPRV increases, the pump displacement increases proportionally.</p> <p>Note: An external pressure supply of 40 bar is required at the PSV Port (50 bar max).</p>		
<p>/1-Q0 Pilot Operated Displacement Control</p> <p>Varying the input pressure signal to the Pi port allows the user to control the pump displacement. As the pressure signal to the Pi increases, the pump displacement increases proportionally.</p> <p>Note: An external pressure supply of up to 40 bar is required at the Pi Port (50 bar max).</p>		

2-5 Functional Description of Regulator (cont)

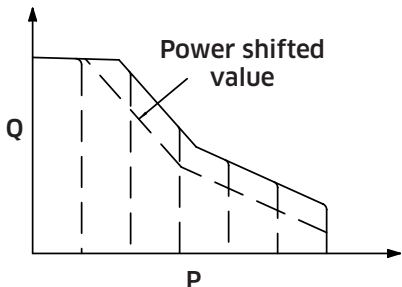
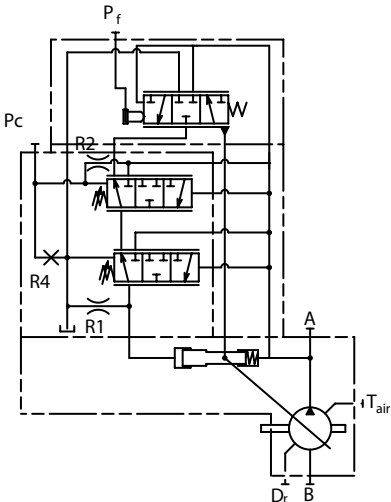
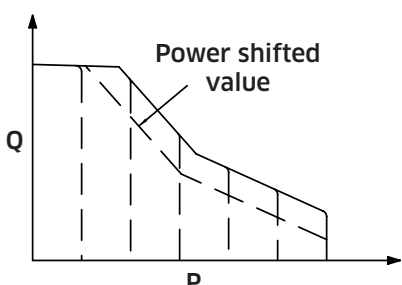
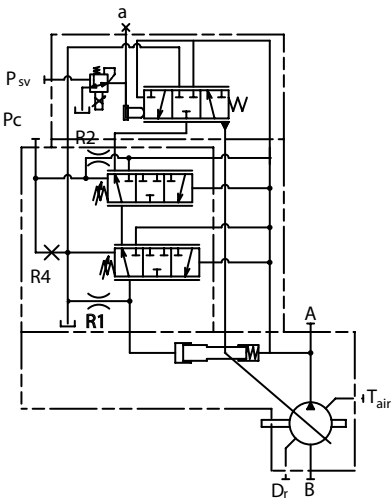
Regulator Code	Control Curves	Hydraulic Circuit
<p>/2-** Hydraulic Power Shift with Pressure Compensation</p> <p>This function, as with the /1 type can be used with Pressure compensation, Load sense and additional control options such as unloader functions. The control has the same function as standard torque limit option. In response to a rise in delivery pressure the swashplate angle is reduced, restricting input torque. However if a pilot pressure is applied to the P_f port on the regulator, the torque setting can be further reduced proportionally to the pilot pressure applied. The input torque can be reduced by approximately 40% .</p>		
<p>/3-** Electronic Power Shift with Pressure Compensation</p> <p>This function, as with the /1 type can be used with Pressure compensation, Load sense and additional control options such as unloader functions. The control has the same function as standard torque limit. In response to a rise in delivery pressure the swashplate angle is reduced, restricting input torque. However a pilot pressure of 40 bar is required, applied to the PSV port of the regulator. The torque setting can be further reduced proportionally to a 24VDC electrical signal applied to the proportional signal valve on the regulator.</p>		

2-6 Torque Limiter Settings

The following tables show the power limitation at various electric motor speeds for a specific frame size of pump. When selecting a control setting please ensure that the power limitation of a particularly sized electric motor to your national standard is not exceeded.

K3VL45				
KW	970	1150	1450	1750
3.7	S3	S4	-	-
5.5	L3	S1	S3	S4
7.5	L1	L2	L4	S2
11	M1	M3	L1	L2
15	H3	H4	M2	M4
18.5	-	H2	H4	M2
22	-	-	H3	H4
30	-	-	-	H1
37	-	-	-	-
45	-	-	-	-
55	-	-	-	-
75	-	-	-	-
90	-	-	-	-
110	-	-	-	-
132	-	-	-	-

K3VL60				
KW	970	1150	1450	1750
3.7	-	-	-	-
5.5	S2	S2	-	-
7.5	L4	S1	S3	-
11	M4	L2	S1	S2
15	M2	M3	L2	L3
18.5	H2	M1	M3	L1
22	-	H2	M2	M3
30	-	-	H2	H3
37	-	-	-	H1
45	-	-	-	-
55	-	-	-	-
75	-	-	-	-
90	-	-	-	-
110	-	-	-	-
132	-	-	-	-

K3VL80				
KW	970	1150	1450	1750
3.7	-	-	-	-
5.5	S2	S4	-	-
7.5	L6	S1	S3	-
11	L2	L4	L6	S1
15	M4	L1	L3	L5
18.5	M1	M3	L1	L3
22	H3	M1	M4	L1
30	H1	H2	H4	M2
37	-	-	H2	H4
45	-	-	H1	H2
55	-	-	-	H1
75	-	-	-	-
90	-	-	-	-
110	-	-	-	-
132	-	-	-	-

K3VL112				
KW	970	1150	1450	1750
3.7	-	-	-	-
5.5	-	-	-	-
7.5	S5	S6	-	-
11	S1	S3	S5	S6
15	L3	L4	S2	S4
18.5	M4	L2	L4	S2
22	M2	M4	L3	L4
30	H4	M1	M3	L1
37	H2	H3	M1	M3
45	-	H2	H4	M1
55	-	-	H2	H4
75	-	-	-	H1
90	-	-	-	-
110	-	-	-	-
132	-	-	-	-

K3VL140				
KW	970	1150	1450	1750
3.7	-	-	-	-
5.5	-	-	-	-
7.5	-	-	-	-
11	S2	S4	-	-
15	L6	S1	S3	-
18.5	L3	L5	S1	S3
22	L1	L3	L6	S1
30	M2	M3	L2	L4
37	H4	M1	M3	L2
45	H2	H4	M2	M3
55	-	H2	H4	M2
75	-	-	H1	H3
90	-	-	-	H1
110	-	-	-	-
132	-	-	-	-

K3VL200				
KW	970	1150	1450	1750
3.7	-	-	-	-
5.5	-	-	-	-
7.5	-	-	-	-
11	-	-	-	-
15	-	-	-	-
18.5	S1	-	-	-
22	L4	S1	-	-
30	L2	L3	L5	S2
37	M3	L1	L3	L5
45	M1	M3	L2	L3
55	H5	M1	M3	L2
75	H1	H3	H6	M2
90	-	H1	H4	H6
110	-	-	H2	H4
132	-	-	-	H2

2-6 Torque Limiter Settings (cont)

◆ Torque Limiter Control - Setting Table

K3VL frame size	Prime Mover Input Torque (Nm)																														
	30	36	41	46	49	53	61	73	82	91	100	107	121	146	154	163	182	200	216	246	298	307	367	409	450	492	540	610	618	711	752
45	S4	S3	S2	S1	L4	L3	L2	L1	M4	M3	M2	M1	H4	H3	H2	H1	-	-	-	-	-	-	-	-	-	-	-	-	-	-	-
60	-	-	-	S4	S3	S2	S1	L4	L3	L2	L1	M4	M3	M2	H3	H2	H1	-	-	-	-	-	-	-	-	-	-	-	-	-	-
80	-	-	-	S4	S3	S2	S1	L6	L5	L4	L3	L2	L1	M4	M3	M2	M1	H4	H3	H2	H1	-	-	-	-	-	-	-	-	-	-
112	-	-	-	-	-	-	S6	S5	S4	S3	S2	S1	L4	L3	L2	L1	M4	M3	M2	M1	H4	H3	H2	H1	-	-	-	-	-	-	-
140	-	-	-	-	-	-	-	-	S4	S3	S2	S1	L6	L5	L4	L3	L2	L1	M3	M2	M1	H4	H3	H2	H1	-	-	-	-	-	-
200 & 200H	-	-	-	-	-	-	-	-	-	-	-	-	-	-	S2	S1	L5	L4	L3	L2	L1	M3	M2	M1	H6	H5	H4	H3	H2	H1	

Note: Highlighted options show power shift

◆ Power Shift Control - Setting Table

/2 Hydraulic Spring Setting		K3VL80				K3VL112				K3VL140				K3VL200(H)					
		H4	H3	H2	H1	H4	H3	H2	H1	H4	H3	H2	H1	H6	H5	H4	H3	H2	H1
Pf Pressure (bar)	0	200	216	246	298	298	307	367	409	367	409	450	492	492	540	610	618	711	752
	10	167	183	209	252	252	255	309	349	309	349	383	421	421	453	517	524	610	648
	20	138	152	175	210	210	208	256	292	256	292	322	356	356	374	432	439	517	553
	30	111	123	145	173	173	167	209	241	209	241	266	298	298	303	355	361	433	465

/3 Electric Spring Setting		K3VL80				K3VL112				K3VL140				K3VL200(H)					
		H4	H3	H2	H1	H4	H3	H2	H1	H4	H3	H2	H1	H6	H5	H4	H3	H2	H1
Current (mA)	0	200	216	246	298	298	307	367	409	367	409	450	492	492	540	610	618	711	752
	336	167	183	209	252	252	255	309	349	309	349	383	421	421	453	517	524	610	648
	473	138	152	175	210	210	208	256	292	256	292	322	356	356	374	432	439	517	553
	595	111	123	145	173	173	167	209	241	209	241	266	298	298	303	355	361	433	465

2-7 Installation

◆ Moment of Inertia and Torsional Stiffness

Frame Size	Moment of Inertia		Torsional Stiffness (N m/rad)
	I (kg.m ²)	GD ² (kgf.m ²)	
K3VL28	2.09x10 ⁻³	8.36-10 ⁻³	2.20 x 10 ⁴
K3VL45	3.85x10 ⁻³	1.54-10 ⁻²	3.59 x 10 ⁴
K3VL60	3.83x10 ⁻³	1.53-10 ⁻²	3.59 x 10 ⁴
K3VL80	7.30x10 ⁻³	2.92-10 ⁻²	4.83 x 10 ⁴
K3VL112	2.02x10 ⁻²	8.06-10 ⁻²	9.33 x 10 ⁴
K3VL140	2.02x10 ⁻²	8.06-10 ⁻²	9.33 x 10 ⁴
K3VL200	4.58x10 ⁻²	1.83-10 ⁻¹	1.54 x 10 ⁵
K3VL200H	4.58x10 ⁻²	1.83-10 ⁻¹	1.54 x 10 ⁵

◆ Through Drive Limitations

Pump over all length (LPX) (mm)	
Frame size	Single pump type N
K3VL28	219
K3VL45	244
K3VL60	244
K3VL80	272
K3VL112	307
K3VL140	307
K3VL200	359
K3VL200H	424

Frame size	Maximum Permissible Bending Moment
K3VL28	137
K3VL45	137
K3VL60	137
K3VL80	244
K3VL112	462
K3VL140	462
K3VL200	930
K3VL200H	930

2-7 Installation (cont)

◆ Through Drive Limitations (cont)

Frame size	Pump approx weight (MPX)(Kg)	
	Single pump type N	
	Without Torque Limitor	With Torque Limitor
K3VL28	22	na
K3VL45	28	30
K3VL60	28	30
K3VL80	38	40
K3VL112	69	71
K3VL140	69	71
K3VL200	103	105
K3VL200H	142	140

Frame size	Pump CofG from mount (Lx) (mm)
	Single pump type N
K3VL28	115
K3VL45	120
K3VL60	120
K3VL80	130
K3VL112	150
K3VL140	150
K3VL200	190
K3VL200H	223

Adaptor Kits Weights (MAX) & Width (LAX)			
Frame Size	Adaptor Kit	Weight (MAX) Kg	Width (LAX) mm
K3VL28	SAE 'A'	0	0
	SAE 'B'	2	20
K3VL45 & 60	SAE 'A'	0	0
	SAE 'B' & 'BB'	2	20
K3VL80	SAE 'A'	0	0
	SAE 'B' & 'BB'	3	20
	SAE 'C', 'CC' & 'C4'	4	24.5
K3VL112 & 140	SAE 'A'	0	0
	SAE 'B' & 'BB'	3	25
	SAE 'C', 'CC' & 'C4'	5	30
	SAE 'D'	10	43
K3VL200	SAE 'A'	1	6
	SAE 'B' & 'BB'	8	25
	SAE 'C', 'CC' & 'C4'	8	30
	SAE 'D'	10	38
	SAE 'E'	15	38

Apart from predefined maximum throughput limitations, one must also ensure that to prevent a possible excessive bending moment occurring that the maximum combined bending moment of the combination is not exceeded as determined in the following expression.

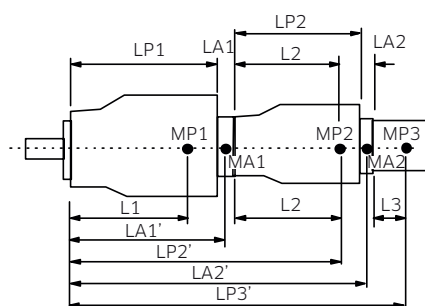

MPX = mass of pump [kg]
 LPX = length of pump [mm]
 Lx = distance of CofG from pump mounting face [mm]
 MAX = mass of adaptor kit [kg]
 LAX = width of adaptor kit [mm]

$$\text{Bending Moment} = \frac{((L1.mP1) + (LA1'.mA1) + (LP2'.mP2) + (LA2'.mA2) + LP3'.mP3) + \dots}{102} [\text{Nm}]$$

$$\frac{((L1.mP1) + (LP1+(LA1/2)).mA1 + (LP1+LA1+L2).mP2 + (LP1+LA1+LP2(LA2/2)).mA2 + (LP1+LA1+LP2+LA2).mP3) + \dots)}{102}$$

2-7 Installation (cont)

◆ Response times

Pressure Cut-off Dynamic Response

50 to 280 bar

	$t_{\text{off-stroke}}$	$t_{\text{on-stroke}}$
Unit	mS	
K3VL28	20	40
K3VL45/60	60	100
K3VL80	95	170
K3VL112/140	90	140
K3VL200/H	110	210

Test conditions:

Pump speed = 1800 rpm
 Inlet Condition = 0 bar
 Oil Type = ISO VG46
 Oil Temperature = 50°C
 Compressed oil volume = 5 litres

220 to 280 bar

	$t_{\text{off-stroke}}$	$t_{\text{on-stroke}}$
Unit	mS	
K3VL28	20	40
K3VL45/60	60	70
K3VL80	100	110
K3VL112/140	100	120
K3VL200/H	110	220

Test conditions:

Pump speed = 1800 rpm
 Inlet Condition = 0 bar
 Oil Type = ISO VG46
 Oil Temperature = 50°C
 Compressed oil volume = 5 litres

Load Sensing Dynamic Response

20 to 280 bar

	$t_{\text{off-stroke}}$	$t_{\text{on-stroke}}$
Unit	mS	
K3VL28	20	70
K3VL45/60	20	115
K3VL80	55	155
K3VL112/140	55	195
K3VL200/H	65	190

Test conditions:

Pump speed = 1800 rpm
 Inlet Condition = 0 bar
 Oil Type = ISO VG46
 Oil Temperature = 50°C
 Compressed oil volume = 5 litres

Note:

The response values shown in the table above are typical of those experienced in the laboratory. Actual response time will vary with different hydraulic circuits.

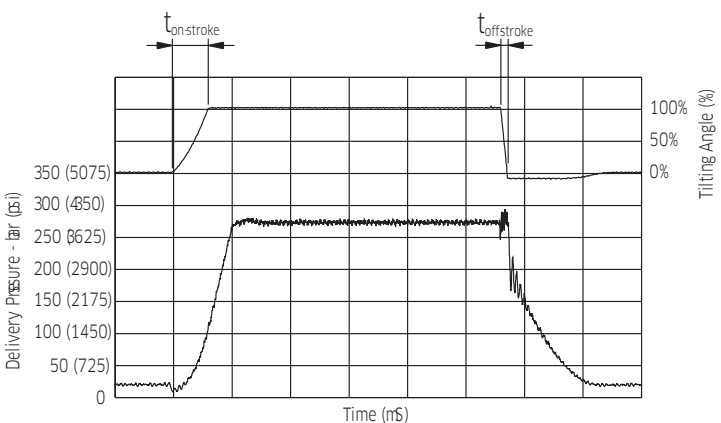
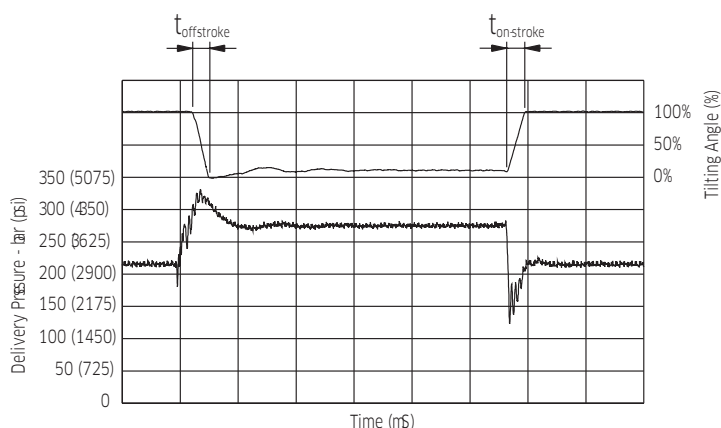
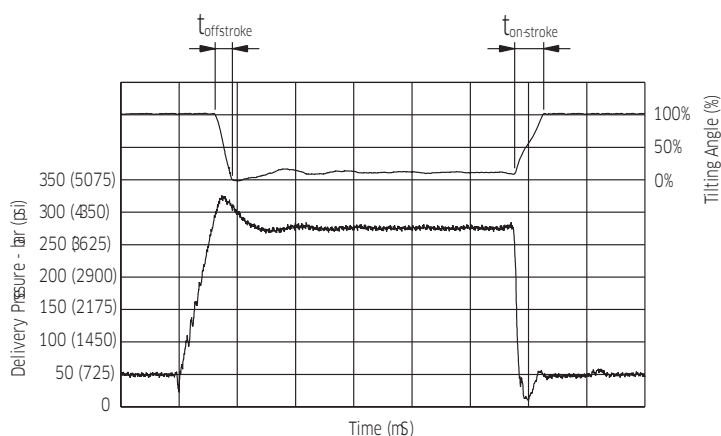

2-7 Installation (cont)

Electrical and Pilot Operated Displacement Control (Type E0, E1, E2, E3 & Q0)

Type E0 - In order for the electronic displacement control to function, a pilot pressure of 40 bar must be supplied to the Pi port on the regulator. A gear pump attached to the rear of the K3VL pump or an external pressure source can be used to provide the required pilot pressure.

Type Q0 - In order for the Q0 displacement control to function, a variable pilot pressure between 0 and 40 bar is required to be supplied to the Pi port on the regulator.

Proportional Pressure Reducing Valve Specification

Maximum Pilot Pressure : 50 bar (if higher pressure
required contact KPM UK)

Max Flow: : 10 l/min

Hydraulic oil : Mineral oil

Oil temp range : -20~+90°C

Viscosity range : 5~500 cSt

Electrical Specifications

	E0, E1, E2 24V DC	E3 12V DC
Rated Current	700 mA	1,400 mA
Recommended Dither	80 Hz/200 mAp-p	80 Hz/200 mAp-p
Coil Resistance	17.5 Ω	3.2 Ω
Ambient Temperature Range	-30 ~+95°C	-30 ~+95°C
Water Resistance	According to JIS D 0203 S2 SAE J575	According to JIS D 0203 S2 SAE J575
IP Rating	IPX6	IPX6

3 Dimensions

3-1 K3VL28 Installation

◆ K3VL28 with Cut-Off / Load Sense Control (Clockwise Rotation)

Inlet and outlet ports reversed for counter clockwise rotation.

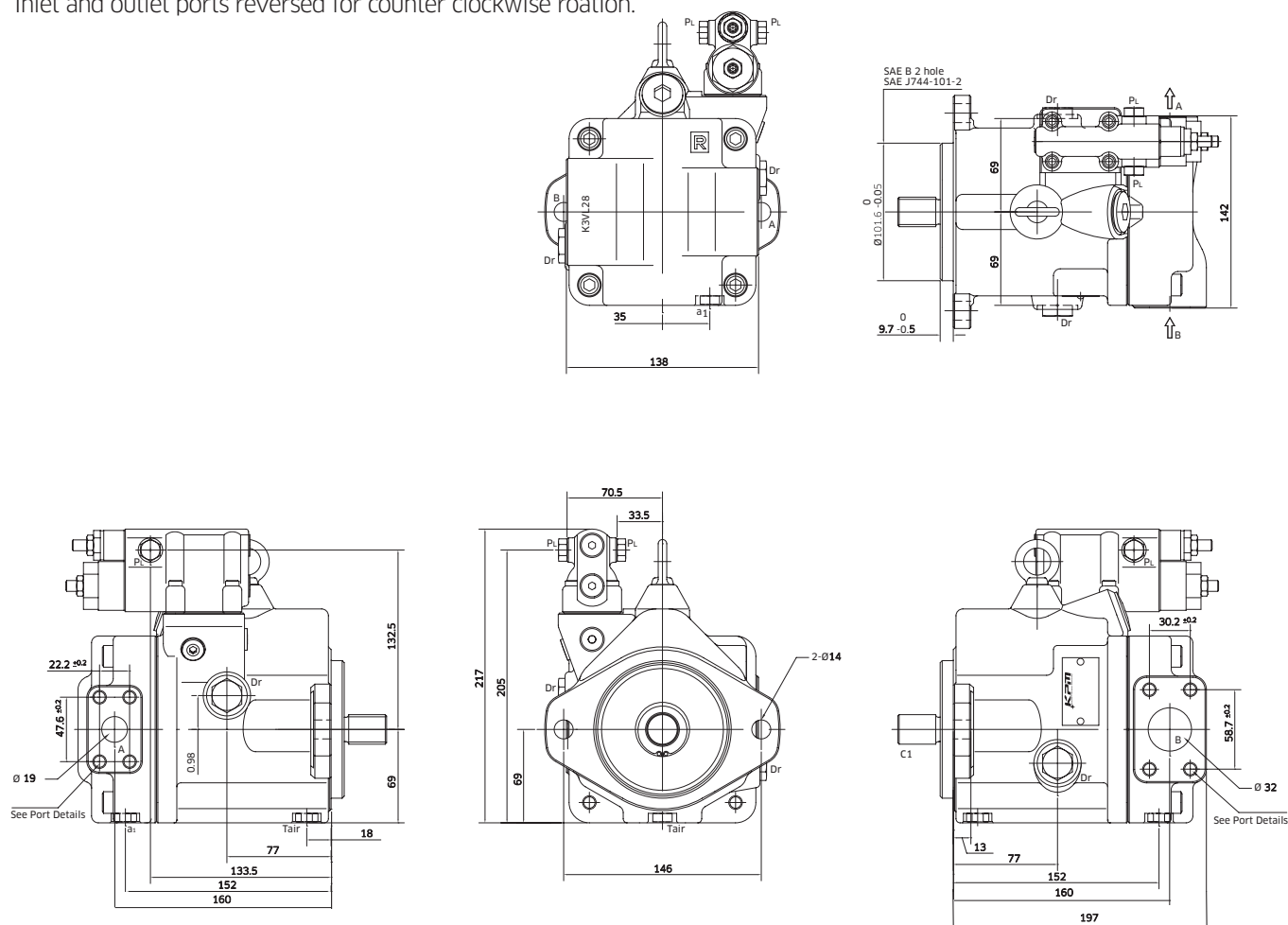

Port Details

Des.	Port Name	Port Size and Description	Tightening Torque (Nm)
A	Delivery Port	$\frac{3}{4}$ SAE J518C Code 61 (5,000 psi) Unified Thread Type 'S' $\frac{3}{8}$ -16-2B(0.66")	57
B	Inlet Port	$1\frac{1}{4}$ SAE J518 Code 61 (3,000 psi) Unified Thread Type 'S' $\frac{7}{16}$ -16-2B(0.66")	57
Dr	Drain Port	$\frac{1}{2}$ O-Ring Boss -8 SAE J1926/1 ($\frac{3}{4}$ "-16 UNF-2B)	98
P	PO/LO Control Port	$\frac{1}{4}$ O-Ring Boss -4 SAE J1926/1 ($\frac{7}{16}$ "-20 UNF-2B)	12
T	Air Bleed Port	$\frac{1}{4}$ O-Ring Boss -4 SAE J1926/1 ($\frac{7}{16}$ "-20 UNF-2B)	12
a	Gauge Port	$\frac{1}{4}$ O-Ring Boss -4 SAE J1926/1 ($\frac{7}{16}$ "-20 UNF-2B)	12

3-1 K3VL28 Installation (cont)

◆ K3VL28 Shaft & Through Drive Options

Model Code Option 'K' Shaft

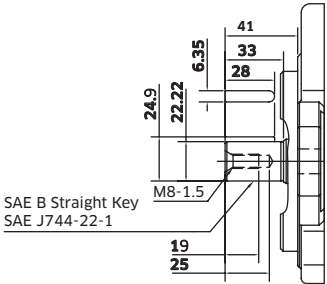

Model Code Option 'S' Shaft

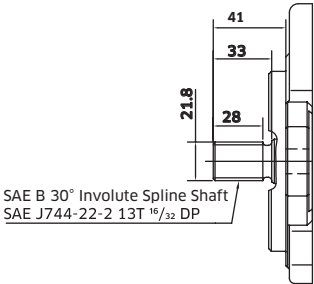

Through Drive SAE 'A'

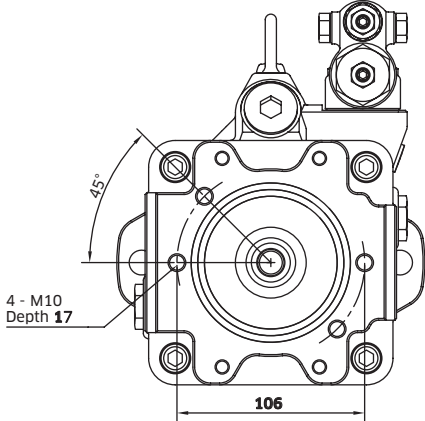
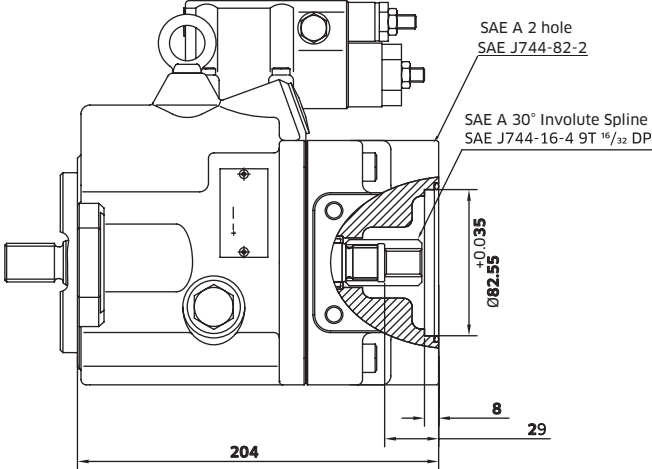

Through Drive SAE 'B'

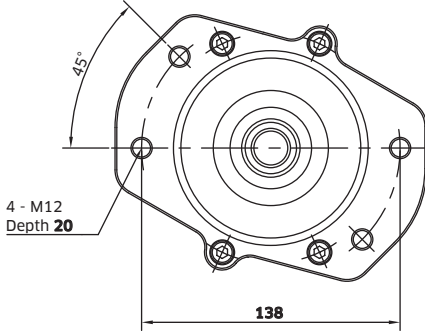
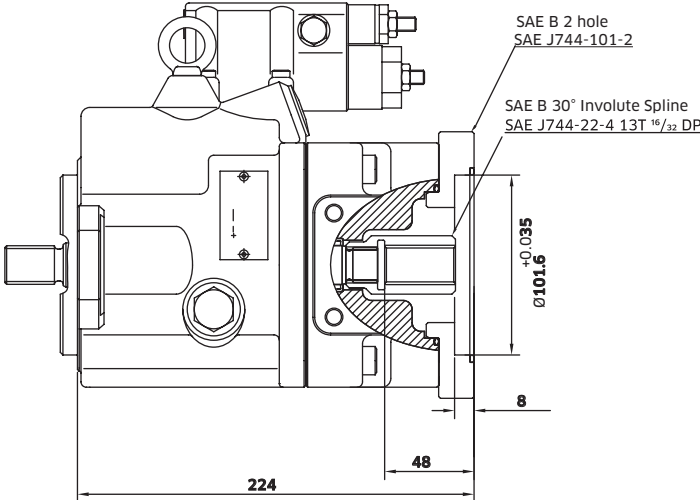

3-1 K3VL28 Installation (cont)

◆ K3VL28 Adaptor Kits

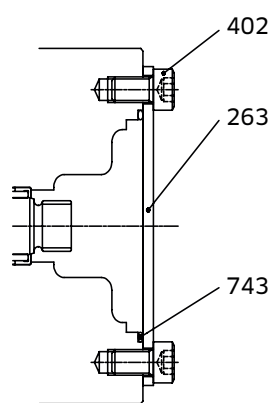

Cover Kit

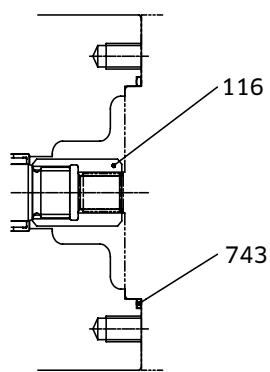

SAE 'A' T/D Kit

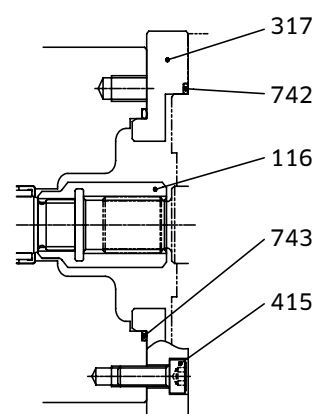

SAE "B" T/D KIT

Part Name	Qty	Cover Kit	SAE 'A' T/D Kit	SAE 'B' T/D Kit
T/D	-	29L8TN	29L3TA	29L3TB
O-Ring	1	Item 743	Item 743	Item 743
O-Ring	1	-	-	Item 742
Screw Hex SHC	4	-	-	Item 415
Screw Hex SHC	2	Item 402	-	-
Subplate	1	-	-	Item 317
Cover	1	Item 263	-	-
Coupling	1	-	Item 116	Item 116

3-2 K3VL45/60 Installation

◆ K3VL45/60 with Cut-Off / Load Sense Control & Torque Limit Module (Clockwise Rotation)

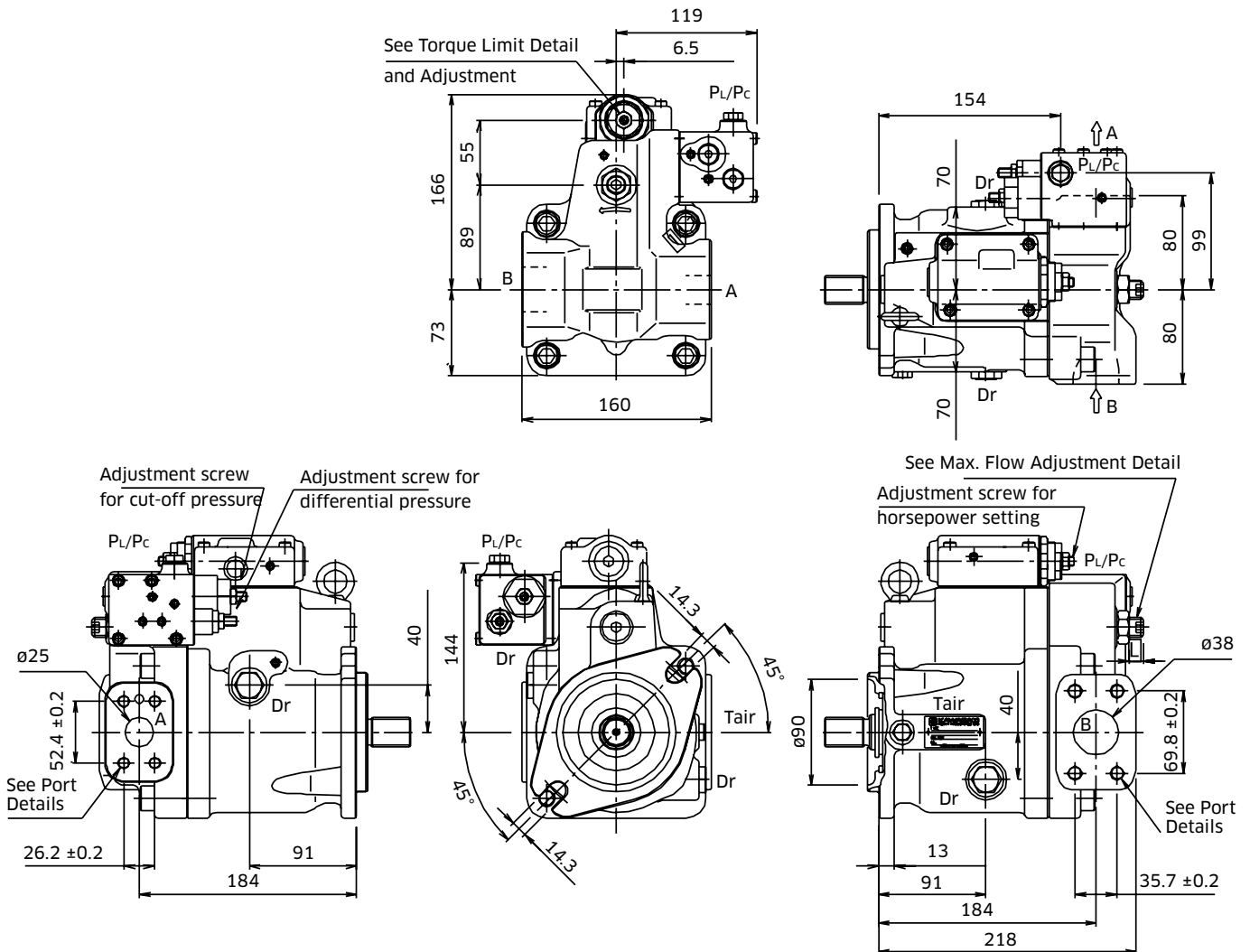

Note: for counter clockwise rotation, the inlet port 'B' and the delivery port 'A' are reversed.

3-2 K3VL45/60 Installation (cont)

◆ K3VL45/60 Mounting Flange and Shaft Options

SAE Type

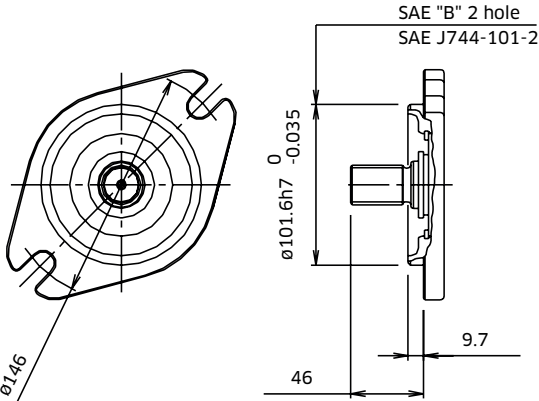

ISO Type

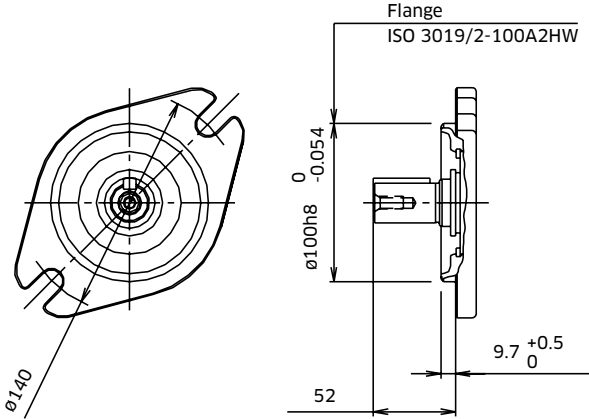

SAE 'BB' Spline Shaft - Option 'S'

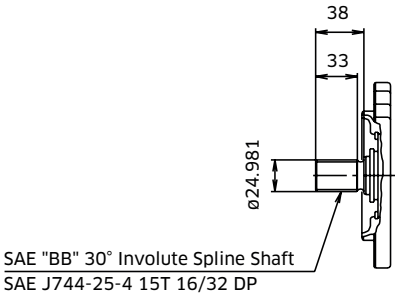

SAE 'BB' Straight Shaft - Option 'K'

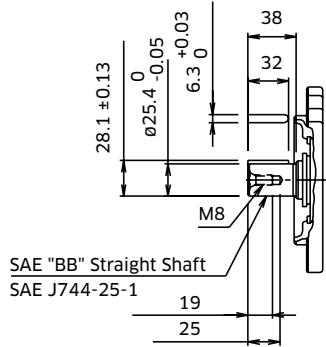

SAE 'B' Spline Shaft - Option 'T'

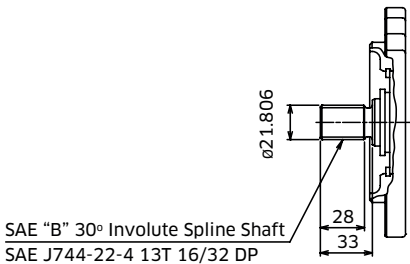

ISO Straight Shaft - Option 'M'

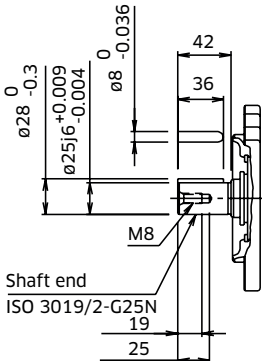

3-2 K3VL45/60 Installation (cont)

◆ K3VL45/60 Rear Port

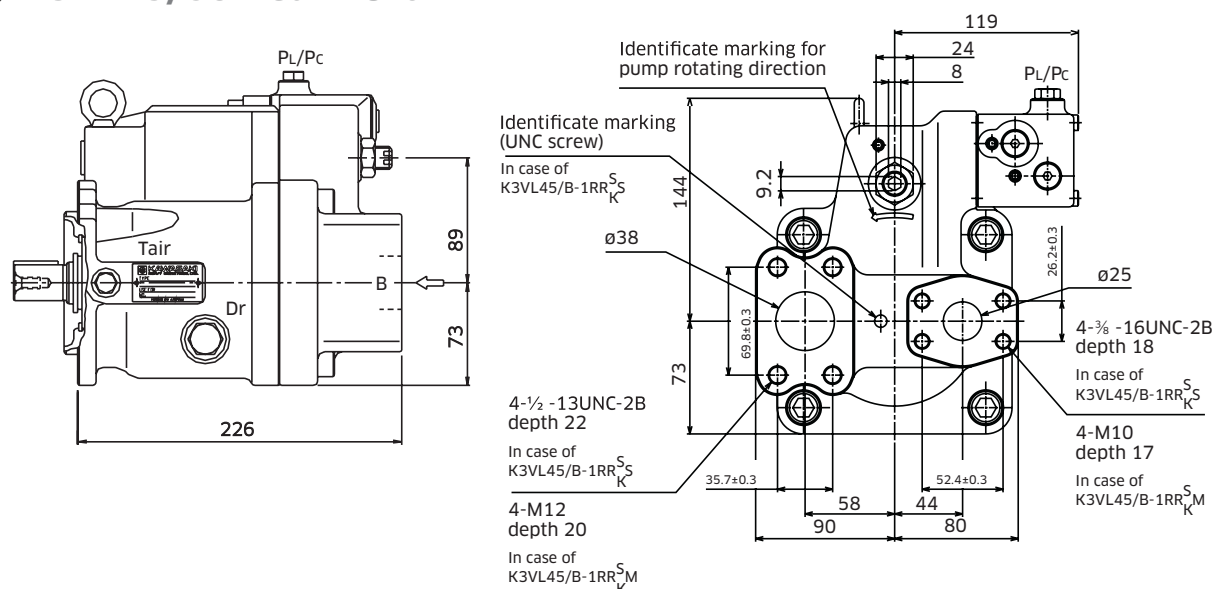

◆ K3VL45/60 Porting Details

Main SAE Flanged Ports

Des.	Port Name	Port Size	Tightening Torque (Nm)	Flange Threads
------	-----------	-----------	------------------------	----------------

UNF Threaded Version ('S' in position 9 of model code)

A	Delivery Port	SAE J518C Std pressure (code 61) 1"	57	3/8-16UNC-2B x 18 mm
B	Suction Port	SAE J518C Std pressure (code 61) 1.5"	98	1/2-13UNC-2B x 22 mm

Metric Version ('M' in position 9 of model code)

A	Delivery Port	SAE J518C Std pressure (code 61) 1"	57	M10 x 17
B	Suction Port	SAE J518C Std pressure (code 61) 1.5"	98	M12 x 20

Auxillary Ports

Des.	Port Name	Port Size	Tightening Torque (Nm)
------	-----------	-----------	------------------------

SAE Version ('S', 'K', or 'T' in position 8 of model)

Dr	Drain Port (x2)	SAE J1926/1 Straight thread O ring boss 1/2" OD Tube 3/4-16UNF-2B	98
P _L /P _C	Load Sensing Port Pressure Control Port	SAE J1926/1 Straight thread O ring boss 1/4" OD Tube 7/16-20UNF-2B	12
T _{air}	Air Bleeder Port	SAE J1926/1 Straight thread O ring boss 1/4" OD Tube 7/16-20UNF-2B	12

ISO Version ('M' in position 8 of model code)

Dr	Drain Port (x2)	M22 x 1.5 DIN 3852	98
P _L /P _C	Load Sensing Port Pressure Control Port	M14 x 1.5 DIN 3852	25
T _{air}	Air Bleeder Port	M14 x 1.5 DIN 3852	25

3-2 K3VL45/60 Installation (cont)

◆ K3VL45/60 Through Drive Options

Through Drive 'A'

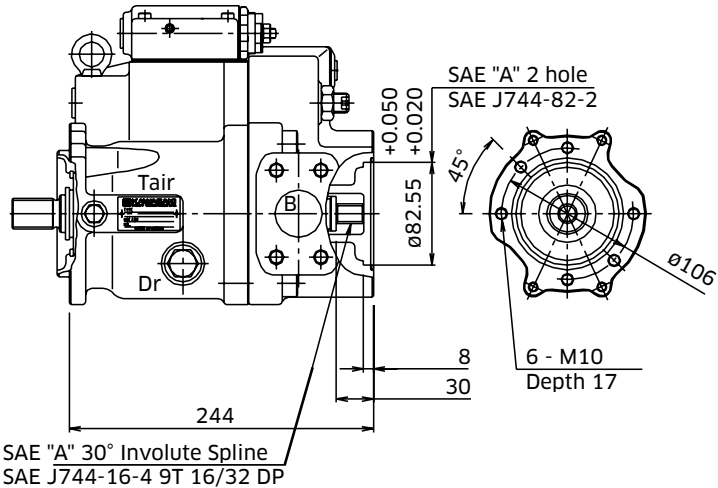

Through Drive 'B'

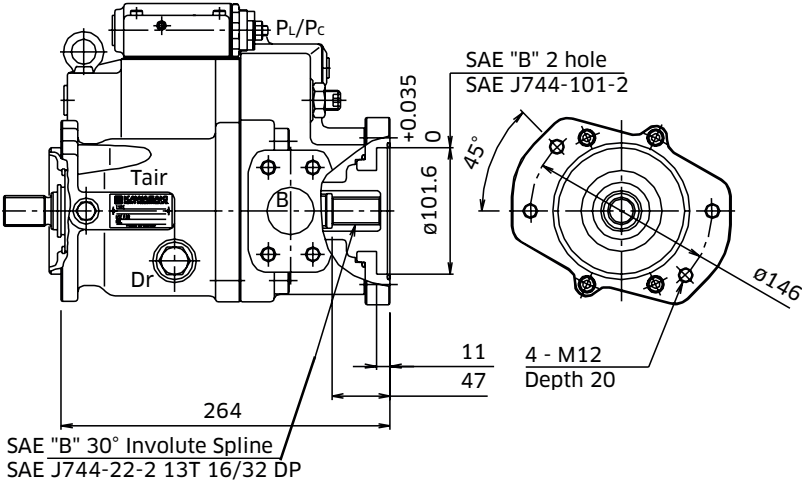

Through Drive 'BB'

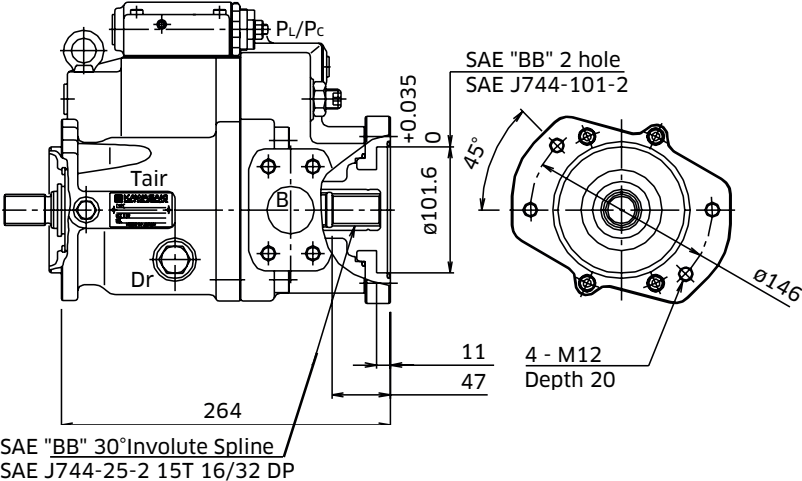

3-2 K3VL45/60 Installation (cont)

◆ K3VL45/60 Adaptor Kits

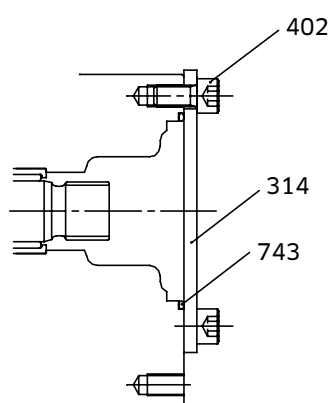

COVER KIT

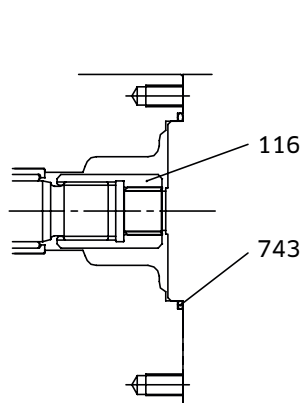

SAE 'A' T/D KIT

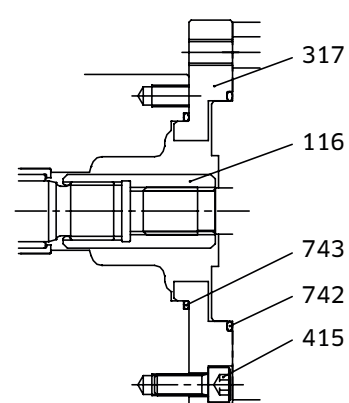

SAE 'B' & 'BB' T/D KIT

Part Name	Qty	Cover Kit	SAE 'A' T/D Kit	SAE 'B' T/D Kit	SAE 'BB' T/D Kit
T/D	-	29L8TN	29L4TA	29L4TB	29L4T2
O-Ring	1	Item 743	Item 743	Item 743	Item 743
O-Ring	1	-	-	Item 742	Item 742
Screw Hex SHC	4	-	-	Item 415	Item 415
Screw Hex SHC	2	Item 402	-	-	-
Subplate	1	-	-	Item 317	Item 317
Cover	1	Item 314	-	-	-
Coupling	1	-	Item 116	Item 116	Item 116

3-3 K3VL80 Installation

◆ K3VL80 with Cut-Off / Load Sense Control & Torque Limit Module (Clockwise Rotation)

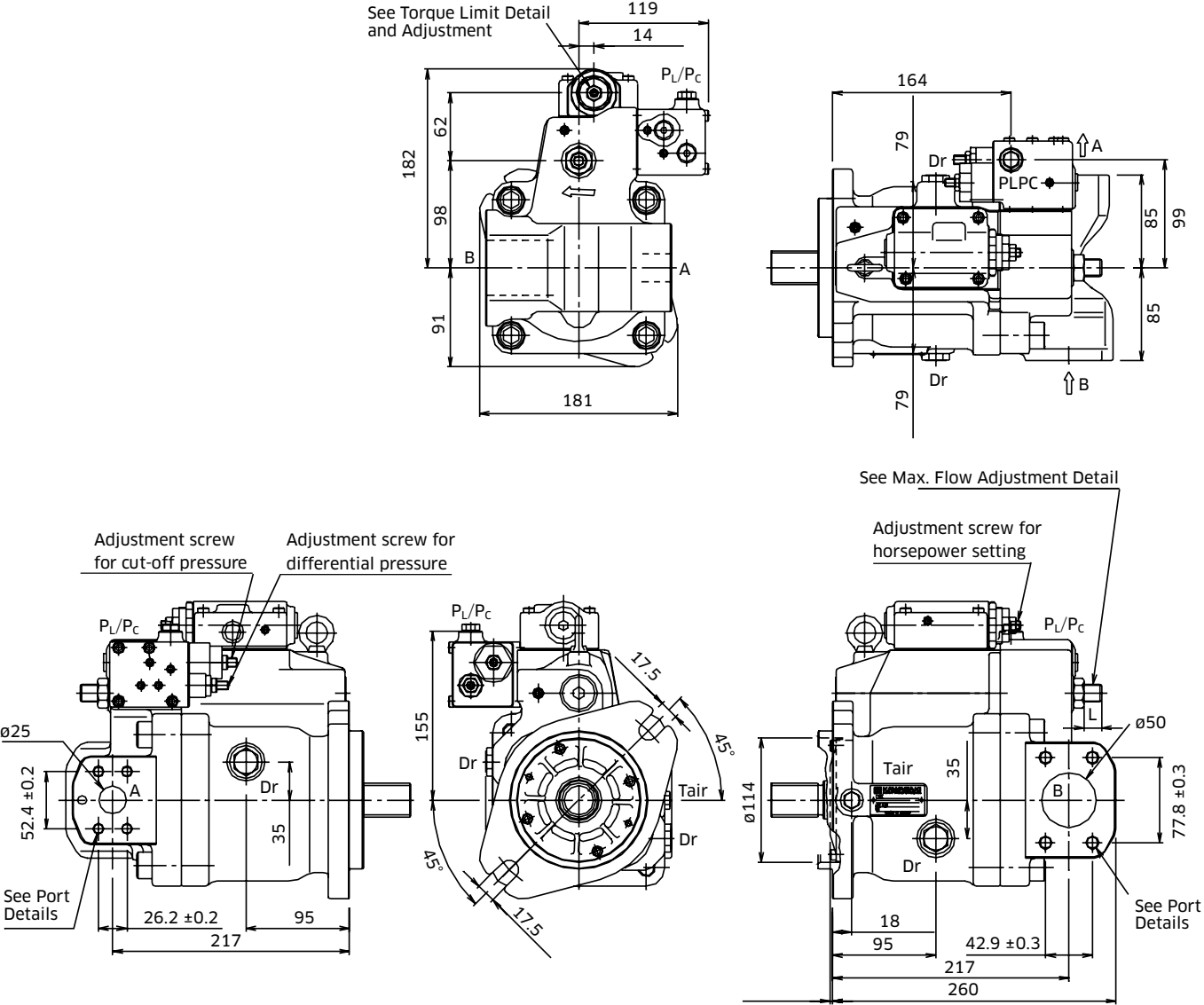

Note: for counter clockwise rotation, the suction port 'B' and the delivery port 'A' are reversed.

3-3 K3VL80 Installation (cont)

◆ K3VL80 Mounting Flange and Shaft Options

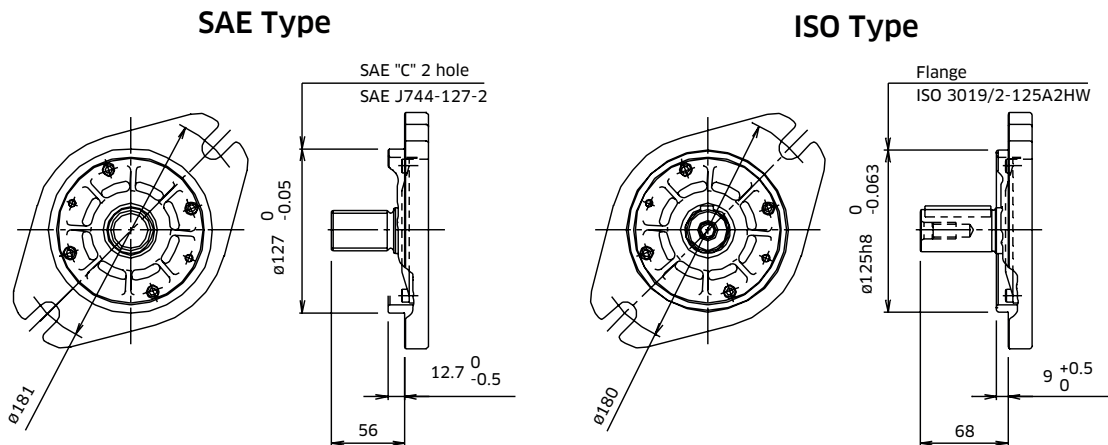

SAE 'C' Spline Shaft - Option 'S'

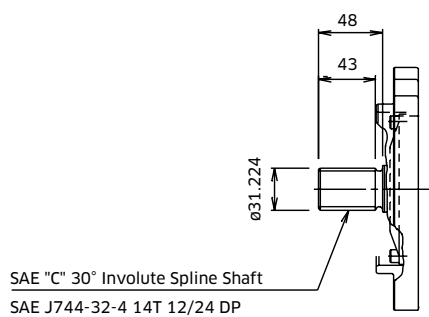

SAE 'C' Straight Shaft - Option 'K'

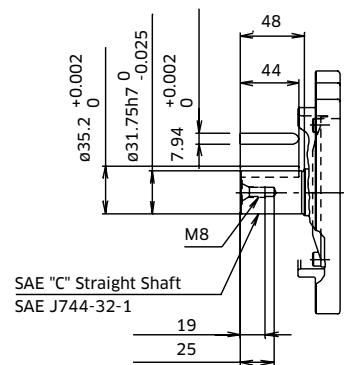

ISO Straight Shaft - Option 'M'

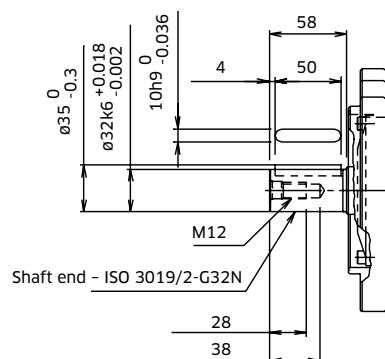

3-3 K3VL80 Installation (cont)

◆ K3VL80 Rear Port

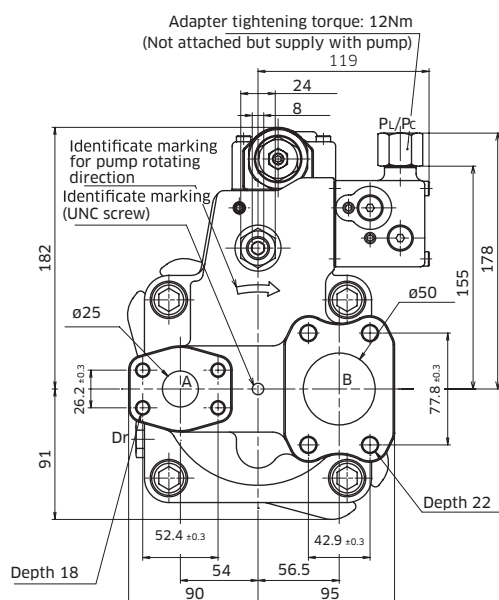
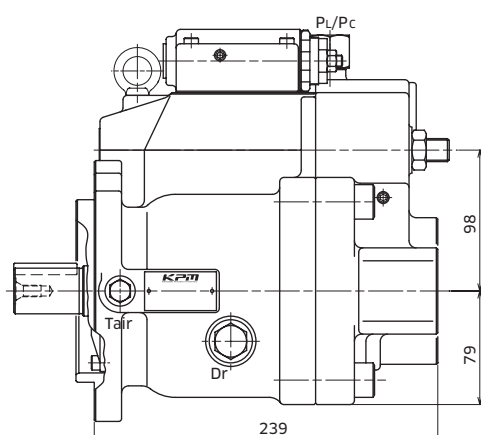

◆ K3VL80 Porting Details

Main SAE Flanged Ports

Des.	Port Name	Port Size	Tightening Torque (Nm)	Flange Threads
------	-----------	-----------	------------------------	----------------

UNF Threaded Version ('S' in position 9 of model code)

A	Delivery Port	SAE J518C Std pressure (code 61) 1"	57	3/8"-16UNC-2B x 18 mm
B	Suction Port	SAE J518C Std pressure (code 61) 2"	98	1/2"-13UNC-2B x 22 mm

Metric Version ('M' in position 9 of model code)

A	Delivery Port	SAE J518C Std pressure (code 61) 1"	57	M10 x 17
B	Suction Port	SAE J518C Std pressure (code 61) 2"	98	M12 x 20

Auxillary Ports

Des.	Port Name	Port Size	Tightening Torque (Nm)
------	-----------	-----------	------------------------

SAE Version ('S', 'K', or 'T' in position 8 of model)

Dr	Drain Port (x2)	SAE J1926/1 Straight thread O ring boss 1/2" OD Tube 3/4"-16UNF-2B	98
P _L /P _C	Load Sensing Port Pressure Control Port	SAE J1926/1 Straight thread O ring boss 1/4" OD Tube 7/16"-20UNF-2B	12
T _{air}	Air Bleeder Port	SAE J1926/1 Straight thread O ring boss 1/4" OD Tube 7/16"-20UNF-2B	12

ISO Version ('M' in position 8 of model code)

Dr	Drain Port (x2)	M22 x 1.5 DIN 3852	98
P _L /P _C	Load Sensing Port Pressure Control Port	M14 x 1.5 DIN 3852	25
T _{air}	Air Bleeder Port	M14 x 1.5 DIN 3852	25

3-3 K3VL80 Installation (cont)

◆ K3VL80 Through Drive Options

Through Drive 'A'

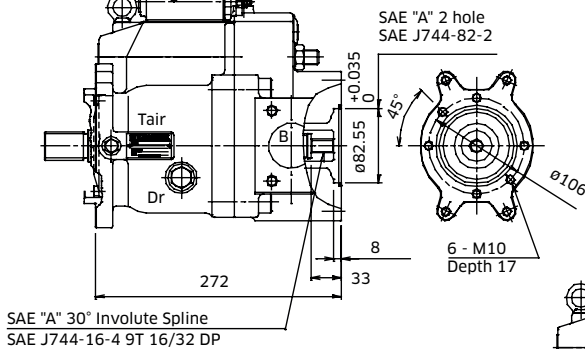

Through Drive 'B'

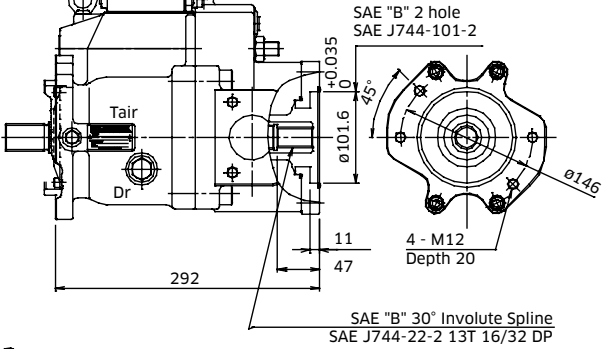

Through Drive 'BB'

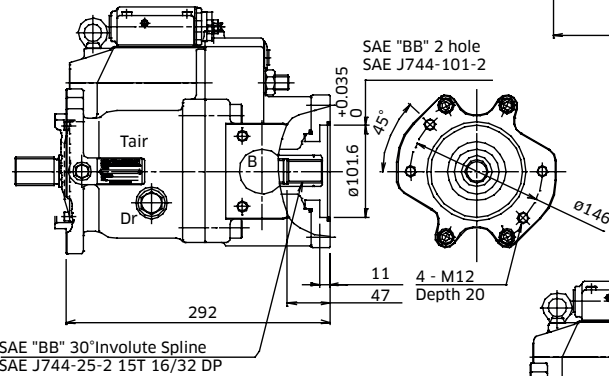

Through Drive 'C'

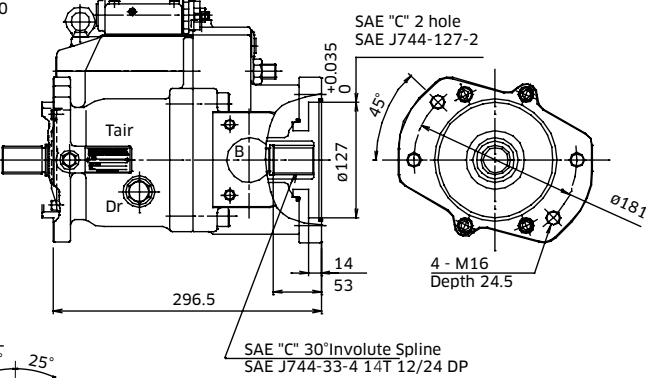

Through Drive 'C4'

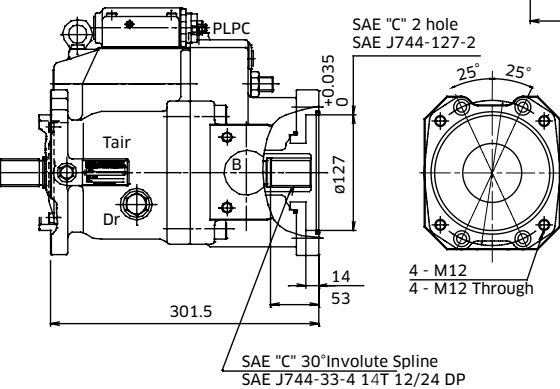

3-3 K3VL80 Installation (cont)

◆ K3VL80 Adaptor Kits

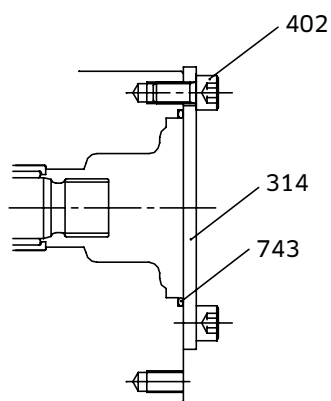

Cover Kit

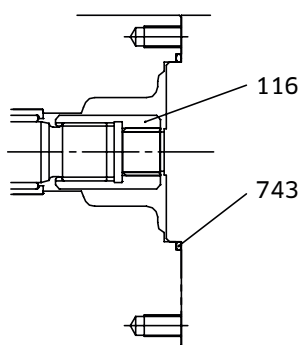

SAE 'A' T/D Kit

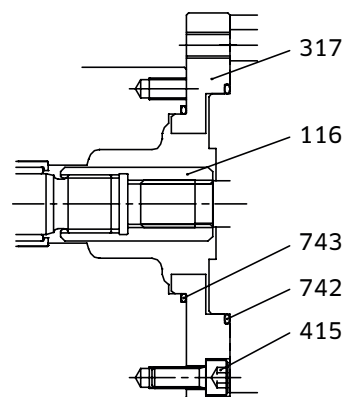

SAE 'B', 'BB', 'C' & 'C4' T/D Kit

Part Name	Qty	Cover Kit	SAE 'A' T/D Kit	SAE 'B' T/D Kit
T/D	-	29L8TN	29L8TA	29L8TB
O-Ring	1	Item 743	Item 743	Item 743
O-Ring	1	-	-	Item 742
Screw Hex SHC	4	-	-	Item 415
Screw Hex SHC	2	Item 402	-	-
Subplate	1	-	-	Item 317
Cover	1	Item 314	-	-
Coupling	1	-	Item 116	Item 116

Part Name	Qty	SAE 'BB' T/D Kit	SAE 'CC' T/D Kit	SAE 'C4' T/D Kit
T/D	-	29L8T2	29L8TC	29L8TC4
O-Ring	1	Item 743	Item 743	Item 743
O-Ring	1	Item 742	Item 742	Item 742
Screw Hex SHC	4	Item 415	Item 415	Item 415
Screw Hex SHC	2	-	-	-
Subplate	1	Item 317	Item 317	Item 317
Cover	1	-	-	-
Coupling	1	Item 116	Item 116	Item 116

3-4 K3VL112/140 Installation

◆ K3VL112/140 with Cut-Off / Load Sense Control & Torque Limit Module (Clockwise Rotation)

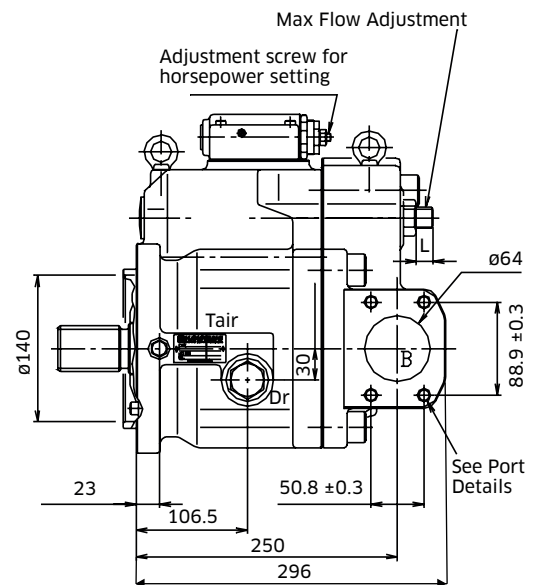
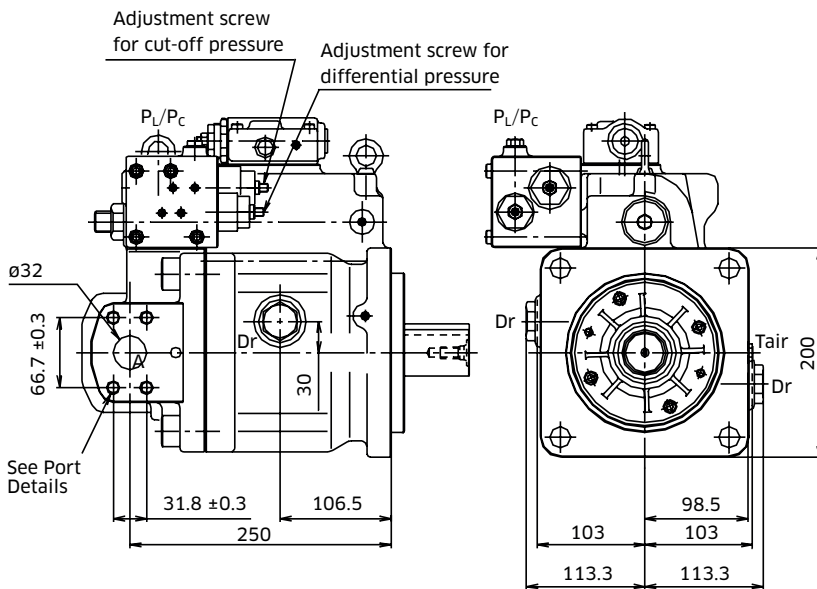
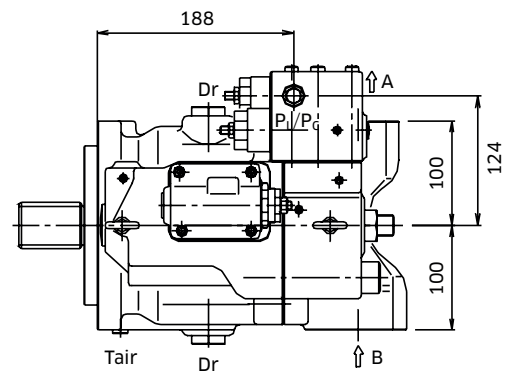
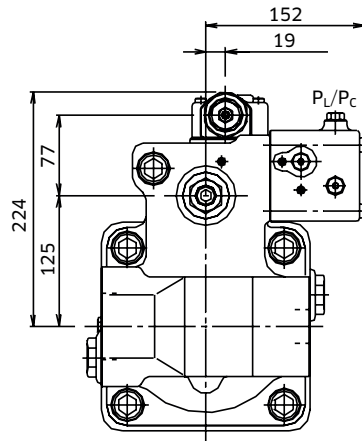

Note: for counter clockwise rotation, the suction port 'B' and the delivery port 'A' are reversed.

3-4 K3VL112/140 Installation (cont)

◆ K3VL112/140 (SAE D 4 BOLT) Mounting Flange & Shaft Options

SAE 'D' Type

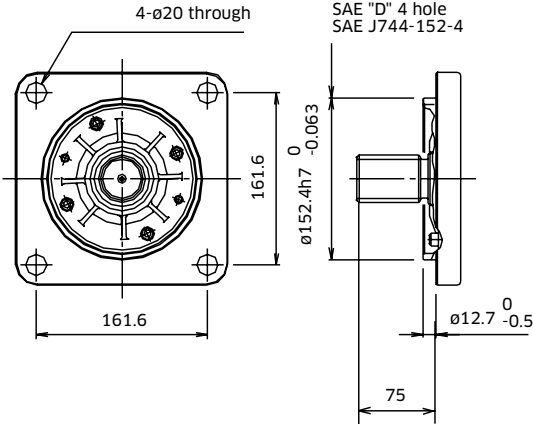

ISO Type

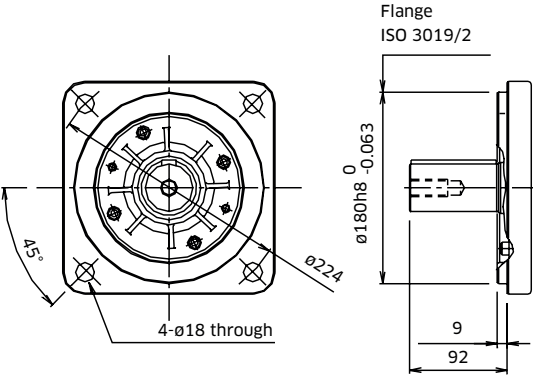

SAE 'D' Spline Shaft - Option 'S'

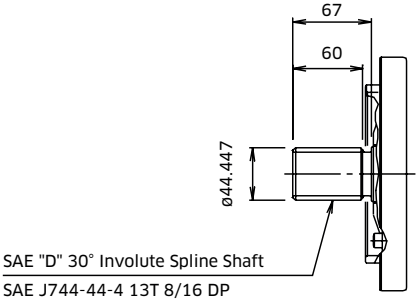

SAE 'D' Straight Shaft - Option 'K'

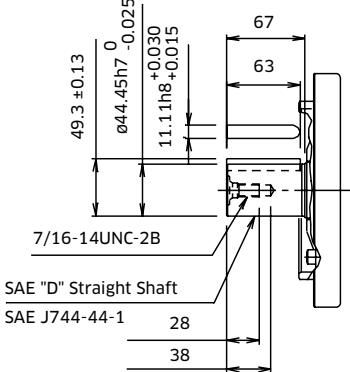

ISO Straight Shaft

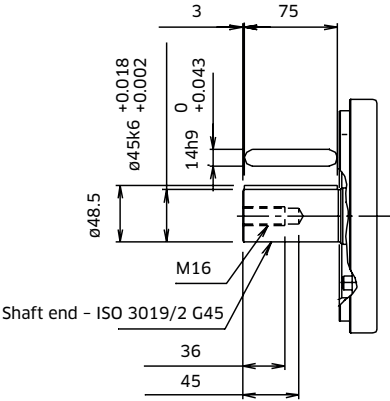

3-4 K3VL112/140 Installation (cont)

◆ K3VL112/140 Rear Port

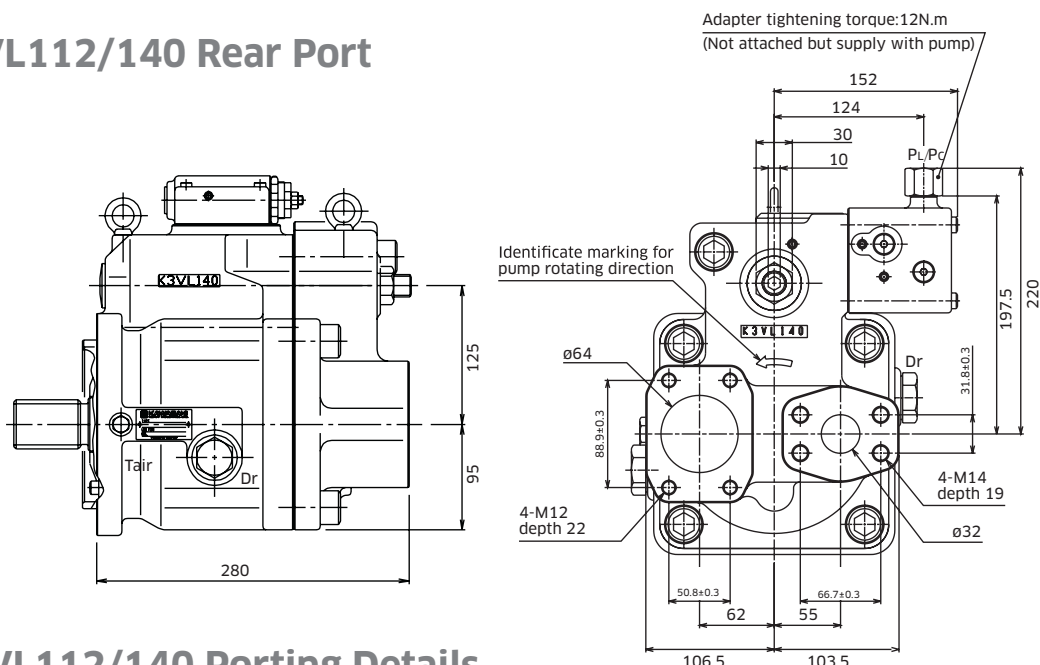

◆ K3VL112/140 Porting Details

Main SAE Flanged Ports

Des.	Port Name	Port Size	Tightening Torque (Nm)	Flange Threads
------	-----------	-----------	------------------------	----------------

UNF Threaded Version ('S' in position 9 of model code)

A	Delivery Port	SAE J518C high pressure (code 21) 1¼"	157	½-13UNC-2B x 22 mm
B	Suction Port	SAE J518C Std pressure (code 61) 2½"	98	½-13UNC-2B x 22 mm

Metric Version ('M' in position 9 of model code)

A	Delivery Port	SAE J518C high pressure (code 62) 1¼"	157	M14 x 19 *
B	Suction Port	SAE J518C Std pressure (code 61) 2½"	98	M12 x 17

* Note: ISO 6162 quotes M12

Auxiliary Ports

Des.	Port Name	Port Size	Tightening Torque (Nm)
------	-----------	-----------	------------------------

SAE Version ('S', 'K', 'C', 'R', 'U', 'X' or 'T' in position 8 of model)

Dr	Drain Port (x2)	SAE J1926/1 Straight thread O ring boss ¾" OD Tube 1 ¹ / ₁₆ -12UN-2B	167
P _L /P _C	Load Sensing Port Pressure Control Port	SAE J1926/1 Straight thread O ring boss ¼" OD Tube 7 ⁷ / ₁₆ -20UNF-2B	12
T _{air} *	Air Bleeder Port	SAE J1926/1 Straight thread O ring boss ¼" OD Tube 7 ⁷ / ₁₆ -20UNF-2B	12

ISO Version ('M' in position 8 of model code)

Dr	Drain Port (x2)	M27 x 2 DIN 3852	167
P _L /P _C	Load Sensing Port Pressure Control Port	M14 x 1.5 DIN 3852	25
T _{air}	Air Bleeder Port	M14 x 1.5 DIN 3852	25

3-4 K3VL112/140 Installation (cont)

◆ K3VL112/140 (2 Bolt) Installation

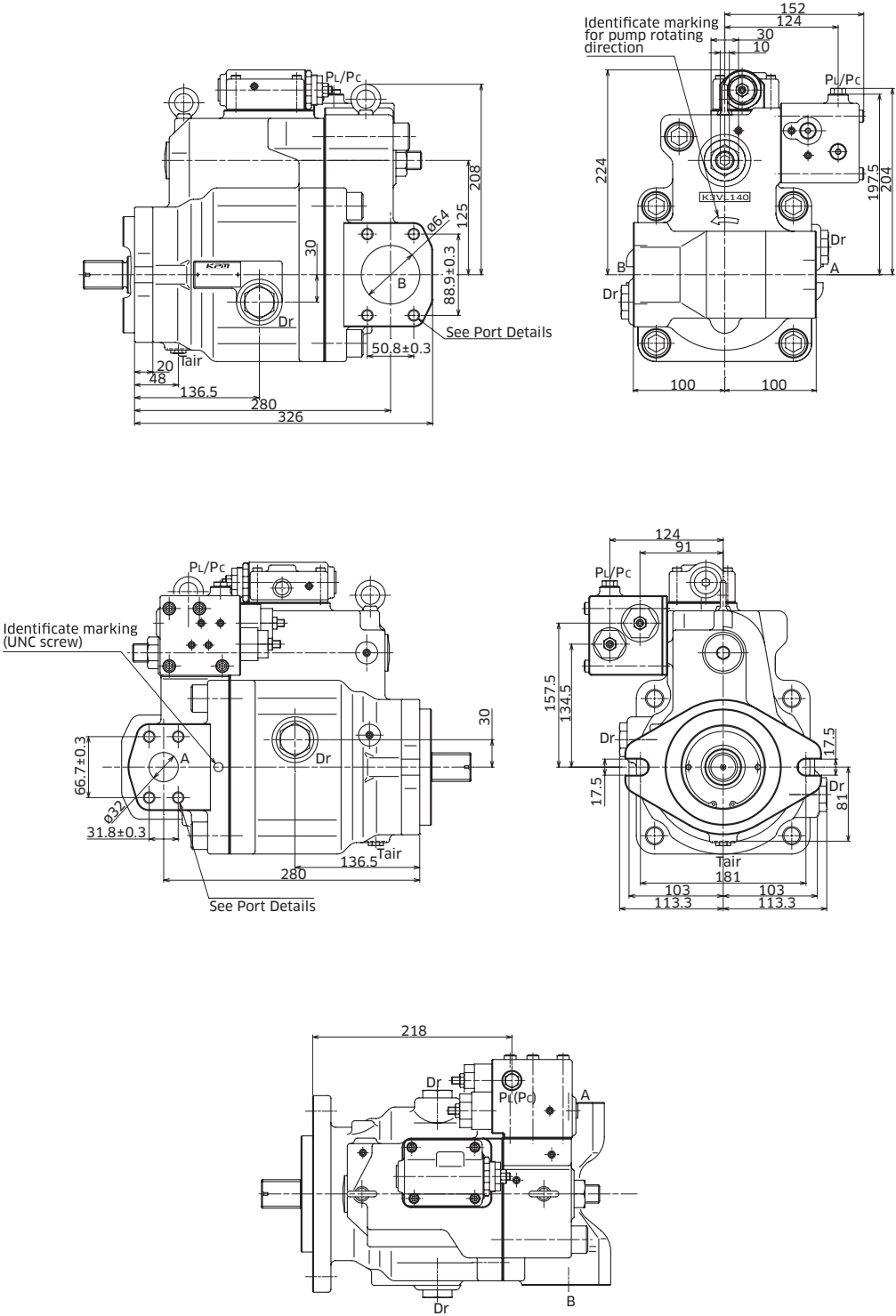

3-4 K3VL112/140 Installation (cont)

◆ K3VL112/140 Mounting Flange (2 Bolt) and Shaft Options

SAE 'C' Type

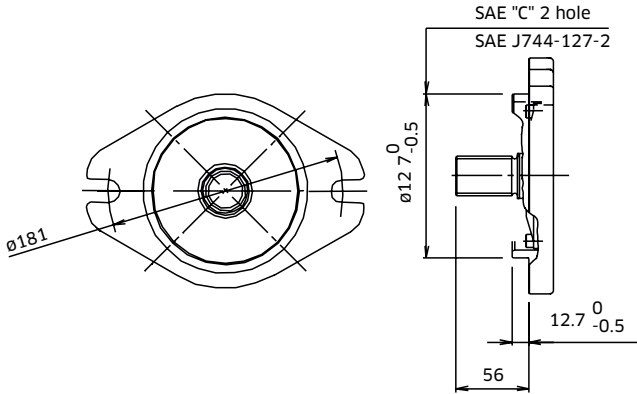

SAE 'C' Spline Shaft - Option 'C'

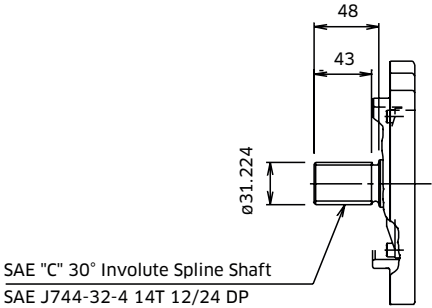

SAE 'C' Straight Shaft - Option 'X'

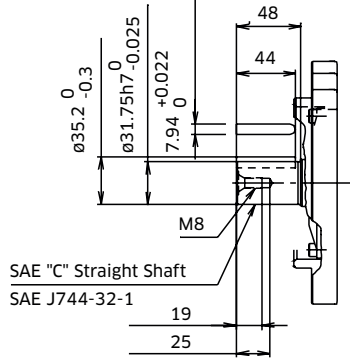

SAE 'CC' Spline Shaft - Option 'W'

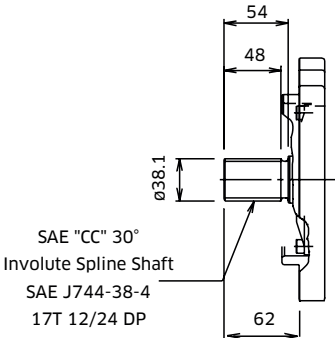

SAE 'CC' Straight Shaft - Option 'Y'

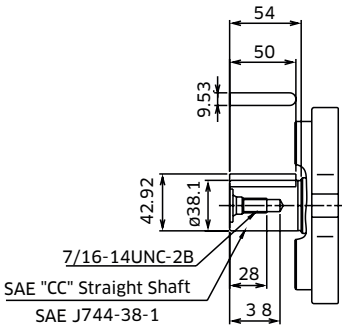

3-4 K3VL112/140 Installation (cont)

◆ K3VL112/140 Through Drive Options

Through Drive 'A'

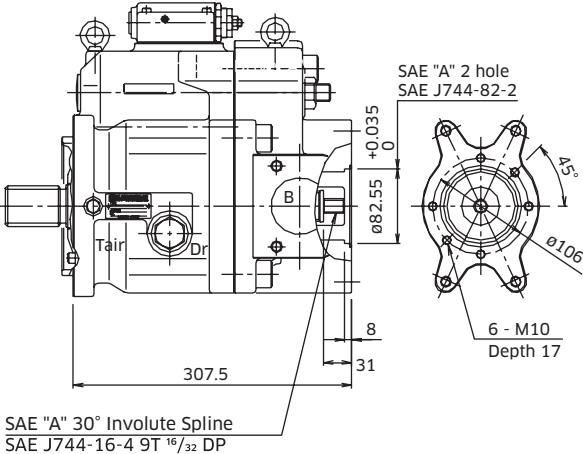

Through Drive 'B'

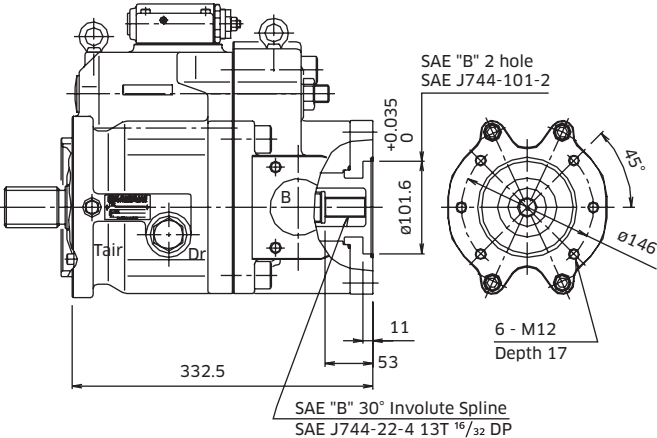

Through Drive 'BB'

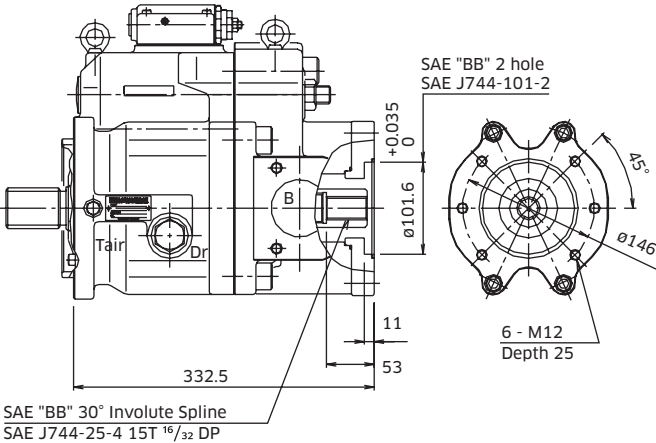

Through Drive 'C'

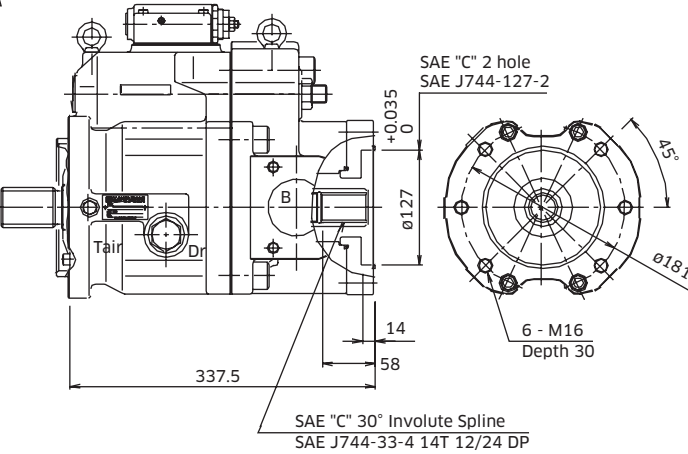

3-4 K3VL112/140 Installation (cont)

◆ K3VL112/140 Through Drive Options

Through Drive 'C4'

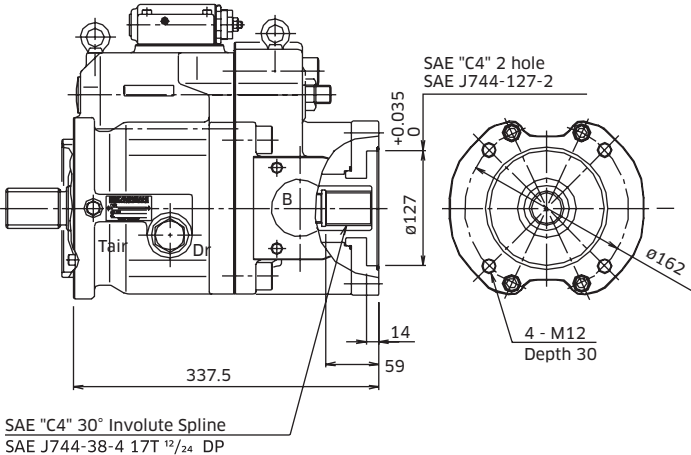

Through Drive 'CC'

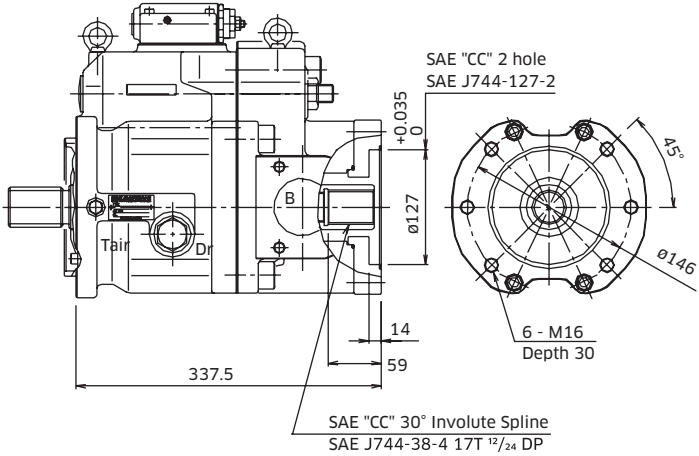

Through Drive 'D'

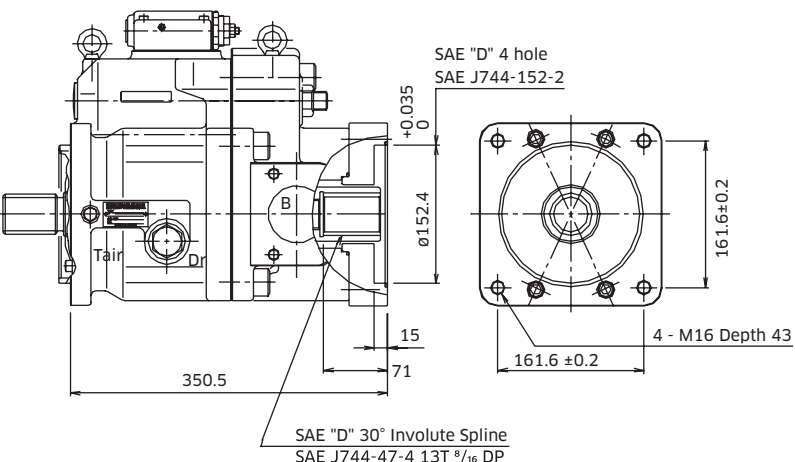

3-4 K3VL112/140 Installation (cont)

◆ K3VL112/140 Adaptor Kits

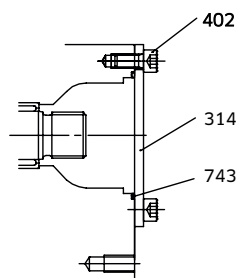

COVER KIT

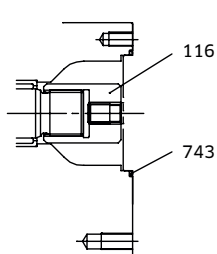

SAE 'A' T/D KIT

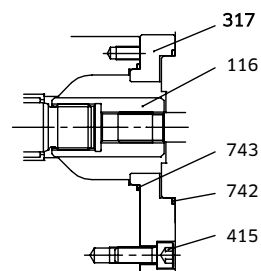

SAE 'B' T/D KIT

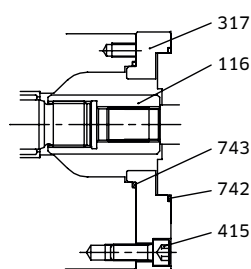

SAE 'BB' T/D KIT

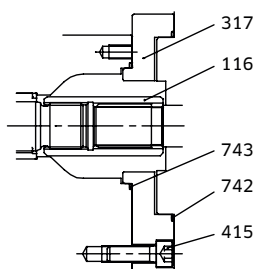

SAE 'C' & 'C4' T/D KIT

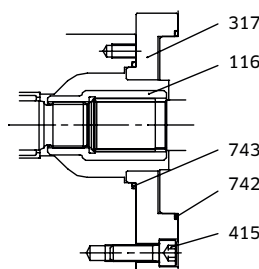

SAE 'CC' T/D KIT

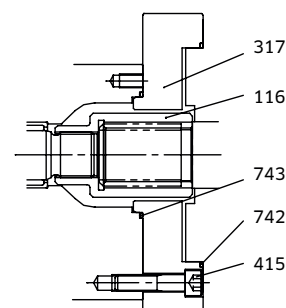

SAE 'D' T/D KIT

Part Name	Qty	Cover Kit	SAE 'A' T/D Kit	SAE 'B' T/D Kit	SAE 'BB' T/D Kit
T/D	-	29L8TN	29LHTA	29LHTB	29LHT2
O-Ring	1	Item 743	Item 743	Item 743	Item 743
O-Ring	1	-	-	Item 742	Item 742
Screw Hex SHC	4	-	-	Item 415	Item 415
Screw Hex SHC	2	Item 402	-	-	-
Subplate	1	-	-	Item 317	Item 317
Cover	1	Item 314	-	-	-
Coupling	1	-	Item 116	Item 116	Item 116

Part Name	Qty	SAE 'C' T/D Kit	SAE 'C4' T/D Kit	SAE 'CC' T/D Kit	SAE 'D' T/D Kit
T/D	-	29LHTC	29LHTC4	29LHT3	29LHTD
O-Ring	1	Item 743	Item 743	Item 743	Item 743
O-Ring	1	Item 742	Item 742	Item 742	Item 742
Screw Hex SHC	4	Item 415	Item 415	Item 415	Item 415
Screw Hex SHC	2	-	-	-	-
Subplate	1	Item 317	Item 317	Item 317	Item 317
Cover	1	-	-	-	-
Coupling	1	Item 116	Item 116	Item 116	Item 116

3-5 K3VL200 Installation

◆ K3VL200 with Cut-Off / Load Sense Control & Torque Limit Module (Clockwise Rotation)

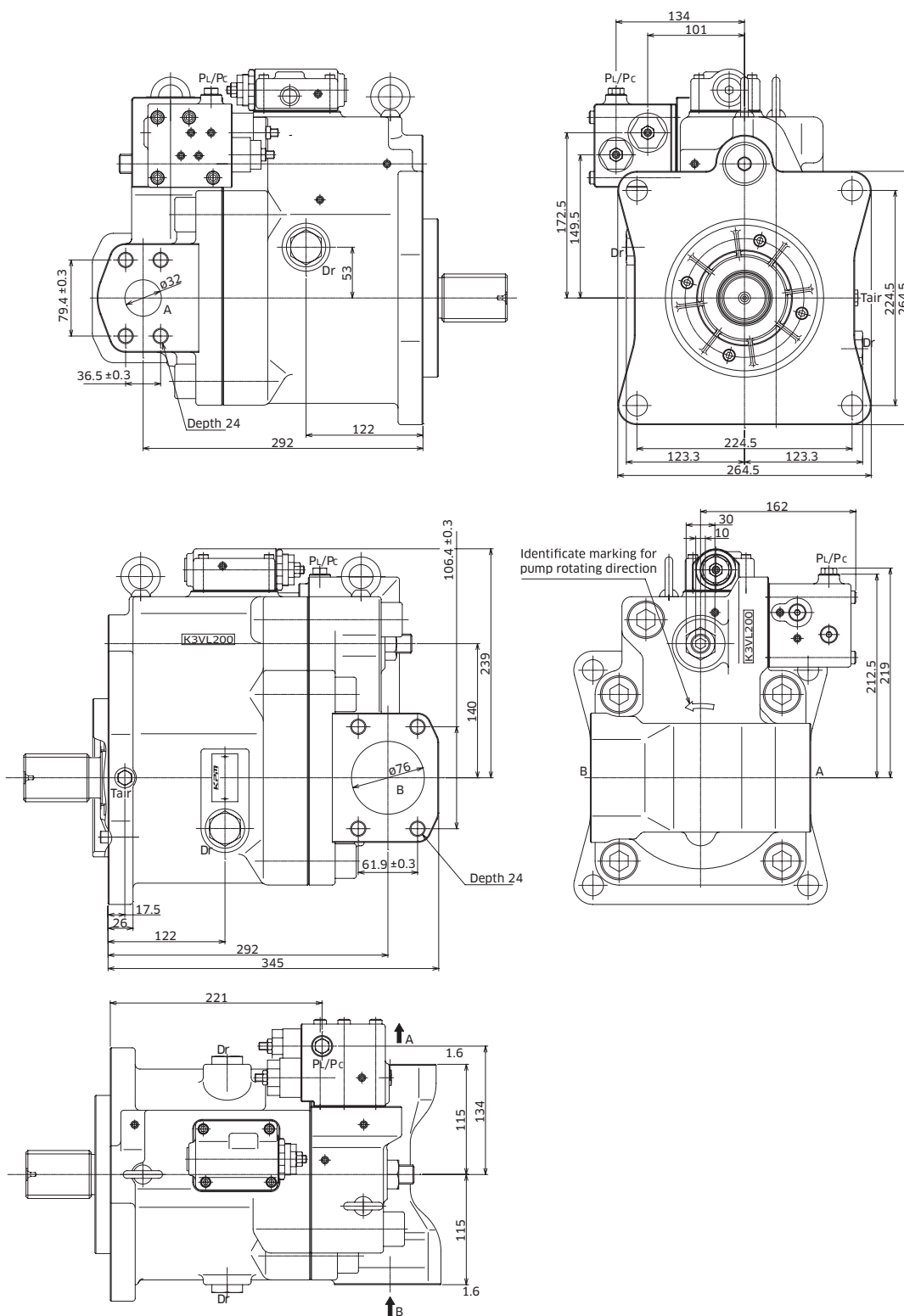

3-5 K3VL200 Installation (cont)

◆ K3VL200 Mounting Flange and Shaft Options

SAE Type

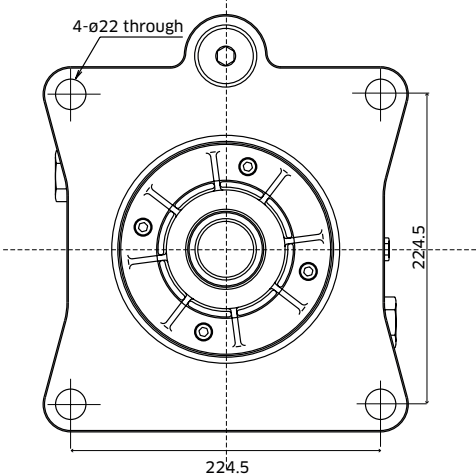

SAE Spline 'D' Shaft

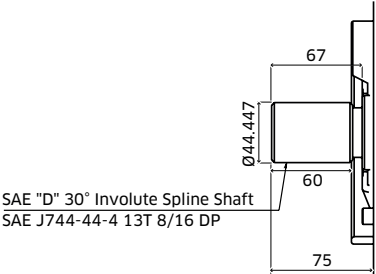

SAE 'D' Straight Shaft

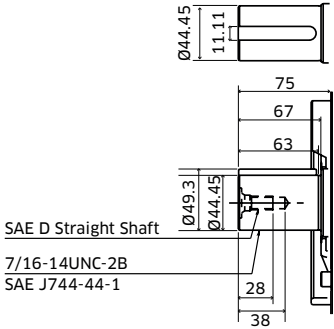

SAE Spline 'F' Shaft

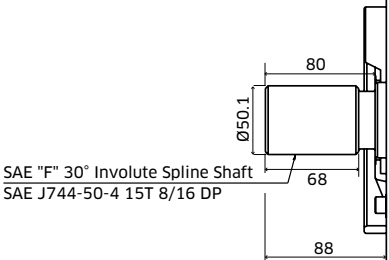

3-5 K3VL200 Installation (cont)

◆ K3VL200 Through Drive Options

Through Drive 'A'

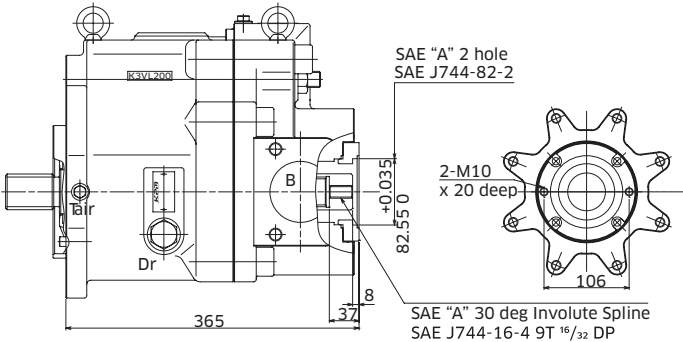

Through Drive 'B'

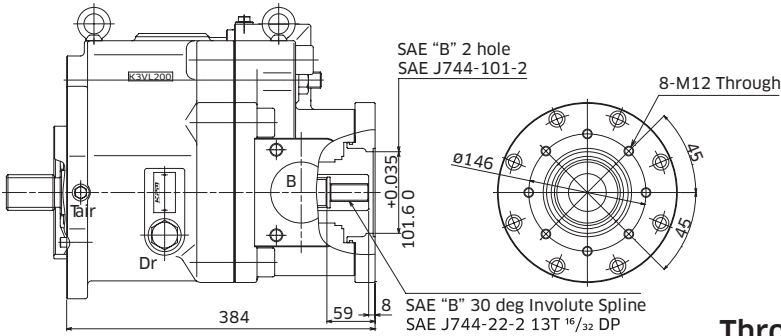

Through Drive 'BB'

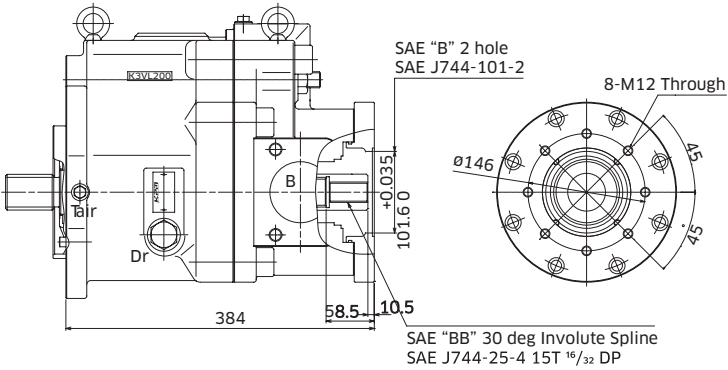

Through Drive 'C'

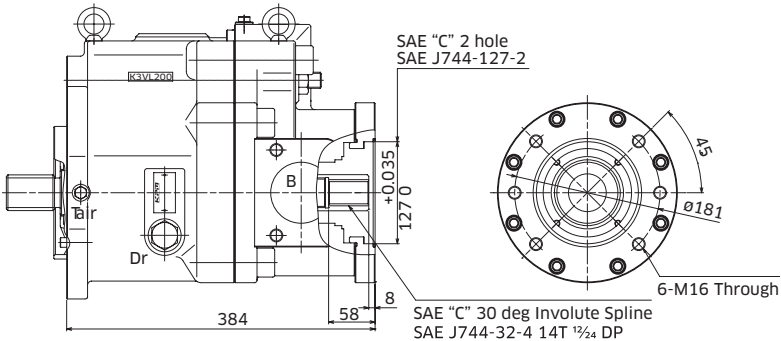

3-5 K3VL200 Installation (cont)

◆ K3VL200 Through Drive Options

Through Drive 'C4'

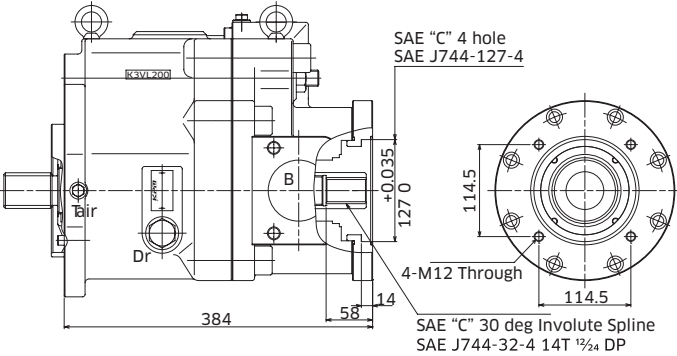

Through Drive 'CC'

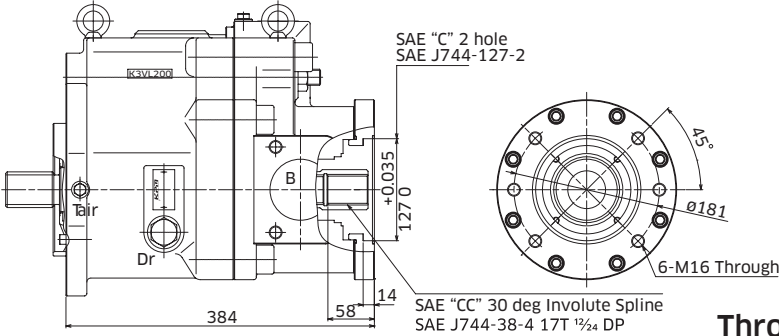

Through Drive 'D'

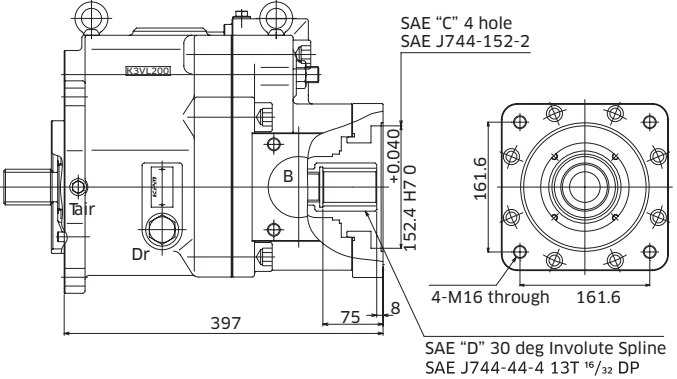

Through Drive 'E'

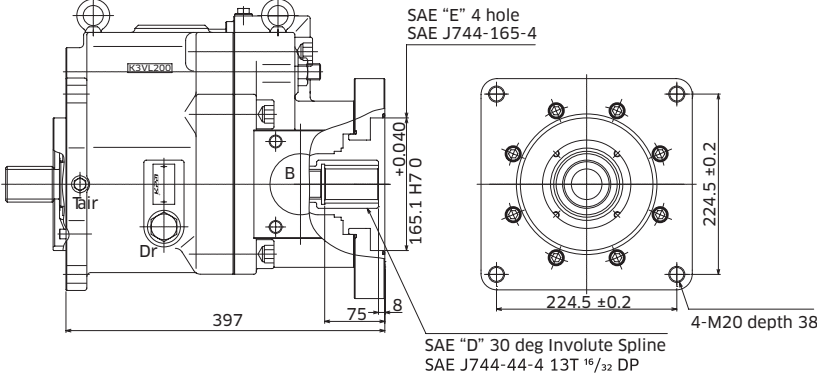

3-5 K3VL200 Installation (cont)

Main SAE Flanged Ports

Des.	Port Name	Port Size	Tightening Torque (Nm)	Flange Threads
------	-----------	-----------	------------------------	----------------

UNC Threaded Version ('S', 'K' in position 9 of model code)

A	Delivery Port	SAE J518C high pressure (code 62) 1½"	235	5/8-11UNC -2B
B	Suction Port	SAE J518C Std pressure (code 61) 3"	235	5/8-11UNC -2B

Metric Version ('M' in position 9 of model code)

A	Delivery Port	SAE J518C high pressure (code 62) 1½"	235	M16
B	Suction Port	SAE J518C Std pressure (code 61) 3"	235	M16

Auxillary Ports

Des.	Port Name	Port Size	Tightening Torque (Nm)
------	-----------	-----------	------------------------

SAE Version ('S', 'K' in position 8 of model)

Dr	Drain Port (x2)	SAE J1926/1 Straight thread O ring boss ¾" OD Tube 1 ¹ / ₁₆ -12UNF-2B	167
P _L /P _c	Load Sensing Port Pressure Control Port	SAE J1926/1 Straight thread O ring boss ¼" OD Tube 7 ⁷ / ₁₆ -20UNF-2B	12
T _{air}	Air Bleeder Port	SAE J1926/1 Straight thread O ring boss ¼" OD Tube 7 ⁷ / ₁₆ -20UNF-2B	12

3-5 K3VL200 Installation (cont)

◆ K3VL200 Through Drive Kits

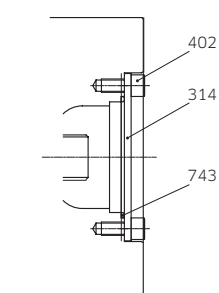

COVER Kit

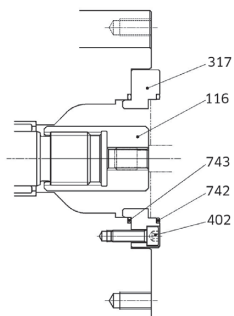

SAE "A" T/D Kit

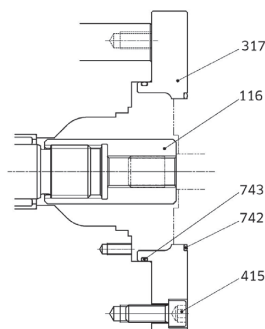

SAE "B" T/D Kit

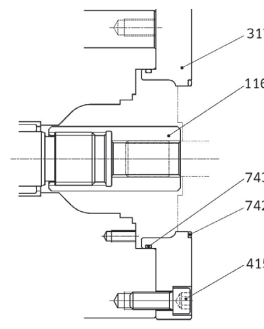

SAE "BB" T/D Kit

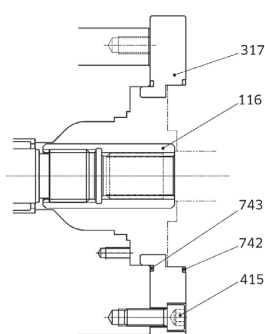

SAE "C" & "C4" T/D Kit

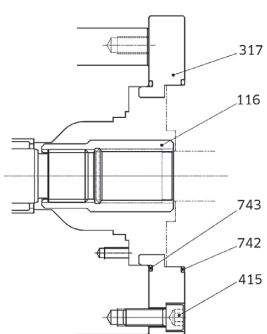

SAE "CC" T/D Kit

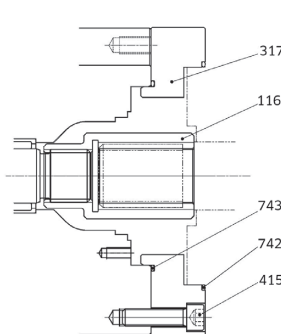

SAE "D" T/D Kit

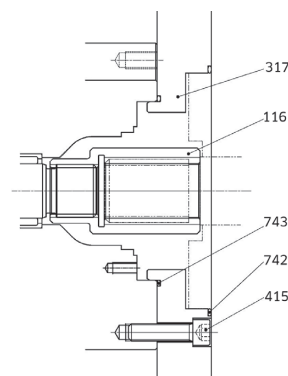

SAE "E" T/D Kit

Part Name	Qty	SAE 'A'	SAE 'B'	SAE 'BB'	SAE 'C'
T/D Kit	-	-	-	-	-
Coupling K3VL200	1	Item 116	Item 116	Item 116	Item 116
Sub Plate K3VL200	1	Item 317	Item 317	Item 317	Item 317
SHCS	8	Item 402	Item 415	Item 415	Item 415
O-Ring	1	Item 743	Item 743	Item 743	Item 743
O-Ring	1	Item 742	Item 742	Item 742	Item 742

Part Name	Qty	SAE 'C4'	SAE 'CC'	SAE 'D'	SAE 'E'
T/D Kit	-	-	-	-	-
Coupling K3VL200	1	Item 116	Item 116	Item 116	Item 116
Sub Plate K3VL200	1	Item 317	Item 317	Item 317	Item 317
SHCS	8	Item 415	Item 415	Item 415	Item 415
O-Ring	1	Item 743	Item 743	Item 743	Item 743
O-Ring	1	Item 742	Item 742	Item 742	Item 742

3-6 K3VL200H Installation (cont)

SAE 'A' Throughdrive

Please contact KPM UK for dimensions.

SAE 'B' Throughdrive

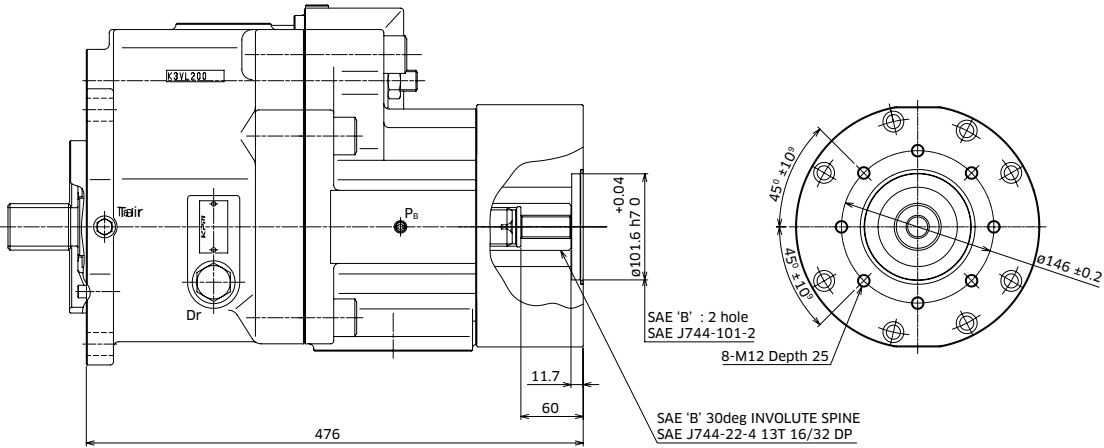

SAE 'B-B' Throughdrive

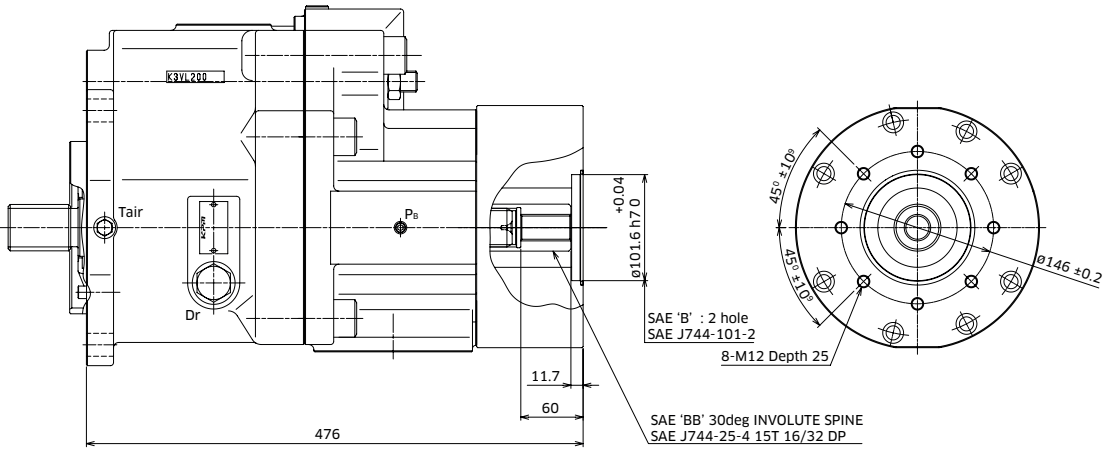

3-6 K3VL200H Installation (cont)

SAE 'C' Throughdrive

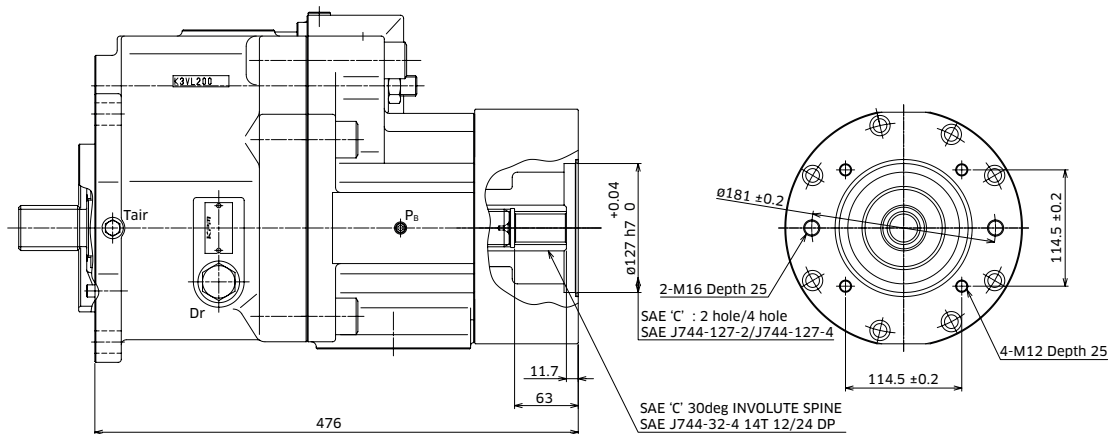

SAE 'C4' Throughdrive

Please contact KPM UK for dimensions.

SAE 'C-C' Throughdrive

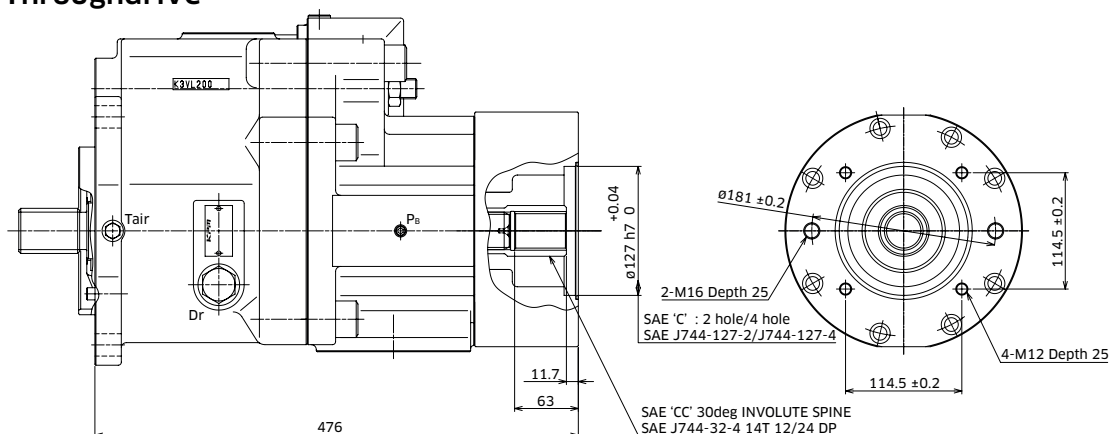

3-6 K3VL200H Installation (cont)

SAE 'D' Throughdrive

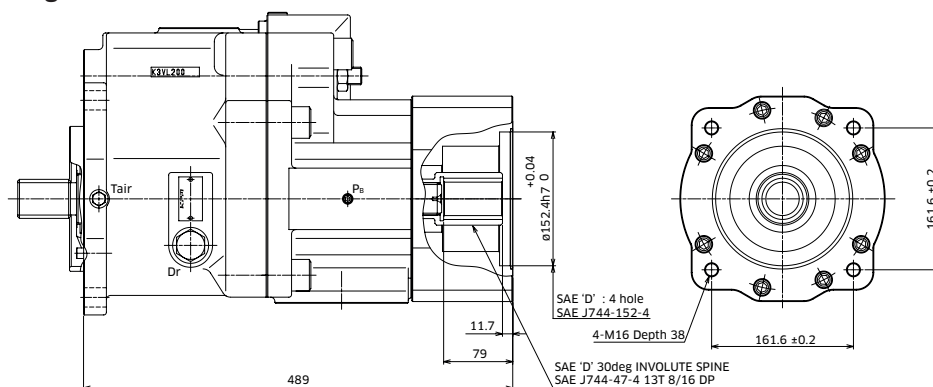

SAE 'E' Throughdrive

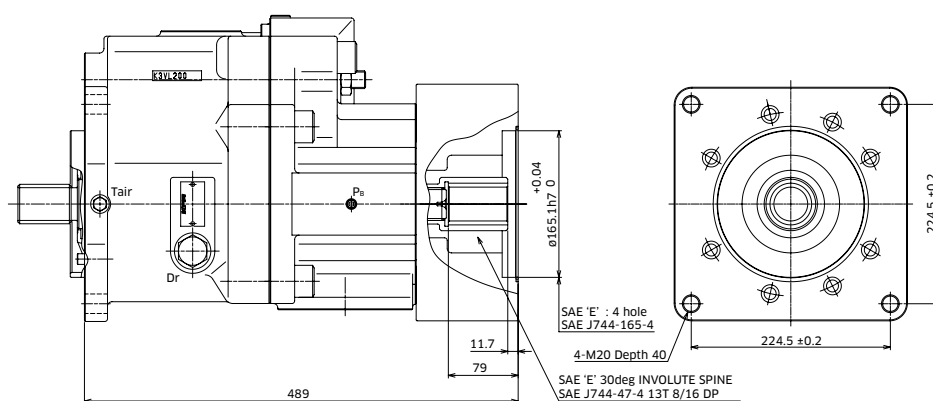

Part Name	Qty	SAE 'A'	SAE 'B'	SAE 'BB'	SAE 'C'
Coupling K3VL200	1	Item 116	Item 116	Item 116	Item 116
Sub Plate K3VL200	1	Item 317	Item 317	Item 317	Item 317
SHCS	8	Item 407	Item 407	Item 407	Item 407
O-Ring	1	Item 743	Item 743	Item 743	Item 743
O-Ring	1	Item 742	Item 742	Item 742	Item 742

Part Name	Qty	SAE 'C4'	SAE 'CC'	SAE 'D'	SAE 'E'
Coupling K3VL200	1	Item 116	Item 116	Item 116	Item 116
Sub Plate K3VL200	1	Item 317	Item 317	Item 317	Item 317
SHCS	8	Item 407	Item 407	Item 407	Item 407
O-Ring	1	Item 743	Item 743	Item 743	Item 743
O-Ring	1	Item 742	Item 742	Item 742	Item 742

3-7 Electrical & Hydraulic Displacement Control Installation (Type Q0, E*)

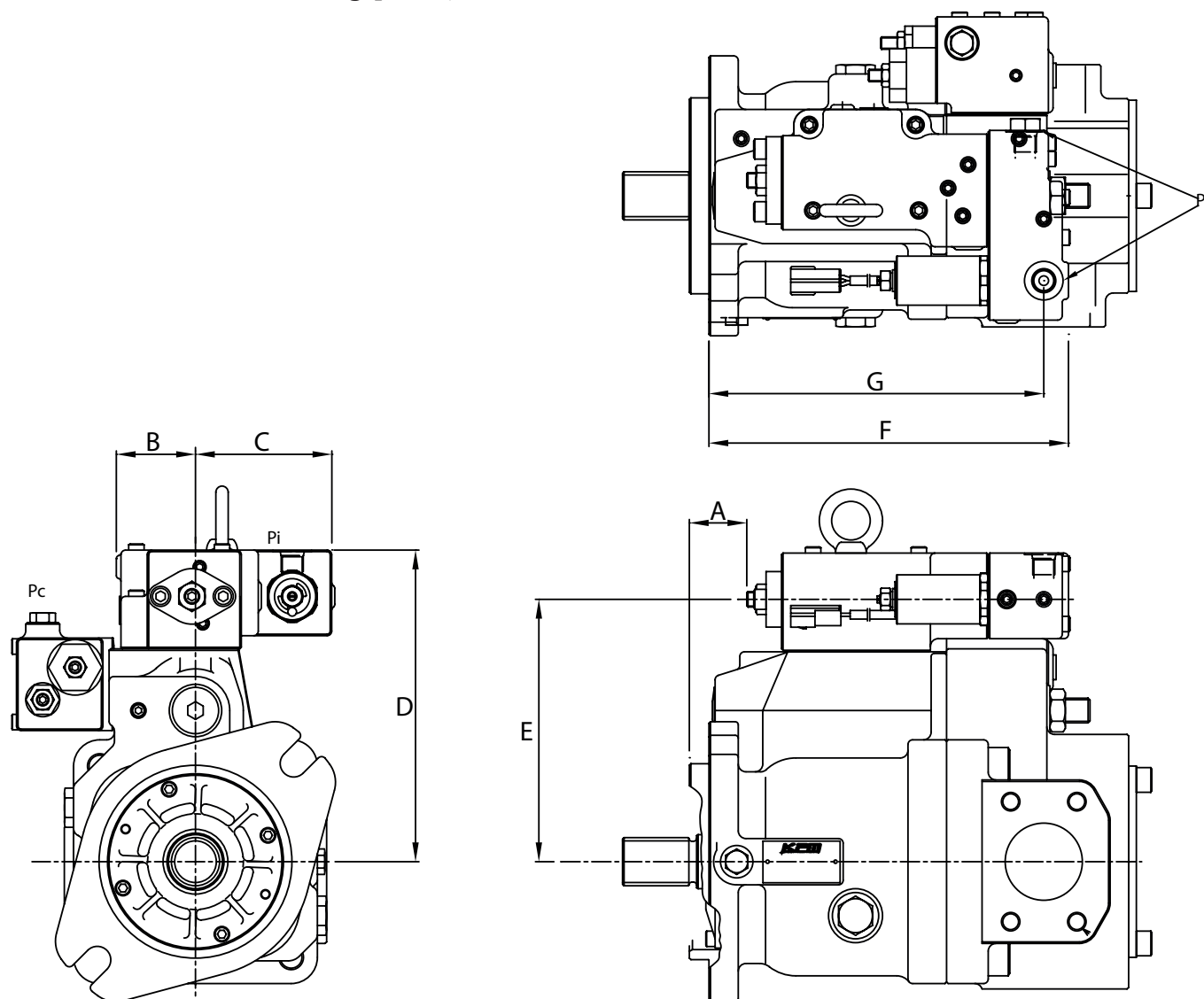

Installation Dimensions (mm)

Pump Size	A	B	C	D	E	F	G
K3VL45/60	21	52	90	187	157	226	210
K3VL80	25	59	83	202	172	233	217
K3VL112/140	38	64	78	244	214	247	231
K3VL200(H)	57	61	80	258	229	257	249

3-8 Unloading & Proportional Pressure Control Installation

Unloading valve module (Type N, M)

Pump Size	A	B
K3VL45/60	169	155
K3VL80	169	166
K3VL112/140	202	190
K3VL200(H)	212	205

Proportional pressure module (*V)

Pump Size	A	B
K3VL45/60	179	233
K3VL80	179	244
K3VL112/140	212	280
K3VL200(H)	222	295

A: Distance between the centre line of the pump and the top of the bolt head for the cut off regulator.

B: Distance between the centre line of the pump and top of the solenoid valve.

Unloading valve module (Type N, M)

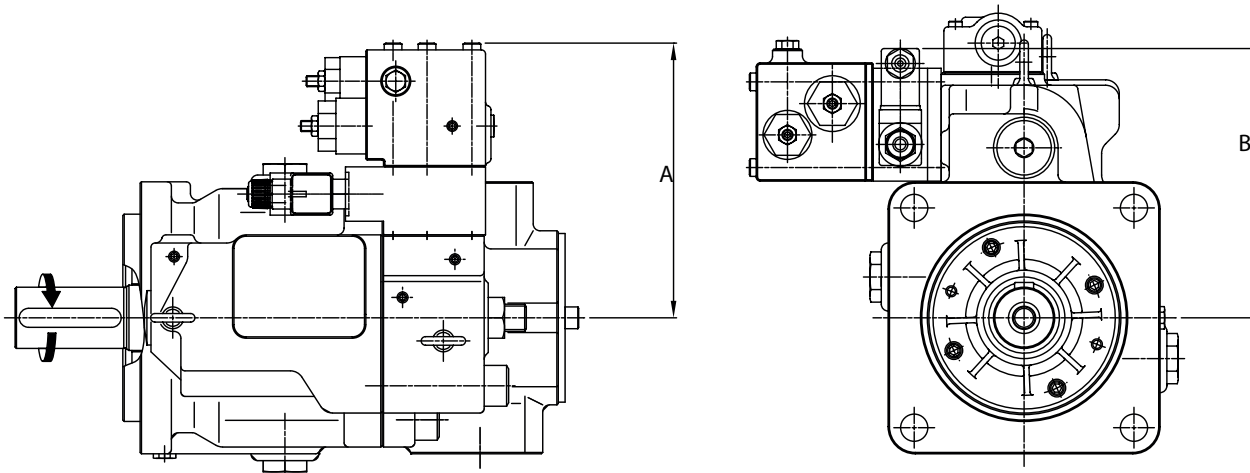

Proportional pressure module (*V)

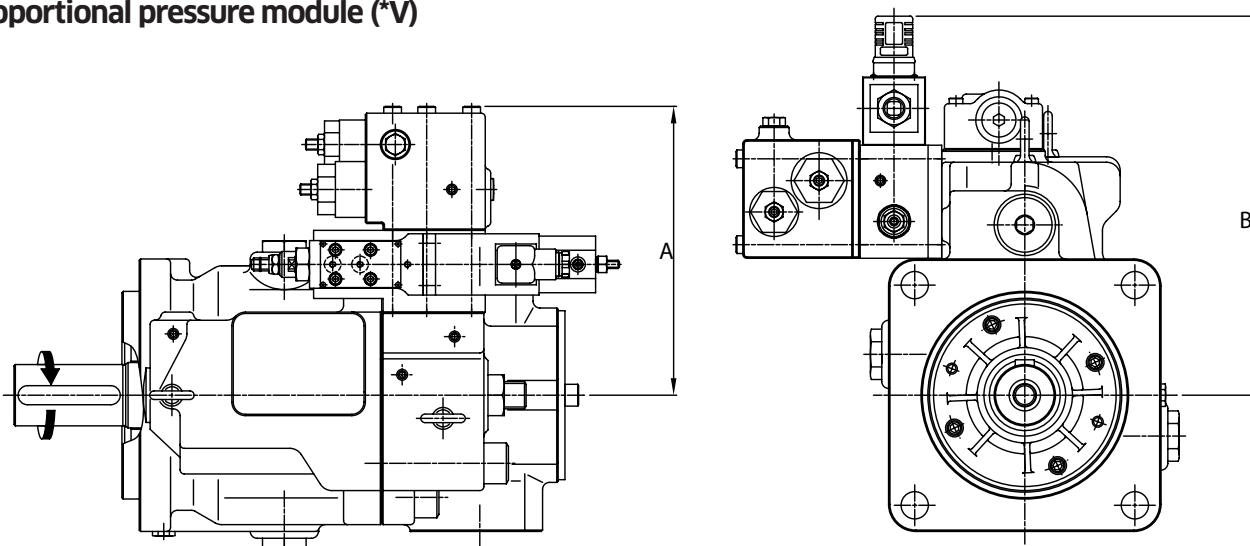

3-9 Power Shift Control Installation

/2-** Hydraulic Power Shift

Pump Size	A	B	C
K3VL80	182	59	5
K3VL112/140	224	59	4B 33.7
			2B 63.7
K3VL200(H)	239	59	51.5

/3-** Electronic Power Shift

Pump Size	A	B	C
K3VL80	193	80	3.5
K3VL112/140	235	80	4B 18.5
			2B 48.5
K3VL200(H)	249.5	80	36

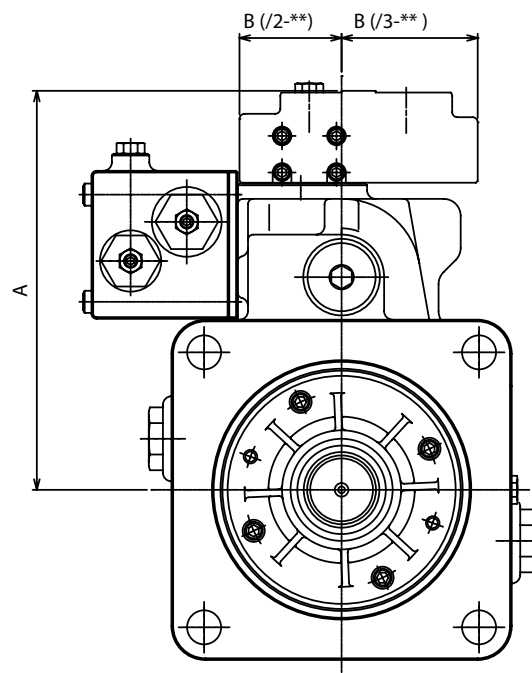
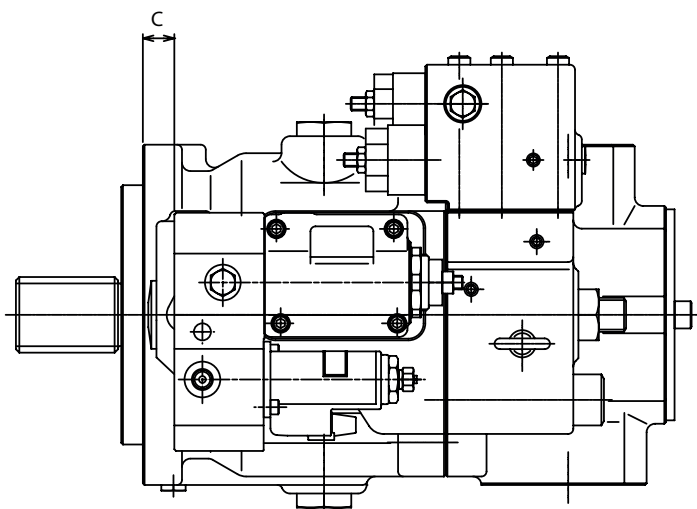

3-10 Calibration of Regulators

Max displacement adjustment	Pump	K3VL45	K3VL60	K3VL80	K3VL112	K3VL140	K3VL200(H)
Adj. screw Allen key size	mm	8	8	8	10	10	10
Displacement change per turn	cm ³	4.9	6.1	6.0	11.5	12.0	15.3
Adjustable range of displacement	cm ³	16-45	24-60	35-80	56-112	70-140	100-200
Length of adjustment range (L)	mm	0.5-12.1	0.5-12.1	0.5-15.0	3.8-16	1.0-16	8.9-25.3
Lock nut size	mm	24	24	24	30	30	30
Lock nut tightening torque	Nm	128	128	128	235	235	235

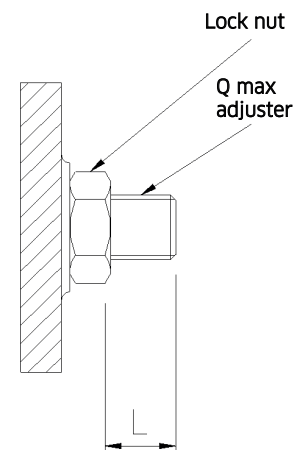

Regulator Adjustment	Pump	K3VL28/45 /60/80	K3VL112 /140/200
Adjustment screw Allen key size	mm	4	4
Pressure cut off change per turn	bar	80	100
Differential pressure change per turn	bar	13	14
Lock nut size (across flats)	mm	8	8
Lock nut tightening torque	Nm	16	16

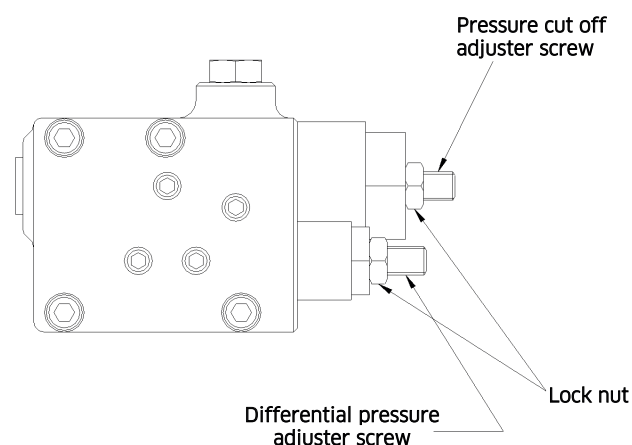

*1 Clockwise rotation of a screw produces an increase of the adjustment

Torque limiter adjustments

Outer spring adjuster screw: external hex	mm	27
Outer spring lock nut size	mm	41
Outer spring lock nut tightening torque	Nm	102
Inner spring adjuster screw: internal hex	mm	4
Inner spring lock nut size	mm	13
Inner spring lock nut tightening torque	Nm	16

Torque limiter module

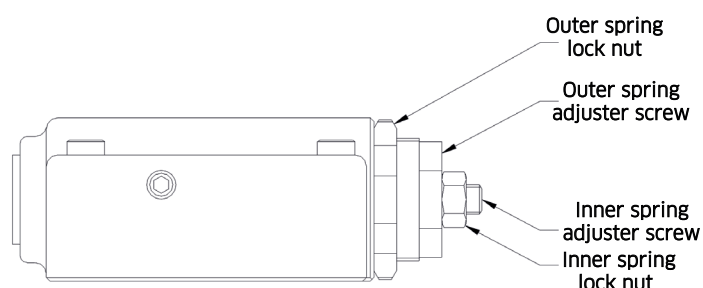

Torque limiter curve

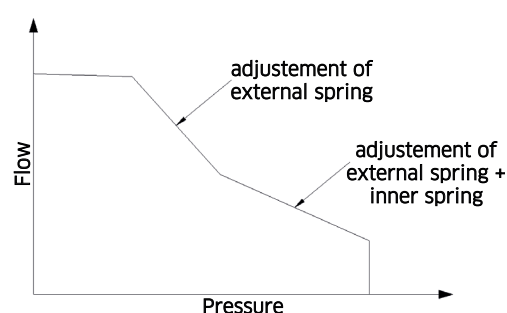

NOTES

NOTES

**KAWASAKI PRECISION
MACHINERY (UK) LTD**

Ernesettle, Plymouth
Devon, PL5 2SA, England

Tel: +44 1752 364394
Fax: +44 1752 364816
Mail: info@kpm-uk.co.uk
Website: www.kpm-eu.com

OTHER GLOBAL SALES OFFICES

JAPAN

Kawasaki Heavy Industry Ltd, Precision Machinery Ltd. Tokyo Office World
Trade Center Bldg.
4-1 Hamamatsu-cho
2-chome, Minato-ku
Tokyo 105-6116
Japan
Tel: +81-3-3435-6862
Website: www.khi.co.jp/kpm

U.S.A

Kawasaki Precision Machinery (U.S.A.), Inc.
3838 Broadmoor Avenue S.E.
Grand Rapids
Michigan 49512
U.S.A.
Tel: +1-616-975-3101
Website: www.kpm-usa.com

CHINA

Kawasaki Precision Machinery Trading (Shanghai) Co., Ltd. 17th Floor (Room
1701), The Headquarters Building No168 XiZang Road (M)
Huangpu District
Shanghai 200001
China
Tel: +86-021-3366-3800

KOREA

Flutek, Ltd.
192-11, Shinchon-dong
Changwon
Kyungnam 641-370
Korea
Tel: +82-55-286-5551
Website: www.flutek.co.kr

**The specified data is for product description purposes only
and may not be deemed to be guaranteed unless expressly
confirmed in the contract.**

Data sheet: P-2001/04.18