

Flow Monitor & Flow Indicator

KM-165, KM-185,

KM-200

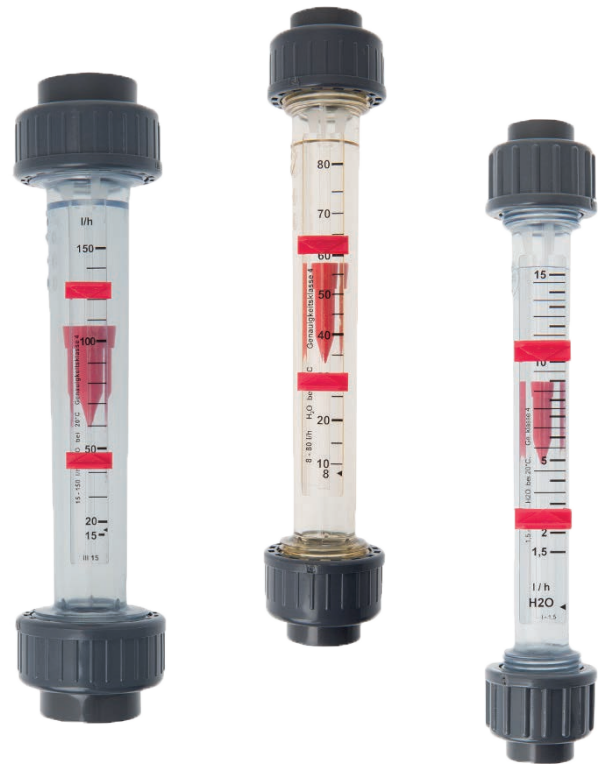

OVERVIEW

Operation

- Float measuring principle

Application

- Cooling systems and cooling circuits
- Mechanical engineering
- Pharmaceutical industry
- Chemical industry
- Research & Development

Features

- Shatterproof and corrosion resistant
- Easily removable from the pipe system
- Mounting for accessories (limit switches)
- Adhesive special scales, for liquid and gaseous media
- DN (rated width), measuring range, and material specified on the measuring tube

Installation information

- The operating instructions for KM-165, KM-185, KM-200 must be observed!
- **Download: www.meister-flow.com**

OPERATING DATA

Operating pressure, max.	PN 10 (at 20 °C) ⁽¹⁾
Pressure drop	see table on page 5
Operating temperature	0 °C - 60 °C ⁽²⁾
Measuring accuracy	see table below

⁽¹⁾ See also Pressure - temperature - diagram on page 5

⁽²⁾ max. temperature at 1 bar

MATERIALS

Measuring tube:	PVC, PSU
Float:	PVDF
Top insert:	PVDF
Coupling ring:	PVC (optional PP)
Connector:	PVC (optional PP)
O-Ring:	EPDM (optional FPM)
Limit value indicator:	PS

ACCURACY

Accuracy class 4, VDE/VDI 3513, sheet 2

Flow in %	10	20	30	40	50	60	70	80	90	100
Total error of measurement in %	13	8	6,33	5,5	5	4,67	4,43	4,25	4,11	4
Total error of full scale in %	1,3	1,6	1,9	2,2	2,5	2,8	3,1	3,4	3,7	4

MEASURING RANGES

Type	Measuring range for H ₂ O at 20 °C ⁽³⁾	
	l/h	gpm
KM-165-15	1,5 – 15	0,006 – 0,066
KM-165-25	2,5 – 25	0,01 – 0,11
KM-165-50	5 – 50	0,02 – 0,22
KM-165-100	10 – 100	0,04 – 0,44
KM-185-80	8 – 80	0,035 – 0,35
KM-185-150	15 – 150	0,06 – 0,66
KM-185-200	20 – 200	0,08 – 0,8
KM-200-150	15 – 150	0,06 – 0,66
KM-200-300	30 – 300	0,13 – 1,3
KM-200-500	50 – 500	0,22 – 2,2
KM-200-1000	100 – 1000	0,44 – 4,4

⁽³⁾ The specified measuring- / switch ranges are valid for water having a density of 1.00 kg/dm³, vertical installation of the device and flow direction from bottom to top.

Other installation positions or deviation from the operating densities will increase the measurement error specified in the data sheet.

Operating density for water at 20 °C and 1.013 bar (absolute value): 1.00 kg/dm³.

Upon request, special scales for deviating media and different operating conditions are available.

Special scales for air see pages 6 and 7

Special scales for HCl 30 - 33 %, NaOH 30 % and NaOH 50 % see page 7

ASSEMBLY DRAWING

Process connection with solvent cement socket PVC or weld socket PP

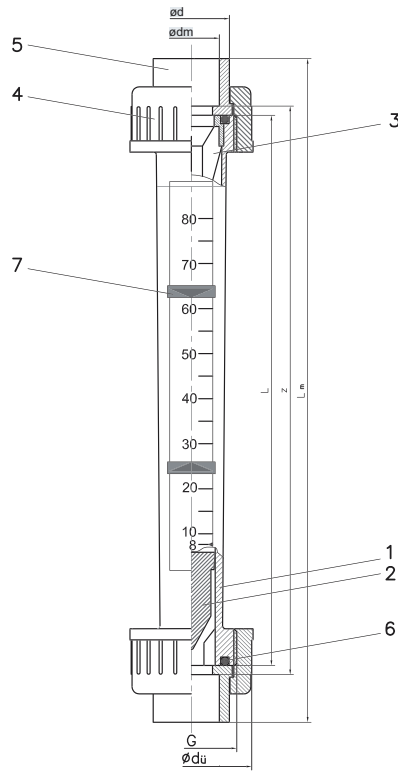

PARTS DESCRIPTION

Item	Description	No. of pieces	Material
01	Measuring tube:	1	PVC, PSU
02	Float:	1	PVDF
03	Top insert:	1	PVDF
04	Coupling ring:	2	PVC (optional PP)
05	Connector:	2	PVC (optional PP)
06	O-Ring:	2	EPDM (optional FPM)
07	Limit value indicator:	2	PS

TECHNICAL DRAWING

Process connection with weld socket (butt end) PP

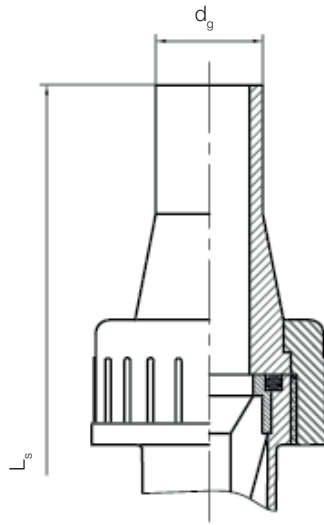

Process connection with threaded socket PVC, PP annealed cast iron or stainless steel

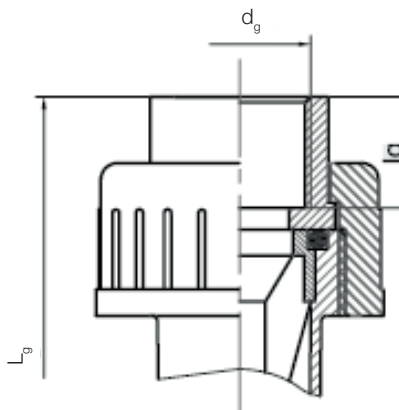

SUMMARY OF TYPES

Type	Overall dimensions [mm]				Solvent cement socket PVC			Weld socket PP			PP-Socket (butt end)			Threaded socket			Weight ⁽⁴⁾ [g]
	DN	d _u	G	L	d _m	z	L _m	d _m	z	L _m	d _g	L _s	S ⁽⁵⁾	d _g	L _g	l _g	
KM-165-15	10	35	3/4"	165	16	171	199	-	-	-	-	-	-	3/8"	199	11	80
KM-165-25	10	35	3/4"	165	16	171	199	-	-	-	-	-	-	3/8"	199	11	80
KM-165-50	10	35	3/4"	165	16	171	199	-	-	-	-	-	-	3/8"	199	11	80
KM-165-100	10	35	3/4"	165	16	171	199	-	-	-	-	-	-	3/8"	199	11	80
KM-185-80	15	43	1"	185	20	191	223	19,5	195	223	20	293	1,9	1/2"	223	13	130
KM-185-150	15	43	1"	185	20	191	223	19,5	195	223	20	293	1,9	1/2"	223	13	130
KM-185-200	15	43	1"	185	20	191	223	19,5	195	223	20	293	1,9	1/2"	223	13	130
KM-200-150	25	60	1 1/2"	200	32	206	250	31,5	210	246	32	320	2,9	1"	250	17	240
KM-200-300	25	60	1 1/2"	200	32	206	250	31,5	210	246	32	320	2,9	1"	250	17	240
KM-200-500	25	60	1 1/2"	200	32	206	250	31,5	210	246	32	320	2,9	1"	250	17	240
KM-200-1000	25	60	1 1/2"	200	32	206	250	31,5	210	246	32	320	2,9	1"	250	17	240

⁽⁴⁾ PSU version

⁽⁵⁾ Wall thickness

COMBINATIONS

Measuring tube	Float	Insert upper and lower	O-Ring
PVC	PVDF	PVDF	EPDM (optional FPM)
PSU	PVDF	PVDF	EPDM (optional FPM)

CONNECTION OPTIONS

Socket	Socket (butt end)	Plastic, internal thread	Metal, internal thread
PVC solvent cement socket (standard)	PP weld socket (butt end)	PVC	Stainless steel V4A
PP weld socket		PP	Annealed cast iron

PRESSURE DROP

Type	Measuring range		Pressure drop	
	l/h	mm WS	mbar	
KM-165-15	1,5 – 15	46	4,6	
KM-165-25	2,5 – 25	46	4,6	
KM-165-50	5 – 50	46	4,6	
KM-165-100	10 – 100	46	4,6	
KM-185-80	8 – 80	44,7	4,47	
KM-185-150	15 – 150	44,7	4,47	
KM-185-200	20 – 200	44,7	4,47	
KM-200-150	15 – 150	82,8	8,28	
KM-200-300	30 – 300	82,8	8,28	
KM-200-500	50 – 500	82,8	8,28	
KM-200-1000	100 – 1000	82,8	8,28	

PRESSURE - TEMPERATURE - DIAGRAM

The curves in the diagram represent values for the durability of three different materials in relation to the operating temperature.

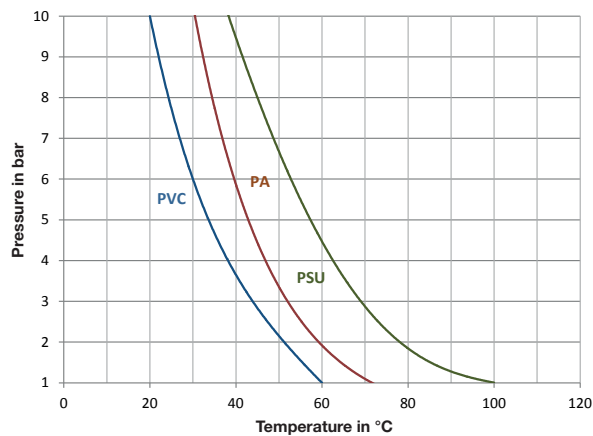

SPECIAL SCALES

Type	Measuring range				
	H ₂ O	Air	Air	Air	Air
	I/h	0 bar Nm ³ /h	1 bar Nm ³ /h	2 bar Nm ³ /h	3 bar Nm ³ /h
KM-165-15	1,5 – 15	0,1 – 0,55	0,15 – 0,8	0,17 – 0,9	0,2 – 1,1
KM-165-25	2,5 – 25	0,2 – 0,95	0,25 – 1,3	0,3 – 1,6	0,4 – 1,9
KM-165-50	5 – 50	0,5 – 1,9	0,7 – 2,7	0,8 – 3,4	1 – 3,8
KM-165-100	10 – 100	0,8 – 3	1 – 4,2	1,2 – 5,4	1,4 – 6,4
KM-185-80	8 – 80	0,6 – 2,8	0,8 – 4	1 – 5	1,2 – 5,6
KM-185-150	15 – 150	1,4 – 5,6	2 – 8	2 – 10	3 – 12
KM-185-200	20 – 200	1,5 – 7	2 – 10	3 – 13	3 – 15
KM-200-150	15 – 150	1 – 6,5	1 – 9	1,5 – 11	2 – 13
KM-200-300	30 – 300	1,5 – 11	2 – 15	2,5 – 18	3 – 22
KM-200-500	50 – 500	3 – 18	4 – 25	5 – 30	5 – 35
KM-200-1000	100 – 1000	6 – 30	8 – 44	10 – 54	12 – 62

Type	Measuring range				
	H ₂ O	Air	Air	Air	Air
	I/h	4 bar Nm ³ /h	5 bar Nm ³ /h	6 bar Nm ³ /h	7 bar Nm ³ /h
KM-165-15	1,5 – 15	0,25 – 1,2	0,25 – 1,3	0,26 – 1,45	0,3 – 1,5
KM-165-25	2,5 – 25	0,4 – 2,1	0,5 – 2,4	0,5 – 2,5	0,5 – 2,7
KM-165-50	5 – 50	1,2 – 4,2	1,2 – 4,6	1,2 – 5	1,4 – 5,4
KM-165-100	10 – 100	1,6 – 7	1,6 – 7,4	2 – 8	2 – 8,8
KM-185-80	8 – 80	1,4 – 6,4	1,4 – 7	1,5 – 7,5	1,5 – 8
KM-185-150	15 – 150	3 – 13	3 – 14	3,5 – 15	3,5 – 16,5
KM-185-200	20 – 200	4 – 17	4 – 18	4 – 20	5 – 21
KM-200-150	15 – 150	2 – 14,5	2 – 16	2 – 17	2,5 – 18
KM-200-300	30 – 300	3 – 24	4 – 26	4 – 28	4 – 30
KM-200-500	50 – 500	6 – 40	6 – 44	8 – 48	8 – 50
KM-200-1000	100 – 1000	12 – 70	15 – 75	15 – 80	15 – 85

Type	Measuring range			
	H ₂ O	Air 8 bar	Air 9 bar	Air 10 bar
	l/h	Nm ³ /h	Nm ³ /h	Nm ³ /h
KM-165-15	1,5 – 15	0,3 – 1,6	0,3 – 1,7	0,35 – 1,8
KM-165-25	2,5 – 25	0,6 – 2,9	0,6 – 3	0,6 – 3,2
KM-165-50	5 – 50	1,4 – 5,8	1,6 – 6	1,6 – 6,4
KM-165-100	10 – 100	2 – 9	2 – 10	2 – 10
KM-185-80	8 – 80	1,5 – 8,5	2 – 9	2 – 9,5
KM-185-150	15 – 150	4 – 17	4 – 18	4 – 19
KM-185-200	20 – 200	5 – 23	5 – 23	5 – 25
KM-200-150	15 – 150	2,5 – 19,5	3 – 20	3 – 21
KM-200-300	30 – 300	4 – 33	5 – 34	5 – 35
KM-200-500	50 – 500	8 – 54	8 – 56	10 – 60
KM-200-1000	100 – 1000	20 – 90	20 – 95	20 – 100

Type	Measuring range			
	H ₂ O	HCl 30 - 33% ⁽⁶⁾	NaOH 30 %	NaOH 50 %
	l/h	l/h	l/h	l/h
KM-165-15	1,5 – 15	1 – 10	0,1 – 2	–
KM-165-25	2,5 – 25	2,5 – 20	0,2 – 5	–
KM-165-50	5 – 50	5 – 40	1 – 14	–
KM-165-100	10 – 100	10 – 85	3 – 35	–
KM-185-80	8 – 80	8 – 70	2 – 23	0,2 – 3,5
KM-185-150	15 – 150	15 – 125	3 – 55	0,5 – 10
KM-185-200	20 – 200	20 – 170	5 – 80	0,5 – 16
KM-200-150	15 – 150	15 – 125	3 – 55	0,5 – 11
KM-200-300	30 – 300	30 – 260	6 – 130	1 – 33
KM-200-500	50 – 500	50 – 425	10 – 250	2 – 80
KM-200-1000	100 – 1000	100 – 850	40 – 600	10 – 220

⁽⁶⁾ PSU version

■ LIMIT SWITCH CONTACT ZNC AND ZNO

■ APPLICATION

The limit switch contacts are used to monitor flow limits. They are slid onto the guide located on the flowmeter and can be set to any value of the corresponding scale.

■ ILLUSTRATION



■ OPERATION

A built-in magnet in the float closes or opens a Reed contact encapsulated in the switch housing. The switching function is bistable, that is, the switching state is maintained, even when the magnetic float is away from the contact.

■ SWITCHING STATE

Contact		Float (above)	Float (below)
ZNC	(Normally closed) / MIN	open	closed
ZNO	(Normally open) / MAX	closed	open

■ TECHNICAL DATA

Switching voltage ⁽⁷⁾	max. 230 V~
Switching capacity ⁽⁷⁾	max. 10 W / 12 VA
Switching current ⁽⁷⁾	max. 0,5 A
Contact resistance	< 200 mΩ
Insulation resistance	> 10 ¹¹ Ω
Permissible ambient temperature	0 °C - 55 °C
Ingress Protection	IP65 (DIN 40050)
Switch-on / -off hysteresis	1 - 2 mm

⁽⁷⁾ Exceeding these values, even temporarily, is not allowed.