

1.7. Rotary Cam Switch LNSW

LEONARD rotary cam switches LNSW (see figure 1.7.1) are cased in housings made of cast aluminum and fitted out with mechanic switching elements. The technical data of all available switching elements are listed in figure 1.0.1.

The rotary cam switches LNSW are normally available with 3, 6, 9 and 12 switching elements. The cam shaft (spindle) comes out on both sides of the housing so that several switches can be coupled together. The second end of the shaft, which is normally unused, is protected by a safety cover. The cam shaft is mounted in two deep groove ball bearings and maintenance-free.

To actuate the individual switching elements the cam shaft is fitted with cam disk sets in a pitch of 30 mm. Each cam disk set consists of the components listed in figure 1.7.2.

The infinitely adjustable cam disk sets, which run almost entirely free from unbalance by virtue of their special design, are individually tensioned by disc springs. This tension is such that all cam disk sets can be adjusted when the clamp nut is slackened. After setting all the cam disk sets the complete adjustment can be checked on start up for trial operation. Only after all switching adjustments have been tested, the clamp nut is tightened against the disc spring. All cam disk sets are positively located in the position set.

The cam rings, which have a diameter of 120 mm, are made of wear-resistant plastic. The cam disk sets are mounted immediately beside a graduated disk made of die-cast aluminum. The cam rings as well as the graduated disks have an angular scale of 360°, though a precise switching angle resolution is provided.

All parts of the switching element actuator (see figure 1.7.3) are of zinc die-casting and surface treated or of acid-resisting stainless steel. The roller is produced from wear-resistant plastic and is self lubricating. The rotary cam switches dispose of ideal anti-friction properties. Therefore the wear of the rollers in the roller levers is reduced to a minimum.

The housing of the rotary cam switch is made of aluminum alloy and painted in RAL6011. Optional the switch can be supplied in a seawaterproof performance. The housing is divided into the bottom section and the top section at the spindle centre. Both parts are eternal connected by hinges and screws of stainless steel. The rotary cam switch could be mounted with 3 screws M8. Please have a look at all dimensions in figure 1.7.4 and figure 1.7.5.

For driving the LEONARD rotary cam switch LNSW the gearbox GVL is suitable.



Fig. 1.7.1:
Rotary Cam Switch LNSW 12 RD
without Cover

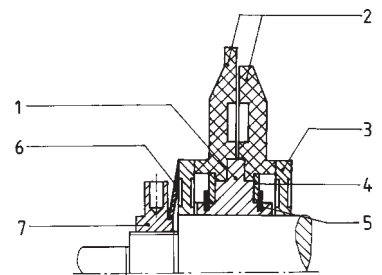

Fig. 1.7.2: Cam Disk Set LNSW

- | | |
|--------------------|-------------------|
| 1 = carrier disk | 5 = retainer ring |
| 2 = cam rings | 6 = clamp spring |
| 3 = graduated disk | 7 = clamp nut |
| 4 = plate spring | |

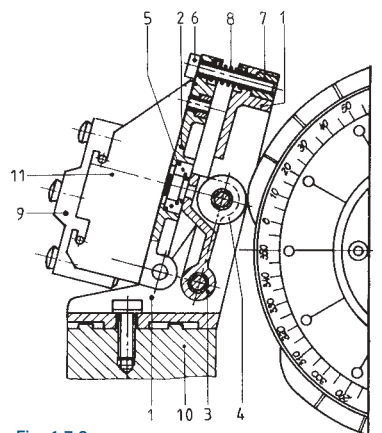

Fig. 1.7.3:

Switching Element Actuator LNSW

- | | |
|----------------------|------------------------|
| 1 = bracket | 8 = compression spring |
| 2 = contact holder | 9 = switching element |
| 3 = roller lever | 10 = contact strip |
| 4 = roller | 11 = support frame |
| 5 = return spring | |
| 6 = adjusting screw | |
| 7 = self-locking nut | |

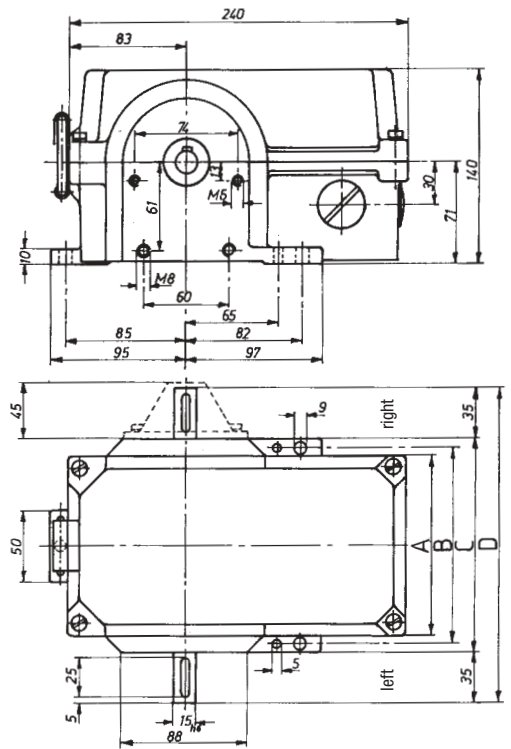

Fig. 1.7.5: Table of Dimensions LNSW (without gear)

type	number of cable entries M32	A [mm]	B [mm]	C [mm]	D [mm]	weight [kg]
LNSW 03	3	150	160	175	245	6,0
LNSW 06	4	250	260	275	345	9,0
LNSW 09	5	335	344	360	430	12,5
LNSW 12	6	430	440	455	525	14,5

Fig. 1.7.4: Dimensioned Drawing LNSW

Ordering instructions for type LNSW:

type	number of switching elements *1)	type of switching elements	gearbox *2)	ratio *2)	drive side (input) *3)
------	----------------------------------	----------------------------	-------------	-----------	------------------------

Product overview:

LNSW	03 06 09 12	MNS MNSG RD HSÖ HSS	[no statement] GVL	[no statement] Have a look at the technical data of our gearboxes!	[no statement] l [left side] r [right side]
------	----------------------	---------------------------------	-----------------------	---	---

Example:

LNSW 06 MNS GVL 175:1 l

*1) If the rotary cam switch is not fitted out with the complete number of switching elements, we need the max. possible number of switching elements. The actually fitting must be described "in plain text"!

*2) We don't need this information for a rotary cam switch without a gearbox.

*3) If this information is missing, the input is on the right side of the switch.

If you need a rotary cam switch with different switching elements or a switch in a special design, please give a precise description "in plain text"!