

Incremental Rotary Encoder G71

Shaft: Type S / H



- Housing diameter: 64 mm
- Shaft: \varnothing 8 ... 12,692 mm
- Hollow shaft: \varnothing 6 ... 20 mm
- Line counts: 2 ... 10.000
- Output signals:
RS422, PP, TTL, OC, 1Vpp, 11 μ App
- Connector- or cable output;
axial or radial

Hollow shaft: Type W



Mechanical Data

G71	Shaft Type S	Shaft Type H	Hollow shaft Type W
	\varnothing Shaft / Hollow shaft	9,52 mm	12,692 mm
Weight	ca. 450 g	ca. 480 g	ca. 250 g
Accuracy (up to line count 2500)	$< \pm \frac{360^\circ}{\text{Line counts} \times 20}$	$< \pm \frac{360^\circ}{\text{Line counts} \times 20}$	$< \pm \frac{360^\circ}{\text{Line counts} \times 20}$
Mech. permissible speed	max. 12.000 min ⁻¹	max. 12.000 min ⁻¹	max. 12.000 min ⁻¹
Starting torque (25°C) without shaft seal with shaft seal	< 0,01 Nm < 0,04 Nm	< 0,02 Nm < 0,06 Nm	< 0,01 Nm ---
Shaft load at 12.000 min ⁻¹	80 N axial; 120 N radial	110 N axial; 130 N radial	---
Rotor inertia	3,5 x 10 ⁻⁶ kgm ²	3,5 x 10 ⁻⁶ kgm ²	3,5 x 10 ⁻⁶ kgm ²
Vibration	100 m/s ² ; higher upon request	100 m/s ² ; higher upon request	100 m/s ² ; higher upon request
Shock	1000 m/s ² ; higher upon request	1000 m/s ² ; higher upon request	1000 m/s ² ; higher upon request
Operating temperature	-10°C ... +80°C -40°C ... +100°C upon request	-10°C ... +80°C -40°C ... +100°C upon request	-10°C ... +80°C -40°C ... +100°C upon request
Protection class	IP 64; IP 66 upon request	IP 64; IP 66 upon request	IP 64; IP 66 upon request

Line counts

2	8	10	25	50	64	100	120	125	128	150	160	180	190	200	240	250	254
256	300	350	360	380	400	500	512	560	600	604	625	635	676	720	750	800	900
1000	1024	1125	1130	1152	1200	1250	1270	1440	1500	1600	1800	2000	2048	2160	2164	2200	2400
2500	2540	2592	2670	3000	3092	3142	3600	3927	4000	4096	4490	5000	5760	8192	9000	10000	

LTN Servotechnik GmbH

Dimensions (mm)

G 71 S

- optional: flange square
- higher vibration capability upon request
- optional: sealed bearing
- optional: shaft seal
- connector output: radial or axial
- cable output: radial or axial
- ② optional: servo clamps

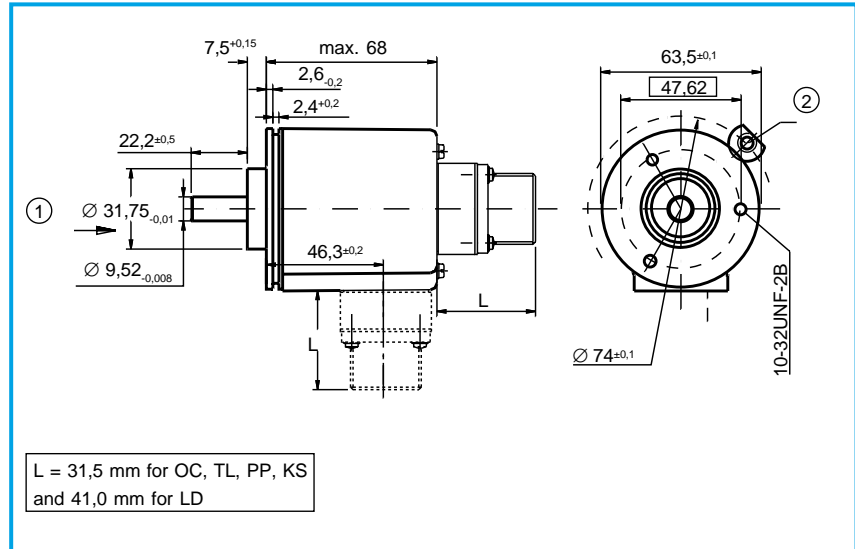

G 71 H

- optional: servo flange
- higher vibration capability upon request
- standard: sealed bearing
- optional: shaft seal
- connector output: radial or axial
- cable output: radial or axial

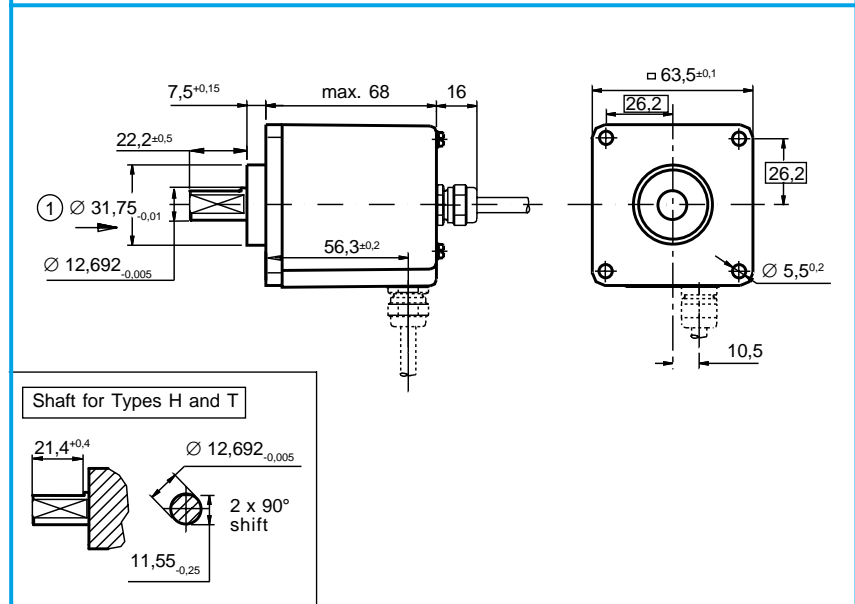

G 71 W

- hollow through shaft
- optional: sealed bearing
- connector- or cable output: radial
- axial backlash (shaft): max. ± 1 mm
- ③ torque coupling included

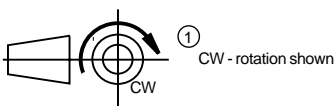
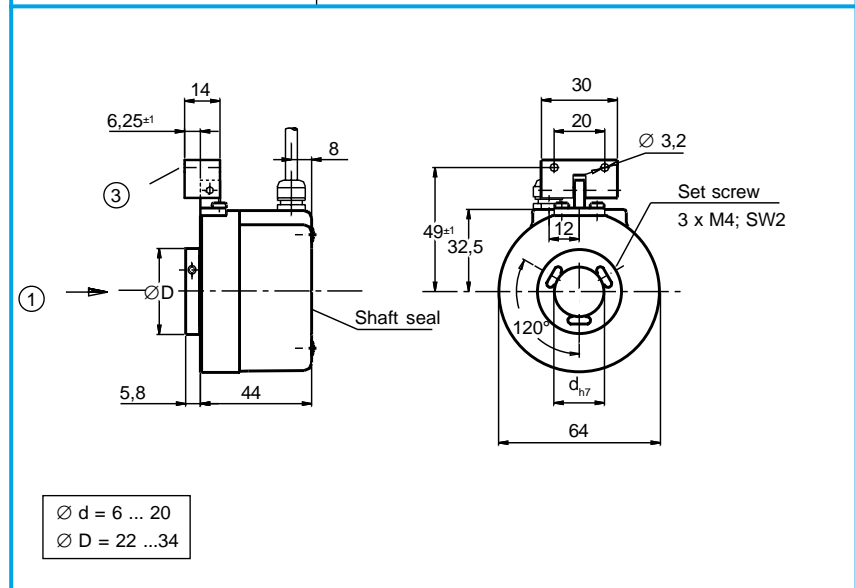

Electrical Data

G71	Type S	Type H	Type W
Supply voltage	5 V or 8 ... 30 V: LD, PP, TL, OC, QI, SI 8 ... 30 V: KS	5 V or 8 ... 30 V: LD, PP, TL, OC, QI, SI 8 ... 30 V: KS	5 V: QI, SI 5 V or 8 ... 30 V: LD, PP, TL, OC 8 ... 30 V: KS
Current requirement (without load)	max. 180 mA: LD, PP, KS, TL, OC, SI max. 100 mA: QI	max. 180 mA: LD, PP, KS, TL, OC, SI max. 100 mA: QI	max. 180 mA: LD, PP, KS, TL, OC, SI max. 100 mA: QI
Output load	± 20 mA (RS422): LD 50 mA: PP, KS, OC 50 mA (3,3 kOhm): TL 8 mA: (120 Ohm): SI 11µApp (1 kOhm): QI	± 20 mA (RS422): LD 50 mA: PP, KS, OC 50 mA (3,3 kOhm): TL 8 mA: (120 Ohm): SI 11µApp (1 kOhm): QI	± 20 mA (RS422): LD 50 mA: PP, KS, OC 50 mA (3,3 kOhm): TL 8 mA: (120 Ohm): SI 11µApp (1 kOhm): QI
Output frequency	0 ... 150 kHz: PP, KS, TL, OC 0 ... 160 kHz (-3dB): QI, SI 0 ... 300 kHz: LD	0 ... 150 kHz: PP, KS, TL, OC 0 ... 160 kHz (-3dB): QI, SI 0 ... 300 kHz: LD	0 ... 150 kHz: PP, KS, TL, OC 0 ... 160 kHz (-3dB): QI, SI 0 ... 300 kHz: LD
Cable length	max. 30 m: TL, OC, QI max. 50 m: PP, KS max. 100 m: LD max. 150 m: SI	max. 30 m: TL, OC, QI max. 50 m: PP, KS max. 100 m: LD max. 150 m: SI	max. 30 m: TL, OC, QI max. 50 m: PP, KS max. 100 m: LD max. 150 m: SI
Zero index	1 = Z „high“ if A „high“ 5 = Z „high“ if A + B „high“	1 = Z „high“ if A „high“ 5 = Z „high“ if A + B „high“	1 = Z „high“ if A „high“ 5 = Z „high“ if A + B „high“

Output signals

Version:

LD = Line driver RS422
 PP = Push pull
 KS = PP with short-cut protection
 TL = TTL compatible
 OC = Open collector

Version:

QI = 11 µApp at 1 kOhm load
 SI = 1 Vpp at 120 Ohm load

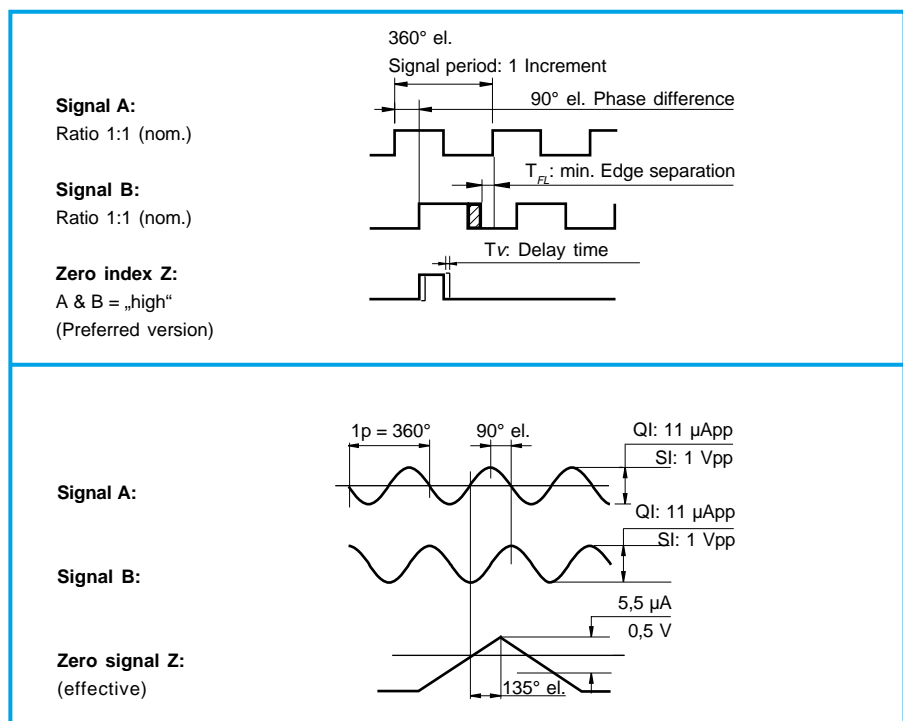

LTN Servotechnik GmbH

Connector-Terminal and Cable Designation

G 71 S, H	Output circuit			
	OC / TL / PP / KS		LD (RS422)	
Function / Signal	7-pin	Cable Pur 12 x 0,19	10-pin	Cable Pur 12 x 0,19
Signal A	A	green	A	green
Signal \bar{A}	-	-	G	blue
Signal B	B	yellow	B	yellow
Signal \bar{B}	-	-	H	black
Signal Z	C	grey	C	grey
Signal \bar{Z}	-	-	I	pink
V _{CC}	D	brown	D	brown
V _{CC Sense}	E	violet	E	violet
0 Volts	F	white	F	white
0 Volts _{Sense}	-	red	-	red
Shield	G	white-blue	J	white-blue

G 71 W	Output circuit			
	OC / TL / PP / KS		LD (RS422)	
Function / Signal	12-pin	Cable Pur 12 x 0,19	12-pin	Cable Pur 12 x 0,19
Signal A	5	green	5	green
Signal \bar{A}	-	-	6	blue
Signal B	8	yellow	8	yellow
Signal \bar{B}	-	-	1	black
Signal Z	3	grey	3	grey
Signal \bar{Z}	-	-	4	pink
V _{CC}	12	brown	12	brown
V _{CC Sense}	-	-	-	-
0 Volts	10	white	10	white
0 Volts _{Sense}	-	-	-	-
Shield	9	white-blue	9	white-blue

G 71	Output circuit			
	QI		SI	
Function / Signal	9-pin	Cable Pur 8 x 0,14	12-pin	Cable Pur 12 x 0,19
Signal A +	1	green	5	brown
Signal A -	2	yellow	6	green
Signal B +	5	blue	8	grey
Signal B -	6	red	1	pink
Signal Z +	7	grey	3	red
Signal Z -	8	pink	4	black
V _{CC}	3	brown	12	blue
V _{CC Sense}	-	-	2	violet
0 Volts	4	white	10	white
0 Volts _{Sense}	-	-	11	yellow
Shield	9	white-blue	9	case
External shield	-	case		

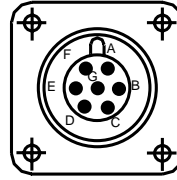

Square flange receptacle 7-pin:
MS3102A-16S-1P

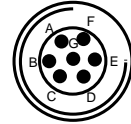

Pin plug 7-pin:
MS-3106A-16S-1P

Mating connector 7-pol.:
straight: MS3106A-16S-1S-200
90° angular: MS3108A-16S-1S-200

Socket coupling for pin plug:
MS3101A-16S-1S

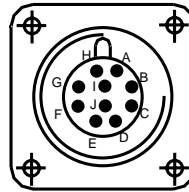

Square flange receptacle 10-pin:
MS3102A-18-1P

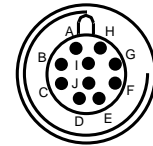

Pin plug 10-pin:
MS-3106A-18-1P

Mating connector 10-pol.:
straight: MS3106A-18-1S-200
90° angular: MS3108A-18-1S-200

Socket coupling for pin plug:
MS3101A-18-1S

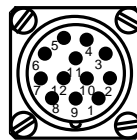

Square flange receptacle 12-pin:
RC-12P2N122K00

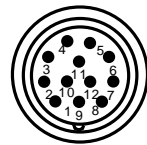

Pin plug 12-pin:
Metal: RC-12P2N1280EF
Plastic: RC-12P1N12K0EF

Mating connector 12-pol.:
Socket plug for square flange receptacle:
RC-12S2N1280EF

Socket coupling for pin plug:
Metal: RC-12S1N1290EF
Plastic: RC-12S1N12M0EF

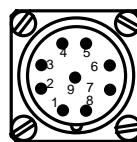

Square flange receptacle 9-pin:
RC-09P1N122K00

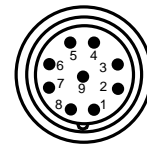

Pin plug 9-pin:
Metal: RC-09P1N1280EF
Plastic: RC-09P2N12K0EF

Mating connector 9-pol.:
Socket plug for square flange receptacle:
RC-09S1N1280EF

Socket coupling for pin plug:
Metal: RC-09S2N1290EF
Plastic: RC-09S2N12M0EF

LTN Servotechnik GmbH

Recommended input circuitry of subsequent electronics

LD: Line driver RS 422 A

Operating voltage: 5 V ± 5 % or 8 ... 30 V
 Current requirement: max. 180 mA (without load)
 Output signals: A, \bar{A} , B, \bar{B} , Z, \bar{Z}
 Max. output frequency: 300 kHz

Min. edge separation: $T_{FL} \geq 0,25 \mu\text{s}$ (400 kHz)
 Level (RS422): $V_H \geq 2,5 \text{ V}$ ($I_H = -20 \text{ mA}$)
 $V_L \leq 0,5 \text{ V}$ ($I_L = 20 \text{ mA}$)

Max. current load cap.: $I_{max} = \pm 20 \text{ mA}$ per output
 Delay time: $T_V \leq 50 \text{ ns}$
 Switching times: rise / fall times: $\leq 100 \text{ ns}$
 Cable length: max. 100 m
 Operating temperature: $-10 \text{ }^\circ\text{C} \dots +80 \text{ }^\circ\text{C}$

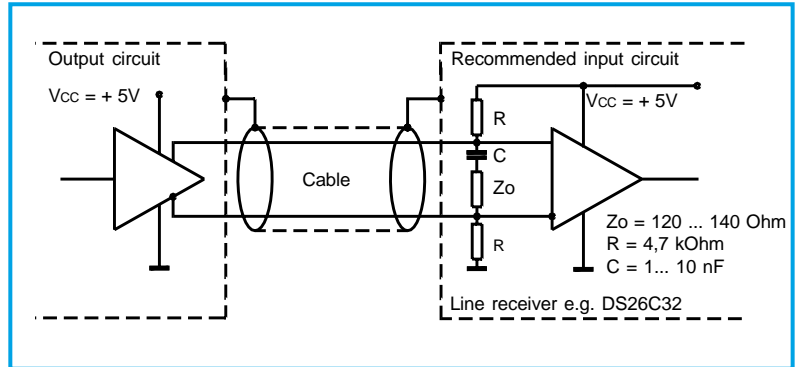

KS: Push pull output with short-circuit protection

Operating voltage: 8 ... 30 V
 Current requirement: max. 180 mA (without load)
 Output signals: A, B, Z
 max. output frequency: 150 kHz

Min. edge separation: $T_{FL} \geq 0,9 \mu\text{s}$ (400 kHz)
 Max. current load cap.: $I_{max} = 50 \text{ mA}$ per output
 Delay time: $T_V \leq 400 \text{ ns}$
 Switching times: rise / fall times: $\leq 350 \text{ ns}$
 (1 m cable and $I_{out} = 50 \text{ mA}$)

Cable length: max. 50 m
 Operating temperature: $-10 \text{ }^\circ\text{C} \dots +80 \text{ }^\circ\text{C}$

Short-circuit protection only at zero speed !

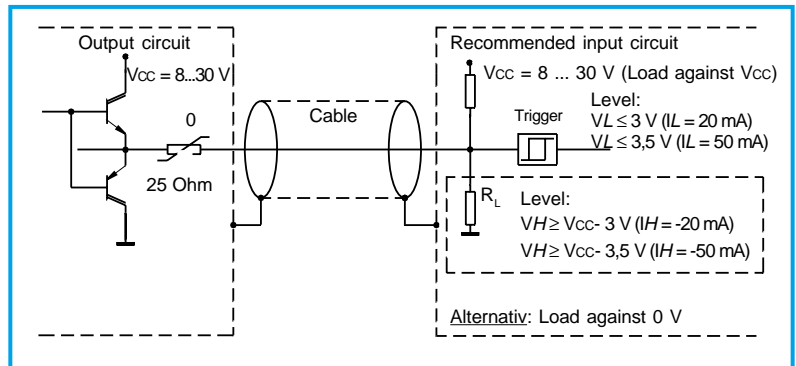

QI: Current interface 11 μApp

Operating voltage: 5 V ± 5 % or 8 ... 30 V
 Current requirement: max. 100 mA
 Output signals: A+, A-, B+, B-, Z+, Z-
 Limit frequency (-3dB): max. 160 kHz

Signal level at a load of 1 kOhm: track signals:
 A, B $\geq 11 \mu\text{App}$ (7 ... 16 μApp)
 index signal (effective signal):
 Z $\geq 5,5 \mu\text{A}$ (2 ... 8,5 μA)

Cable length: max. 30 m
 Operating temperature: $-10 \text{ }^\circ\text{C} \dots +80 \text{ }^\circ\text{C}$

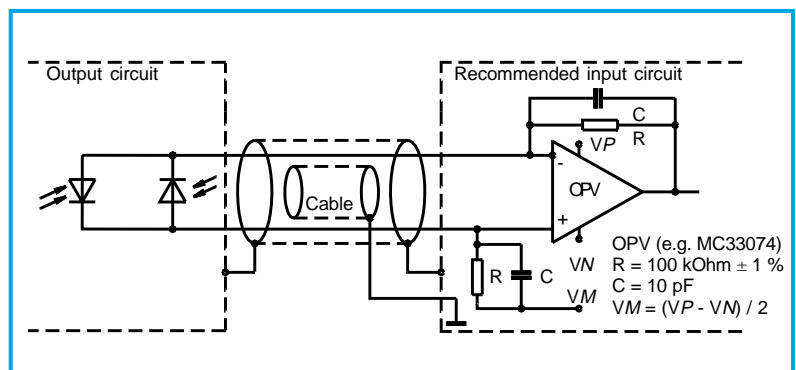

SI: Voltage interface 1 Vpp

Operating voltage: 5 V ± 5 % or 8 ... 30 V
 Current requirement: max. 180 mA
 Output signals: A+, A-, B+, B-, Z+, Z-
 Limit frequency (-3dB): max. 160 kHz

Signal level at a load of $Z_o = 120 \text{ Ohm}$: track signals:
 A, B $\sim 1 \text{ Vpp}$ (0,8 ... 1,2 Vpp)
 index signal (effective signal):
 Z $\sim 0,5 \text{ V}$ (0,2 ... 0,85 V)

Cable length: max. 150 m
 Operating temperature: $-10 \text{ }^\circ\text{C} \dots +80 \text{ }^\circ\text{C}$

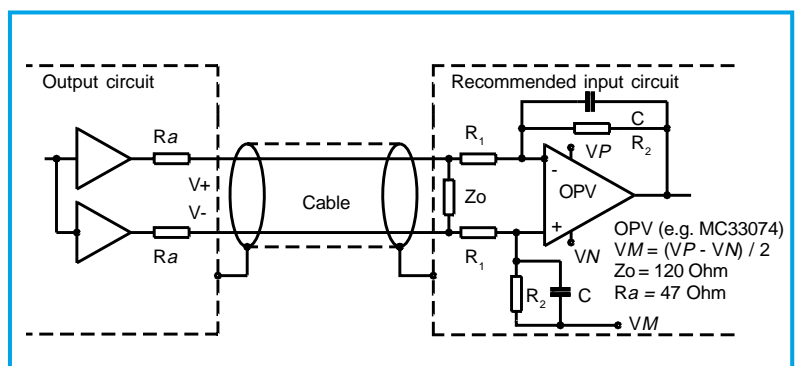

LTN Servotechnik GmbH

Ordering- information	G	71	X	X	XX XX	XXXX	-	X	X	X	-	XX			
	G	71	3	4	5.1 5.2	6	-	7	8	9	-	10			
G	Incremental Rotary Encoder														
71	Model series														
3	Mechanical specification														
	S = Type S						W = Typ W (Hollow shaft; mounting with torque coupling)								
	D = Type S + higher vibration capability														
	H = Type H														
	T = Type H + higher vibration capability						others upon request								
4	Shaft- or hollow shaft configuration														
	S = Standard 9,52 mm for G71S			T = 8 mm for G71S, G71W											
	S = Standard 12,692 mm for G71H			U = 10 mm for G71S, G71W											
	S = Standard 6 mm for G71W			V = 12 mm for G71W											
	D = 20 mm for G71W														
	others upon request														
5.1	Output circuit														
	LD = Line driver; RS422						TL = TTL compatible								
	PP = Push pull						OC = Open collector								
	KS = PP with short circuit protection						QI = Current interface 11µApp at 1 kOhm load								
	SI = Voltage interface 1 Vpp at 120 Ohm load														
5.2	Output channels														
	BI = channel A and B														
	IN = channel B only						others upon request								
6	Line counts														
	2	8	10	25	50	64	100	120	125	128	150	160	180	190	200
	240	250	254	256	300	350	360	380	400	500	512	560	600	604	625
	635	676	720	750	800	900	1000	1024	1125	1130	1152	1200	1250	1270	1440
	1500	1600	1800	2000	2048	2160	2164	2200	2400	2500	2540	2592	2670	3000	3092
	3142	3600	3927	4000	4096	4490	5000	5760	8192	9000	10000	others upon request			
7	Zero index Z														
	1 = Z „high“ if A „high“														
	5 = Z „high“ if A + B „high“						others upon request								
8	Flange														
	1 = square Flange						5 = round + sealed bearing								
	2 = Servo						6 = square + shaft seal								
	3 = round						7 = round + shaft seal								
	4 = square + sealed bearing						others upon request								
9	Connector or cable output														
	0 = connector axial						4 = cable radial with connector								
	1 = connector radial						5 = cable axial with connector								
	2 = cable axial (1m)						6 = leads axial								
	3 = cable radial (1m)						7 = leads radial								
	others upon request														
10	Supply voltage														
	05 = 5 Volts						24 = 8 ... 30 Volts								

LTN Servotechnik GmbH

Georg-Hardt-Straße 4

D-83624 Otterfing

Germany

Tel: +49 - 08024 - 60 80 - 0

Fax: +49 - 08024 - 60 80 - 100

E-Mail: LTN@LTN.de

Internet: www.LTN.de