

M-Sens 2

Online moisture measurement
for solids

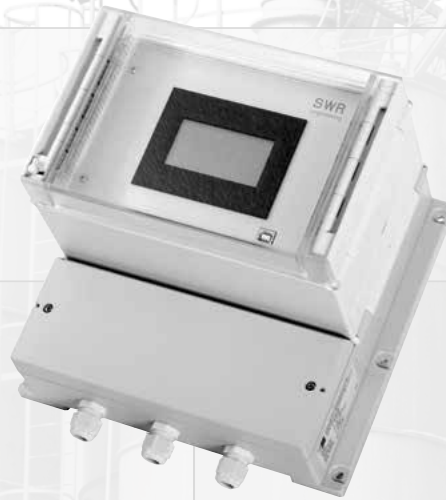
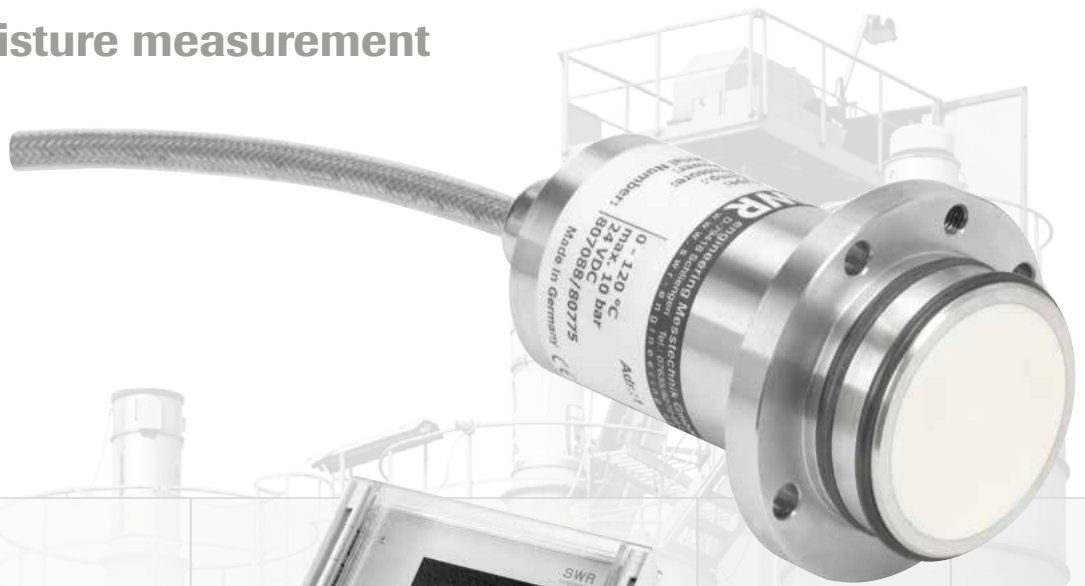

Using

M-Sens 2 is especially designed for continuous moisture measurement of solids during batching. This includes as well discontinuous measurement.

M-Sens 2 is used for online moisture measurement of:

- all types of dust, powder, granulates and other bulk solids
- in different mounting positions

M-Sens 2 is characterized by its uncomplicated installation as well as by its simple calibration. Due to its hygrostability and its resistance to mechanical shocks and abrasion the entire sensor is very fail-safe and allows a long service life. The sensor window is protected by a ceramic disc being very resilient with regard to abrasion and pressure.



Function

The M-Sens 2 sensor functionality is based on precise high-frequency measurement and direct digitalization of measured values, where from results a high resolution. As the materials surface and capillary moisture influences strongly its specific conductive capacity, the moisture can be measured exactly by a constant averaged bulk density. The calibration can be done very simply by the operator by pressing the button and entering the referenced moisture contents.

In this context it is convenient that measured value fluctuations by bulk density variations are balanced by an internal filter function. Additionally, measured value fluctuations by temperature variations are compensated automatically by the sensor.

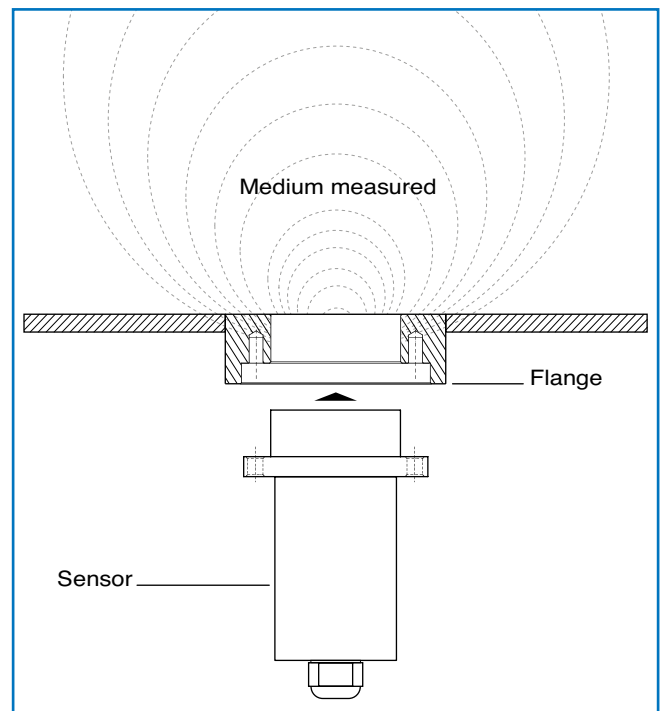

System

A complete measurement unit consists of the following components:

- welding flange
- 1 to 3 sensors, each with a 2 m connection cable
- MSE 300 transmitter in a wall-mounted housing or a DIN Rail format unit.
- C1-Box for the connection between sensor(s) and transmitter

The sensor probe is connected to the transmitter by a shielded, 4-wired cable. The maximum distance between the two components can be up to 300 m.

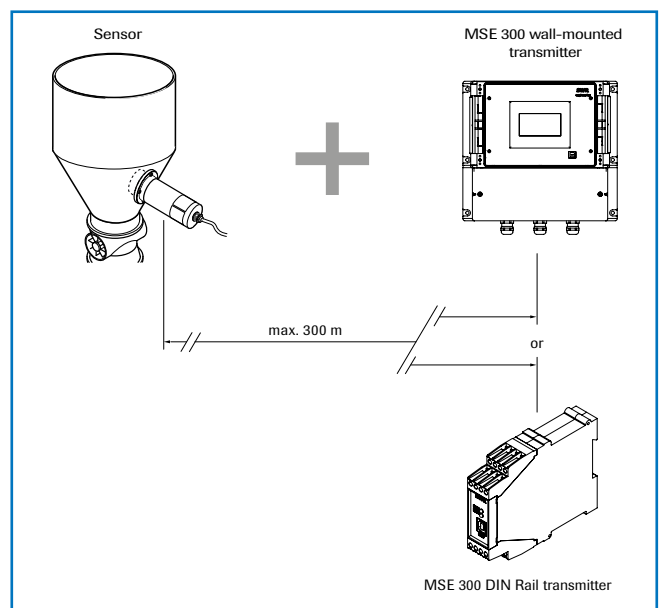

Using of more than 1 sensor

Due to the use of up to 3 sensors, connected to an MSE 300 transmitter, induced measurement inaccuracies, caused by the materials inhomogeneity, can be reduced.

At the same time there is reduction of the influence of bulk density variations which normally exist over the whole measurement zone.

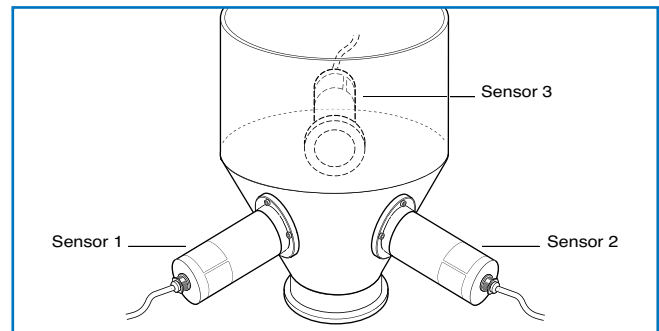

Applications - practical examples

▪ Installation in screw feeders

The installation of a moisture sensor in screw feeders proved to be very advantageous, since the material passes by the sensor window in even intervals and with relatively constant bulk density.

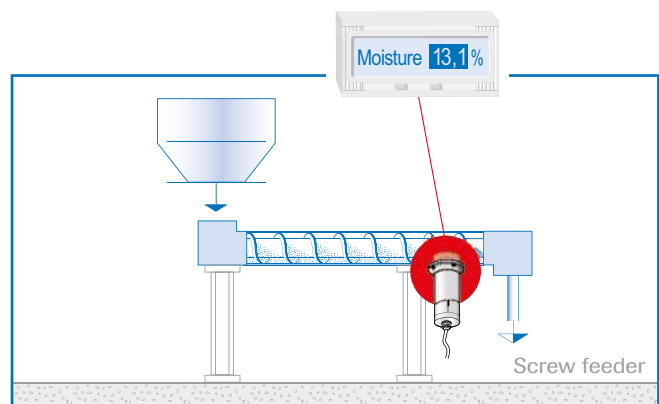

▪ Installation on conveyor belts

By means of the online moisture measurement of solids on a conveyor belt, the operator can react in due time if the material is too humid or too dry. In consequence, plugging of subsequent aggregates can be prevented.

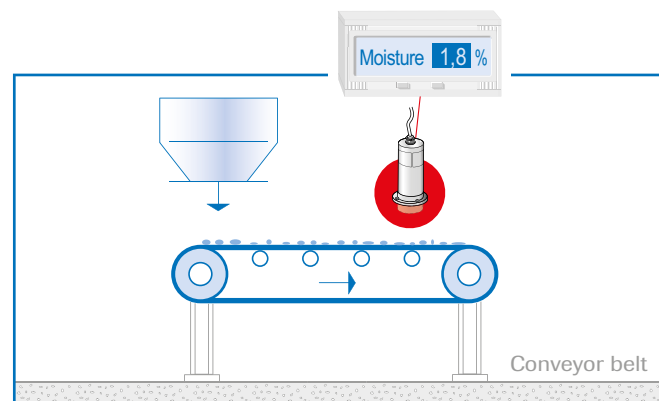

▪ Installation in bins

Another installation alternative is to mount a sensor at a bins outlet. Due to constant bulk density in case of a filled bin, the sensor finds an almost unchanging measuring field for monitoring the residual moisture. Thus, M-Sens 2 avoids that too damp material reaches the next production level or arrives into the loading.

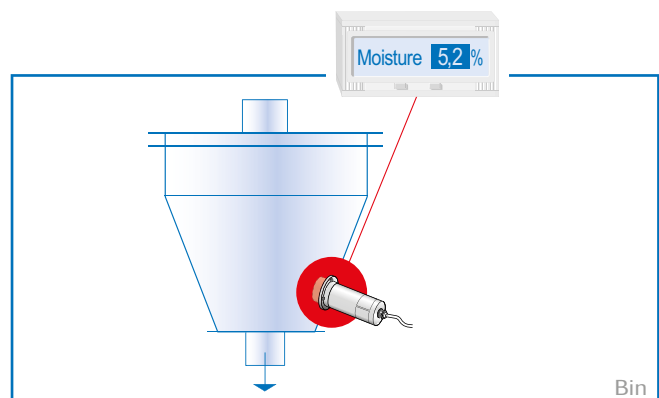

▪ **Control of dryer by means of an online moisture measurement**

After the material, lying on the belt, has passed through the dryer tunnel, it gets withdrawn from the hot air zone. At the end of the belt the dried material falls in a screw conveyor which transports it to the processing.

The operator queries the following points:
Has the material reached really the desired residual moisture value? That is, has he chosen the right cycle time and temperature?

M-Sens 2 provides accurate and reliable online moisture values for the process control, by which constant moisture in close tolerances of the output material can be met.

This process optimization enables the operator to manage high savings and quality improvements.

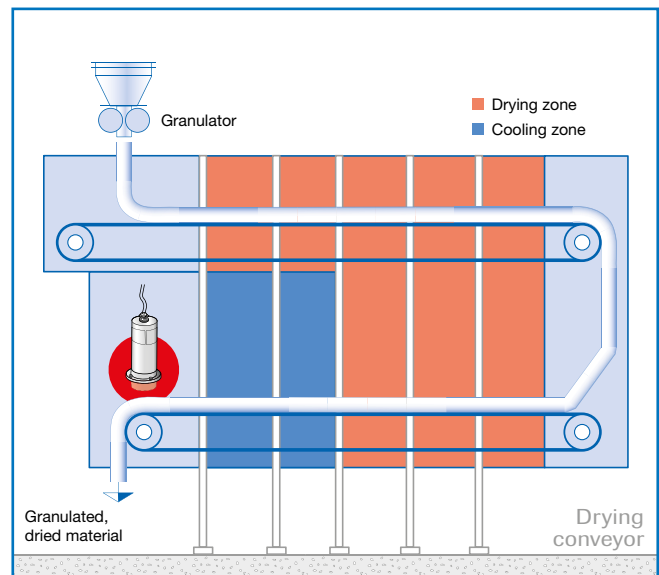

▪ **Moisture measurement in a mixer**

M-Sens 2 can be installed, even later on, in all types of mixers. The measuring values logging is done by within the moving material during the mixer procedure.

With the measured moisture value of the material in the dryer process parameters like detention time and dosage quantity can be controlled.

For this purpose M-Sens 2 is connected to a PLC or another process control system.

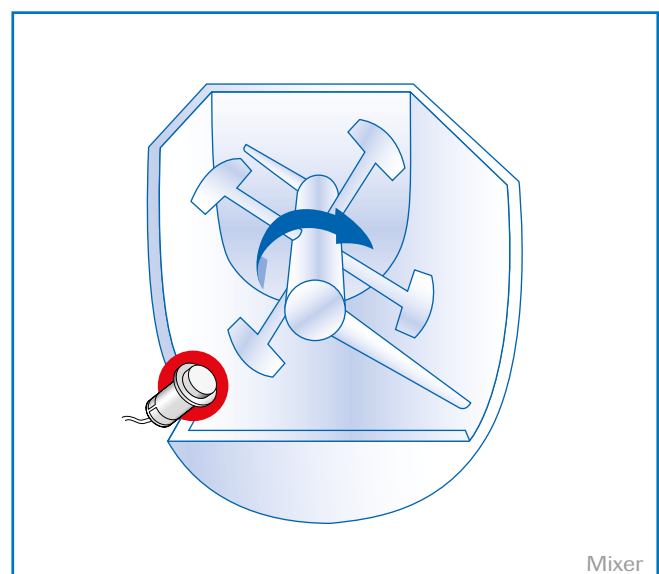

Uncomplicated commissioning

M-Sens 2 is calibrated by means of any number of reference points which are easy to enter. Even with only one reference point you get a sufficiently accurate display of the relative moisture.

The more reference points you enter, the more accurately the M-Sens 2 transmitter measures automatically the instantaneous relative moisture contents of your product.

1 Sampling

In order to calibrate M-Sens 2 start the reference point entry by the control panel of the transmitter. This reference point measurement by the M-Sens 2 sensor takes 1 min. During this time, when the material is moving, like e. g. on conveyor belts, take a sample out of the material flow after the sensor. Ideally you take several small samples from the material flow during this time. Is the point of your sampling located more distantly from the sensor (e. g. measurement in a silo or in a screw conveyor) then await the sampling as long as the material, which was under the sensor at the start, has arrived at this point. When the material is immovable, then await the end of the reference point measurement and take a sample under the M-Sens 2 sensor within the measurement zone.

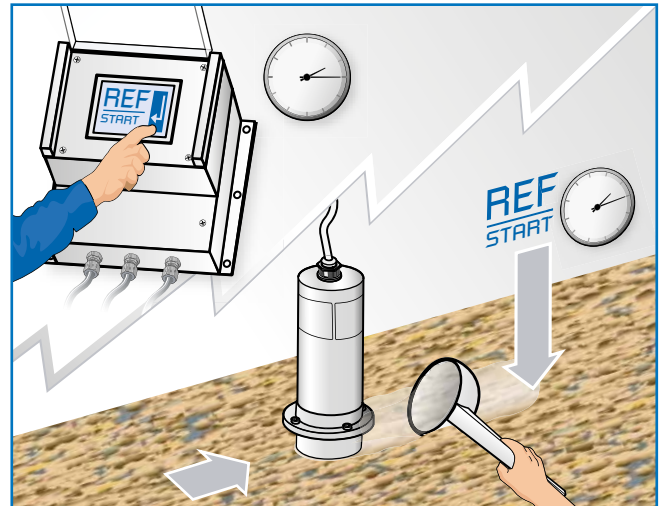

2 Laboratory test

Determine the relative moisture contents of the extracted sample by a laboratory test. The better the sample which is taken from the zone directly under the sensor during the reference point measurement, the more accurate is the calibration of M-Sens 2.

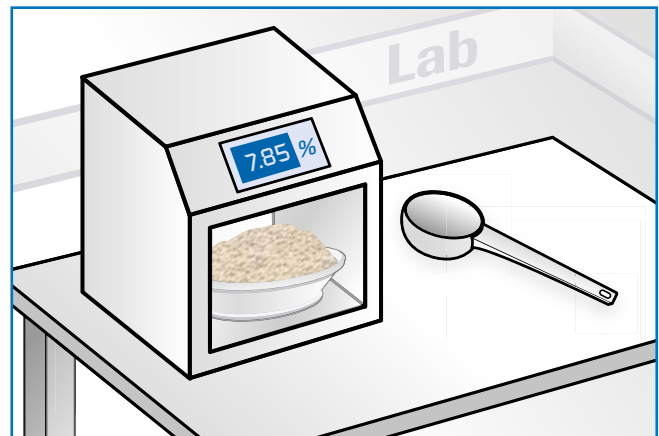

3 Entry of the moisture value

When the reference point measurement of 1 min is over enter the determined relative moisture value in the control panel of the transmitter.

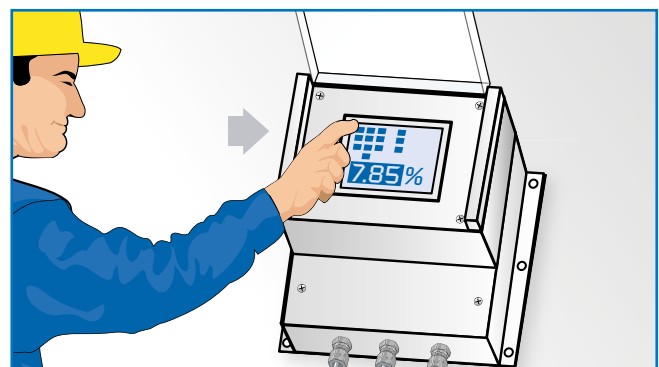

Technical data

Sensor	
Housing	Stainless steel 1.4571
Sensor surface	Ceramic
Ex-protection (optional)	Zone 20 (Dust), Zone 0 (Gas)
Protection category	IP 67 according to EN 60529
Material ambient temperature	0 ... +80 °C, optional 120 °C
Working pressure	Max. 10 bar
Power consumption	0.6 W
Response time	0.1 sec.
Weight	Approx. 1000 g
Measuring range	0 ... 65 % residual moisture (depending on material)
Accuracy	0.1 % absolutely in the calibrated measuring range
Connection cable	shielded cable 4-wired, 0.25 mm ²

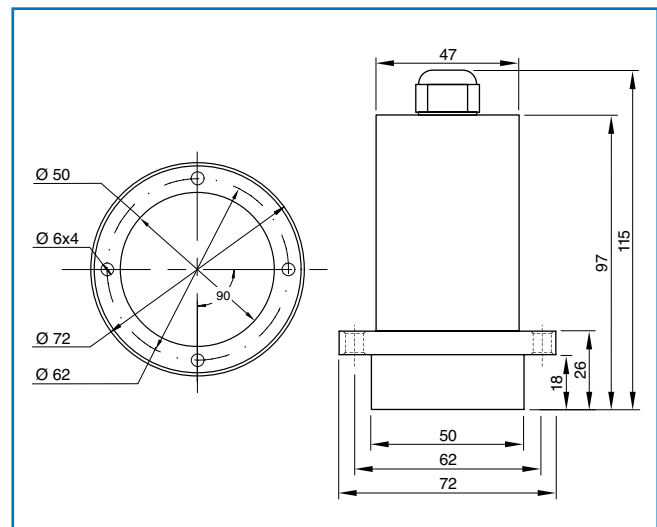

Transmitter (DIN Rail)	
Power supply	24 V DC ±10 %
Power consumption	20 W / 24 VA
Protection type	IP 40 to EN 60 529
Ambient operating temperature	-10 ... +45 °C
Dimensions	23 x 90 x 118 mm (W x H x D)
Weight	Approx. 172 g
DIN rail fastening	DIN 60715 TH35
Connection terminals cable cross-section	0.2-2.5 mm ² [AWG 24-14]
Current output	1 x 4 ... 20 mA (0 ... 20 mA), load < 500 Ω
Interface	RS 485 (ModBus RTU) / USB
Pulse output	Open collector - max. 30 V, 20 mA
Relay contact	Max. rated load: 250 V AC Max. peak current: 6 A Max. rated load 230 V AC: 250 VA Max. breaking capacity DC1: 3/110/220 V: 3/0.35/0.2 A Min. switching load: 500 mW (10 V / 5 mA)
Data backup	Flash memory

Transmitter (field housing)	
Power supply	110 / 230 V AC 50 Hz (optional 24 V DC)
Power consumption	20 W / 24 VA
Protection type	IP 65 to EN 60 529/10.91
Ambient operating temperature	-10 ... +45 °C
Dimensions	258 x 237 x 174 mm (W x H x D)
Weight	Approx. 2.5 kg
Cable screw connectors	3 x M16 (4,5 - 10 mm Ø)
Connection terminals cable cross-section	0.2-2.5 mm ² [AWG 24-14]
Current output	3 x 4 ... 20 mA (0 ... 20 mA), load < 500 Ω
Interface	RS 485 (ModBus RTU) / USB
Pulse output	Open collector - max. 30 V, 20 mA
Relay contact	Max. rated load: 250 V AC Max. peak current: 6 A Max. rated load 230 V AC: 250 VA Max. breaking capacity DC1: 3/110/220 V: 3/0.35/0.2 A Min. switching load: 500 mW (10 V / 5 mA)
Data backup	Flash memory

