

Manual Encoder ESM 80

Manual pulse generator

Resolution

Resolution (Pulses/Revolution):
100

Type explanation

ESM 80-4-0100-05-D-RK

Encoder type	Incremental
Flange diameter	ø 80 mm
Case diameter	ø 60 mm
Number of channels	2 = A + B 4 = AA + BB
Resolutions	100 = 100 Impulse pro Umdrehung
Supply voltage	05 = 5 VDC ±5% (Output D) 05 = 5 VDC ±10% (Output R)
Output driver	D-RS422 R
Position of clamps	RK = Terminal clamps at rear

Technical data

Mechanical data

Graduation	1 - 100
Rotational speed	? 600 min ⁻¹
Torque	3 ... 6 Ncm
shaft loading	20 N radial 10 N axial
Weight	0,4 kg

Environmental conditions

Vibration	150 ms ⁻² (55 Hz / 2h)
Shock	490 ms ⁻² (11 ms)
Operating temperature	-10 ... +60°C
Storage temperature	-30 ... +80°C
Atmospheric humidity	? 85% r.h.

Electrical data

Scanning type	Optical, without contact
Transmitter, infrared	LED
Receiver	Photo-Transistor
Supply voltage	V _{cc} = 5 VDC ±5%, Output D V _{cc} = 5 VDC ±10%, Output R
Power consumption	? 150 mA, output D ? 60 mA, output R
Signal level	High > V _{cc} - 1 V Low < 0,5 V (20 mA)
Load capacity of the outputs	20 mA

Output driver



Output channels / Output signals

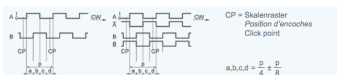

Outline drawing

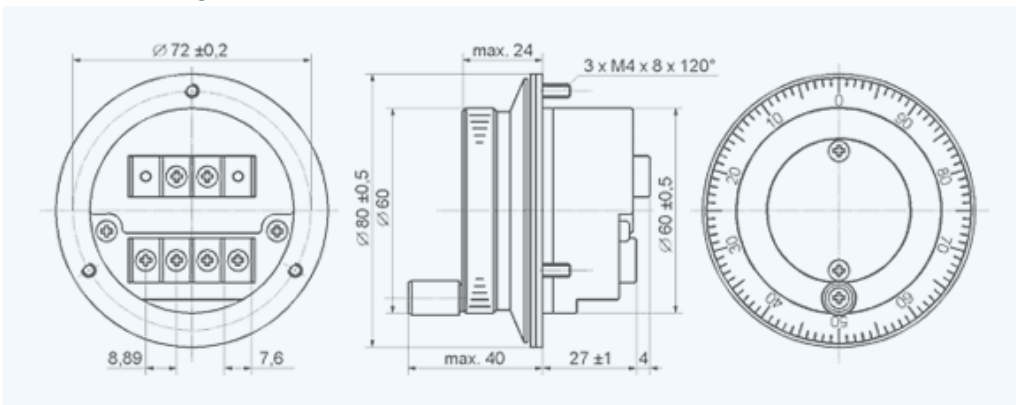

INDUcoder® · INDUcoder Messtechnik GmbH, Kaiserstraße 316, 47178 Duisburg, Deutschland
Tel: (0203) 57047-0, Fax: (0203) 57047-20, E-Mail: info@inducoder.de, Internet:
www.inducoder.de