

# MaxxFlow HTC

Flow measurement  
for dry bulk solids



## Use

The MaxxFlo HTC is specially developed for the flow measurement of dry bulk solids without any built-in in the flow. Due to its independence from angle of the pipework and its low installation height, the MaxxFlo HTC is especially suitable in situation in which it was previously only possible to use complicated or expensive mechanical solutions, e. g. impact plates or measuring chutes. The installation of the MaxxFlo HTC takes place independently of the direction of the line (vertical/inclined), but always after mechanical conveyor elements, e. g. rotary feeder, screw conveyors, air slides or chain conveyors.

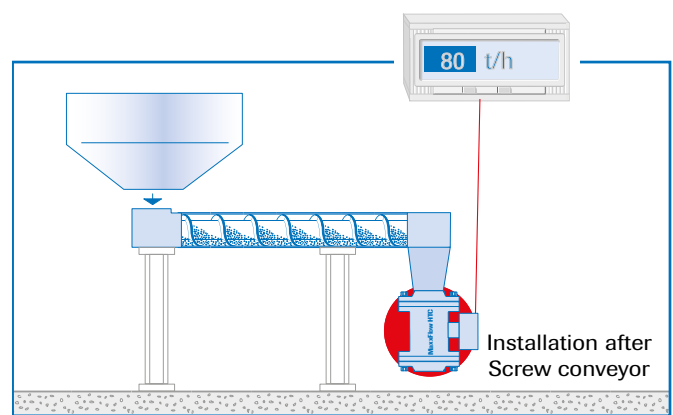
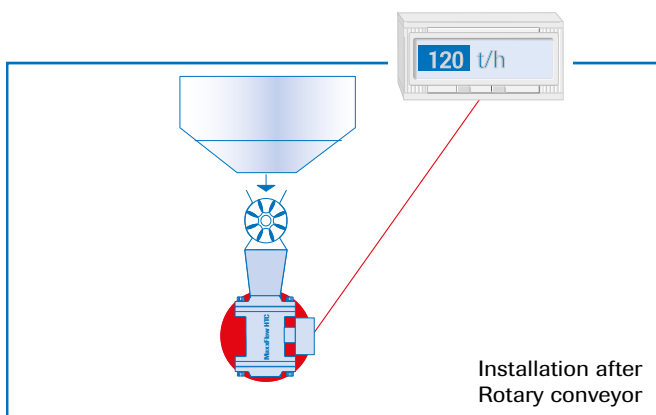

## Function

After the conveyor, the material to be measured falls or slides through an inlet path and runs through the sensor. During the throughput, the MaxxFlo HTC records the material density and speed. Since the material falls from a constant height after emerging from the conveyor element, the speed of the product stream is accelerated, but is constant at the installation position of the sensor. Due to this constant speed, the speed measurement does not need to be activated in every case, but can be calculated as a constant depending on the height of the fall. The mass flow is determined as follows:

$$Q \text{ (kg/s)} = K \text{ (kg/m}^3\text{)} \times v \text{ (m/s)} \times A \text{ (m}^2\text{)}$$

Through the input coupling of a high-frequency, electromagnetic alternating field, a homogenous measuring field is generated in the measuring tube.

The measuring tube (interior tube of the sensor) consists of wear-resistant  $\text{Al}_2\text{O}_3$  ceramics. Dry bulk solids inside the measuring field reduce the amplitude of the alternating field. This leads to a measuring signal, behaves with a system accuracy of 0.04 %, proportional to the concentration of the bulk solids in the sensor ( $\text{kg} / \text{m}^3$ ).

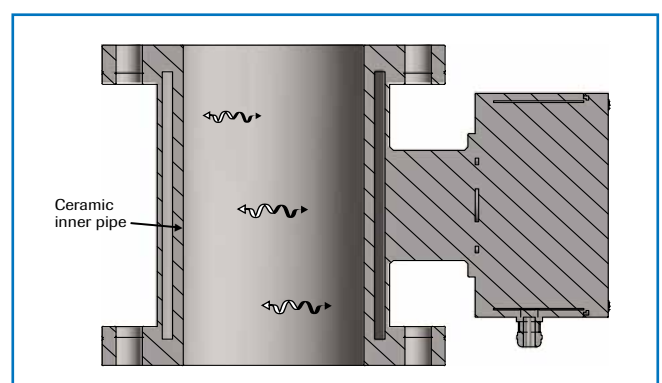
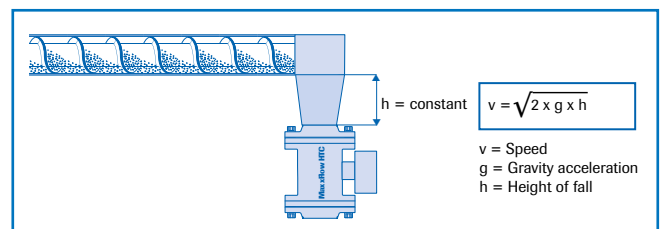

If the material speed varies, for example due to a change in initial speed, then this can also be measured.

This takes place through a runtime measurement with the help of two additional electrodes behind the interior ceramics tube.

## Calibration

The recording of the speed is in every case independent of the type of the dry bulk solids that are to be measured, since they can either be calculated or based on a runtime measurement.

Thus the speed measurement requires no calibration.

This makes a new and simple type of calibration possible: A material sample (approx. 10 liter = sensor volume) can be poured into the sensor via a filling nozzle in the inlet path above the sensor.

There is a knife-gate below the sensor that is closed for the calibration. If the sensor is completely full, then the measured density value must correspond to the bulk density of the material.

This bulk density (set point) can simply be determined as  $\text{kg/m}^3$  weight and entered in the evaluation unit (full calibration). Even with large product flows, the measurement is completely calibrated with a material sample of only about 10 liter.

Material drop-tests using calibration points during a running process are thus a thing of the past.

The handling of several tons of material as a reference therefore is no longer necessary.

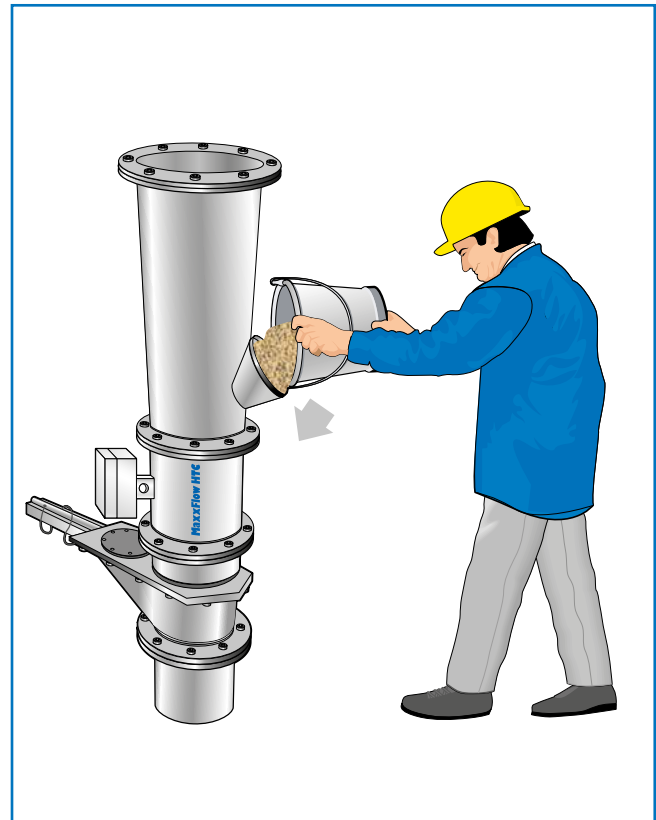

## System

A complete measuring station consists of these components:

- Measuring feeder for installation in the conveyor line
- Transmitter MSE 300

The measuring feeder is available in sizes DN 70 mm, DN 100 mm, DN 150 mm and DN 200 mm.

With the design in DN 70 mm, the connection flange could be freely selected.

The transmitter is connected to the sensor using 4-wired, shielded cable.

The maximum distance between measuring feeder and transmitter is 300 m.

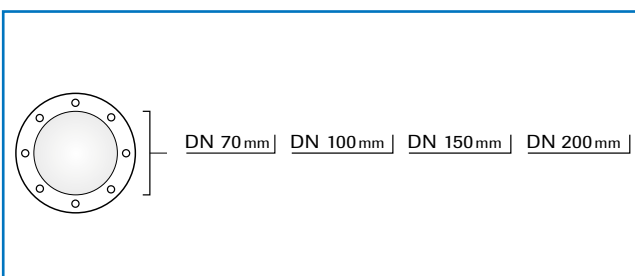

## Configuration

For the configuration of the sensors, the knowledge of the maximum volume flow is fundamentally important in order to configure the measuring point in such a way that the dry bulk solids can flow through the sensor unhindered and the product flow is not influenced.

The diagrams in figure 1 and 2 shows the maximum conveyable volume depending on material speed.

The sensor cross-section in all cases is filled to 50 %.

### Example:

If the max. mass flow amounts to 80 t/h, and if the material has a bulk density of 0.8 t/m<sup>3</sup>, then the maximum volume flow amounts to 100 m<sup>3</sup>/h.

When using a MaxxFlo HTC DN 150 mm, a speed of approx. 3 m/s would be necessary.

When using a MaxxFlo HTC DN 200 mm, a speed of approx. 1.7 m/s will be required.

Figure 3 shows that for these speeds to be reached, an inlet path of 0.5 respectively 0.15 m will be necessary between the conveyor and the sensor.

### Turndown and measuring range

Which sensor type is being used depends on the available standing installation height and the turndown or the desired measuring range.

The sensor itself has an installation height of 216 mm (DN 70), 220 mm (DN 100 mm), 290 mm (DN 150 mm) or 310 mm (DN 200 mm).

To equip the measuring point from the above example with a DN 150 mm sensor, an installation height of 500 mm + 290 mm = 790 mm would be necessary.

The turndown, i.e. the ratio between the end and the beginning of the measuring range, amounts to 1:5 for all MaxxFlo HTC sensors.

With regard to the example provided, it is possible to measure with a MaxxFlo HTC DN 150 mm between 20 m<sup>3</sup>/h and 100 m<sup>3</sup>/h.

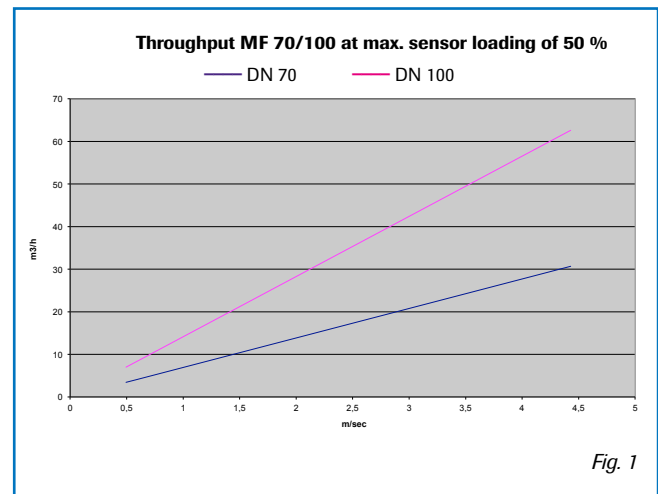

Fig. 1

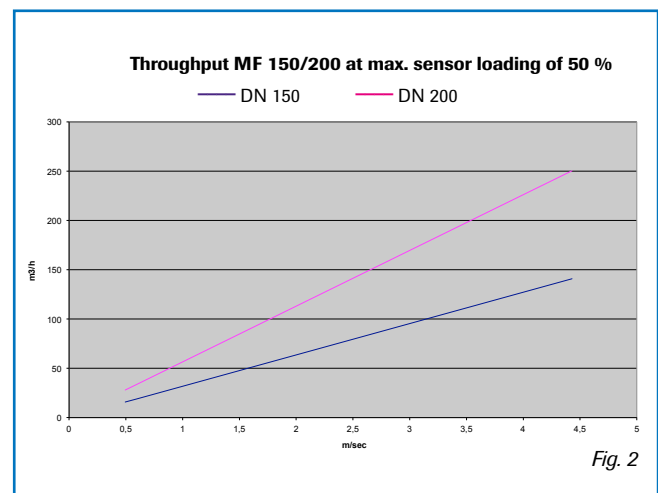

Fig. 2

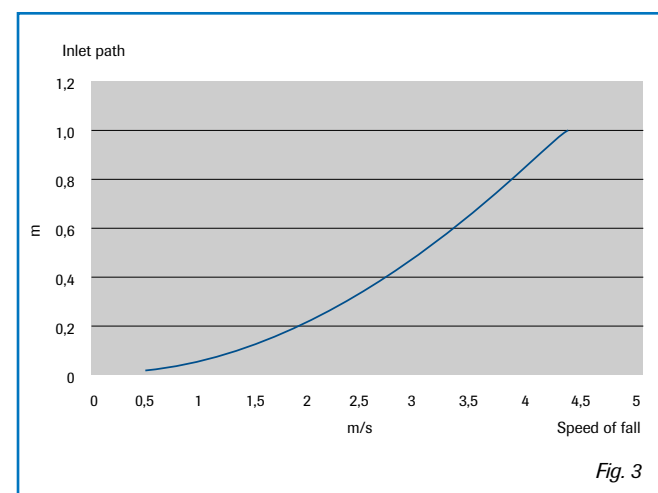

Fig. 3

A MaxxFlow HTC DN 200 mm can also be used for this measuring task. Care must be taken that the angle for the contractions of the inlet path at a height of 0.15 m does not become too flat. The angle  $\alpha$  (see figure 4) must be at least  $60^\circ$  in order to guarantee a flawless product flow. If the inlet path (height of fall) must be enlarged to maintain the demand after an angle  $> 60^\circ$ , then it must be noted that the lower limit of the measuring range moves upward.

If for example an inlet path of 0.3 m would become necessary, then the speed would be approx. 2.5 m/s and thus the maximum volume for a MaxxFlow HTC DN 200 mm 150 m<sup>3</sup>/h.

With a turndown of 1:5, the lower measuring range limit would then be 30 m<sup>3</sup>/h.

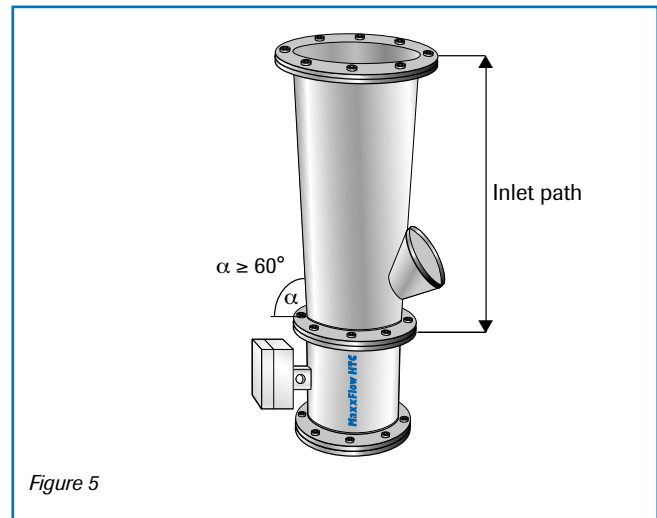
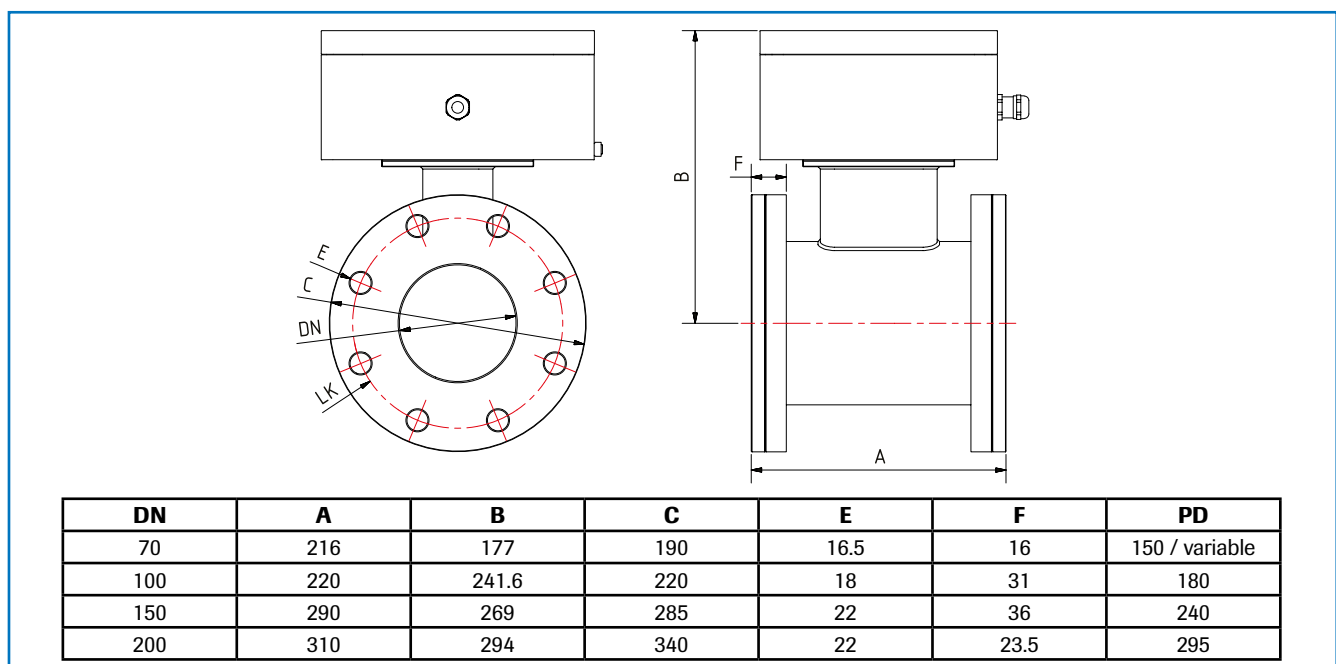

Figure 5

## Advantages

- installation free of obstacles in the cross-section, therefore no dead spots
- independent of the arrangement of the line (vertical or inclined)
- simple refitting
- dust proof
- zero-contact measuring procedure (no mechanics)
- maximum material temperature 120 °C
- pressure-resistant up to 10 bar on request
- abrasion-resistant ceramic inner pipe
- maintenance free
- system accuracy of 0.04 %

## Dimensions



## Technical data

Sensor	
Housing	Steel St 52, powder-coated (optional stainless steel 1.4571) NW 70/100/150/200 mm, Flange according EN 1092-1 / PN10 DN 70: variable
Inner pipe	Al <sub>2</sub> O <sub>3</sub> -Ceramic
Protection category	IP 65, ATEX: Cat. 3D
Operating temperature	Sensor pipe: - 20 ... + 120 °C Sensor electronic: 0 ... + 60 °C

Max. working pressure	1 bar, optional 10 bar
Working frequency	88 kHz
Transmitting power	Max. 2 mW
Weight	Depend on diameter
Accuracy	± 1 ... 3 % (based on end of measuring range and calibrated material)
System accuracy	± 0.04 %

Transmitter (DIN Rail)	
Power supply	24 V DC ±10 %
Power consumption	20 W / 24 VA
Protection type	IP 40 to EN 60 529
Ambient operating temperature	-10 ... +45 °C
Dimensions	23 x 90 x 118 mm (W x H x D)
Weight	Approx. 172 g
DIN rail fastening	DIN 60715 TH35
Connection terminals cable cross-section	0.2-2.5 mm <sup>2</sup> [AWG 24-14]
Current output	1 x 4 ... 20 mA (0 ... 20 mA), load < 500 Ω
Interface	ModBus RTU (RS 485) / USB
Pulse output	Open collector - max. 30 V, 20 mA
Relay contact	Max. rated load: 250 V AC Max. peak current: 6 A Max. rated load 230 V AC: 250 VA Max. breaking capacity DC1: 3/110/220 V: 3/0.35/0.2 A Min. switching load: 500 mW (10 V / 5 mA)
Data backup	Flash memory

Transmitter (field housing)	
Power supply	110 / 230 V AC 50 Hz (optional 24 V DC)
Power consumption	20 W / 24 VA
Protection type	IP 65 to EN 60 529/10.91
Ambient operating temperature	-10 ... +45 °C
Dimensions	258 x 237 x 174 mm (W x H x D)
Weight	Approx. 2.5 kg
Interface	RS 485 (ModBus RTU) / USB
Cable screw connectors	3 x M20 (4,5 - 13 mm Ø)
Connection terminals cable cross-section	0.2-2.5 mm <sup>2</sup> [AWG 24-14]
Current output	3 x 4 ... 20 mA (0 ... 20 mA), load < 500 Ω
Pulse output	Open collector - max. 30 V, 20 mA
Relay contact	Max. rated load: 250 V AC Max. peak current: 6 A Max. rated load 230 V AC: 250 VA Max. breaking capacity DC1: 3/110/220 V: 3/0.35/0.2 A Min. switching load: 500 mW (10 V / 5 mA)
Data backup	Flash memory

