

## Power & Signal



Circular



Rectangular



Board Level



Modular



Distribution Solutions



Attachment Systems



Heavy Duty



Plastic

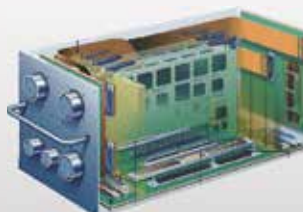

Custom Solutions



Cable Assemblies



Amphenol's founder Arthur J. Schmitt discovered that insulating plastic could be more effectively used to produce radio tube sockets than brittle Bakelite  
 \*Amphenol is born (1932).

# Circular Connectors

- MIL-DTL-5015
  - MIL-DTL-26482
  - MIL-DTL-38999
  - MIL-DTL-26500
  - MIL-DTL-83723
  - MIL-DTL-22992
  - MIL-DTL-55181
- MIL-DTL-55116
  - VG Series Connectors
  - DIGITAL NETWORK Solutions
  - Rack & Panel RNJ
  - HIGH SPEED Solutions
  - POWER Connectors
- MICROMINIATURE Connectors
  - FILTER Connectors
  - HERMETIC Connectors
  - EX PROOF Solutions
  - Fiber Optic Solutions
  - Backshells

Through participation in the war effort Amphenol establishes itself as a premier technology driven interconnect and cable company. The 5015 AN series connector is born and is soon known as the "Amphenol Connector" by military maintenance crews. The B-29 Super Fortress contains over 1600 Amphenol connectors. Amphenol's Sidney, NY facility is designated a site of national importance and is defended from air strikes.

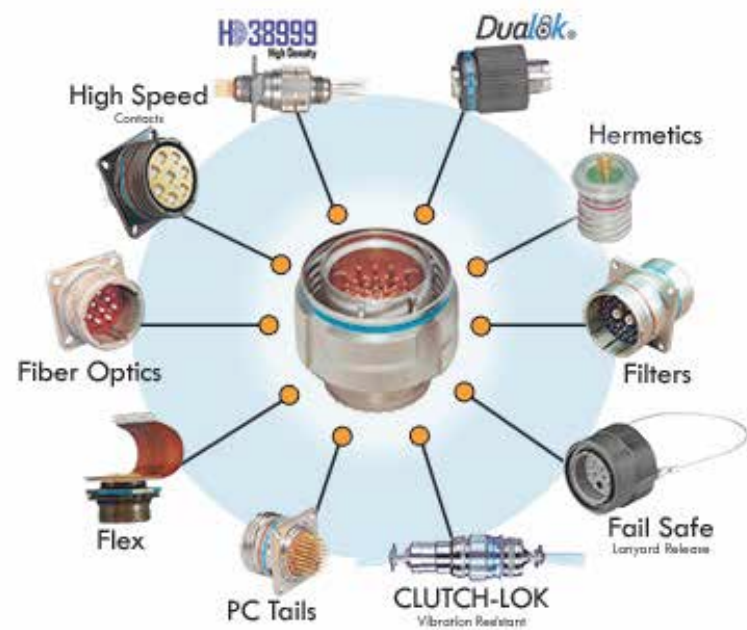



**MIL-DTL-5015**

Amphenol MS and 97 series are two series of thread-coupled connectors designed to meet the operating requirements of MIL-C-5015. Available in a variety of styles and classes, these connectors are primarily used in a range of military and industrial applications where specific degrees of environmental protection are required.

Amphenol Aerospace's MIL-DTL-5015 with crimp rear release contacts provides an alternative to the older MIL-C-5015 solder type. It bridges the gap between an old connector standard and the high performance needs of current technologies.



**MIL-DTL-26482**

Amphenol MIL-C-26482, Series 1 Connectors are miniature circular connectors with three-point bayonet-coupling and five-key polarization, solder type, British standard 62GB, Amphenol form PT, Amphenol low cost form 62IN, these connectors are widely used in applications calling for quick disconnect connectors.

Amphenol MIL-C-26482, Series 2 Connectors are bayonet-coupling type, and they feature crimp contacts that are rear insert able and rear releasable. They can be ordered through Amphenol, by military or equivalent proprietary part numbers.



**MIL-DTL-38999**

MIL-DTL-38999 Series III Connectors offer the highest performance capabilities for both general duty and severe environment applications, both in original MIL specified and Amphenol coding TV/CTV series with threaded coupling, scoop-proof features. Al alloy, composite, stainless steel, marine bronze, durmalon and RoHS versions available.

MIL-DTL-38999 Series I LJT - Series II JT were developed to meet the needs of the aerospace industry, and provided the impetus for development of the MIL-C-38999 specifications. Dependable 5 key/keyway polarization with bayonet lock coupling is incorporated to aid and assure positive mating.

SJT connectors combine unique design features of the scoop-proof LJT series within standard mounting dimensions of JT types. Available in a wide range of shell sizes, finishes, insert arrangements and accessories.



**MIL-DTL-26500**

High quality and dependability are the earned reputations of the Amphenol®/Pyle® Series of connectors designed to meet the specification requirements of MIL-DTL-26500. Serving such diverse fields as avionics, missile systems, aircraft general-purpose applications, aircraft engines and firewalls.



### MIL-DTL-83723

Matrix MIL-DTL-83723 series provides many choices within the range of a medium sized, environmentally resistant circular connector. With three coupling style choices- bayonet, threaded and quick-disconnect - the versatility of this family makes it increasingly popular for panel mount, box mount and line-to-line applications in aircraft. For general duty environmentally resistant requirements, this family of connectors provides a wide range of interconnection solutions.

The Amphenol/Pyle® MIL-DTL-83723\*, Series III Connectors were developed for the higher operating temperatures inherent in today's high performance aircraft and aircraft engines.



### MIL-DTL-55181

Amphenol MW series power connectors are MIL Qualified & listed in QPL & meets the requirement of MIL-DTL-55116.

MW series power connectors are with center lock coupling screw, waterproof & polarized. Connectors used for interconnection of power & control circuit electric equipment specially in U.S. Army Communication System.

These connectors are designed to withstand high shock & vibrations ensured with center locking screw mechanism.



### MIL-DTL-22992

The Amphenol Class "L" 22992 heavy duty connectors are the largest size cylindricals. They are available only in the specific configurations prescribed by MIL-DTL-22992 for either military or industrial applications. This rigid configuration control assures correct interconnection of electrical circuits for maximum safety and reliability.



### MIL-DTL-55116

These connectors are water resistant, polarized, five and six contact electrical connectors for use in low voltage audio frequency circuits and applications. They employ three-point bayonet coupling for quick disconnect and self - wipe contact. Although designed for use in communications equipment, these versatile connectors, have been successfully adapted for use in numerous industrial, scientific and educational applications.

These connectors are qualified to MIL-DTL-55116, Amphenol form 164 Series.



### VG SERIES CONNECTORS

VG95328 connectors are qualified to the American MIL-DTL-26482 series I standard in crimp, solder, wire wrap, PCB versions, with different sealing levels which are well known in aeronautics, military and industrial applications.

VG95234 connectors are qualified to MIL-C-5015 with reverse bayonet coupling.

VG95319-1006, VG95319-1007, VG95319-1008 connectors are qualified to MIL-DTL-38999 series III with Metal Shells- Aluminum, Stainless Steel, Class K Firewall.

The VG95319-1011 backshells provide a range of popular backshell styles in straight or 90 degree form, to accommodate heat shrink boots, EMC screen termination with band and cone termination for EMC screening braid or non-metallic cable protection braid.



### HERMETIC CONNECTORS

Amphenol offers superior electrical performance plus the rugged design of a glass-sealed or epoxy-sealed connector. Amphenol glass-sealed hermetic connectors are available in a wide variety of MIL-Spec and custom configurations. Amphenol epoxy-sealed connectors are a lightweight alternative to glass-sealed hermetic connectors.



### DIGITAL NETWORK SOLUTIONS

Amphenol provides Ethernet Network Solutions for use in harsh environments, where reliability and resistance to outside influences, such as temperature, shock, vibration, water, dust, etc. are paramount.

Our rugged and durable solutions give you the insurance of a continuous and secure data transmission between all your communication devices in the harshest environments. All Amphenol's RJ-Switch products are tested and certified by an external accredited laboratory.

Amphenol Ethernet switches feature 8 to 28 ports with rugged connectors to interconnect terminal devices within armored vehicles, such as rugged PCs, screens, radios, with high data transmission (up to 10 Gbps). Designed to operate in armored vehicles and other harsh environments, our Ethernet switches feature mechanical packaging enhancements designed for MIL-STD-810F airborne and ground environmental compliance and high reliability.

The units have been especially hardened to improve waterproofness, impact, and shock/vibration protection, as well as eliminate all moving parts through passive cooling, and interface through MIL-D-38999 circular or RJ Field connectors.



### RACK & PANEL RNJ

Rack & panel connection Floating system which provides correction and adjustment to misalignment problem between plug and receptacle during mating. Derived from MIL STD 38999. Large number of inserts available to accommodate signal and power contacts: 7 shell sizes and up to 128 contacts. Version for power application: 1 contact of 230A or 4 contacts 100A.



### FILTER CONNECTORS

Amphenol® EMI/EMP Protection Connectors offer the versatility of standard connectors with EMI/EMP protection for sensitive circuits. Internal housing of the EMI/EMP devices eliminates costly and bulky exterior discrete protection devices. Virtually all major MIL-Spec circulars can be incorporated with filter devices:

- MIL-DTL-38999
- MIL-DTL-5015
- MIL-DTL-26482
- MIL-DTL-27599
- MIL-DTL-83723
- MIL-DTL-26500



### POWER CONNECTORS

Amphenol offers a wide range of cylindrical products for use in high power, high amperage applications. From ground systems and shipboard power to military vehicles and heavy equipment, Amphenol has the connector you need to power your system. In addition, we'll continue to design new connectors to meet the latest power needs. All major circulars can be incorporated with power RADSOK contact technology.

- MIL-DTL-38999
- MIL-DTL-5015
- MIL-DTL-26482
- MIL-DTL-22992
- GT Power
- 97 / 97B Power
- VG Power
- EV Power



### HIGH SPEED SOLUTIONS

The High Speed Solutions group is one of the fastest growing and most technologically advanced groups within Amphenol. Everyday, the High Speed Solutions team is developing custom connector and cable solutions for High Speed Copper, Fiber Optic, and Integrated applications. As a basic business philosophy, the team is dedicated to concentrating on those advanced and challenging market segments that demand an extraordinary level of supplier support and reaction. Amphenol High Speed Guide is based on the following Protocol Guide:

- Ethernet 10Base-T
- Gigabit Ethernet 1000Base-T
- 10 Gigabit Ethernet 10GBase-T
- USB 2.0
- USB 3.0
- DVI
- Display Port 1.0
- Display Port 1.2
- SATA 1.0
- SATA 2.0
- SATA 3.0
- HDMI

Please see [“Amphenol RF Solutions”](#) and [“Amphenol Fiber Optics”](#) catalogue for detailed information.





### MICROMINIATURE CONNECTORS

Amphenol 2M Micro-Miniature Connector Series product line is designed for interconnect applications requiring high performance and reduced size and weight. This smaller, high density, lightweight connector far exceeds the competition in quality and performance levels. The 2M Series is a superior and versatile connector designed and tested to mil-spec standards, comparable to MIL-DTL-38999. 2M is intermateable with Glenair's Mighty Mouse the test results are available in the Technical Documents area.



Amphenol Terrapin is a miniature series of circular push-pull connectors. Within a rugged shell design Terrapin offers superior EMC performance and is sealed to IP68. Resilient in severe battlefield situations the RoHS compliant black-silver plating is both low-lustre and corrosion resistant. Featuring an optional locking mechanism, multiple shell sizes with up to 37 contacts and suitability for over-moulding, Terrapin is the preferred choice for miniature connectors in military and other harsh environment applications.



### BACKSHELLS

Complete range of backshells for all circular connectors is now available from Amphenol now. These backshells are QPL certified to AS85049 standard and any variants of the same could be supported in short lead-time. The full technical details are available from the exclusive website [www.backshellworld.com](http://www.backshellworld.com).

In ground and naval application the robustness and the environmental sealing may be more important, where as weight may be prime consideration for space and Aerospace application. Amphenol backshells are available in different types for variety of applications.

- Non-Environmental Backshell
- Environmental Backshell
- Non Environmental EMI/RFI Backshell
- Environmental EMI / RFI Backshell
- Shrink Boot Adapter
- Shrink Boot Nut
- Band Lock Adaptor
- Crimp Adaptor/Ring Backshell
- Quick Clamp
- Strain Relief
- Grommet Nut Backshell



With the widest range of circular connectors conforming to most Military (MIL) specifications in the product portfolio, Amphenol retains its undisputed leadership in these categories of products. **Backshell** is an integral part of any Circular connector when it comes to reliable cable connections. It is only logical for Amphenol to offer full range of **Backshells** as it creates newer values for our esteemed customers.





Intended for harsh environment applications and used extensively in soldier communications, Amphenol Terrapin is a miniature series of circular push-pull connectors. Within a rugged shell design Terrapin offers superior EMC performance and high environmental sealing to IP68. Resilient in severe battlefield situations the RoHS compliant black-silver plating is both low-lustre and corrosion resistant. Featuring an optional locking mechanism, multiple shell sizes with up to 37 contacts and suitability for overmoulding, Terrapin is the preferred choice for miniature connectors in military and other harsh environment applications.

# TERRAPIN

## Miniature Rugged Connector Series

aluminium terrapin

terrappin ethernet

terrappin micro USB

terrappin filtered

  
**-50%**



Amphenol





### EX-PROOF (ATEX) SOLUTIONS

Certain hazardous environments, including those found in oil & gas exploration, petrochemical plants, fuel storage sites, and pharmaceutical and food manufacturing, require explosion-proof or ATEX-rated connectors. ATEX connector lines Amphe-EX and Star-Line EX, which are suitable for Zone 1 and Zone 2 hazardous areas, as well as provides the cable assembly. ATEX connector lines Amphe-EX, Star-Line EX, RJ Field, which are suitable for Zone 1 and Zone 2 hazardous areas, as well as provides the cable assembly.

Star-Line Series “ZP/ZR” connectors are heavy duty environmentally sealed plugs and receptacles and have been successfully used in all types of Industrial and Aerospace applications. These compact environmental connectors have provided outstanding performance in complex ground support cable networks, automatic and process control systems and instrumentation systems. These connectors combine electrical and mechanical capabilities that equal or exceed the performance parameters established by the Military Specification MIL-5015.

The new Amphe-EX™ is complimentary to Amphenol’s industry-proven Star-Line EX™ and has miniature, explosion-proof threaded connector specifically designed to allow a signal to pass through Zone rated areas using coax, fiber optic cables, or standard copper.

Amphenol offers RJ 45 and USB insert options available in rugged form both for Zone-1 and Zone-2.

In its ATEX certified facilities Amphenol can supply a complete cable assembly solution.



### FIBER OPTIC SOLUTIONS

Amphenol offers a wide range of fiber optic interconnect solutions for use in the harsh environments found in military and aerospace applications. From multiple fiber optic termini options to connectors to custom cable assemblies, Amphenol can provide solutions for virtually any fiber optics need.



Amphenol has established the rugged and reliable MIL-DTL-38999 as a common connector shell platform that houses a wide variety of fiber optic termini including MIL-PRF-29504 commercial equivalent, HDF20, ARINC 801 and MT ferrules.

Please see “[Amphenol Fiber Optics](#)” catalogue for detailed information.

# Amphenol

Türkiye&MiddleEast



## OUR SMALLEST CONNECTORS FOR YOUR MOST IMPORTANT JOBS



- + 52% smaller than MIL-DTL-38999
- + 71% in weight savings compared to MIL-DTL-38999
- + Designed for use in the harshest environments

The 2M Micro-Miniature Connector Series product line is designed for interconnect applications requiring high performance and reduced size and weight. This smaller, high density, lightweight connector far exceeds the competition in quality and performance levels. The 2M Series is a superior and versatile connector designed and tested to mil-spec standards, comparable to MIL-DTL-38999.

**2M**  
Micro-Miniature



## Rectangular Connectors

- ARINC 404
- ARINC 600
- R39 - Rectangular 38999
- R27 - MIL-DTL-835527
- R58 - MIL-DTL-83733 & JN1122
- Brush Rack & Panel Connectors
- RFM SERIES - Modular Floating Racks
- MIL-DTL-24308 D-SUB
- M83513 - MICRO-D
- MMA - Blind Mate
- ASR Connectors
- EN3545 / 1900 Connectors

### Advantages of Filter Connectors:

The integration of the filter elements into the connector, rather than a board level solution, results in many advantages to the user:

- ✓ Reduction in space and weight
- ✓ Reduction in inspection and assembly labour
- ✓ Improved high frequency EMI performance by elimination of parasitic effects associated with board level filters
- ✓ Superior shielding effectiveness

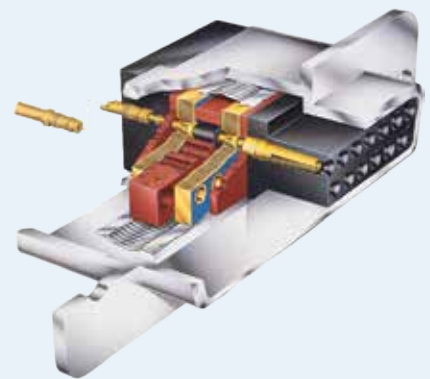



### ARINC 404

Amphenol's "AR" Series, ARINC rack and panel ARINC 404 connectors meet or exceed MIL-C-81659 and ARINC Specification 404. The "AR" Series is a multi-purpose connector used in aerospace, military and computer periphery applications.

These connectors are available in five shell styles with up to four insert cavities. Inserts in this product line accommodate signal and power contacts in sizes 12, 16, 20 and 22. Coaxial contacts are available in sizes 5 and 9. Insert arrangements are available utilizing a single type contact or a combination of standard and coaxial contacts.

Non-environmental and environmentally sealed connectors are offered. The environmental sealing is accomplished by wire sealing grommets and interfacial seals. Application specific designs, including transient protection, are available from Amphenol.



### ASR Connectors

The ASR connector is a compact and easy to use interconnect where shielding, sealing, and space / weight-saving are prime requirements. ASR connectors use MIL-C-39029 contacts, feature a snap-locking mechanism and are available in both male and female versions, as well as with PCB or crimp contacts. Fully Reach / RoHS compliant and conform to ABD0031 and FAR 25853 (Fire, Smoke and Toxicity), the ASR series is perfectly suited for in-seat systems, as well as cabin service systems and in-flight entertainment systems.



### ARINC 600

ARINC 600 Connectors are a recognized standard rack and panel connector for aircraft applications. The ARINC 600 is the successor to the ARINC 404 for many of the new avionics designs. Compared to the ARINC 404, the ARINC 600 features lower mating force contacts, increased contact count and a front release, floating keying system.

Amphenol's extensive product offering will meet the most demanding needs of our customers. At the design-in stage, Amphenol's sales engineers will work with you to select a connector from our standard product line or coordinate the design of an application specific connector. Amphenol's ARINC 600 rack and panel connectors are designed to meet all relevant ARINC 600 connector specifications.

#### FEATURES:

- Low insertion force contacts
- Both environmental and non-environmental versions
- Front removable keying posts
- Field replaceable inserts for size 22 and power contacts
- Up to 800 size 22 contact positions in one connector
- Crimp, coaxial, power, printed circuit, and wire wrap contacts
- Waveguide connections

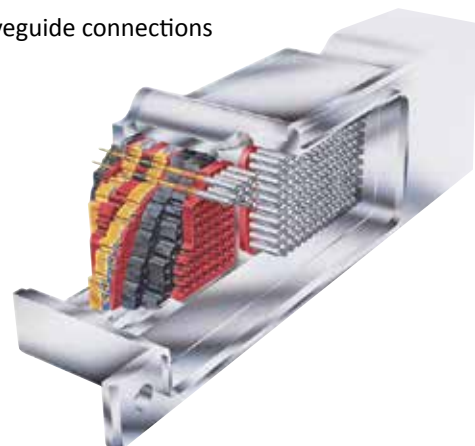



**R39 - RECTANGULAR 38999**

Amphenol's rectangular connector soars to meet higher expectations. The R39 series provides high performance in the severe environment demands of military specifications. Its lower profile translates into a smaller space-saving footprint. It delivers the same reliable, familiar benefits found in Amphenol's 38999 circular connectors: effortless installation, blind push-pull mating, extreme durability, quick mate.

**FEATURES:**

- Rectangular space savings
- Low profile
- High density 127 position inserts or mixed inserts with power, RF or fibre-optic available
- Blind mate
- Rugged
- Uses same contacts as standard 38999



**R58 - MIL-DTL-83733 and JN1122**

The R58 series are high performance environment resistant, rectangular connectors designed to exceed the requirements of MIL-DTL-83733 and to meet the EFA requirements of JN1122.

R58 Series Rectangular Connectors are well suited for hostile military aircraft applications where environment is an issue or shielding effectiveness and corrosion resistance is mandatory.

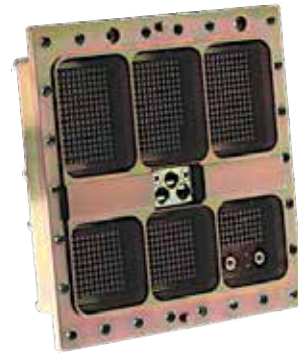

**R27 - MIL-DTL-83527**

The Amphenol R27 Series is a robust rectangular connector designed to meet or surpass all the requirements of the MIL-DTL-83527 specification and EN 3682 European Standard. This series is particularly well suited for military and commercial aircraft applications where harsh environmental issues are a concern. Connectors, shells, inserts, termination modules and contacts are sold separately or fully assembled.

These connectors are intermateable and interchangeable with filtered and non-filtered MIL-DTL-83527 connectors. A wide range of contact arrangements are available using contact types from Fibre Optic, Quadrax, Differential Twinax, Triax, Twinax and Coax to the standard size 12, 16, 20 and 22 contacts, in crimp and PCB.

These connectors are offered in both filtered and non-filtered designs. Filtered designs incorporate Amphenol's solderless construction which reduces stress on the ceramic elements resulting in superior thermal and physical shock performance and unparalleled long term reliability. Custom designs and features such as termination modules, backshells, unique insert patterns and integral shells are also available.

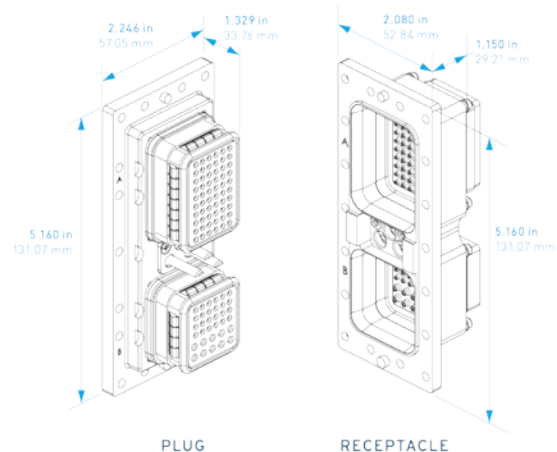



### Brush Rack & Panel Connectors

This connector series utilizes Amphenol's durable and reliable B3 contact system in a rugged, non-floating Rack and Panel connector. Included in this series are digital and power/digital "hybrid" insert arrangements. The hybrid series utilizes Amphenol's high performance RADSOK® power contacts along with Amphenol's proven B3 contact.

#### FEATURES & BENEFITS:

- High performance B3 brush contacts
- 0.100 inch x 0.100 inch square grid footprint
- Environmentally sealed at connector interface when mated (optional feature)
- Environmentally sealed connector mounting interface
- EMI protection is available at mounting surfaces and connector interface
- ESD protection is available – allows use of Class 3 hardened chips (4KV max. voltage)
- Tapered mating surface provides near zero X & Y plane movement between mated connectors



### EN3545 / 1900 Connectors

The composite EN3545 / 1900 connectors are available in sealed or unsealed versions and exist for copper or aluminum cable contacts versions. Locking as well as keying and fixing on structure is allowed by the pin & socket polarizers, available in standard screw version, ¼ turn or Quick Lock versions. This product range offers many contact configurations, from 50 contacts gage 20 to 5 contacts gage 8 (as per MIL-C-39029 and EN3155 spec.), as well as hybrid configurations and optical versions using Elio™ Termini (EN4531-101).



### RFM SERIES (Modular Floating Racks)

#### FEATURES:

- Plugs and receptacles with floating fixing
- Stackable modules
- Metallic modules guides
- Allows mis alignment between rack and panel : +/- 1.25 mm around the fixing screw

#### MAIN CHARACTERISTICS

- Blind mate, floating fixing
- High mating / unmating cycles (up to 5000)
- NF F 61-032 approved (Railways)
- Good behavior in vibrations
- Low insertion forces
- Power contacts (8,15, 25, 50, 60Amps)
- Modular : 5, 3 and 2 contacts modules with removable crimp and wire wrap contacts
- Metallic guiding pins

#### APPLICATIONS:

For applications demanding Density & Modularity RACK is the solution.

- Railway Racks
- Shelters
- Cabinets
- Power Racks
- Modular equipments
- Automatic assembly machines





### MIL-DTL-24308 D-SUB

#### FEATURES:

Amphenol M2000 Series D Sub Connectors are MIL Qualified & listed in QPL & meets the requirement of MIL-DTL-24308.

M2000 Series D Sub Connectors are subminiature rack & panel type with polarized shell & having pin/socket machined contacts which provide high reliability & density for the connectors. They are used in variety of applications due to it's versatile design where weight & dimensions are constraint factor.

#### APPLICATION:

- Military Information System
- Aerospace Communication System
- Industrial



### M83513 - MICRO-D

#### FEATURES:

Amphenol micro connectors provide small inter-connect solutions, which will exceed the requirements of the US military standard M83513. What differentiates Amphenol from the competition is our overall connector design. Custom solutions can easily be engineered to ensure exact performance in any application.

Amphenol is not limited to the traditional M83513 rectangular connectors but has also developed and produced circular connectors, strip line connectors, PC board connectors, and hybrid connectors utilizing power, signal, coaxial and fiber optics contacts.



### MMA - BLIND MATE

The MMA series is the ultimate solution to fit your needs:

- **Mini** - Compact blind mate
- **Modular** - Infinite possibilities
- **Arinc Contacts** - Proven Design

MMA combines many of the best features from popular product lines including Arinc 600's power, RF, Fiber Optic and Quadrx contacts, low mating forces and shrouded size 22 pins. Sealing capabilities are comparable to M83527 with a shell seal, face seal and grommet. Modular, removable inserts are effective for separating signal and power contacts, while providing ease of installation and customization in the field. Choose our 360° EMI spring option if shielding effectiveness is a concern. Customer specific designs lead to endless possibilities!



## Microminature Products

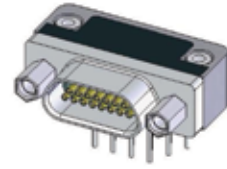
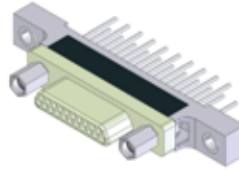

Metal / Plastic "100, 101, 102, 104"  
*Solder Cup, Pre-Wired, PCB Tails*

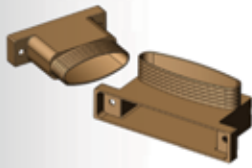

Backshells "MBS" and  
Accessories "HM05, MDCE"

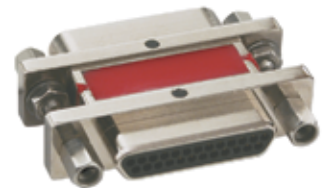
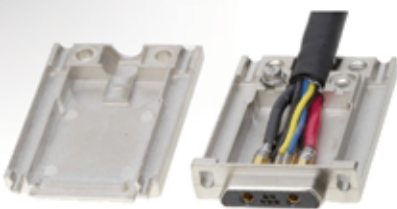

Integrated EMI Backshell

Strip Line "105"

Connector Saver

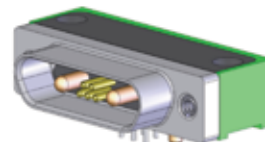

Hi-Density  
Card "106"

Filter Micro  
"M13"

Custom Design

**Possible Configurations:**

- ✓ Ruggedized
- ✓ Hi-Speed
- ✓ Fiber Optic & Power

**Termination Options:**

- ✓ PCB Tail Crimp
- ✓ Compliant Pin
- ✓ Flex Termination
- ✓ Surface Mount

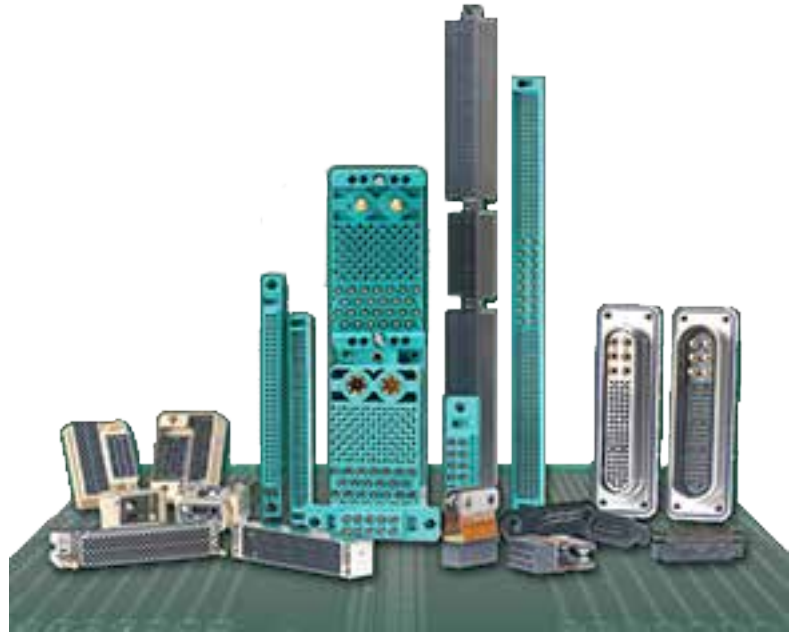

## Board Level Connectors

- SIHD
- HILINX
- HDAS
- SMASH
- SIAL
- MODULE-R
- HE8/127
- HE7-HE9/254
- THERMAL CLAMPS
- LMF-Low Mating Force  
Rectangular M55302
- Ruggedized VME64x, VITA 60,  
VITA 66 Interconnects
- R-SATA
- LRM (Line Replaceable Module)
- HDB3 High Density/ HSB3 High Speed
- Power to Board RADSOK
- UHD/NAFI Connectors with Fork & Blade  
Contacts

Amphenol is the leader in board level interconnection products through its long history of engineering expertise for product solution solving. New and innovative solutions are under development every day within the highly skilled engineering departments who are teamed with marketing product managers and production specialists.

**Brush Contact Technology:**

Meets the requirements of MIL-DTL-55302.

Provides high density in tight spacing, low mating/inmating forces, proven durability and long contact life.

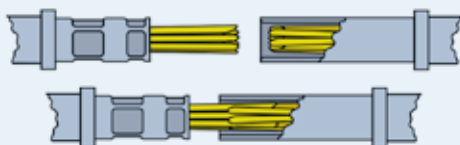

**Applications :**

- Medical equipment
- IC chip testers
- Telecommunications
- Military and Commercial Aviation
- Military Ground Vehicles
- GPS systems



**SIHD**

**FEATURES:**

Monolithic staggered grid connector, with floating capability feature.

**APPLICATIONS:**

- Radar
- On Board Computer
- Actuator



**HILINX**

**FEATURES:**

100% modular & hybrid connector. Unique M55302 modular interconnect. System of interlocking signal, power, fiber optics & HF modules.

**APPLICATIONS:**

- Engine
- Power Unit
- Landing Gear
- Braking System
- Ordnance



**HDAS**

**FEATURES:**

Monolithic high density PCB interconnect. Provides higher current rate capability, and extreme withstanding to harsh environments.

**APPLICATIONS:**

- On Board Computer
- Display Unit
- Actuator
- Engine
- Power Unit
- Landing Gear
- Braking System

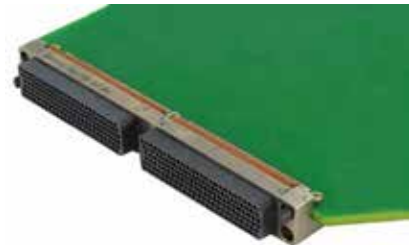

**SMASH**

**FEATURES:**

Highly robust advanced SEM E form factor connector. For the most demanding electronic packaging interconnects.

**APPLICATIONS:**

- Radar
- Engine
- Ordnance



**SIAL**

**FEATURES:**

Modular PCB interconnect, which provides various combinations of both signal and HF contacts inserts.

**APPLICATIONS:**

- Radar
- On Board Computer
- Actuator



**HE8/127**

**FEATURES:**

Proven legacy product, which meets various worldwide standard. Various features, including a wide range of hardware and locking devices.

**APPLICATIONS:**

- On Board Computer
- Display Unit
- Power Unit
- Landing Gear



**MODULE-R**

**FEATURES:**

Permits direct, blind-mate, and reliable interconnections within avionics racks.

**APPLICATION:**

- Modular avionics



**HE7-HE9/254**

**FEATURES:**

The standardized single or double-sided connector range

**APPLICATIONS:**

- Industrial
- Navy
- Security & Defense



**THERMAL CLAMPS**

**FEATURES:**

Chassis devices, which both help to dissipate components heating and block the daughter cards into the box slots grooves.

**APPLICATIONS:**

- Radar
- On Board Computer
- Actuator



### LMF-Low Mating Force Rectangular M55302

Amphenol's Low Mating Force Connectors are well known in the connector arena – with proven performance on the ground, in the air, and at sea. – In service for over 25 years, with over 50 million brush contacts fielded; and qualified for use on M1A2 Abrams, F-16 Falcon, F/A-22 Raptor, F-35 Lightning II, AIM-132 ASRAAM and many more applications.

#### FEATURES & BENEFITS:

- 0.100 inch center to center, square grid contact spacing
- Application flexibility (parallel boards, perpendicular boards, wire to board, end to end boards, card extenders)
- 2, 3 and 4 row contact arrangements with 10 to 100 contacts per row in one contact per row increments
- Military versions meet MIL-DTL-55302/166 through / 172
- Termination versatility; straight & 90° PCB stud, wire wrap & crimp
- Options on termination lengths and plating
- Front release/front removable contacts in Mother Board, Daughter Board and PC version; rear release/rear removable crimp contacts (size 22D) or printed circuit board pins provided with Input/Output connectors
- Accessories available for latching and polarization
- Up to 256 keyed, mating polarizations available
- Hybrids available – mix signal with power, RF or fiber optics
- Smaller sized connector designs with as few as 5 contacts per row
- RoHS compliant versions are available; consult an Amphenol Representative for more information.



### Ruggedized VME64x, VITA 60, VITA 66

#### Interconnects

Amphenol Aerospace developed the Ruggedized VME64x in response to the military trend towards VME64x and the utilization of COTS Boards and Chassis. The Amphenol Ruggedized VME64x interconnect has a more rugged interface than standard connectors for improved vibration durability. It meets the needs for a harsh environment connector requiring Level 2 maintenance. Military and commercial aviation, military vehicles and GPS systems are examples of markets that need the ruggedized VME64x connector solution from Amphenol. The Amphenol Ruggedized VME64x connector mounts to standard VME64x cards and backplanes, but it does not mate to other types of VME commercial connectors.



#### The new VITA based **VIPER** connector:

- VITA46 / 48/60 standards-compatible high-density PCB connector
- 10 + Gb / s high-speed signal response
- 1.8mm × 1.35mm grid that was optimized for differential signal
- High reliability due to four locations contact of beam-like terminal
- Extremely strong resistance to vibration, impact
- Robust frame made of aluminum alloy
- The ESD protection structure by ring with guide pin ■
- Fitting prevention structure and error due to key rotation



**R-SATA**

The new (Rugged) R-SATA style connector is perfectly suited as the primary internal storage interconnect for desktop and mobile PCs, connecting the system to peripherals such as hard drives, solid state drives, optical drives, and removable magnetic media drives. The R-SATA supports SATA 3.0 protocol, delivering 6.25 Gb/s data rates & beyond. Amphenol's R-SATA connector utilizes a Micro-Hyperboloid contact with proven performance. The Micro-Hyperboloid contact system offers low insertion and extraction forces, high durability counts and is resistant to shock, vibration and fretting corrosion.

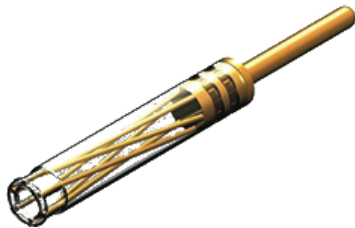

4 body styles for 7 pin & Combo 22 pin arrangements

- Right Angle Plug (Daughterboard)
- Straight Receptacle (Motherboard)
- Right Angle Receptacle (PC)
- Straight Plug - Parallel Boards

**FEATURES & BENEFITS:**

- Ruggedized SATA style
- Supports SATA 3.0 protocol (6.25 Gb/s) & beyond
- Rugged Micro-Hyperboloid contacts
- Low insertion/extraction force
- 20K mating cycles
- Resistant to shock, vibration & fretting corrosion
- 7 pin SATA & Combo 22 pin R-SATA contact arrangements (two differential pairs, 3 ground)
- Foot print compatible with 3M SATA Connectors



**LRM (Line Replaceable Module)**

Amphenol LRM Surface Mount Connectors meet the high density needs of today's integrated electronic modules. Amphenol goes beyond the usual board level product offering. That's what you expect from a worldwide interconnect product leader.



**MODULAR AVIONICS ARCHITECTURAL POSSIBILITIES:**

With its flexibility in design, Amphenol LRM interconnects are capable of meeting the wide variety of user requirements for a board mount connector.

- Thousands of combinations of inserts are possible - tailored to meet user needs
- LRM interconnects can be designed in 1, 2, 3 (and more) bay configurations with many shell designs available
- LRM digital (brush contact) inserts can be combined with inserts for power, fiber optics, RF, high speed and high amperage RADSOK® contacts





### HDB3 High Density/ HSB3 High Speed

This new connector series incorporates a higher density contact pattern and lower mated height than Amphenol's standard low mating force rectangular connectors. HDB3 connectors utilize the same durable and reliable B3 brush contact in a tighter .070" X .060" staggered grid pattern.

#### FEATURES:

- 100,000 mating cycles
- Operating Temperature of -65°C to 125°C
- 36 unique keying combinations
- HSB3 data rates up to 6.25 Gbps

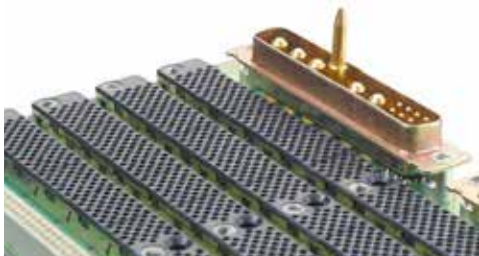

### UHD Connectors with Fork & Blade Contacts

- 0.100" x 0.050" staggered grid - High density optimizes trace routing through the backplane
- Compliant press-fit termination of backplane connectors - Provides a gas-tight interface with the printed circuit backplane without the need for soldering
- Tuning fork and blade contact system - A proven technology for high reliability
- Low insertion force (2.25oz/contact) - For easy mating
- Daughtercard connectors feature surface mount termination via rigid pins or flex circuit - Maximum design flexibility depending on the application requirements
- Rugged machined aluminum frames - Ensures excellent performance in harsh environments



### Power to Board

Amphenol **RADSOK**® solution offers options for high current single-point connections with a compact footprint design that can supply up to 120 Amps to the board. The hyperbolic grid contact provides more surface area with many points of contact for heat dissipation at the pin and socket interface. This lowers temperature rise and reduces potential failures. **RADSOK**® Power-to-Board products are designed to be applied manually by press-fit or by a re-flow solder process eliminating the need for additional wires and/or special crimp tools.

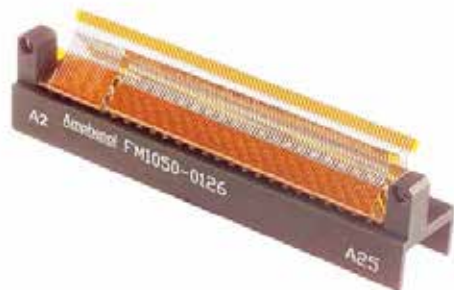

### NAFI Connectors with Fork & Blade Contacts

- Available in 2 through 4 rows - Offers maximum design flexibility
- Tested and qualified to MIL-C-28859 and MIL-C-28754 - Confirms the product meets specific performance requirements
- Tuning fork and blade contact system - A proven technology for high reliability
- Low insertion force (2.25oz/contact) - For easy mating
- Rugged machined aluminum frames - Ensures excellent performance in harsh environments
- Compliant pin press-fit, through-hole and flex circuit termination styles available - Support a variety of design application requirements

# Amphenol

Printed Circuit Board Technology

*The Leading Choice in Printed  
Circuit Board Technology*







## Printed Circuit Board Capabilities

Amphenol Printed Circuit Board Technology is a world leader in the printed circuit industry, building Board Level Connectors, PCB's, Backplanes, Flex and Rigid Flex products and Advanced Assemblies to meet our customers' demanding needs. Amphenol capabilities are among the world's broadest and most advanced, delivering consistent quality and reliability for demanding high-bandwidth systems and mission critical applications for more than 40 years. Proven engineering and manufacturing expertise eliminates design obstacles.



FLEX & RIGID FLEX

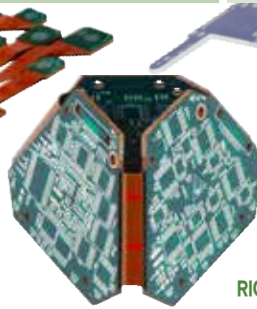

RIGID

<b>DESIGN FORMATS</b>	DXF PADS IGES	Mentor Graphics Cadence Allegro Design Services	Gerber Zuken
<b>MANUFACTURING FORMATS</b>	ODB++ (preferred) DXF	Gerber 274x / 274d Autoplot	DPF IPC-D-356 Excellon HPIGL
<b>INTERCONNECT FORMATION TYPES</b>	Via Fill Conductive Via Fill Non Conductive Blind (laser & mechanical)	Back Drilled Dual Diameter Electrically Isolated	Thru Hole Buried SMT
<b>FINISHED HOLE SIZE</b>	0.014" (0.373mm) 0.008" (0.203mm) 0.006" (0.152mm) 0.004" - 0.006" (0.101mm)	Compliant Pinned (rigid zone only) Via (A/R dependant) Buried Vias Microvias (up to 3 electrical layers)	
<b>FEATURES</b>	Lines / Spacing (Internal) 0.003" (0.0762mm) .5 oz. Copper	Lines / Spacing (External) 0.004" (0.1016mm) .5 oz.	Minimum Core Thickness 0.001" (0.0254mm)
<b>SURFACE FINISHES</b>	ENIG ENEPIG Immersion Silver Electrolytic Ni/Au (Hard & Soft)	OSP HASL Immersion Tin Reflowed Tin/Lead	

<b>PANEL SIZE</b>	18" x 24" 24" x 36" Other sizes available Current Largest is 38" x 54" (2 Layer)	24" x 54" (609.5mm x 1371.5mm) 30" x 44" (762.0mm x 1117.5mm) 36" x 42" (914.4mm x 1066.8mm)
<b>MAXIMUM PANEL THICKNESS</b>	.003" - .225" BookBinders Up to 0.500"	.500" (12.7mm)
<b>LAYER COUNT</b>	Up to 40 +	Up to 64 +
<b>ASPECT RATIOS</b>	Via Holes < 0.012                      7:1 Via Holes >= 0.012                    13:1 Blind Via Aspect Ratio                1.25:1	Compliant Holes >= 0.0225            17:1 Via Holes < 0.0225                    13:1 Blind Via Aspect Ratio                1.25:1
<b>MATERIALS</b> <small>Please contact Applications Engineering for the availability of additional materials - Hybrid Construction Available</small>	Polyimide - LF/ FR/AP/GI/TK LCP Silver Epoxy Shielding Copper Epoxy Shielding Soldermask FR-4/ -24, 26 and 28	FR4 Low & High TG Rogers 3000/4000/6000 Polyimide Megtron 6 & Megtron 7 Nelco 4000-13 SI & EP LCP
<b>IMPEDANCE SINGLE &amp; DIFFERENTIAL</b>	+/- 10%, +/- 7%	+/- 10% , +/- 7.5% , +/- 5.0%

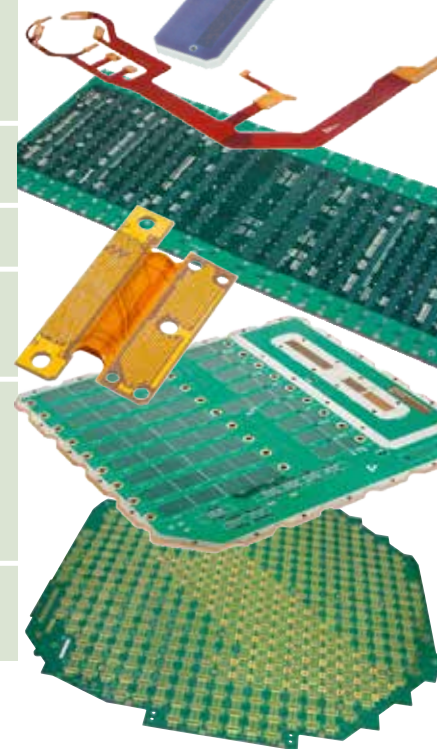



## Modular Connectors

- EN4165 SIM Modular Series 2
- MilAero SIM splice
- EN4165 / SIM Monomodule Connectors
- EN4165 / SIM connectors Series 3
- 3559 Push Pull connectors
- Specific SIM Modular Interconnection Unit
- 1900SIM modular connectors

Connectors  
to mate  
Mil / Aero

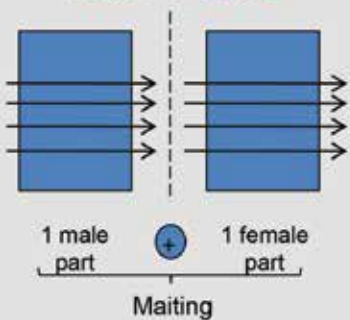

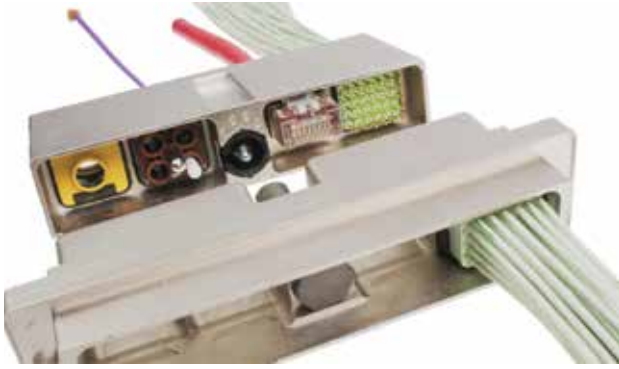

**EN4165 SIM Modular Series 2**

Amphenol's EN4165 / SIM connectors are rectangular, modular and fully sealed (IP66, 68 and 69K). They are suited for specific (optical termini, RJ45, QuadraX...) or standard electrical crimp and PCB contacts (as per MIL-C-39029 or EN3155 spec. from page 8 to 23). EN4165 spec. qualified, they come in metallic or composite versions, shielded or not (RoHS / REACH versions), and feature clicker nut or rack & panel plugs, and standard or flange-mount receptacles that can be assembled side by side on a panel providing unparalleled contact density. Available with Bright Nickel or Olive Drab Cadmium plating. 36 keying positions. Fire, Smoke and Toxicity conform to ABD0031 and FAR 25853.



**EN4165 / SIM Monomodule Connectors**

These modular EN4165 push-pull connectors are in light weight composite, shielded, sealed and available in 7 keyed versions. Fitted with the whole range of SIM / EN4165 modules, they present a compact design with a push-pull locking system for blind mating. Suited for in-flight entertainment and cabin systems applications



**MilAero SIM Splice**

This modular composite splice provides a reliable and simple connection between two EN4165 / SIM modules. Available with or without cable clamp, and/or flange, the SIM splice can be fixed on/under a structure or Feed-through. It can be fitted with the whole range of EN4165 / SIM modules.



**EN4165 / SIM connectors Series 3**

Amphenol's EN4165 / SIM connectors series 3 are scoop-proof rectangular, modular and fully sealed (IP66, 68 and 69K). They are suited for electrical crimp and PCB contacts (as per MIL-C-39029 or EN3155 spec. from page 8 to 22). EN4165 spec. qualified, they come in metallic versions, both standard or shielded, and feature clicker nut or rack & panel plugs, and standard or flange-mount receptacles that can be assembled side by side on a panel providing unparalleled contact density. Available with Olive Drab Cadmium plating. 36 keying positions. Fire, Smoke and Toxicity conform to ABD0031 and FAR 25853.



### 3559 Push Pull connectors

**FEATURES:**

- Mounted with SIM modules
- Multiple arrangements of contacts, size from 8 to 22 + ethernet
- Contacts gauge 8 to 26 AWG
- Contacts : MIL-C-39029, EN 3155, UTE C 93425 or ABS depending on contact types
- Connectors : AIRBUS ABS 1152, derived from EN 4165



### Specific SIM Modular Interconnection Unit

**FEATURES:**

- Fully customized units:
- Form according to space requirements
- Module type, number and arrangements, as required
- Contacts type (according to MIL-C-39029)
- Connectors: derived from EN 4165

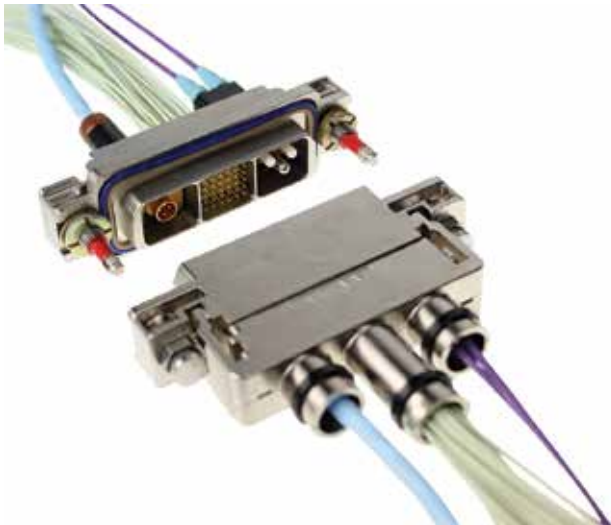

### 1900SIM Composite Connectors: NEW

The new 1900SIM connectors are modular (fitted with the whole range of EN4165 SIM modules), in light weight composite, shielded (including RoHS / REACH Bright Nickel and Black Zinc Nickel versions) or not, for sealed connections (IP66, 68 and 69K). They are designed to save time while installation: clip in backshells and various locking systems (standard, ¼ turn and Quick Lock Push Pull polarizers). They offer 36 keying positions and are conform to ABD0031 and FAR 25853 (Fire, Smoke and Toxicity).

# 1900SIM Connectors

Application: Aeronautic & Defence



screw



1/4 turn



Quick Lock



Except versions with Cadmium plating

# SIM Custom Connectors

Application : Defence

Connectors to mate  
Mil / Aero



Except versions with Cadmium plating

## FEATURES:

- Derived from EN4165
- Customized plates
- Metallic
- Shielding (Bright Nickel or Olive Drab Cadmium) for EMC
- Sealed - IP66 / IP68 / IP69K
- Possible coupling polarization
- Standard module range fitted with MIL-C-39029 / EN 3155 crimp contacts for electrical connection (size 23 / 22 / 20 / 16 / 12 / 8)
- Modules with PCB contacts (23 / 22 / 20 / 16 / 12)
- Also available: modules for RJ45, optical termini Lumiere®/Elio® or Amphelux®/Luxcis®, and special contacts (Quadrx, Twinax, Coax, Triax...)
- Operating Temperature : -55°C to +175°C (permanent)
- Conform to ABD 031 and FAR 25853

## BENEFITS:

- Custom design
- Robust (metallic versions)
- Compact and High contact density : Space saving
- Sealed
- Modularity
- "Compartmenting" is possible inside the connector shell (signal, power, optical, RJ45, Quadrx...)
- Time saving : Use plates or custom connectors instead of many stackable connectors --> easy implementation



# Distribution Solutions

- Bus Bar – Power Distribution
- Monoblock Assemblies
- Quick Junction Modules
- In-Line Junction 1119 Series
- Relay Sockets

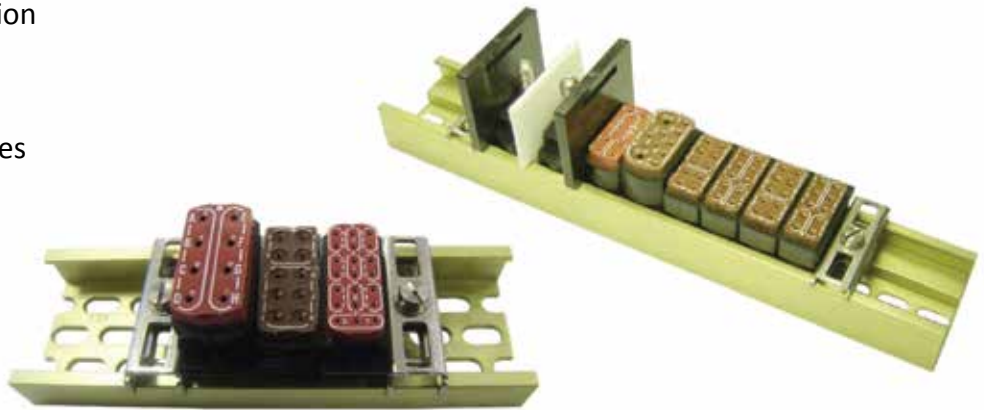

## Connectors for distribution Mil / Aero

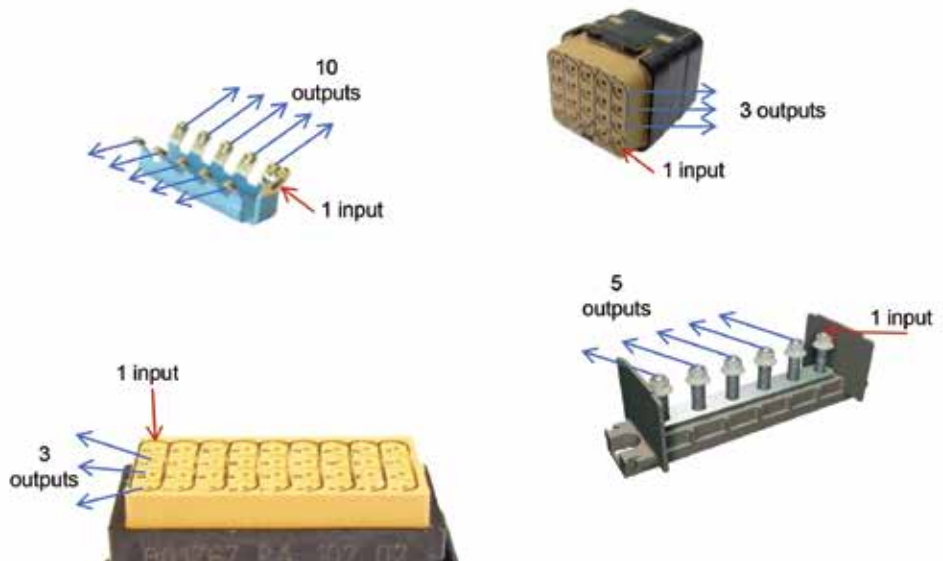
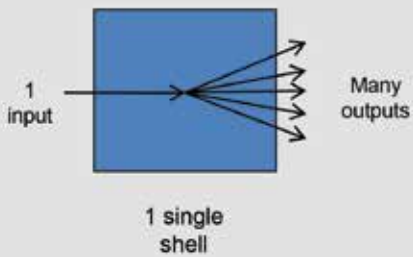



### Bus Bar – Power Distribution

Amphenol's bus bars provide a means of power distribution between power generator boxes, terminal blocks, and smaller terminal block interconnects. Bus bars are available in various standard sizes and shapes as well in custom designs. Bus bars present high mechanical resistance and are resistant to high temperatures.



### Monoblock Assemblies

Designed for power distribution purposes, the monoblock assemblies are made of terminal junction block, for copper or aluminum cable connections. Monoblock assemblies are available with individual or shunted terminals, from 1 to 12 terminals, in different diameters. The protective cover fixing, as well as the terminal assembly's fixing on structure are ensured by pillar bolts.



### Quick Junction Modules

Quick junction modules for signal and low current distribution, where sealing (IP66 / IP68 and IP69K), space and weight-saving are prime requirements. Specifically suited for wiring optimization, then offering weight and cost savings, these track-mounted modules (on metallic or composite track) are available from 8 contacts size 12 up to 36 contacts size 22 in different contact configurations. They also come in hybrid or ground versions, as well as PCB or component carrier versions. Fully REACH / RoHS compliant and conform to ABD0031 and FAR 25853 (Fire, Smoke and Toxicity).



### In-Line Junction 1119 Series

These in-line junctions are available in 1 to 4 contacts versions, for copper or aluminum cable contacts, and also exist in components carrier versions (diodes, resistors or fuses inserted). Fully sealed, compact, thin and easy to use, they are perfectly suited in a cable harness, to easily insert a component and change a signal, or simply to repair a damaged wire.



**Relay Sockets**

- NF C 93422 Relay Sockets
- MIL-S12883 Relay Sockets
- Solder Cup and PCB Relay Sockets
- Airbus-ATR Relay Sockets
- Railway Relay Sockets
- Quick connect Relay Sockets

**Features:**

- Adaptation device between a Relay and a Cable harness
- Lightweight composite
- For 4, 14 or 16 cts size 20 / 16 (crimp contacts)
- Operating temperature : -55°C to +150°C (permanent)
- Conform to ABD 031 and FAR 25853

**Benefits:**

- Lightweight (composite + silicone)
- Sealed connection

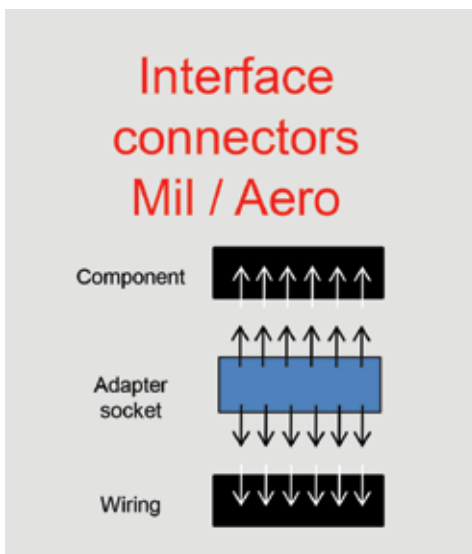

**Sockets for Lights**

**Features:**

- Adaptation device between a Lighting or a Push button and a Cable harness
- Lightweight composite
- For 18 cts size 22 (crimp contacts)
- Operating temperature : -55°C to +175°C (permanent)
- Conform to ABD 031 and FAR 25853

**Benefits:**

- Lightweight (composite)
- Sealed



**Sockets for Switch**

**Features:**

- Adaptation device between a Switch button and a Cable harness
- Lightweight composite
- For cts size 20 or 22 (crimp contacts or solder cup)
- Operating temperature : -55°C to +175°C (permanent)
- Conform to ABD 031 and FAR 25853

**Benefits:**

- Lightweight (composite)
- Sealed



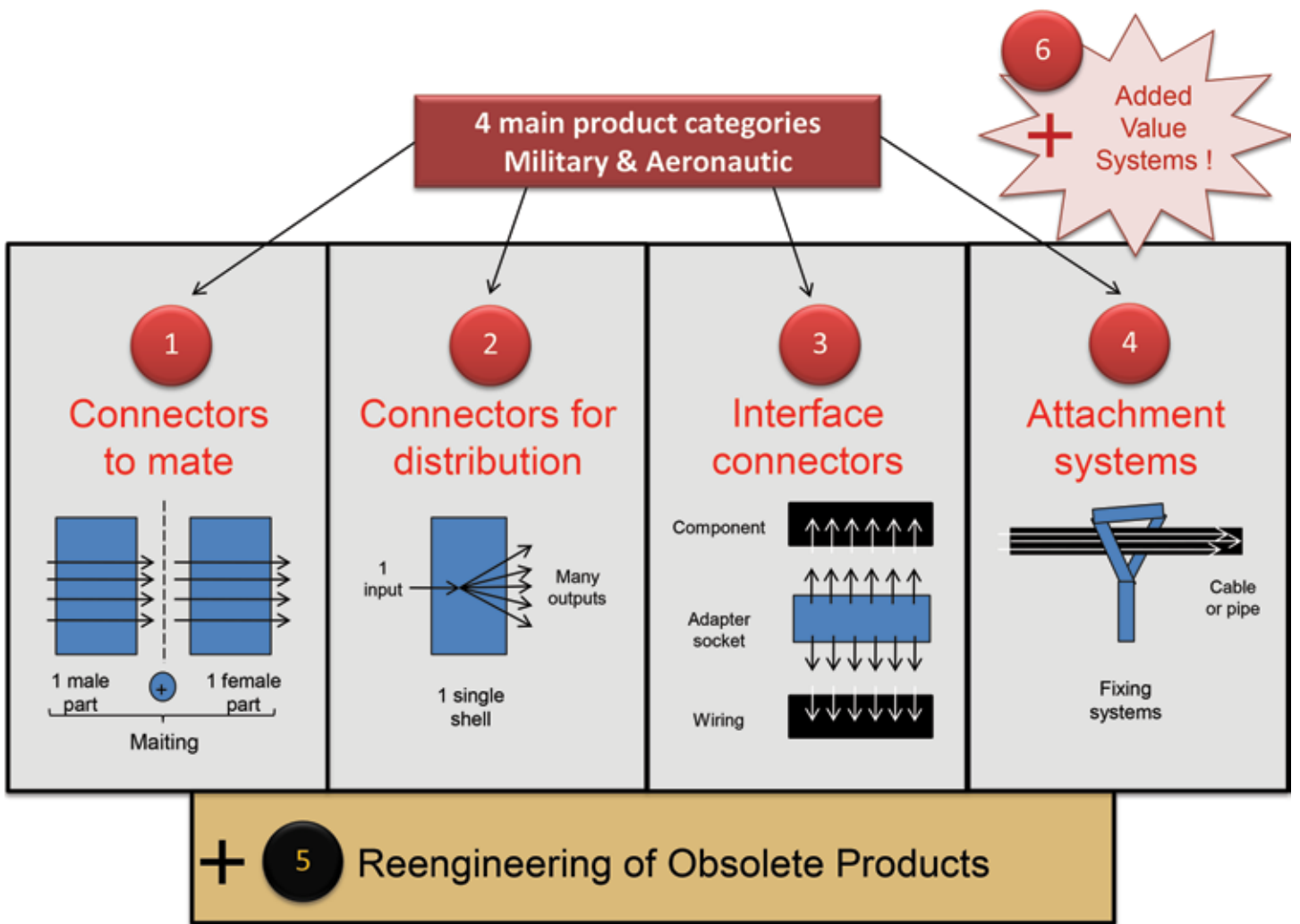

Added Value  
Systems  
Mil / Aero

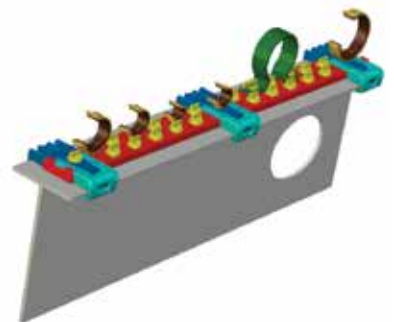

- ABS 1339 Monoblock Cable Clamps
- ABS 1339 Light Clamps
- CC516 Monoblock Cable Clamps
- Pipe Clamps
- Wiring Accessories



Attachment systems  
Mil / Aero

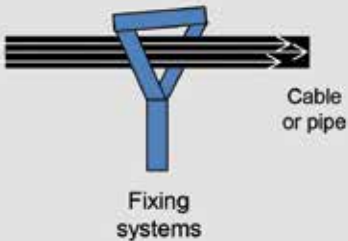

**ABS 1339 Monoblock Cable Clamps**



The monoblock ABS 1339 cable clamp allows the perfect fixing of electrical cable harnesses on structure. These cable clamps are fully designed in composite with silicon overmolding, providing a perfect bundle protection from shocks and vibrations. They are available in 8 sizes, for bundles from 3 to 48 mm, and are available for general (brown silicon) or fuel zone use (blue silicon). They are fixed on structure by a screw and are closed by a simple cable tie.



**ABS 1339 Light Clamps**

“The monoblock ABS 1339 Light cable clamp allows the perfect fixing of electrical cable harnesses on structure. Derived from the legacy ABS1339 standard, they offer up to 18% weight saving. These cable clamps are fully designed in composite with silicon overmolding, providing a perfect bundle protection from shocks and vibrations. They are available in 8 sizes, for bundles from 3 to 48 mm, and perfectly suited for general use. They are fixed on structure by a screw and are closed by a simple cable tie.



**CC516 Monoblock Cable Clamps**

The new monoblock CC5516 composite cable clamp are a lightweight version of standard metallic NSA5516 clamps, offering -60% weight saving. They are mounted on structure and locked in one step by screw. CC5516 clamps are available in 37 sizes, for bundles or pipes from 3 to 60 mm diameters. The overmoulded silicone provides a perfect protection of bundles and pipes from shocks and vibrations.



**Pipe Clamps**

Amphenol monoblock pipe clamps allows the perfect fixing of hydraulic pipes on structure. These pipe clamps are fully designed in composite with silicon overmolding, providing a perfect protection to the pipes from shocks and vibrations. Multiple versions are available, for general (brown silicon) or fuel zone use (blue silicon), with 1 to 5 holes from various and mixed diameters (from 6.3 to 19 mm). They are closed and fixed on structure by screws



**Wiring Accessories**

- Mil/Aero Wiring Accessories
- Railway/Industrial Wiring Accessories
- Mil/Aero Cable Clamps
- Railway/Industrial Cable Clamps
- P & Omega Clamps Mil / Aero accessories

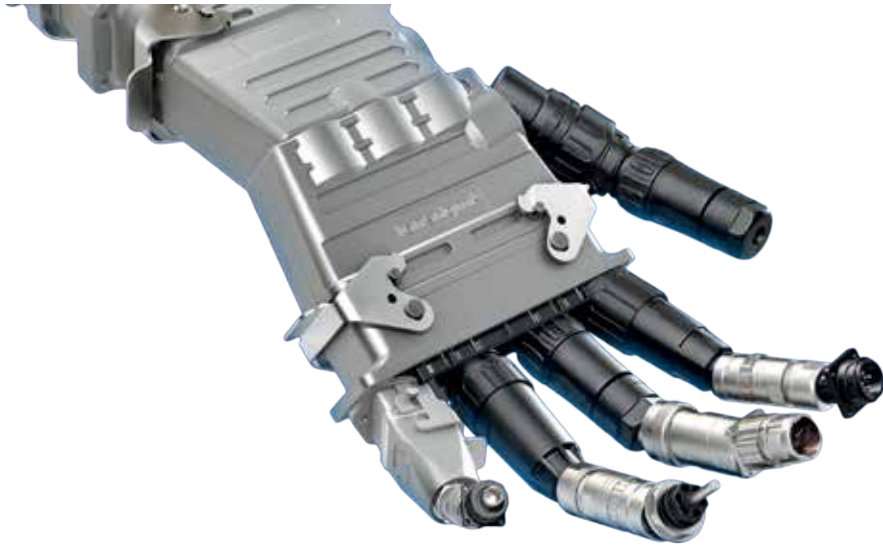

The Heavy Equipment market segment is one of the most demanding markets in the industry that is subject to environmental impacts. It includes agricultural vehicles, construction equipment, commercial vehicles, etc.

Amphenol has a wide range of connectors specially made for this market, starting with small sealed signal connectors, and going up to complex high-voltage and high-current solutions. Amphenol is a leading specialist for this market and understands the demands, therefore even customer-specific solutions are no problem for Amphenol to design.

## Heavy Duty Connectors



**RT360 Series**

Rugged metal circular connector with power and signal, multiple insert arrangements available.



**A Series**

Amphenol's A Series connectors encompass a wide range of products serving a variety of industries. With applications in Heavy Duty, Transportation, Marine, Diagnostic, Military, Alternative Energy and Agricultural industries, as well as spanning the gap between controlled to harsh environmental conditions, our A Series connectors keep you connected with confidence.



**M23 and M40**

DIN-style IP67-rated connector system with control & power for automation environments.

**FEATURES:**

- Sealed
- Submersible
- Vibration-resistant
- Cost Effective



### HEAVY|MATE C146

HEAVY|MATE C146 is a Modular Metal Connector Line consisting of:

- Hoods & Housings
- Inserts
- Contacts

#### FEATURES:

- Hybrid interconnections
- Good costs
- Voltage up to 1000V
- VDE, UL, CSA approvals
- Vibration proof
- High current
- Signal transmission
- High pole sizes
- IP65 to IP68
- Corrosion resistance
- Robust

#### BENEFITS:

- Indoor & outdoor applications
- A wide range of inserts for signal and power transmission
- A large variety in pole sizes from 3 up to 280 poles per connector
- Current ratings up to 250A per contacts and voltages up to 1000V
- A modular connector system to configure customized solutions

#### APPLICATION:

- Connections in harsh environment
- High number of poles or different kinds of signals transmitted
- Power and signal transmission outdoor
- Very safe & quick locking required
- Good EMC protection required



### HEAVY|MATE C146 MODULAR

In addition to HEAVY|MATE standard single insert system, Amphenol offers a new modular system that consists of:

- Hoods & Housings
- Frames
- Individually specialized modules
- Contacts

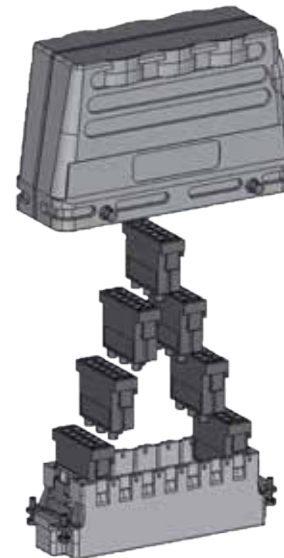

#### ADDITIONAL FEATURES:

- Fully intermateable with market standards
- Stamped contacts and the Radsok contact technology
- Wide range of Power- and Signal modules
- Large selection of contact-safe male contacts
- Easy Handling
- Robust metal or plastic frame options
- Modules are easy to assemble and disassemble

#### ADDITIONAL BENEFITS:

- Great cost savings potential
- Pin modules separately protected against mechanical influences
- High flexibility for future developments



Amphenol is the innovator and solution provider for all products that are to be used in the harsh and rugged environments (indoor or outdoor). Amphenol has a big spectrum of rugged and harsh environment interconnects ranging from IP65 to IP69K.



## Plastic Connectors



### LUMINUS

The Luminus Series are small, cost-effective connectors that are highly reliable and simple to use. With multiple product options to choose from, they meet MIL-T-81714, accept AS39029 & Stamped & Formed contacts, and are environmentally-sealed. Ideal for where space is limited, these innovative connectors feature a locking mechanism that ensures stability, and are suitable for blind-mating.

**FEATURES:**

- Quick Connect & Blind-Mate
- Multiple keying options
- Environmentally sealed
- Durable
- S&F contacts for non-military applications



### Pulse-Lok

Pulse-Lok® connectors have a unique locking coupling system with both tactile and audible confirmation for secure connections as well as quick-release action. These connectors are excellent for medical, factory automation, and instrumentation field applications. Many contact types are available, including signal, power, high-voltage, and Ethernet.

**FEATURES:**

- Quick release action
- Small package (.500 — 1.2" diameter)
- Tactile confirmation
- 1 to 78 contacts



### ECO|MATE

This connector meets the high requirements for applications in industrial technology. Easy operation, reduced dimensions and a more robust design are only a few of the features of the series.

The connector's main area of application is in the fields of plant construction and machine building. The connector is used for measuring and controlling applications as well as for power supply technology. The series is comprised of a large selection of housings and shapes and offers models with screw, solder and crimp termination.

#### FEATURES:

- Circular Connectors with 3+PE and 6+PE contacts
- Housing components from premium molding material
- Cable housing straight or angled
- IP 65/67 in mated condition (DIN EN 60526)
- Clamping ring or internal strain relief

#### ADVANTAGES:

- Quick and easy assembly
- Screwed cable gland with clamping ring
- Strain relief and mounted gasket all in one component
- Cable housing, straight or angled, for the cable diameter 6 - 12,5 mm
- Robust thread for the screwed cable gland
- Ergonomically designed product range for safe handling
- Pre-loaded ground contact
- Fastening for the protective caps on the housing of the receptacles



### Plastic Waterproof Connector Series

#### FEATURES:

- Mating Options: Screw Threaded Type, Lock Bayonet Type or Push Lock Type
- Contact options: Stamped, Screw-In, PCB and Solder (up to 30A per contact)
- Receptacle, Receptacle with cable, Over-molded With Cable & Field Installable available
- Insert Arrangement: Variety of configurations are available including:
  - Circular
  - Power
  - Hybrid
  - DVI
  - RJ
  - USB
  - D-Sub
  - HDMI
  - e-SATA
  - Fiber Optic
  - M type Sensor
  - IEEE 1394
- M8/M12 Series meets industry standards (IEC, NMEA2000, DeviceNet, EtherNet, I/P, Profibus & ProfiNet)
- Various sizes, over 1000 items
- UV Resistant
- IP65/66/67/68/69K waterproof (mated or unmated)
- PVC, PUR Jackets available for cables (Sun, Oil Resistant & Flame rated)
- UL/CSA Approval

#### ADVANTAGES:

- Cost Effective Solution
- High level of customization possibility
- Easy mating

Consider Amphenol as an extension of your design team, providing expert design and applications engineering assistance every step of the way to ensure program success. This is a perspective that other individual connector, board, and backplane assembly suppliers cannot match.



## Custom Solutions

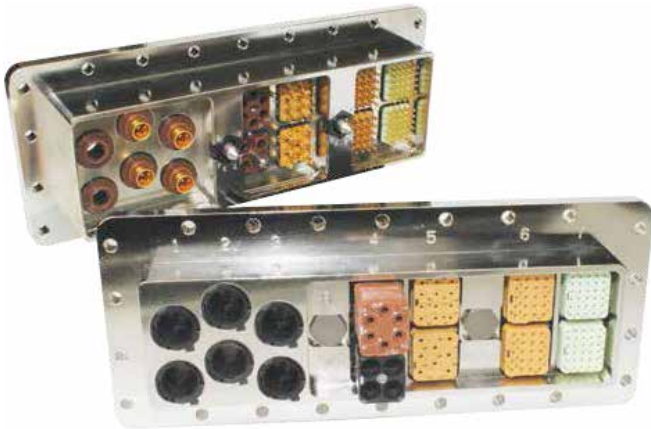

8 SIM modules  
6 quadrax contacts



Cable Harness Test Kit Box with  
MIL-Spec Circulars



Metallic custom  
design rackable  
modules



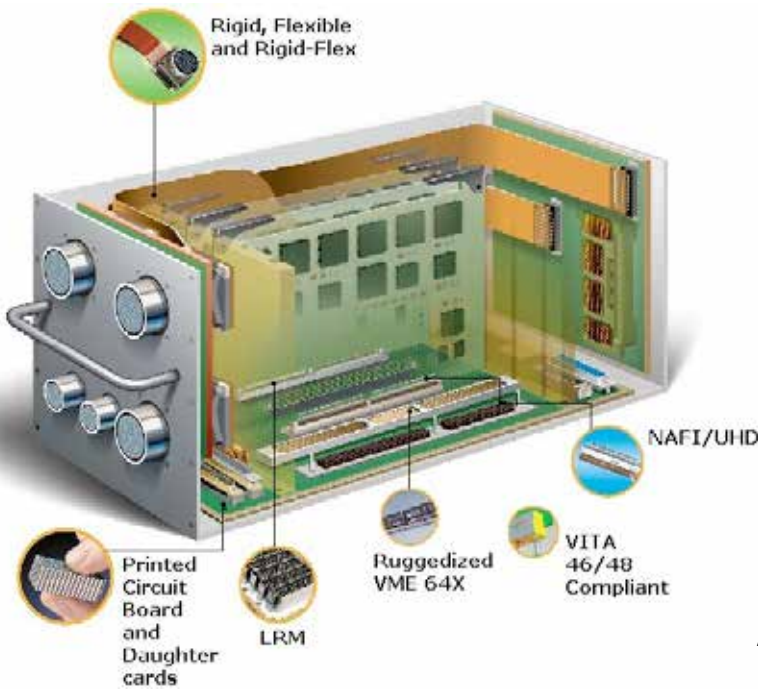

**Integrated Systems**

From Avionics to Ground and Naval Systems, Amphenol's Integrated Systems solutions are found aboard commercial airliners, helicopters, Navy and Air Force Fighters, C41 electronics, missiles, ground vehicles, Homeland Security Systems, and Navy warships around the world.

Amphenol Integrated Systems tackles problems such as PWB routing, signal integrity, mechanical robustness, and thermal reliability concurrently rather than independently by value-added applications engineering support. Solving complex packaging challenges depends on making sure that environmental, mechanical, and electrical factors are all addressed at the system-level. By taking this system-level perspective and focusing on these factors, Amphenol Integrated Systems is able to meet your program's most challenging packaging requirements.

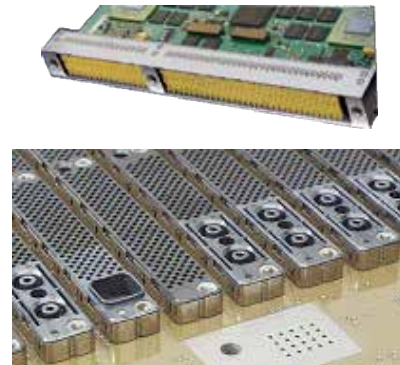

**Backplane Systems**

Amphenol is the leading manufacture of custom backplane assemblies using high - density, ruggedized, board to backplane interconnects. Our Backplane production capabilities include:

- Press-Fit
- Rigid and Rigid Flex PWB's
- Surface Mount Soldering
- Through-Hole Soldering
- Hybrid Optical Electric
- Conformal Coat
- Electrical test



Amphenol Backplanes are required to perform in the most demanding environments such as commercial airliners, Army helicopters, Navy and Air Force fighters, C41 electronics, missiles, ground vehicles, and Navy warships. Our Backplanes are used on programs such as the F-35 Joint Strike Fighter, F-22 Raptor, F-18 Super Hornet, Theater High Altitude Air Defense Radar, AH-64 Apache, RAH-66 Comanche, and AEGIS radars used on U.S. Navy warships.

Amphenol provides printed circuit processing capabilities that are among the world's most advanced, specializing in high technology multilayer backplane applications.



## Cable Assemblies

Amphenol is the world leader in the design, manufacture and supply of high-performance interconnect systems for military, commercial and industrial applications. Amphenol offers an extensive global portfolio of interconnect solutions for demanding and harsh environments which includes value added services.

Amphenol Ltd has an extensive design and manufacturing facility with the capability to offer customers added value services from cable systems to complete box build.

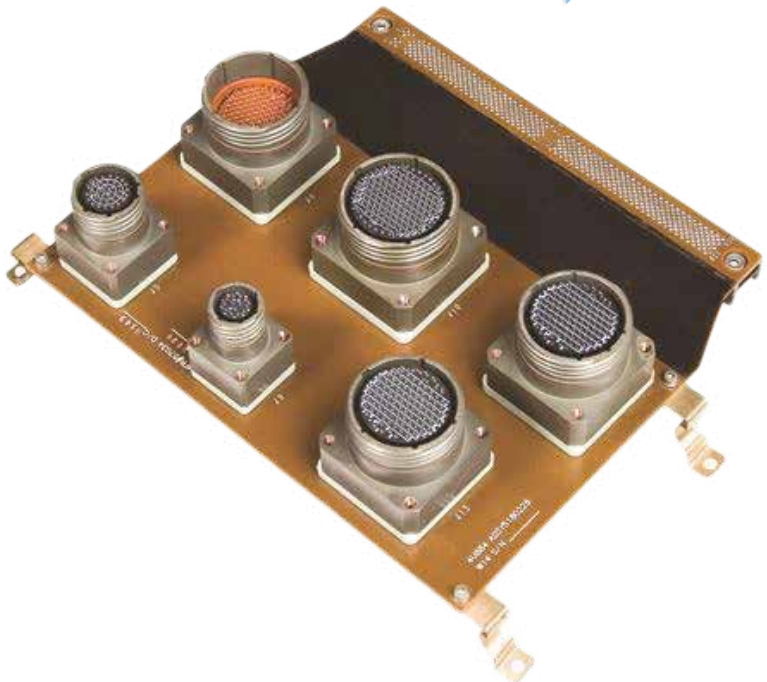
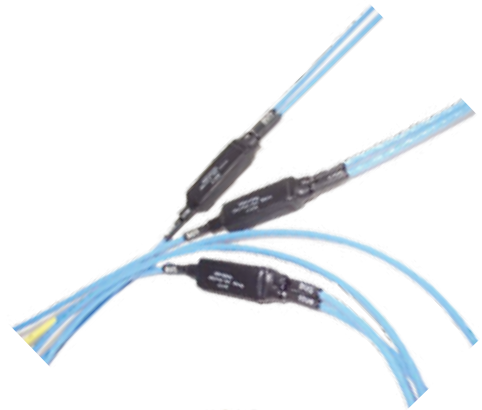



### Type 2 Double-Sided Flex

#### CHARACTERISTICS:

- Double-Sided, or Type 2 Flex, is a flex circuit based on two conductive layers of copper that are interconnected through Plated-Through-Holes (PTH's) or Via's creating electrically active circuitry on both conductive layers

#### FEATURES:

- World's most popular flex circuit design
- Ease of manufacturing or assembly
- Through holes are

#### OPTIONS:

- Silver shielding can be added for EMI protection
- Stiffeners can be added to "ruggedize" connection areas
- "Button Plating" or Pads only plating is a method when copper plating a circuit that must maximize its flexibility in its end application
- The ability to plate to a ground plane with one conductor layer is a good cost effective way for stripline impedance

#### BENEFITS:

- Cost effective and light weight
- Ease of assembly as circuit 1 and 1,000 are built with the same tooling guaranteeing reproducibility
- Military and IPC Specification qualified

#### OTHER Flex Options from Amphenol:

- Type 1 Single-Sided Flex
- Type 3 Multi-Layer Flex
- Type 4 Rigid Flex
- Type 4 Rigid Flex Book-Binder

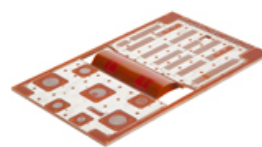
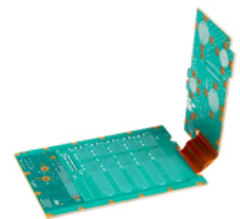

# Amphenol

*Connecting People & Technology*

MILITARY & AEROSPACE

**Amphenol**  
Türkiye&MiddleEast

[sales@amphenol.com.tr](mailto:sales@amphenol.com.tr)  
[www.amphenol.com.tr](http://www.amphenol.com.tr)

