



## Mini Encoder ED 26

Optical incremental encoder  
every resolution up to 2500 pulses per revolution  
Small and efficient

### Resolution

#### Every resolution from (Pulses/Revolution):

1 - 2500

### Type explanation

#### ED 26-3-2500-30-P-RC07

Encoder type	Incremental
Flange diameter	ø 26 mm
Case diameter	ø 26 mm
Number of channels	3 = A + B + M 6 = AA + BB + MM
Supply voltage	05 = 5 VDC ± 5% 30 = 10 ... 30 VDC
Output driver	D-RS422 P
Position of connection	R S
Connector	C07 = 7 pins Binder C12 = 12 pins M23
Shaft diameter	ø 4 mm

## Technical data

### Mechanical data

Rotational speed	? 10000 min <sup>-1</sup>
Torque	? 0,2 Ncm
Moment of inertia	2 g cm <sup>2</sup>
shaft loading	? 20 N radial ? 10 N axial
Angular acceleration	? 10 <sup>5</sup> rad/sec <sup>2</sup>
Weight	? 0,04 kg

### Environmental conditions

Vibration	100 ms <sup>-2</sup> (20 .. 2000 Hz)
Shock	1000 ms <sup>-2</sup> (11 ms)
Operating temperature	0 ... +80°C
Storage temperature	-30 ... +80°C
Atmospheric humidity	? 85% r.h.
Protection class	IP 54

### Electrical data

Scanning type	Optical, without contact
Transmitter, infrared	LED
Receiver	Photo-Array
Supply voltage	Vcc = 5 VDC ±5% Vcc = 10 ... 30 VDC
Power consumption	100 mA max.
Output frequency	? 300 kHz (Output D) ? 160 kHz (Output P)
Signal level	High > Vcc -2 V Low < 0,5 V
Load capacity of the outputs	20 mA

### Cable 3 channels

Wire colour	Signal
Brown	+Vcc
Grey	0 V GND
Green	Signal A
White	Signal B
Yellow	Signal M
Shield	N.C.

### Cable 6 channels

Wire colour	Signal
Brown/Green	+Vcc
White/Green	0 V GND
Brown	Signal A+
Green	Signal A-
Grey	Signal B+
Pink	Signal B-
Red	Signal M+
Black	Signal M-
Shield	N.C.

### Connector 7 pins Binder

Connection	Signal
Pin 1	0 V GND
Pin 2	N.C.
Pin 3	Signal A
Pin 4	Signal B
Pin 5	+Vcc
Pin 6	Signal M
Pin 7	Shield

### Connector 12 pins Binder

Connection	Signal
Pin A	+Vcc
Pin B	+Vcc Sense <sup>1)</sup>
Pin C	0 V GND
Pin D	0 V Sense
Pin E	N.C.
Pin F	Signal A-
Pin G	Signal A+
Pin H	N.C.
Pin J	Signal B+
Pin K	Signal B-
Pin L	Signal M+
Pin M	Signal M-

1) nur bei Vcc = 5 VDC TTL

### Output driver



## Outline drawing

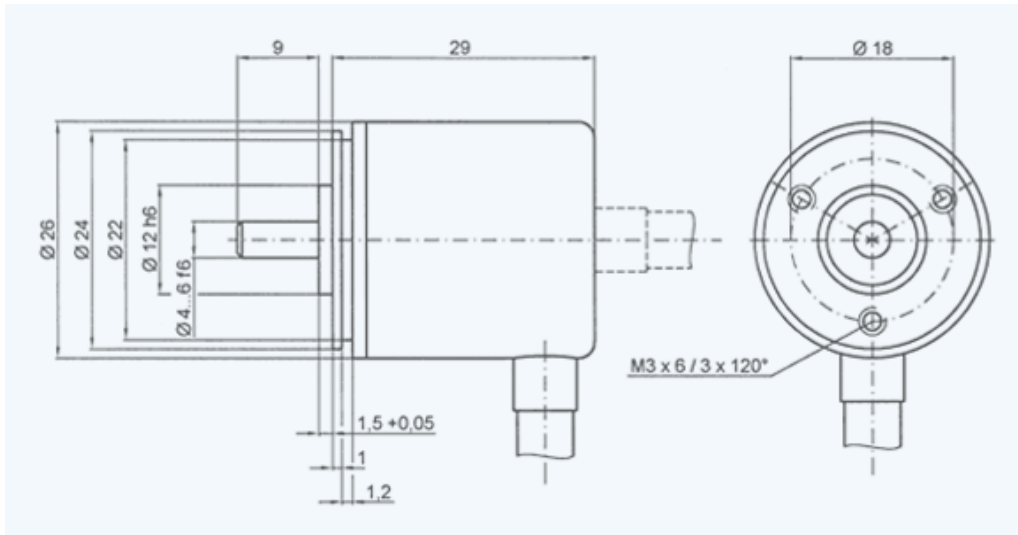

Version E 527-211 · Subject to change

INDUcoder® · INDUcoder Messtechnik GmbH, Kaiserstraße 316, 47178 Duisburg, Deutschland  
Tel: (0203) 57047-0, Fax: (0203) 57047-20, E-Mail: [info@inducoder.de](mailto:info@inducoder.de), Internet:  
[www.inducoder.de](http://www.inducoder.de)