

## Tecnoil Valve Model LN/L Ratings ANSI 150-2500

### Application

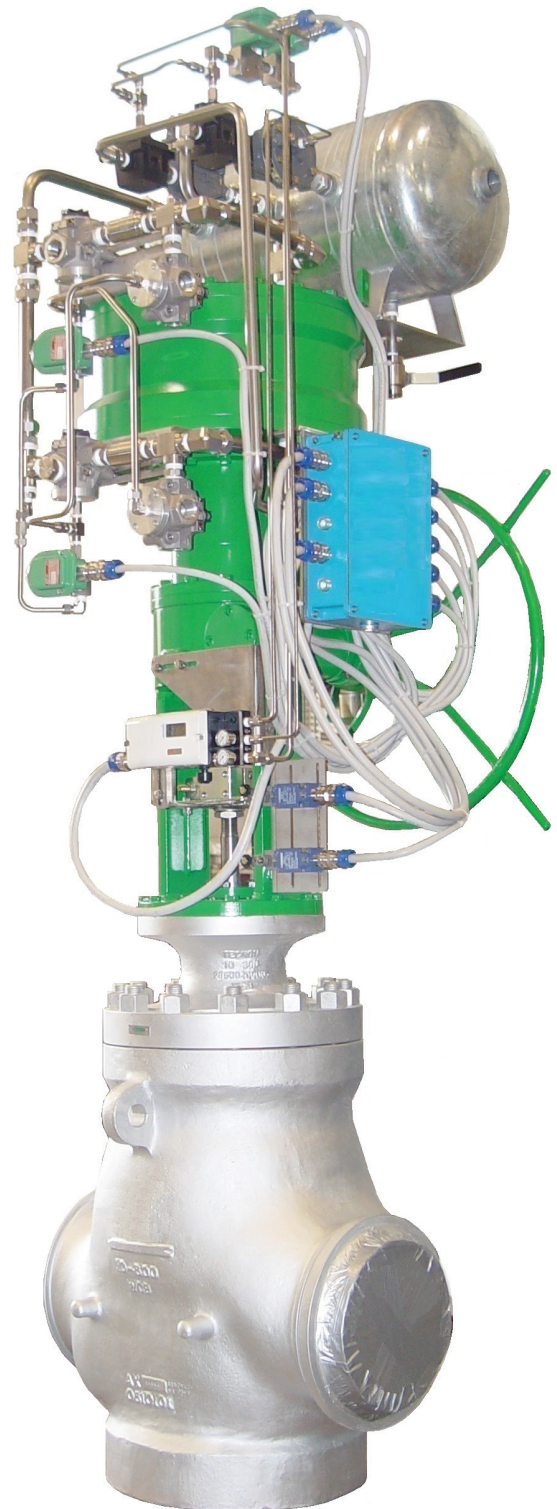
Tecnoil Valve Model LN/L has been designed to be used in the field of energy and oil/gas for temperatures up to 220°C. A wide range of materials offers a choice to suit the individual application. The smooth body flowpath reduces turbulence, minimising the effects of erosion and noise.

### Design Features

- Globe and angle body, cast or forged.
- Screwed-in seat trims or Quick-change.
- Trim type: Multi Cage.
- Inherently characterised trims available in Linear, Equal percentage, Quick opening.
- Both balanced and unbalanced trim designs available with soft seat insert option.

### Benefits

- Top-entry servicing with immediate access to plug and seat.
- Reduced inspection and maintenance costs.
- Trims compact and easy to install.
- Excellent flow capacity and control rangeability.
- Low actuating forces required with balanced trim styles.
- Reduces potential erosion and noise problems.



**Fig. 1 Tecnoil Valve Model LN/L Globe Valve  
10" ANSI 300 with pneumatic actuator**

## ENGINEERING DATA - TECNOIL VALVE Model LN/L Valves

### General

The Model LN/L range of valves has been developed to provide a cost effective, reliable and easily maintained control valve capable of working in rigorous environments.

The quick-change trim provides for easily accessible seat and trim components to minimise fitting and parts replacement times. Stem guided, in both balanced and unbalanced configuration, gives excellent rigidity and resistance to vibrations.

### End Connection Sizes/Types:

1 in. (25 mm) – 24 in. (600 mm).

Integral Flanges, Butt or Socket weld ends.

For further information, contact the factory.

### Design Standard:

ANSI B16.34.

### Valve Body Ratings:

ANSI 150 - ANSI 2500.

### Body Configurations:

Globe, Angle.

### Body Face to Face Dimensions:

See table page. 10.

### Bonnet Styles:

Standard.

### Standard Bonnet Packing:

Teflon/Chevrons.

### Trim type:

Multi Cage.

### Inherent Trim Characteristic:

Linear, Equal percentage, Quick opening.

### Plug Options:

Balanced, Unbalanced.

### Plug/Seat Leakage Class:

Class IV ANSI/FCI 70.2 as standard.

Options:

- Class V
- Class VI with soft seat insert.

### Paint:

A wide range of paint finishes are available.

### Inspection and Testing:

Inspection & Testing to Tecnoil Valve's standard as well as to almost all international standards / customer's requirements.

### Actuation

Various types of actuation are available, including: pneumatic piston and diaphragm spring, direct and reverse action. In addition electric and hydraulic actuators are available.

### Instruments:

A wide range of control instruments are available, including: Positioners, Air-filter Regulators, Volume Boosters, Lock-up valves, etc...

## Main Materials:

### Body / Bonnet:

Material Group or Common Name	Nominal Type	UNS	Forging Spec	Casting Spec. Equivalent	DIN W. No
Carbon steel	C-Mn-Fe	K03504	A105N	A216-WCB A216 WCC	1.0460
Low Temperature Carbon Steel	C-Mn-Fe	K03011	A350-LF2	A352-LCA A352-LCB A352-LCC	1.0566
Low Alloy Steel	1.1/4Cr-1/2Mo	K11572	A182-F11 cl2	A217-WC6	1.7335
	2.1/4Cr-1Mo	K21590	A182-F22 cl3	A217-WC9	1.7380
Stainless steel	304: 18Cr-8Ni	S30400	A182-F304	A351-CF8	1.4301
	304L: 18Cr-8Ni	S30403	A182-F304L	A351-CF3	1.4306
	316: 16Cr-12Ni-2Mo	S31600	A182-F316	A351-CF8M	1.4401
	316L: 16Cr-12Ni-2Mo	S31603	A182-F316L	A351-CF3M	1.4404
	316Ti	S31635	-	-	1.4571
	347: 18Cr-10Ni-Cb(Nb)	S34700	A182-F347	A351-CF8C	1.4550
	22Cr-5Ni-3Mo-N	S31803 S32205	A182-F51	A890-gr4A* A351-CD3MN	1.4462
	25Cr-7Ni-3.5Mo-N-Cu-W	S32760	A182-F55	A995-CD3MWCuN	-
Inconel 625	60Ni-22Cr-9Mo-3.5Cb	N06625	B564-N06625	A494-CW-6MC*	2.4856
-	-	C95800	-	B148-C95800	-

\* = no longer referenced in ANSI B16.34 2009

### Trim:

- 17-4 PH
- SS 316
- SS 316 + Stellite
- SS 410
- SS 410 + Stellite
- SS 420
- SS 304
- SS 304 + Stellite
- A182 F51
- A182 F53
- AISI 440C
- AL-Bronze
- INCONEL 625
- MONEL

For further information, contact the factory.

## VALVE BODY STYLE OPTIONS

The Tecnoil Valve Model CH/L provides two basic body styles: globe and angle. Many parts are interchangeable, with the exception of the valve bodies. The angle type has an optional venturi seat which may be specified in order to provide additional protection to the valve outlet.



Fig. 2 Globe Valve Body with Flanged Connections



Fig. 3 Angle Valve Body with Butt Welded Connections

## BONNET AND PACKING OPTIONS

Only forged, usually constructed in the same material as the valve body.

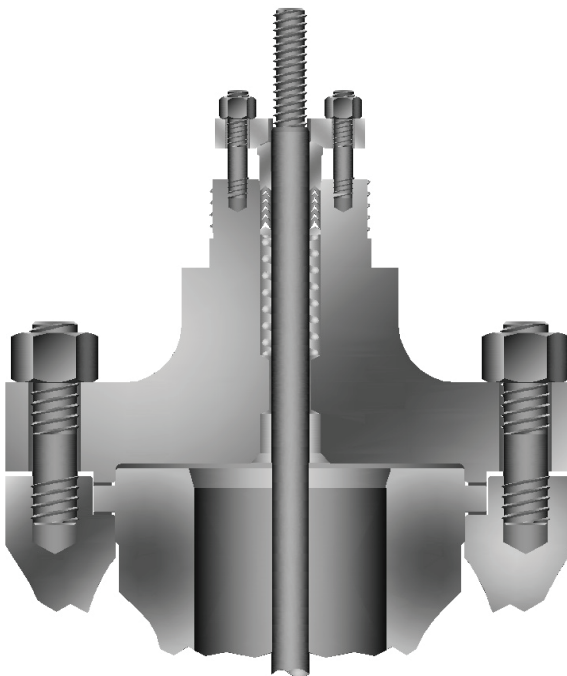


Fig. 4 Standard bonnet

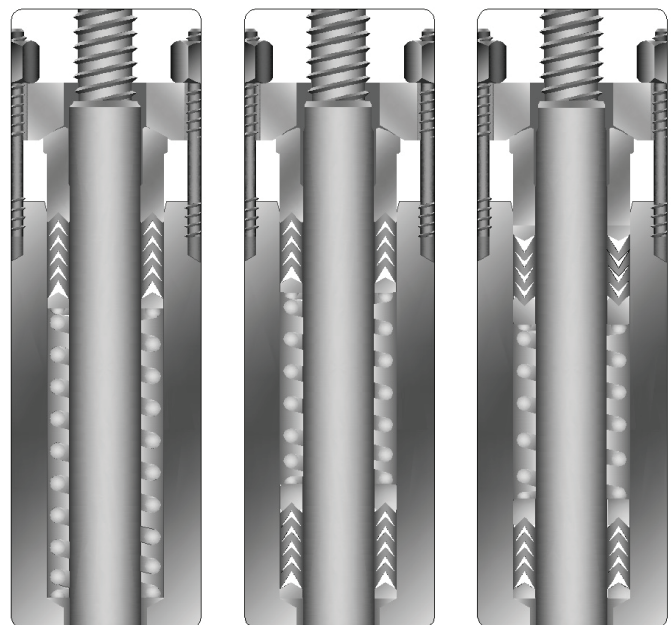


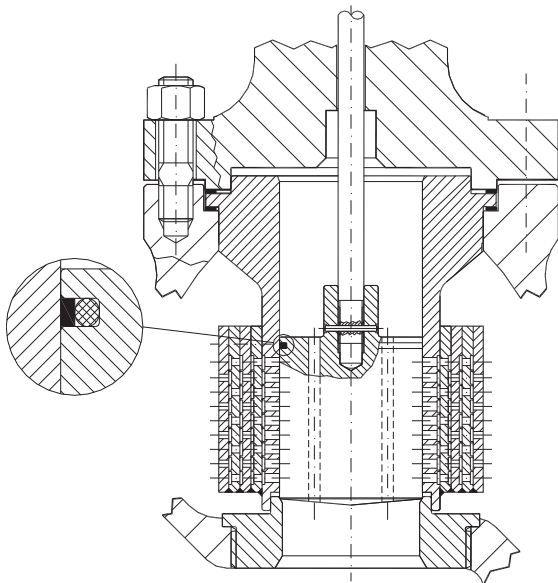
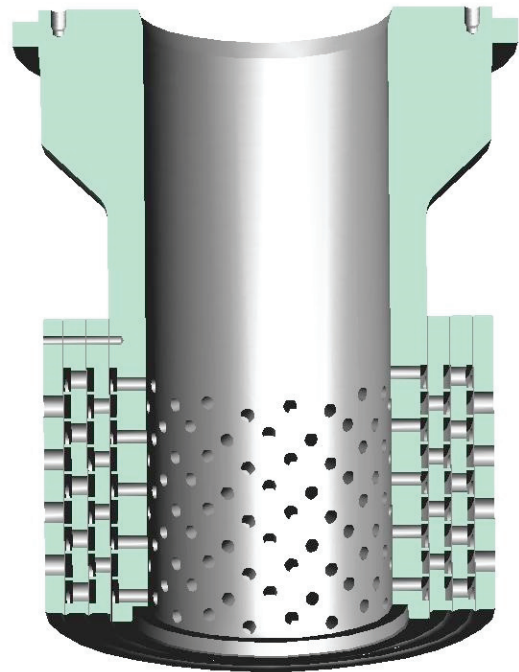
Fig. 5 PTFE Packing Options: Single, Double and Vacuum type

**STANDARD TRIM AVAILABLE**

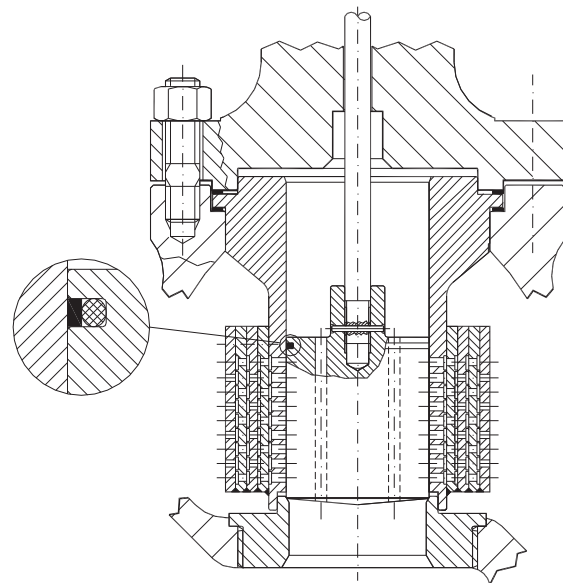
**Concentric Multi Cage Trim**

Multi cage trims are available for high pressure drop applications to prevent the onset of cavitation and to reduce noise levels.

- **Valve Size Options**  
Up to 24 in. ANSI 150-2500.  
For larger sizes consult factory.
- **Plug Options**  
Balanced, Unbalanced.
- **Characteristics Available**  
Equal percentage, Linear.
- **Direction of flow**  
Either direction, dependent upon application.
- **Hard Trim Options**
  - - Heat hardening.
  - - Stellite coating on seat and/or plug.
- **Soft seating**
  - Soft seat insert.

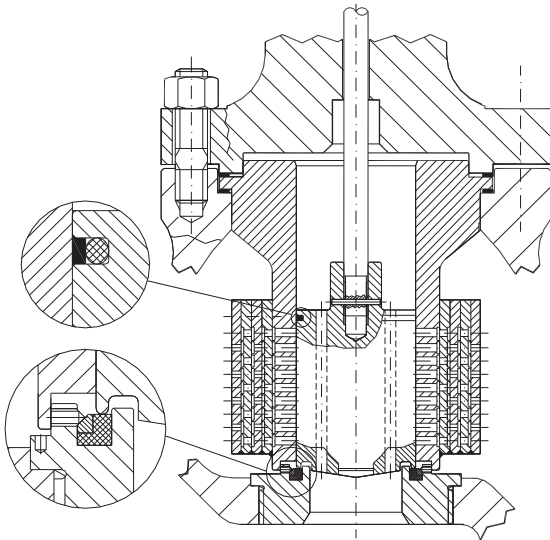


**Fig. 6 Threaded seat – Balanced trim**

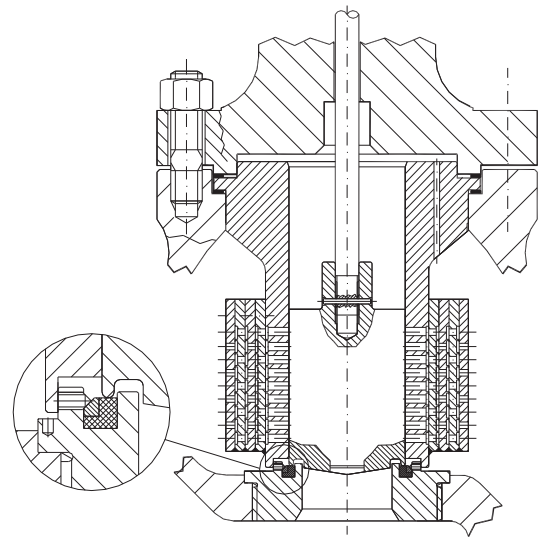


**Fig. 7 Threaded seat – Balanced trim**

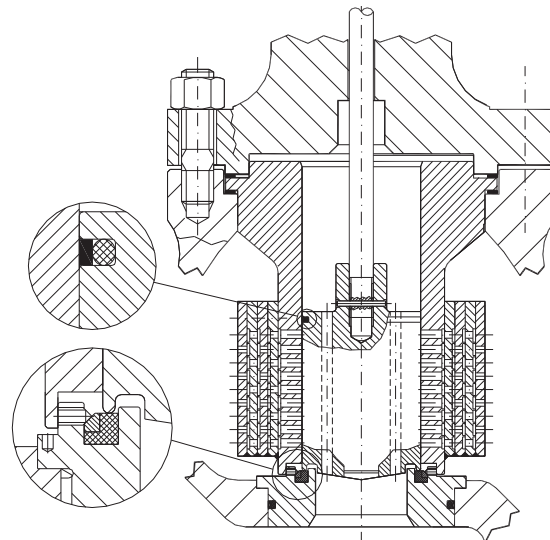




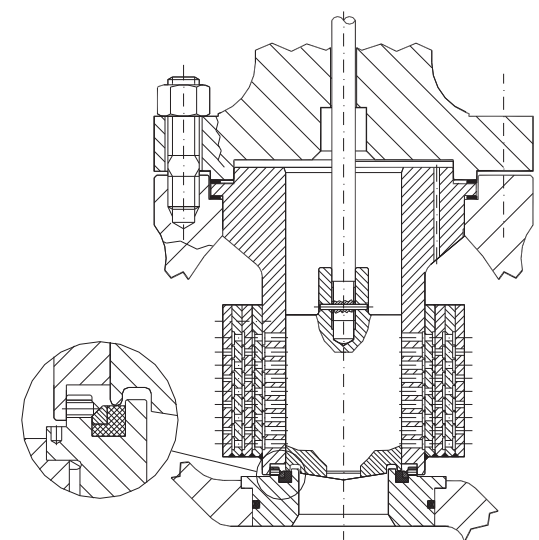
**Fig. 8 Threaded seat – Soft seat insert – Balanced trim**



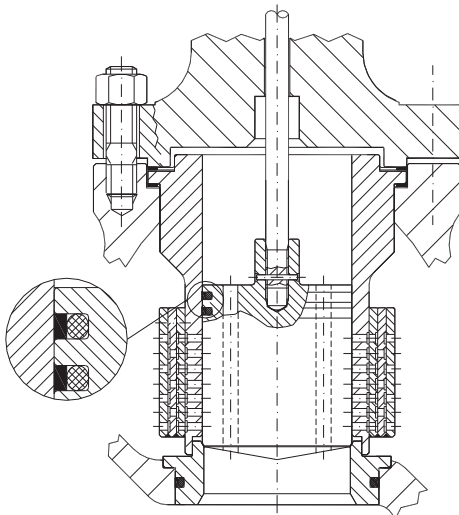
**Fig. 9 Threaded seat – Soft seat insert – Unbalanced trim**



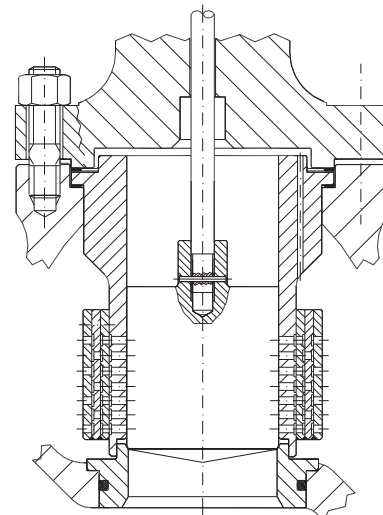
**Fig. 10 Quick-change seat– Soft seat insert – Balanced trim**



**Fig. 11 Quick-change seat – Soft seat insert – Unbalanced trim**



**Fig. 12 Quick-change seat – Balanced trim**



**Fig. 13 Threaded seat –Unbalanced trim**

## TECNOIL VALVE Model LN/L – DESIGN Cv Values

The Cv values detailed in the table are at the maximum rated valve travel.

Valve Size		Travel	2 CAGE – Cv *		
inches	mm	mm	ANSI 150 - 600	ANSI 900 - 1500	ANSI 2500
1"	25	25	6.2	6.2	6.2
1 1/2"	40	25	14.2	14.2	6.2
2"	50	25	21.8	19.2	19.2
3"	80	50	53	53	27
4"	100	60	131	109	53
6"	150	100	240	160	130
8"	200	130	444	282	282
10"	250	170	707	333	333
12"	300	170	943	785	380
14"	350	200	1260	1030	-
16"	400	230	1633	1159	-
18"	450	230	1946	1521	-
20"	500	230	2460	1700	-
24"	600	270	3132	2528	-

Valve Size		Travel	3 CAGE – Cv *		
inches	mm	mm	ANSI 150 - 600	ANSI 900 - 1500	ANSI 2500
1"	25	25	3.7	3.7	3.7
1 1/2"	40	25	8.3	8.3	3.7
2"	50	25	12.6	11.2	11.2
3"	80	50	31	31	15
4"	100	60	76	64	31
6"	150	100	140	94	76
8"	200	130	259	165	165
10"	250	170	413	194	195
12"	300	170	550	458	222
14"	350	200	738	600	-
16"	400	230	955	677	-
18"	450	230	1137	890	-
20"	500	230	1440	1000	-
24"	600	270	1830	1447	-

Valve Size		Travel	4 CAGE – Cv *		
inches	mm	mm	ANSI 150 - 600	ANSI 900 - 1500	ANSI 2500
1"	25	25	2.4	2.4	2.4
1 1/2"	40	25	5.5	5.5	2.4
2"	50	25	8.4	7.4	7.4
3"	80	50	21	21	10
4"	100	60	51	42	21
6"	150	100	93	62	50
8"	200	130	172	110	109
10"	250	170	274	129	129
12"	300	170	365	304	148
14"	350	200	490	399	-
16"	400	230	634	449	-
18"	450	230	755	590	-
20"	500	230	957	660	-
24"	600	270	1215	980	-

\* Values for specific customer applications can be designed into the valve - consult factory.

Valve Size		Travel	5 CAGE – Cv *		
inches	mm	mm	ANSI 150 - 600	ANSI 900 - 1500	ANSI 2500
1"	25	25	-	-	-
1 1/2"	40	25	3.7	-	-
2"	50	25	5.7	-	-
3"	80	50	14	14	7
4"	100	60	35	29	14
6"	150	100	64	43	34
8"	200	130	117	75	75
10"	250	170	187	88	88
12"	300	170	248	207	101
14"	350	200	333	271	-
16"	400	230	431	306	-
18"	450	230	514	402	-
20"	500	230	650	449	-
24"	600	270	827	667	-

Valve Size		Travel	6 CAGE – Cv *		
inches	mm	mm	ANSI 150 - 600	ANSI 900 - 1500	ANSI 2500
1"	25	25	-	-	-
1 1/2"	40	25	-	-	-
2"	50	25	-	-	-
3"	80	50	-	-	-
4"	100	60	24	-	-
6"	150	100	44	29	24
8"	200	130	80	51	51
10"	250	170	128	60	60
12"	300	170	170	142	69
14"	350	200	228	186	-
16"	400	230	296	193	-
18"	450	230	352	275	-
20"	500	230	446	308	-
24"	600	270	567	458	-

Valve Size		Travel	7 CAGE – Cv *		
inches	mm	mm	ANSI 150 - 600	ANSI 900 - 1500	ANSI 2500
1"	25	25	-	-	-
1 1/2"	40	25	-	-	-
2"	50	25	-	-	-
3"	80	50	-	-	-
4"	100	60	13	-	-
6"	150	100	29	11	-
8"	200	130	56	23	23
10"	250	170	89	29	13
12"	300	170	119	80	48
14"	350	200	160	115	-
16"	400	230	207	120	-
18"	450	230	246	193	-
20"	500	230	312	215	-
24"	600	270	397	320	-

\* Values for specific customer applications can be designed into the valve - consult factory.



Valve Size		Travel mm	8 CAGE - Cv *		
inches	mm		ANSI 150 - 600	ANSI 900 - 1500	ANSI 2500
1"	25	25	-	-	-
1 1/2"	40	25	-	-	-
2"	50	25	-	-	-
3"	80	50	-	-	-
4"	100	60	-	-	-
6"	150	100	15	-	-
8"	200	130	36	-	-
10"	250	170	50	-	-
12"	300	170	80	35	-
14"	350	200	90	50	-
16"	400	230	127	50	-
18"	450	230	172	114	-
20"	500	230	218	150	-
24"	600	270	277	223	-

\* Values for specific customer applications can be designed into the valve - consult factory.

## SEAT LEAKAGE

Seat leakage rates are normally measured in accordance with the ANSI/FCI 70-2 specification, using the leakage class designation. The following table defines the achievable leakage class with the plug/seat design available in the Model LN/L.

American National Standard Control valve seat leakage ANSI/FCI 70-2		
Leakage class	Valve type	Maximum seat leakage.
Class IV	Single seat control valve with metal to metal seats.	0,01% of rated valve capacity.
Class V	Single seat control valve with metal to metal seats having exceptional seat tightness or resilient seat dependant on application.	0,0005 ml/min per inch of orifice diameter per psi differential.
Class VI	Single seat control valve with resilient seating.	Bubble "tight".

## TECNOIL VALVE Model LN/L - DIMENSIONS

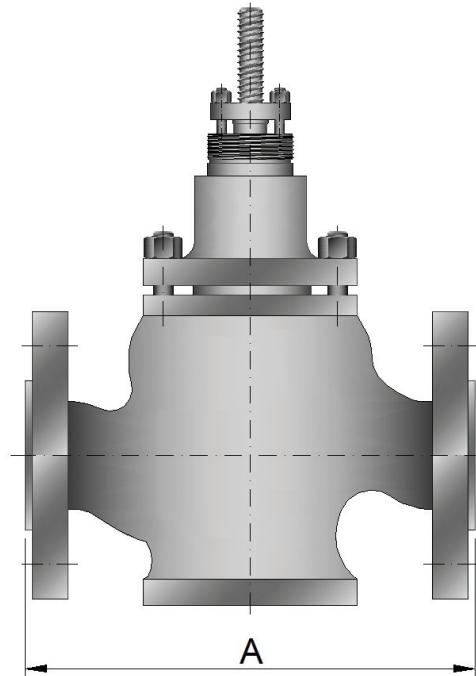


Fig. 14 Face to face dimensions

Valve size		A - Face to Face											
inches	mm	ANSI 150		ANSI 300		ANSI 600		ANSI 900		ANSI 1500		ANSI 2500	
		RF	RJ	RF	RJ	RF	RJ	RF	RJ	RF	RJ	RF	RJ
1"	25	184	197	197	210	210	210	-	-	254	254	308	308
1 1/2"	40	222	235	235	248	251	251	-	-	305	305	384	387
2"	50	254	267	267	283	286	289	-	-	368	371	451	454
3"	80	298	311	318	334	337	340	381	384	470	473	578	584
4"	100	352	365	368	384	394	397	457	460	546	549	673	683
6"	150	451	464	473	489	508	511	610	613	705	711	914	927
8"	200	543	556	568	584	610	613	737	740	832	842	1022	1038
10"	250	673	686	708	724	752	755	838	841	991	1001	1270	1292
12"	300	737	750	775	791	819	822	965	968	1130	1146	1422	1444
14"	350	889	902	927	943	972	975	1029	1039	1257	1276	-	-
16"	400	1016	1029	1057	1073	1108	1111	1130	1140	1384	1406	-	-
18"	450	1096	1109	1143	1159	1202	1205	1219	1232	1537	1559	-	-
20"	500	1202	1215	1254	1273	1318	1324	1321	1334	1664	1686	-	-
24"	600	1416	1429	1475	1497	1550	1560	1549	1568	1943	1971	-	-

