

Tecnoil Valve Model PC/L Ratings ANSI 150-2500

Application

Tecnoil Valve Model PC/L has been designed to be used in the field of energy and oil/gas for temperatures up to 220°C. A wide range of materials offers a choice to suit the individual application. The smooth body flowpath reduces turbulence, minimising the effects of erosion and noise.

Design Features

- Globe and angle body, cast or forged.
- Screwed-in seat trims or Quick-change.
- Trim type: Contoured.
- Inherently characterised trims available in Linear, Equal percentage, Quick opening.
- Both balanced and unbalanced trim designs available with soft seat insert option.

Benefits

- Top-entry servicing with immediate access to plug and seat.
- Reduced inspection and maintenance costs.
- Trims compact and easy to install.
- Excellent flow capacity and control rangeability.
- Low actuating forces required with balanced trim styles.
- Reduces potential erosion and noise problems.



**Fig. 1 Tecnoil Valve Model PC/L Globe Valve
8" ANSI 600 with pneumatic actuator**

ENGINEERING DATA - TECNOIL VALVE Model PC/L Valves

General

The Model PC/L range of valves has been developed to provide a cost effective, reliable and easily maintained control valve capable of working in rigorous environments.

Quick-change trim provides for easily accessible seat and trim components to minimize fitting and parts replacement times. Stem guided contoured trim, in both balanced and unbalanced configuration, gives excellent rigidity and resistance to vibrations.

End Connection Sizes/Types:

1 in. (25 mm) – 24 in. (600 mm).
Integral Flanges, Butt or Socket weld ends.
For further information, contact the factory.

Design Standard:

ANSI B16.34.

Valve Body Ratings:

ANSI 150 - ANSI 2500.

Body Configurations:

Globe, Angle.

Body Face to Face Dimensions:

See table page. 9.

Bonnet Styles:

Standard.
For further information, contact the factory.

Standard Bonnet Packing:

Teflon/Chevrons.

Trim type:

Contoured.

Inherent Trim Characteristic:

Linear, Equal percentage, Quick opening.

Plug Options:

Balanced, Unbalanced.

Plug/Seat Leakage Class:

Class IV ANSI/FCI 70.2 as standard.

Options:

- Class V
- Class VI with soft seat insert.

Paint:

A wide range of paint finishes are available.

Inspection and Testing:

Inspection & Testing to Tecnoil Valve's standard as well as to almost all international standards / customer's requirements.

Actuation:

Various types of actuation are available, including: pneumatic piston and diaphragm spring, direct and reverse action. In addition electric and hydraulic actuators are available.

Instruments:

A wide range of control instruments are available, including: Positioners, Air-filter Regulators, Volume Boosters, Lock-up valves, etc...

Main Materials:

Body / Bonnet:

Material Group or Common Name	Nominal Type	UNS	Forging Spec	Casting Spec. Equivalent	DIN W. No
Carbon steel	C-Mn-Fe	K03504	A105N	A216-WCB A216 WCC	1.0460
Low Temperature Carbon Steel	C-Mn-Fe	K03011	A350-LF2	A352-LCA A352-LCB A352-LCC	1.0566
Low Alloy Steel	1.1/4Cr-1/2Mo	K11572	A182-F11 cl2	A217-WC6	1.7335
	2.1/4Cr-1Mo	K21590	A182-F22 cl3	A217-WC9	1.7380
Stainless steel	304: 18Cr-8Ni	S30400	A182-F304	A351-CF8	1.4301
	304L: 18Cr-8Ni	S30403	A182-F304L	A351-CF3	1.4306
	316: 16Cr-12Ni-2Mo	S31600	A182-F316	A351-CF8M	1.4401
	316L: 16Cr-12Ni-2Mo	S31603	A182-F316L	A351-CF3M	1.4404
	316Ti	S31635	-	-	1.4571
	347: 18Cr-10Ni-Cb(Nb)	S34700	A182-F347	A351-CF8C	1.4550
	22Cr-5Ni-3Mo-N	S31803 S32205	A182-F51	A890-gr4A* A351-CD3MN	1.4462
	25Cr-7Ni-3.5Mo-N-Cu-W	S32760	A182-F55	A995-CD3MWCuN	-
Inconel 625	60Ni-22Cr-9Mo-3.5Cb	N06625	B564-N06625	A494-CW-6MC*	2.4856
-	-	C95800	-	B148-C95800	-

* = no longer referenced in ANSI B16.34 2009

Trim:

- 17-4 PH
- SS 316
- SS 316 + Stellite
- SS 410
- SS 410 + Stellite
- SS 420
- SS 304
- SS 304 + Stellite
- A182 F51
- A182 F53
- AISI 440C
- AL-Bronze
- INCONEL 625
- MONEL

For further information, contact the factory.

VALVE BODY STYLE OPTIONS

The Tecnoil Valve Model CH/L provides two basic body styles: globe and angle. Many parts are interchangeable, with the exception of the valve bodies. The angle type has an optional venturi seat which may be specified in order to provide additional protection to the valve outlet.



Fig. 2 Globe Valve Body with Flanged Connections



Fig. 3 Angle Valve Body with Butt Welded Connections

BONNET AND PACKING OPTIONS

Only forged, usually constructed in the same material as the valve body.

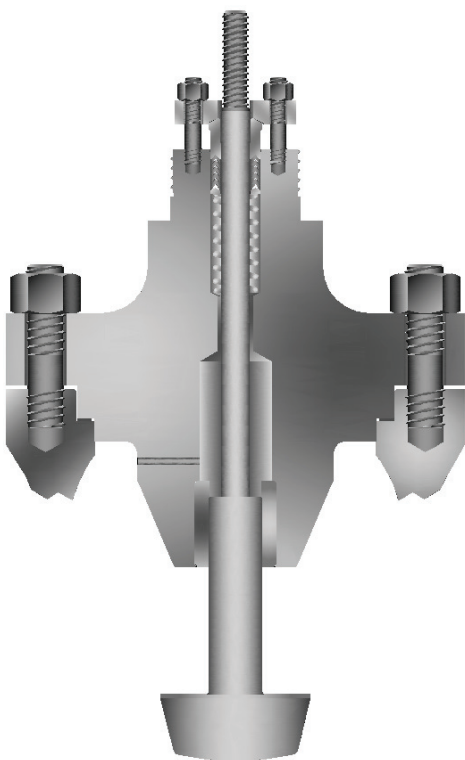

Fig. 4 Standard bonnet for unbalanced trim

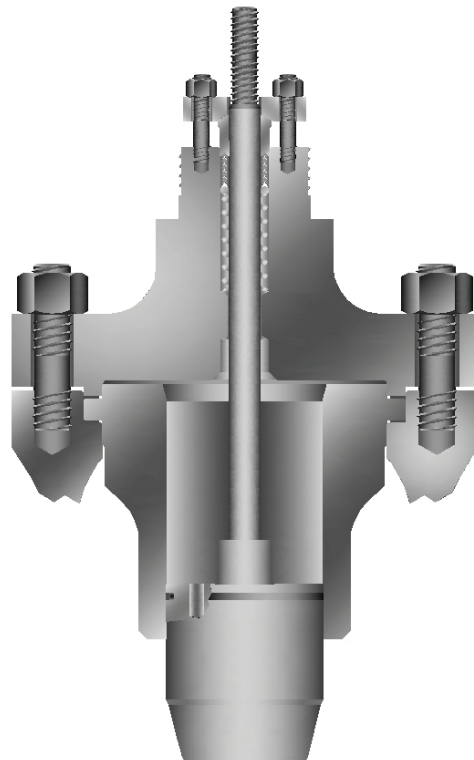

Fig. 5 Standard bonnet for balanced trim

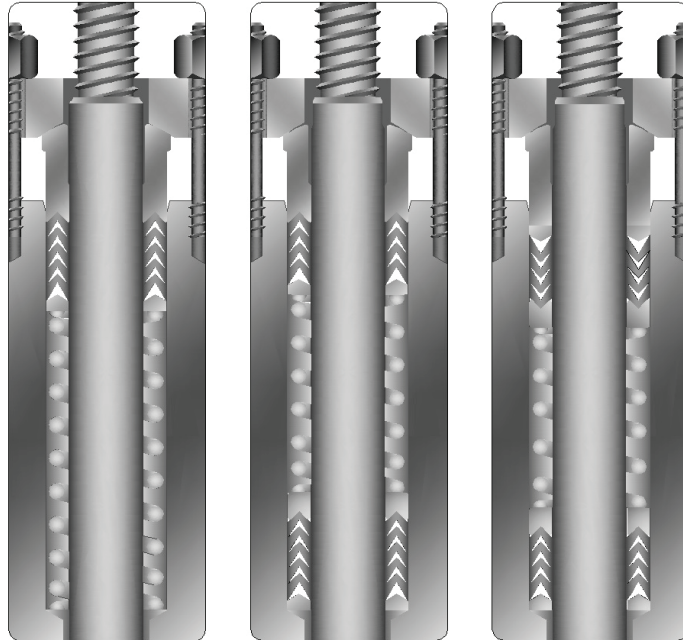

Fig. 6 PTFE Packing Options: Single, Double and Vacuum type

STANDARD TRIM AVAILABLE

Contoured Trim

Contoured trims are available in balanced and unbalanced configurations, used for modulating and ON/OFF service.

- **Valve Size Options**
Up to 24 in. ANSI 150-2500. For larger sizes consult factory.
- **Plug Options**
Balanced and unbalanced, with metal to metal seating faces or soft seat insert.
- **Characteristics Available**
Linear, Equal percentage, Quick opening.
- **Direction of flow**
Either direction, dependent upon application.
- **Hard Trim Options**
 - Heat hardening.
 - Stellite coating on seat and/or plug.
 - Solid stellite seat and plug.
- **Soft seating**
Soft seat insert.



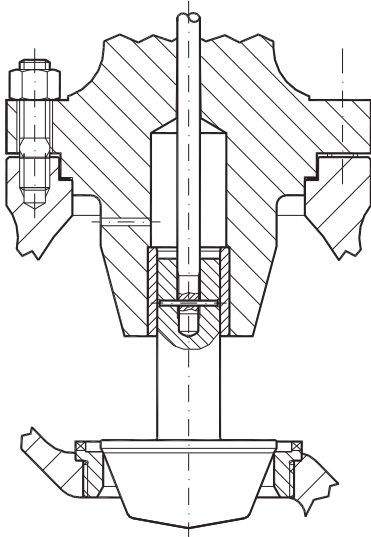

Fig. 7 Threaded seat, Unbalanced trim

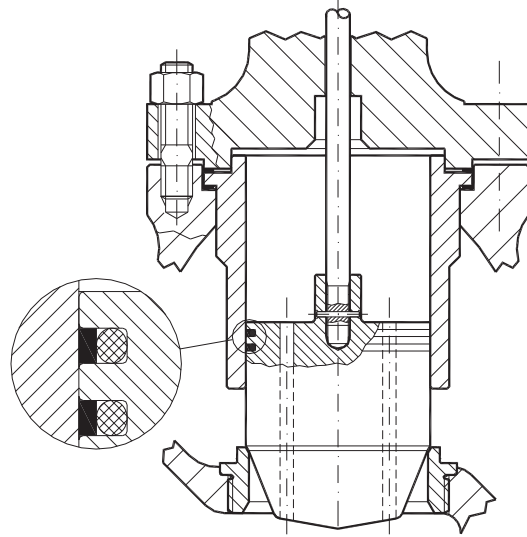

Fig. 8 Threaded seat, Balanced trim

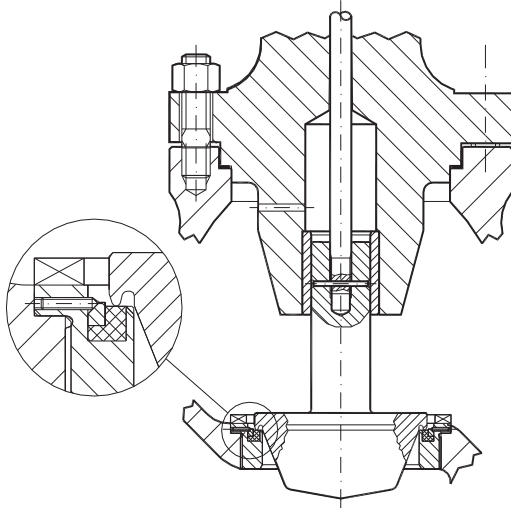

Fig. 9 Threaded seat, soft seat insert, Unbalanced trim

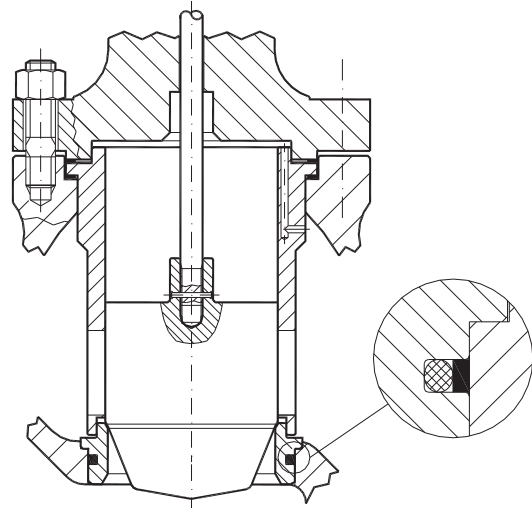

Fig. 10 Quick change seat, Unbalanced trim

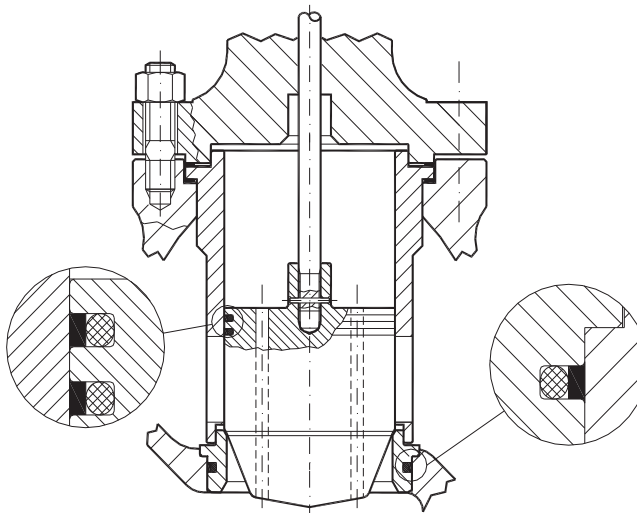

Fig. 11 Quick change seat, Balanced trim

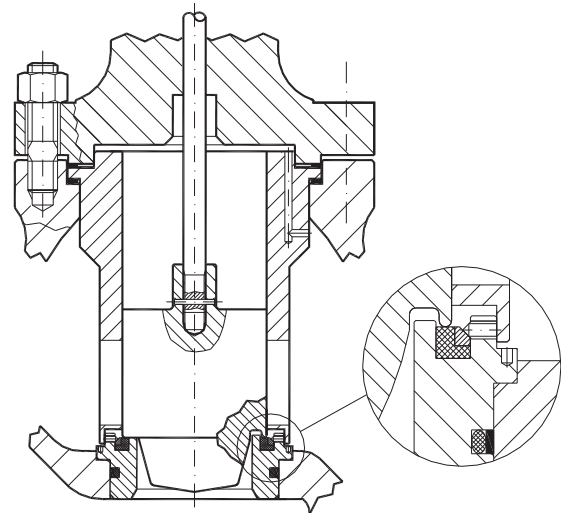

Fig. 12 Quick change seat, soft seat insert, Unbalanced trim

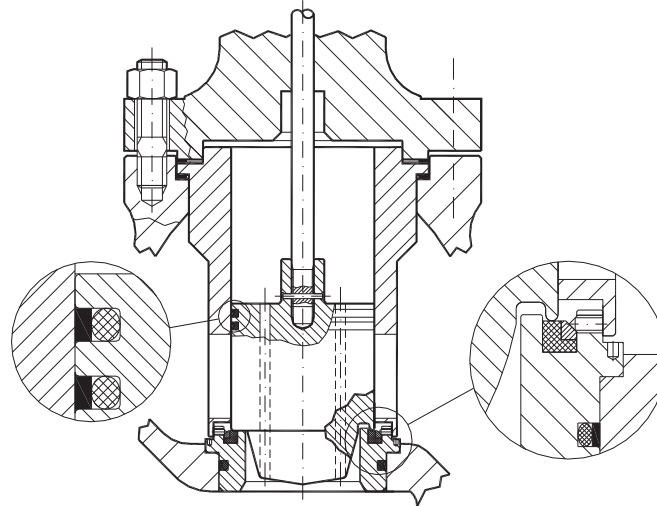

Fig. 13 Quick change seat, soft seat insert, Balanced trim

TECNOIL VALVE Model PC/L – DESIGN Cv Values

Flow Coefficient Cv

The Cv values detailed in the table are at the maximum rated valve travel.

Valve Size		Travel	Cv *											
inches	mm	mm	ANSI 150-600				ANSI 900-1500				ANSI 2500			
1	25	25	14.5	10	5	3	13	9	5	2.5	9	5	3	-
1 ½	40	25	30	24	14.5	10	25	20	13	9	16	13	9	5
2	50	25	55	30	24	14.5	50	25	20	13	32	16	13	9
3	80	40	120	85	55	30	102	72	50	25	70	50	32	16
4	100	50	210	120	85	55	175	102	72	50	110	70	50	32
6	150	60	440	325	210	120	362	267	175	102	240	180	110	70
8	200	80	700	440	325	210	555	362	267	175	375	240	180	110
10	250	100	1100	700	440	325	850	555	362	267	595	375	240	180
12	300	100	1450	1100	700	440	1000	850	555	362	810	595	375	240
14	350	130	2050	1450	1100	700	1270	1000	870	555	-	-	-	-
16	400	130	2450	2050	1450	1100	1850	1270	1000	870	-	-	-	-
18	450	150	3250	2450	2050	1450	2000	1850	1270	1000	-	-	-	-
20	500	170	3800	3370	2600	2050	2800	2300	1900	1580	-	-	-	-
24	600	200	5400	4500	3800	3370	4500	3800	3370	2600	-	-	-	-

* Values for specific customer applications can be designed into the valve - consult factory

SEAT LEAKAGE

Seat leakage rates are normally measured in accordance with the ANSI/FCI 70-2 specification, using the leakage class designation. The following table defines the achievable leakage class with the plug/seat design available in the Model PC/L.

American National Standard Control valve seat leakage ANSI/FCI 70-2		
Leakage class	Valve type	Maximum seat leakage.
Class IV	Single seat control valve with metal to metal seats.	0,01% of rated valve capacity.
Class V	Single seat control valve with metal to metal seats having exceptional seat tightness or resilient seat dependant on application.	0,0005 ml/min per inch of orifice diameter per psi differential.
Class VI	Single seat control valve with resilient seating.	Bubble "tight".

TECNOIL VALVE Model PC/L - DIMENSIONS

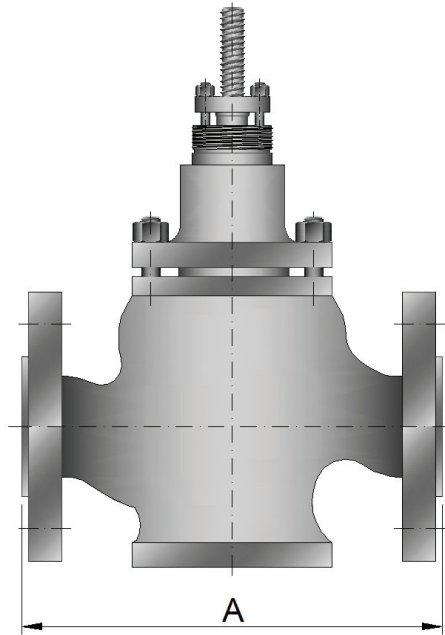

Fig. 14 Face to face dimensions

Valve size		A (mm) - Face to Face											
inches	mm	ANSI 150		ANSI 300		ANSI 600		ANSI 900		ANSI 1500		ANSI 2500	
		RF	RJ	RF	RJ	RF	RJ	RF	RJ	RF	RJ	RF	RJ
1"	25	210	210	210	210	210	210	-	-	308	308	308	308
1 1/2"	40	251	251	251	251	251	251	-	-	384	387	384	387
2"	50	286	289	286	289	286	289	-	-	451	454	451	454
3"	80	318	333	318	340	337	340	381	384	470	473	578	584
4"	100	368	384	368	384	394	397	457	460	546	549	673	683
6"	150	451	464	473	489	508	511	610	613	705	711	914	927
8"	200	543	556	568	584	610	613	737	740	832	842	1022	1038
10"	250	673	686	708	724	752	756	838	841	991	1001	1270	1292
12"	300	737	749	775	790	819	822	965	968	1130	1146	1422	1444
14"	350	876	886	915	928	963	966	1029	1039	1257	1276	-	-
16"	400	1016	1026	1057	1070	1108	1111	1130	1140	1384	1406	-	-
18"	450	1028	1038	1085	1098	1132	1138	1219	1232	1537	1559	-	-
20"	500	1125	1135	1189	1205	1237	1243	1321	1334	1664	1686	-	-
24"	600	1460	1470	1538	1560	1590	1600	1549	1581	1943	1984	-	-

