

Tecnoil Valve Model VP/L Ratings ANSI 150-2500

Application

Tecnoil Valve Model VP/L has been designed to be used in the field of energy and oil/gas for temperatures up to 200°C. A wide range of materials offers a choice to suit the individual application. The smooth body flowpath reduces turbulence, minimising the effects of erosion and noise.

Design Features

- Globe and angle body, cast or forged.
- Screwed-in seat trims or Quick-change.
- Trim type: Cage.
- Inherently characterised trims available in Linear, Equal percentage, Quick opening.
- Both balanced and unbalanced trim designs available with soft seat insert option.

Benefits

- Top-entry servicing with immediate access to plug and seat.
- Reduced inspection and maintenance costs.
- Trims compact and easy to install.
- Excellent flow capacity and control rangeability.
- Low actuating forces required with balanced trim styles.
- Reduces potential erosion and noise problems.



Fig. 1 Tecnoil Valve Model VP/L Globe Valve
8" ANSI 600 with pneumatic actuator

ENGINEERING DATA - TECNOIL VALVE Model VP/L Valves

General

The Model VP/L range of valves has been developed to provide a cost effective, reliable and easily maintained control valve capable of working in rigorous environments.

The quick-change trim provides for easily accessible seat and trim components to minimise fitting and parts replacement times. Stem guided, in both balanced and unbalanced configuration, gives excellent rigidity and resistance to vibrations.

End Connection Sizes/Types:

1 in. (25 mm) – 24 in. (600 mm).
Integral Flanges, Butt or Socket weld ends.
For further information, contact the factory.

Design Standard:

ANSI B16.34.

Valve Body Ratings:

ANSI 150 - ANSI 2500.

Body Configurations:

Globe, Angle.

Body Face to Face Dimensions:

See table page. 8.

Bonnet Styles:

Standard.
For further information, contact the factory.

Standard Bonnet Packing:

Teflon/Chevrons.

Trim type:

Cage.

Inherent Trim Characteristic:

Linear, Equal percentage, Quick opening.

Plug Options:

Balanced, Unbalanced.

Plug/Seat Leakage Class:

Class IV ANSI/FCI 70.2 as standard.

Options:

- Class V
- Class VI with soft seat insert.

Paint:

A wide range of paint finishes are available.

Inspection and Testing:

Inspection & Testing to Tecnoil Valve's standard as well as to almost all international standards / customer's requirements.

Actuation

Various types of actuation are available, including: pneumatic piston and diaphragm spring, direct and reverse action. In addition electric and hydraulic actuators are available.

Instruments:

A wide range of control instruments are available, including: Positioners, Air-filter Regulators, Volume Boosters, Lock-up valves, etc...

Main Materials:

Body / Bonnet:

Material Group or Common Name	Nominal Type	UNS	Forging Spec	Casting Spec. Equivalent	DIN W. No
Carbon steel	C-Mn-Fe	K03504	A105N	A216-WCB A216 WCC	1.0460
Low Temperature Carbon Steel	C-Mn-Fe	K03011	A350-LF2	A352-LCA A352-LCB A352-LCC	1.0566
Low Alloy Steel	1.1/4Cr-1/2Mo	K11572	A182-F11 cl2	A217-WC6	1.7335
	2.1/4Cr-1Mo	K21590	A182-F22 cl3	A217-WC9	1.7380
Stainless steel	304: 18Cr-8Ni	S30400	A182-F304	A351-CF8	1.4301
	304L: 18Cr-8Ni	S30403	A182-F304L	A351-CF3	1.4306
	316: 16Cr-12Ni-2Mo	S31600	A182-F316	A351-CF8M	1.4401
	316L: 16Cr-12Ni-2Mo	S31603	A182-F316L	A351-CF3M	1.4404
	316Ti	S31635	-	-	1.4571
	347: 18Cr-10Ni-Cb(Nb)	S34700	A182-F347	A351-CF8C	1.4550
	22Cr-5Ni-3Mo-N	S31803 S32205	A182-F51	A890-gr4A* A351-CD3MN	1.4462
	25Cr-7Ni-3.5Mo-N-Cu-W	S32760	A182-F55	A995-CD3MWCuN	-
Inconel 625	60Ni-22Cr-9Mo-3.5Cb	N06625	B564-N06625	A494-CW-6MC*	2.4856
-	-	C95800	-	B148-C95800	-

* = no longer referenced in ANSI B16.34 2009

Trim:

- 17-4 PH
- SS 316
- SS 316 + Stellite
- SS 410
- SS 410 + Stellite
- SS 420
- SS 304
- SS 304 + Stellite
- A182 F51
- A182 F53
- AISI 440C
- AL-Bronze
- INCONEL 625
- MONEL

For further information, contact the factory.

VALVE BODY STYLE OPTIONS

The Tecnoil Valve Model CH/L provides two basic body styles: globe and angle. Many parts are interchangeable, with the exception of the valve bodies. The angle type has an optional venturi seat which may be specified in order to provide additional protection to the valve outlet.



Fig. 2 Globe Valve Body with Flanged Connections



Fig. 3 Angle Valve Body with Butt Welded Connections

BONNET AND PACKING OPTIONS

Only forged, usually constructed in the same material as the valve body.

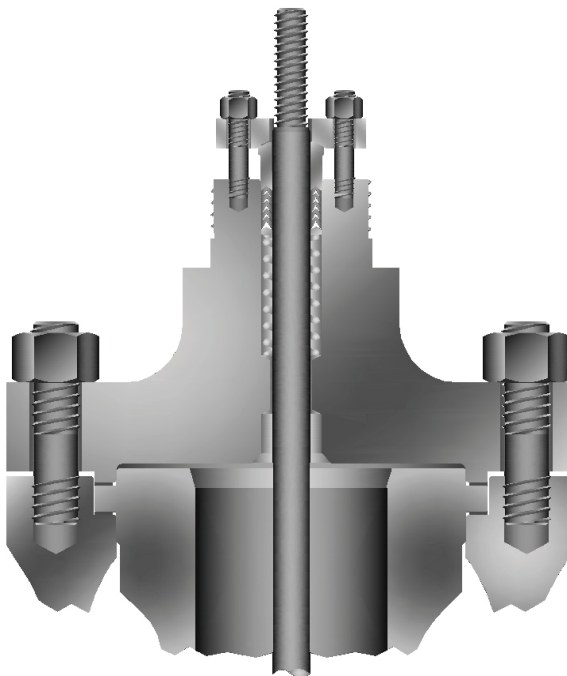

Fig. 4 Standard bonnet

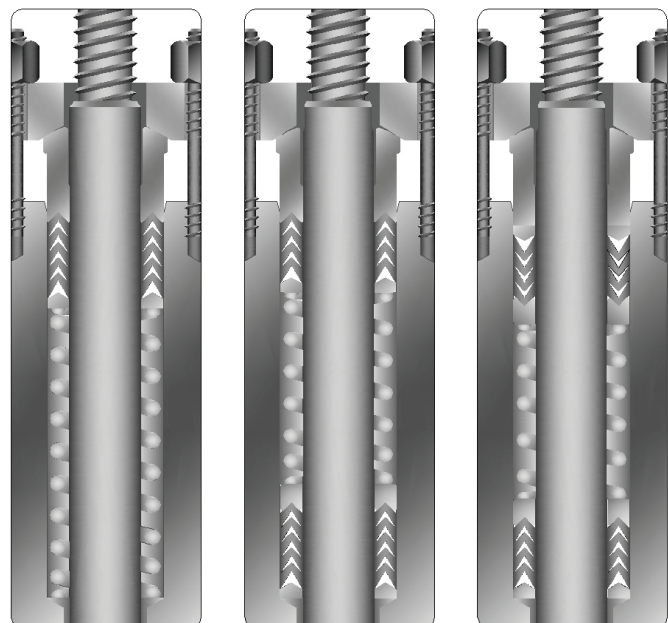

Fig. 5 PTFE Packing Options: Single, Double and Vacuum type

STANDARD TRIM AVAILABLE

Single Cage Trim

Single cage trims are available for high pressure drop applications to prevent the onset of cavitation and to reduce noise levels.

- **Valve Size Options**
Up to 24 in. ANSI 150-2500. For larger sizes consult factory.
- **Plug Options**
Balanced, Unbalanced, metal to metal or soft seat insert.
- **Characteristics Available**
Equal percentage, Linear.
- **Direction of flow**
Either direction, dependent upon application.
- **Hard Trim Options**
Heat hardening.
Stellite coating on seat and/or plug.
- **Soft seating**
Soft seat insert.

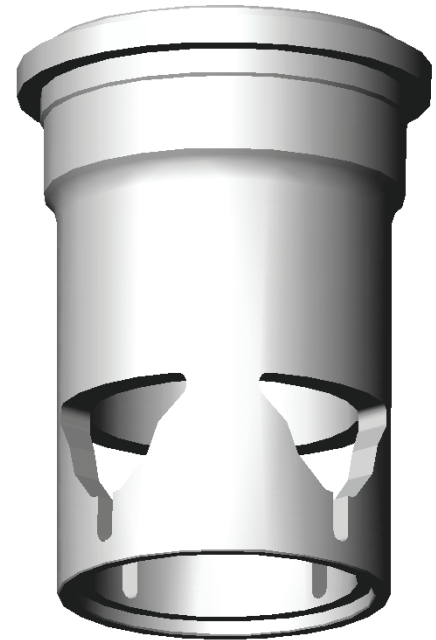

Cage V-Port

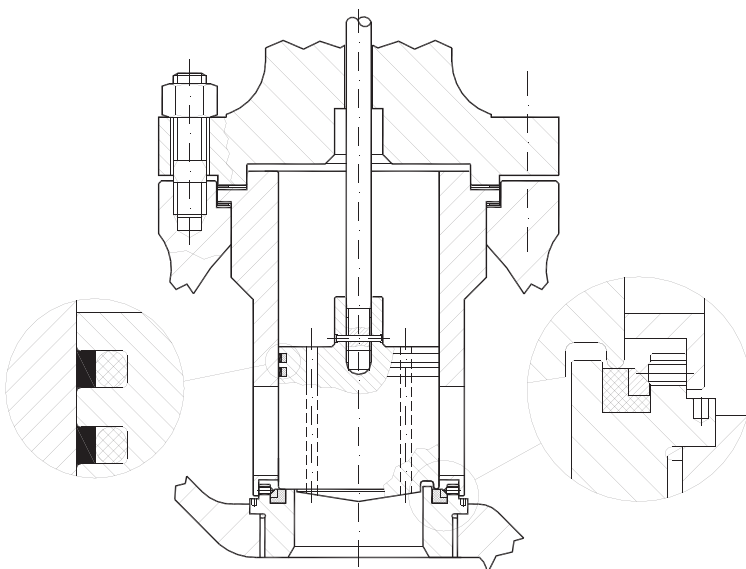

Fig. 6 Threaded seat – Soft seat insert – Balanced trim

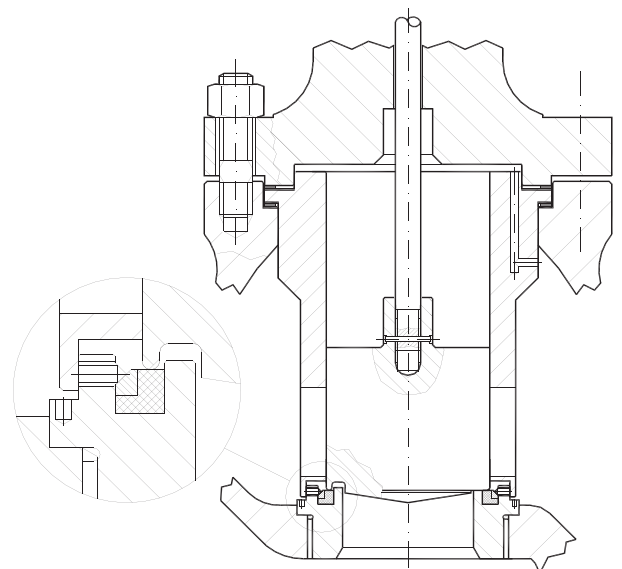

Fig. 7 Threaded seat – Soft seat insert – Unbalanced trim

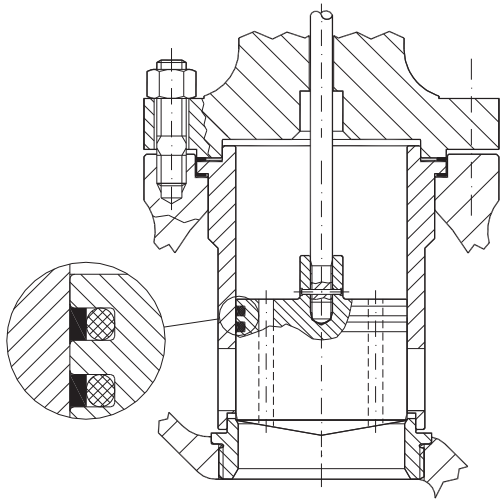

Fig. 8 Threaded seat – Balanced trim

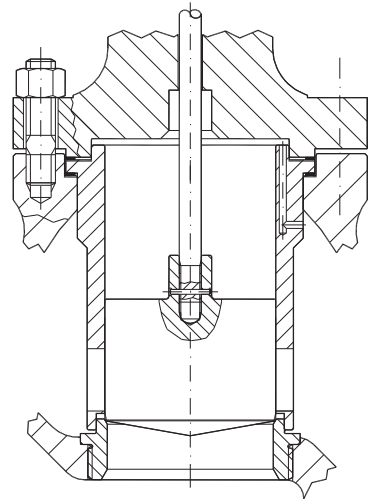

Fig. 9 Threaded seat – Unbalanced trim

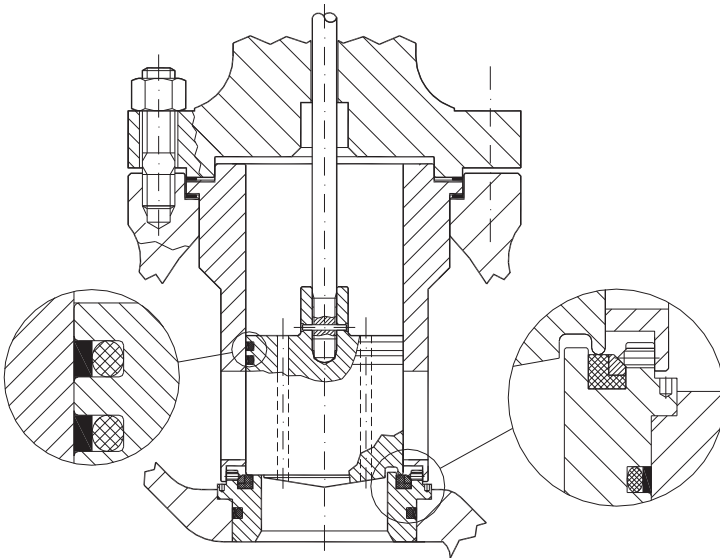

Fig. 10 Quick-change seat – Soft seat insert – Balanced trim

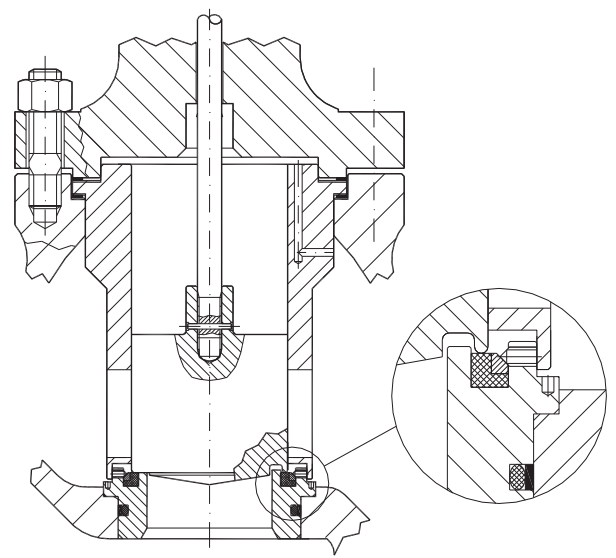

Fig. 11 Quick-change seat – Soft seat insert – Unbalanced trim

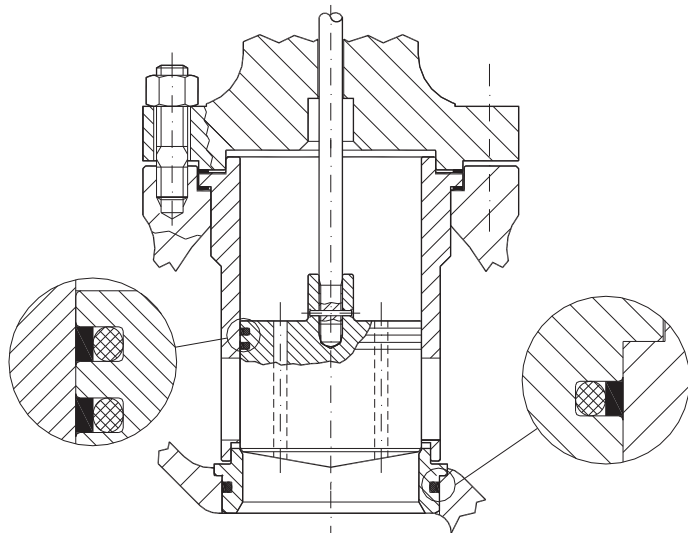

Fig. 12 Quick-change seat - Balanced trim

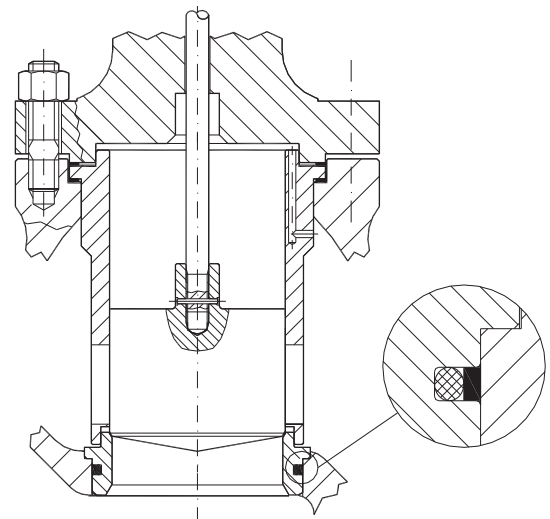

Fig. 13 Quick-change seat – Unbalanced trim

TECNOIL VALVE Model VP/L – DESIGN Cv Values

Flow Coefficient Cv

The Cv values detailed in the table are at the maximum rated valve travel.

Valve size		Travel	Cv*											
inches	mm	mm	ANSI 150 - 600				ANSI 900 - 1500				ANSI 2500			
1"	25	25	10	6,5		-	8	6		-	6	3	-	-
1 1/2"	40	25	22	17	10	6,5	15	11	8	6	10	9	6	3
2"	50	25	50	22	17	10	28	15	11	8	18	10	9	6
3"	80	40	90	62	50	22	65	45	28	15	45	30	18	10
4"	100	50	135	90	62	50	105	65	45	28	70	45	30	18
6"	150	60	270	215	135	90	210	145	105	65	135	100	70	45
8"	200	80	470	270	215	135	330	210	145	105	220	135	100	70
10"	250	100	810	470	270	215	500	330	210	145	350	220	135	100
12"	300	100	1100	810	470	270	660	500	330	210	480	350	220	135
14"	350	130	1450	1100	810	470	915	660	500	330	-	-	-	-
16"	400	130	1800	1450	1100	810	1100	915	660	500	-	-	-	-
18"	450	150	2300	1800	1450	1100	1450	1100	915	660	-	-	-	-
20"	500	170	2900	2300	1800	1450	1890	1450	1100	915	-	-	-	-
24"	600	200	4000	3500	2900	2300	2900	2350	1890	1450	-	-	-	-

* Values for specific customer applications can be designed into the valve - consult factory.

SEAT LEAKAGE

Seat leakage rates are normally measured in accordance with the ANSI/FCI 70-2 specification, using the leakage class designation. The following table defines the achievable leakage class with the plug/seat design available in the Model VP/L.

American National Standard Control valve seat leakage ANSI/FCI 70-2		
Leakage class	Valve type	Maximum seat leakage.
Class IV	Single seat control valve with metal to metal seats.	0,01% of rated valve capacity.
Class V	Single seat control valve with metal to metal seats having exceptional seat tightness or resilient seat dependant on application.	0,0005 ml/min per inch of orifice diameter per psi differential.
Class VI	Single seat control valve with resilient seating.	Bubble "tight".

TECNOIL VALVE Model VP/L - DIMENSIONS

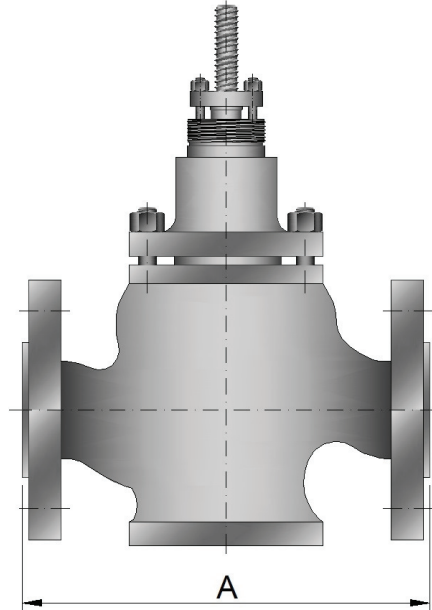

Fig. 14 Face to face dimensions

Valve size		A - Face to Face											
inches	mm	ANSI 150		ANSI 300		ANSI 600		ANSI 900		ANSI 1500		ANSI 2500	
		RF	RJ	RF	RJ	RF	RJ	RF	RJ	RF	RJ	RF	RJ
1"	25	184	197	197	210	210	210	-	-	254	254	308	308
1 1/2"	40	222	235	235	248	251	251	-	-	305	305	384	387
2"	50	254	267	267	283	286	289	-	-	368	371	451	454
3"	80	298	311	318	334	337	340	381	384	470	473	578	584
4"	100	352	365	368	384	394	397	457	460	546	549	673	683
6"	150	451	464	473	489	508	511	610	613	705	711	914	927
8"	200	543	556	568	584	610	613	737	740	832	842	1022	1038
10"	250	673	686	708	724	752	755	838	841	991	1001	1270	1292
12"	300	737	750	775	791	819	822	965	968	1130	1146	1422	1444
14"	350	889	902	927	943	972	975	1029	1039	1257	1276	-	-
16"	400	1016	1029	1057	1073	1108	1111	1130	1140	1384	1406	-	-
18"	450	1096	1109	1143	1159	1202	1205	1219	1232	1537	1559	-	-
20"	500	1202	1215	1254	1273	1318	1324	1321	1334	1664	1686	-	-
24"	600	1416	1429	1475	1497	1550	1560	1549	1568	1943	1971	-	-

