

8 Channel Sensor Signal Amplifier Type Rot (Standard)

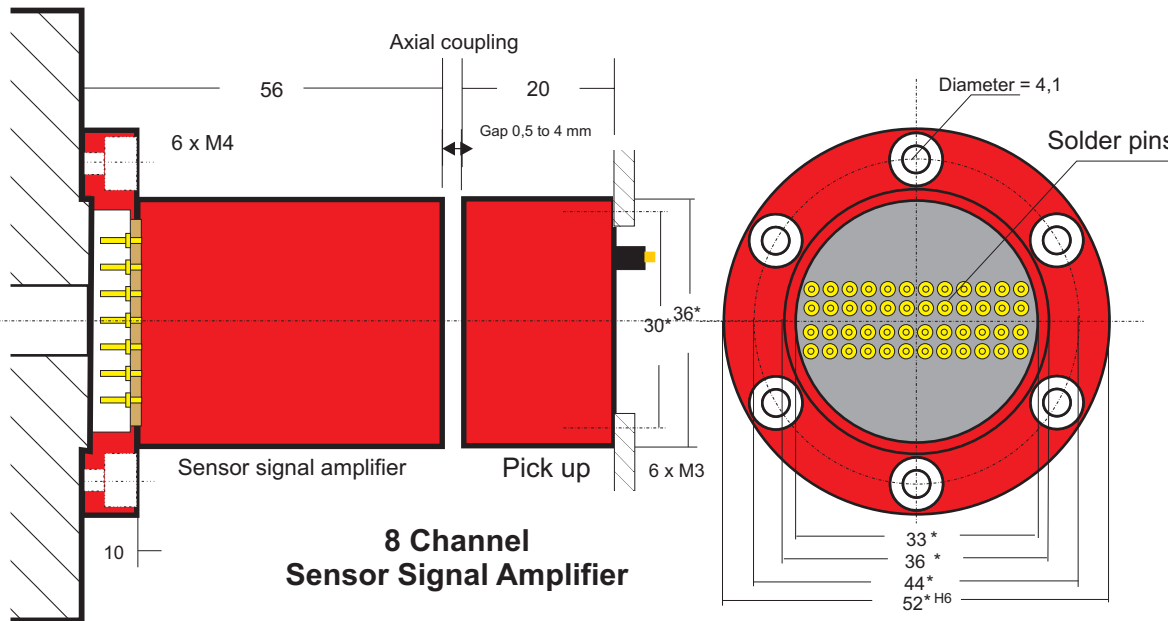

Shaft

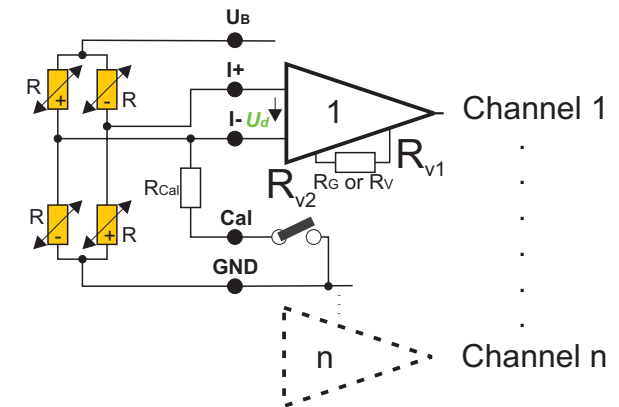

Multi Channel FM/PCM Transmitter

For strain gage, PT100, thermocouple

Number of channels: 2, 4, 8, 12, 16, (max. 128)

Sensitivity: 0,02 mV/V to 20 mV/V

Bandwidth: 0 to 50 kHz (-3dB)

Strain gage bridge supply: 2,5 V, (3,3 V*)

Strain gage bridge resistance: 350 (120, 1000) Ω

Transmission: inductive sensortelemetry FM, PCM

Integrated filter

Resolution: 14 Bits, (16 Bits*)

Zero point drift: 0,02, (0,01, 0,003 option)

Remote shunt calibration

Remote gain/zero and autozero with 12 Bits resolution (option)

Environmental temperature range: -25 to +85°C (125°C, 150°C)

Max load: 50 000 g (depending on fixing)

Type: MSV_R_ <channels>_ <accuracy>_ <temp>_ <mod>_ <samplerate>

2	0,02	85	PCM	4000
4	0,01	125	PCM16	8000
8	0,003	150		40000
12				200000
16			FM*	2000
			total samplerate	