

Industrial X-Ray

Oil Molecular Filter (OMF)



Document information

Author: Roland Moser
Document: 50022605
Created: 01. Oct. 2014

Document history

Version	Date	Author	Amendment(s)	Status
1.0	01.10.2014	R. Moser / M. Obi		

Contents

1	Product description	3
2	Operation Parameters	3
3	Charts	4
	3.1 Effect of COMET OMF filter	4
	3.2 Pressure drop chart	4
4	Instructions for Assembly and Operation	5
	4.1 Mounting kit for COMET Coolers	6
5	Maintenance	7
	5.1 Instructions for Maintenance	7
	5.2 Parts for Maintenance	7
6	Outline drawing	8
7	Return of Goods to COMET	8

1 Product description

The oil filter unit OMF has been developed to maintain the quality and dielectric strength of the cooling circuit of COMET bipolar X-Ray tubes. It consists of 2 stages, a molecular sieve to remove moisture from the oil and a particle filter. For the operation of oil cooled X-Ray tubes it is important to maintain the dielectric strength of the oil also during extended operation of the tube. The oil deteriorates when moisture is being absorbed, in particular during filling or in open cooling systems, when the oil decomposes, or by the formation of particles. This may happen by chemical reactions within the oil at the hot anode surface or by the influence of X-Rays.



2 Operation Parameters

Operating pressure, max:	10 bar
Weight:	5.6 kg
Cooling medium	Oil
Cooling medium temperature at inlet, max.	50 °C

3 Charts

3.1 Effect of COMET OMF filter

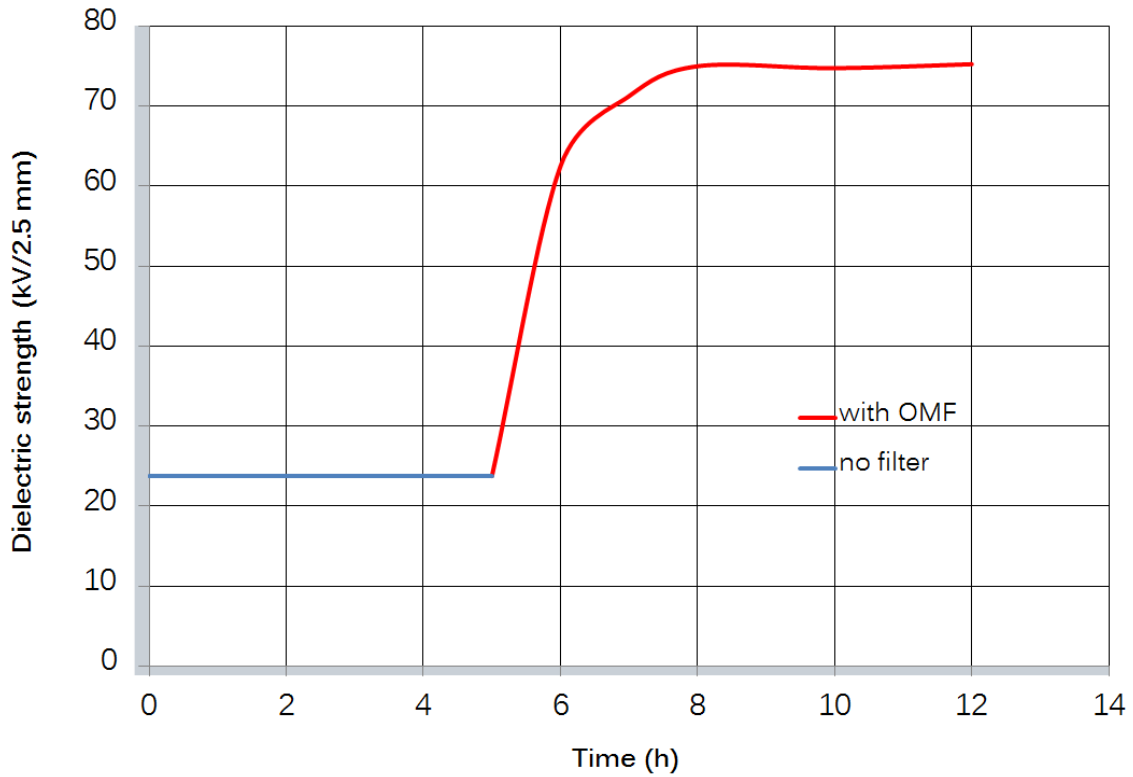

3.2 Pressure drop chart

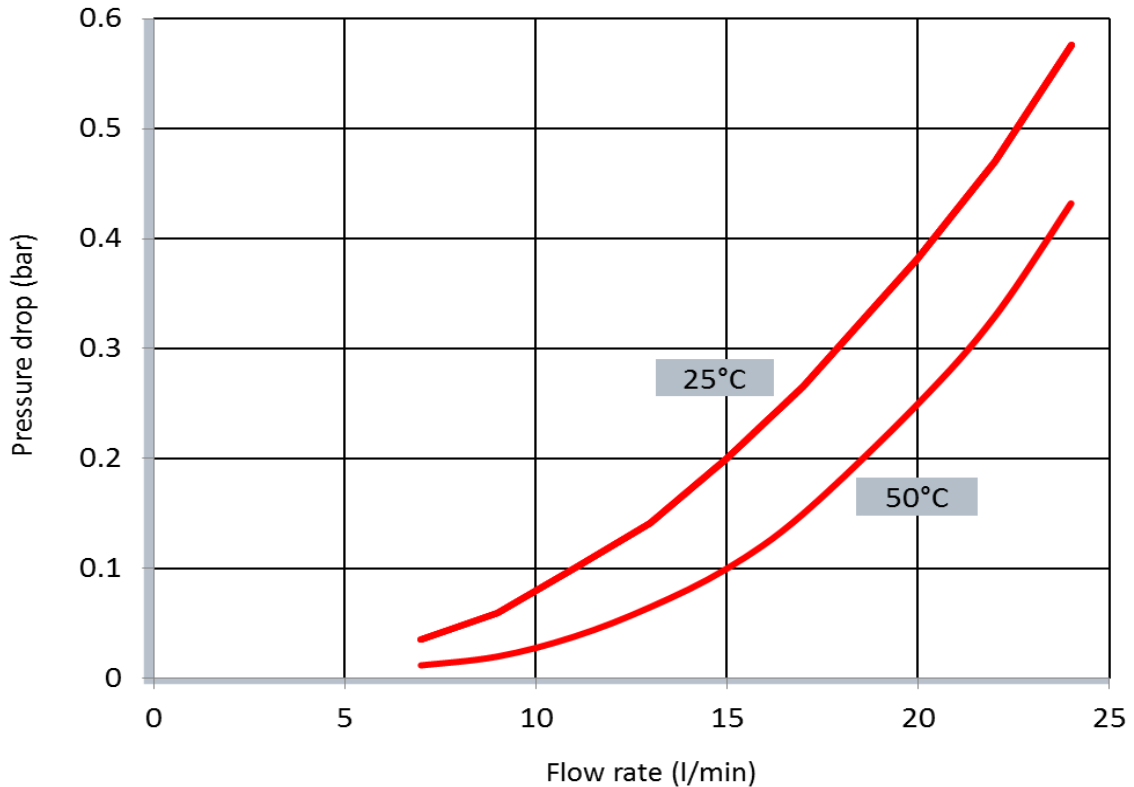

4 Instructions for Assembly and Operation

Oil Molecular Filter OMF (Ord. No. 20073964)

The oil filter unit must be installed in the oil circuit before the oil enters the tube.

Before filling the pellets of the molecular sieve into the filter unit, its upper lid has to be removed by unscrewing the hexagonal head screw. At the bottom of the container for the pellets is a metal sieve which is arrested in its place by a bolt. It is important to control the proper position of the sieve.

The pellets have to be poured into the sieve. One has to avoid pellets falling into the fixation hole in the center of the sieve. The bag with the pellets should be opened only immediately before usage in order to avoid moisture being absorbed by the pellets.

The pellets should be filled almost up to the brim. They must not be squeezed when the lid is closed. Before closing the lid one has to check the seals and replace them in case of physical damage. This is important in order to avoid leaks for the oil, while the pressure in the filter can reach 10 bar. Finally the lid has to be tightened again with the hexagonal screw.

Before starting the X-Ray equipment the cooling circuit has to be filled with oil. It is important to re-move all the air bubbles from the hoses and the filter unit. For this purpose it is recommended to flush the entire circuit with oil for about one hour prior to switch the x-ray ON the first time.

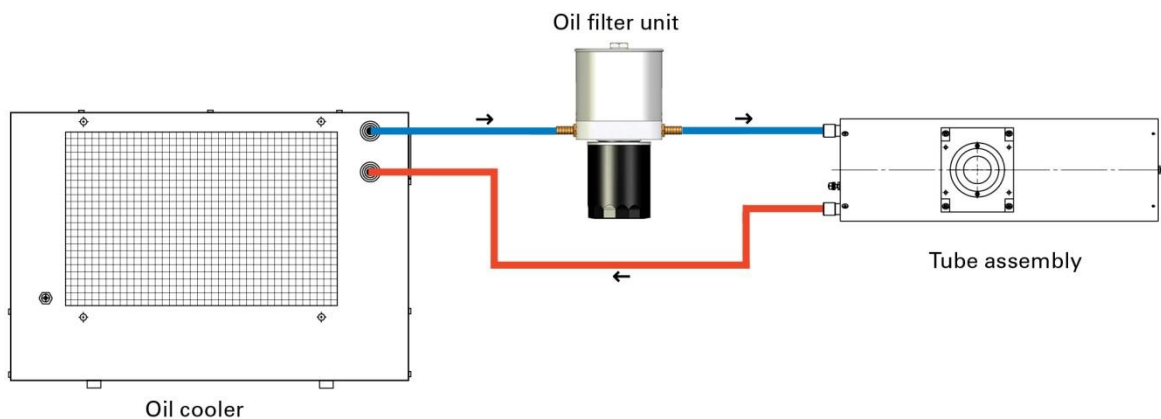

Schematic for the installation of the oil filter unit

4.1 Mounting kit for COMET Coolers

For COMET oil coolers, a specific mounting kit including OMF Filter and connection hose is available.

Mounting kit (Part No. 10009817)

For:
XRC-4501-OA

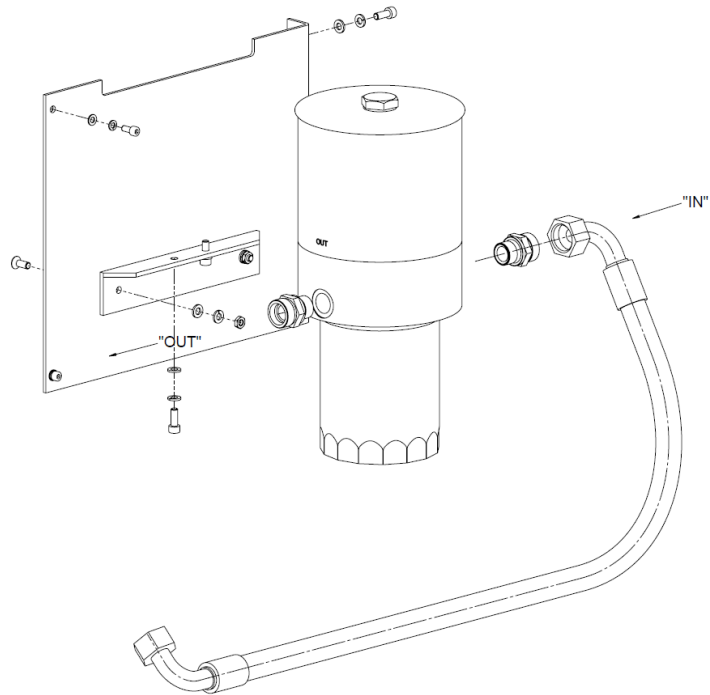

Mounting kit (Part No. 10009818)

For:
XRC-4501-OW
XRCA-5001-OA*

*Additional fixation
holes have to be
drilled into the cooler
cover

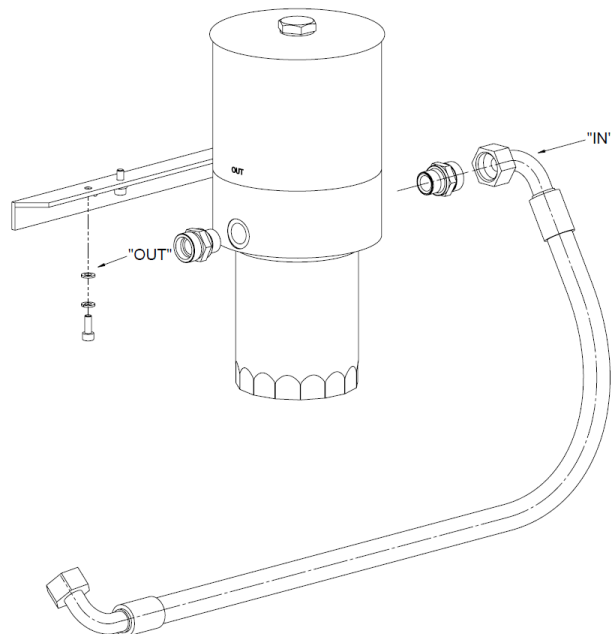

5 Maintenance

5.1 Instructions for Maintenance

The filter unit is maintenance free apart from changing the filter elements at regular intervals. COMET recommends to change the molecular sieve and the oil filter once a year.

With the OMF filter the replacing interval of the oil will be increased from 6 to 36 months or earlier, if the dielectric strength of the oil has dropped to an unacceptable level. (The dielectric strength of the oil should always be above 50 kV/2,5mm)¹. The procedure is the same as described above in the chapter "Instructions for Installation". Replacement parts like the molecular sieve, the oil filter and gaskets can be obtained from COMET.

5.2 Parts for Maintenance

Description	Part No.	
Service kit for OMF	20032933	
Granulate molecular filter for OMF	622219	
Paper filter for OMF	980001	
Oil can, 5 liter, processed Shell Diala S3 ZX-I	4512-101-63583	

¹ EN Standard IEC 60156:1995 / Electrode Type IEC156 Fig.II

6 Outline drawing

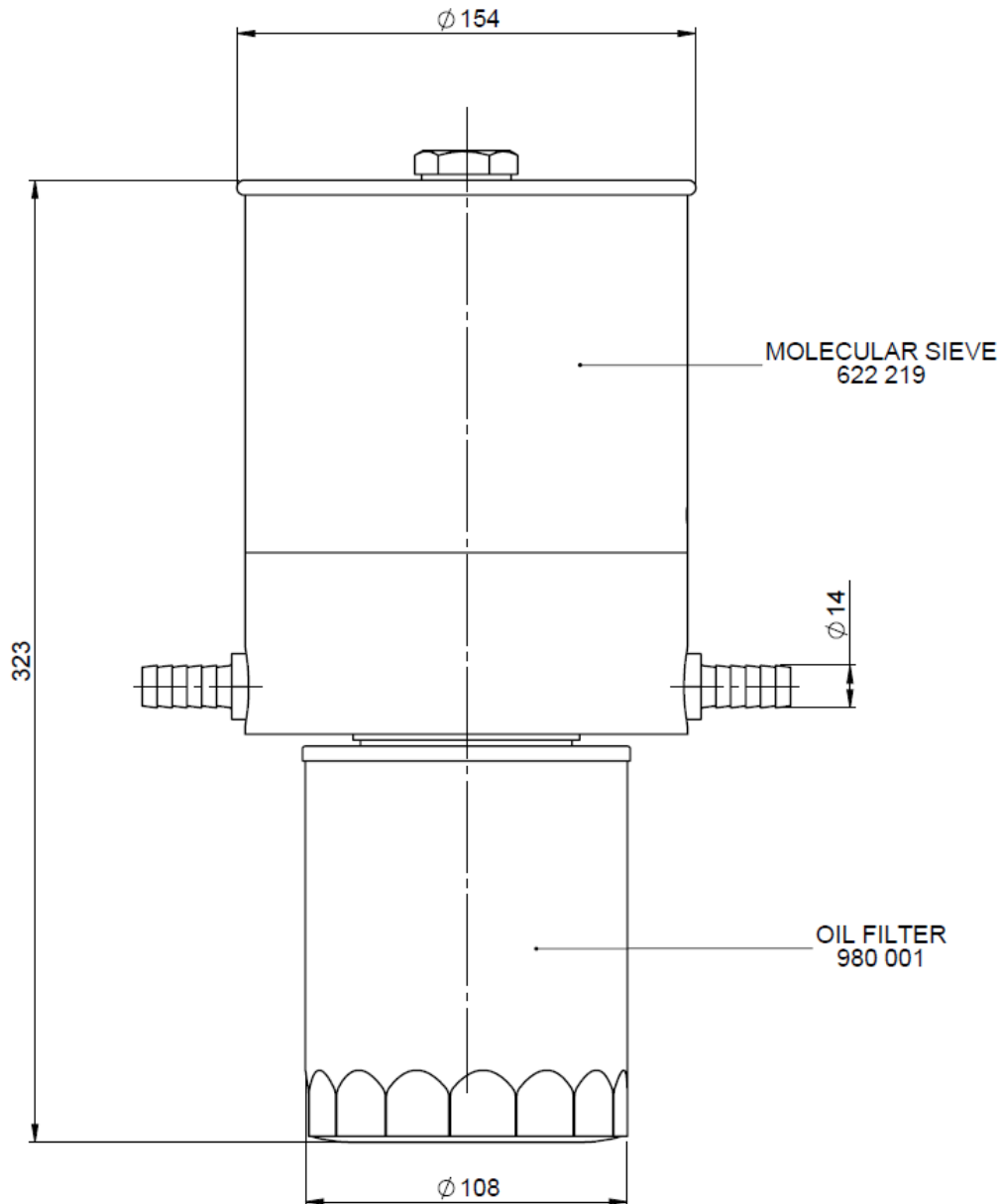

7 Return of Goods to COMET

Prior to shipment to COMET a Field Failure Report (FFR) will be required. The completed FFR has to be added to the shipping documents. The FFR can be downloaded from:

www.comet-xray.com/service