

P20 SERIES CORROSION RESISTANT IN LINE FLOW SWITCH



FEATURES

- Detects flow as low as 140 ml / minute
- No metal parts in contact with the liquid
- All position mounting
- Easy to install
- High flow through
- 18 Bar pressure rating
- Very low head loss

APPLICATIONS

- Liquid or gas flow detection
- Constant pressure pump control
- Loss of prime pump protection
- Water treatment control
- Industrial process control
- Irrigation control
- Chemical dosing systems
- Chilled water control
- Vapour flow detection

DESCRIPTION

The P20 In line Flow Switch is a simple and reliable flow switch that can detect the flow of liquids or gases in tubes and small diameter pipes. The P20 can detect either continuous or pulsed flows. Typical applications include monitoring flow in water treatment and irrigation systems, domestic constant pressure system control, gland cooling systems and a myriad of uses in industrial process control. The P20 flow switch gives a simple on or off response to liquid flow. There are no metal parts in contact with liquids within the switch, so the P20 is ideal for use in aggressive liquids such as seawater, groundwater, acids and many chemical solutions. The standard switch is supplied complete with pipe spigots and unions, for direct fitting into PVC or ABS pipe work. In addition, three electrical modules are available that give a wide choice of control options. Each P20 flow switch is supplied complete with three pistons, to provide the user with a wide choice of flow switching points.

OPERATING PRINCIPLE

The body of the P20 flow switch houses a fluted piston. Any flow, either pulsed or continuous, causes the piston to be pushed back within the switch body to a point where the liquid can pass over the piston and out of the switch. The piston contains a magnet that actuates a reed switch and this provides the switching output. When flow stops, the piston is pushed back to the off position by a second magnet built into the switch body. No metal parts are in contact with the process liquid, and the magnetically sprung piston provides an exceptionally reliable corrosion proof mechanism. The sensitivity of the flow switch and its switching point are determined by the viscosity of the fluid and by the clearance between the piston and the switch body. The P20 flow switch can be mounted in any orientation in pipe work, including upside down, with no adverse effects.

CONSTRUCTION

The standard P20 flow switch is made entirely from glass reinforced polypropylene, with Nitrile O-ring seals. The piston return mechanism and the electrical switching action within the switch are achieved using high power magnets operating through the solid body of the switch. The electrical housing is hose-proof & weatherproof, and is supplied with a built in 20mm cable gland, for conduit or flexible cable entry. The electrical circuit boards used in the switch are interchangeable and all of the parts of the P20 flow switch are available as spare parts.

SWITCH POINT DATA

Switching point and sensitivity to flow depends on liquid velocity, viscosity and piston clearance. To give users as wide a choice as possible, three pistons are supplied with the P20 flow switches. The three pistons allow the choice of a high, low or intermediate range of switching thresholds.

Piston Markings	Switching Point on a Slowly Rising Flow in Litres per Minute	Switching Point on a Slowly Reducing Flow in Litres Per Minute	Electrical Response Time in Seconds
A (Fitted)	0.140	0.065	0.4
B	0.570	0.370	0.3
C	1.70	1.33	0.2

P20 SERIES

ELECTRICAL DATA

The P20 In Line Flow Switch is available in a variety of electrical configurations to suit specific applications. The model numbers and details of these option are outlined in the table below

SWITCH MODEL	MODULE TYPE	CONTACT CONFIGURATION	SWITCHED POWER MAXIMUM	SWITCHED VOLTAGE MAXIMUM	SWITCHED CURRENT RESISTIVE AC (RMS) MAXIMUM	INDUCTIVE LOADS (POWER FACTOR 0.4)	TYPICAL APPLICATION
P20-B	Dry Reed Switch	S.P.S.T N.O	40 Watts	240V AC 200V DC	1 Amp	Not Suitable	PLC and General Control Circuits
P20-C	Dry Reed Switch	S.P.D.T	20 Watts	140V AC 150V DC	1 Amp	Not Suitable	PLC and General Control Circuits
P20-R	Solid State Relay (Triac)	S.P.S.T N.O	740 Watts	2 to 240V AC	4 Amp Continuous (Spike to 15A)	4A at 240V AC 5A at 30V DC	AC Control Circuits and AC Motor Control

ORDERING

P20 - B - 20

ELECTRICAL MODULE

B = S.P.S.T NO REED SWITCH
C = S.P.D.T REED SWITCH
R = S.P.S.T NO SOLID STATE RELAY

PROCESS CONNECTION

(SUITS PVC PIPE)
 20 = 20NB

DIMENSIONS

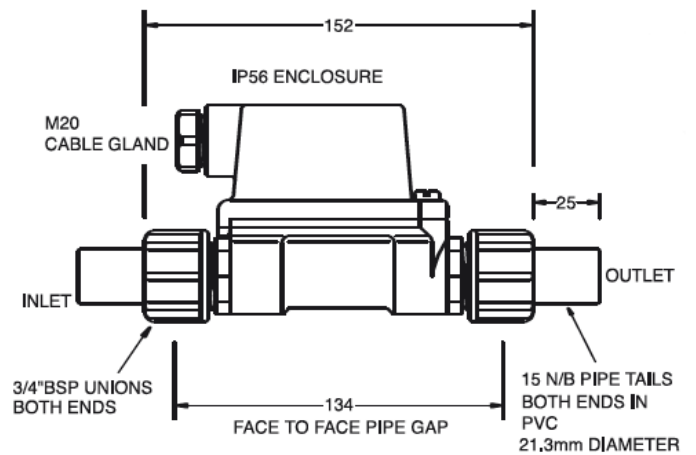

The graph below sets out the dynamic head loss across the P20 flow switch. The graph data refers to water at 15°C as a test medium.

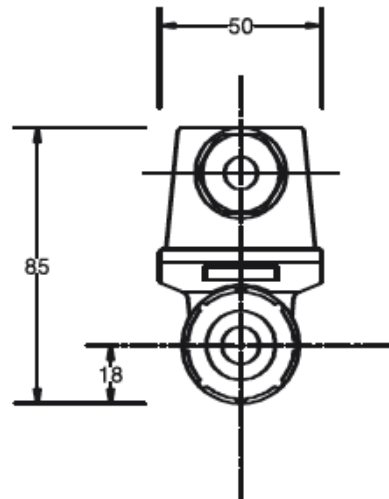
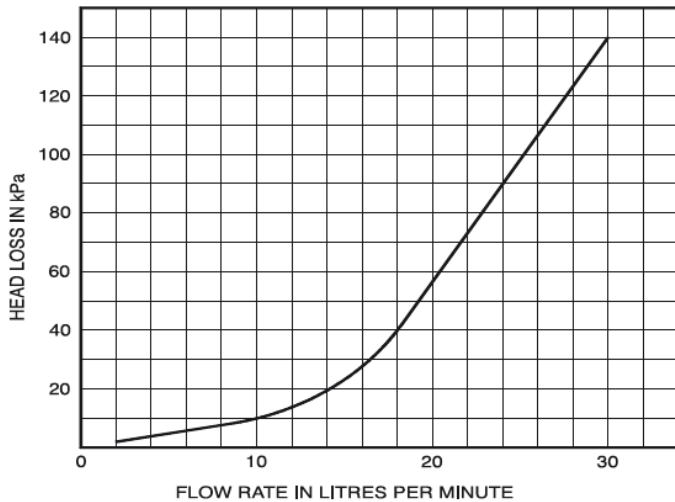

KELCO Engineering Pty Ltd

ABN 20 002 834 844 Head office and factory: 9/9 Powells Road Brookvale NSW 2100 Australia. Postal Address: PO Box 7485 Warringah Mall Post Shop Brookvale NSW 2100 Australia. Phone: +61 2 9905 6425 Fax: +61 2 9905 6420 Email: Sales@kelco.com.au Web: www.Kelco.com.au

PLEASE NOTE: Kelco Engineering Pty Ltd reserves the right to change the specification of this product without notice. Kelco Engineering Pty Ltd accepts no liability for personal injury or economic loss as a consequence of the use of this product. All rights reserved copyright Kelco Engineering Pty Ltd © 2014 The Kelco P20 In Line Flow Switch is protected by a 12 month return to base warranty. Full details of our warranty can be downloaded from: <http://www.kelco.com.au/warranty>