

POSITAL

FRABA

POSITION AND MOTION SENSORS



FRABA WORLDWIDE

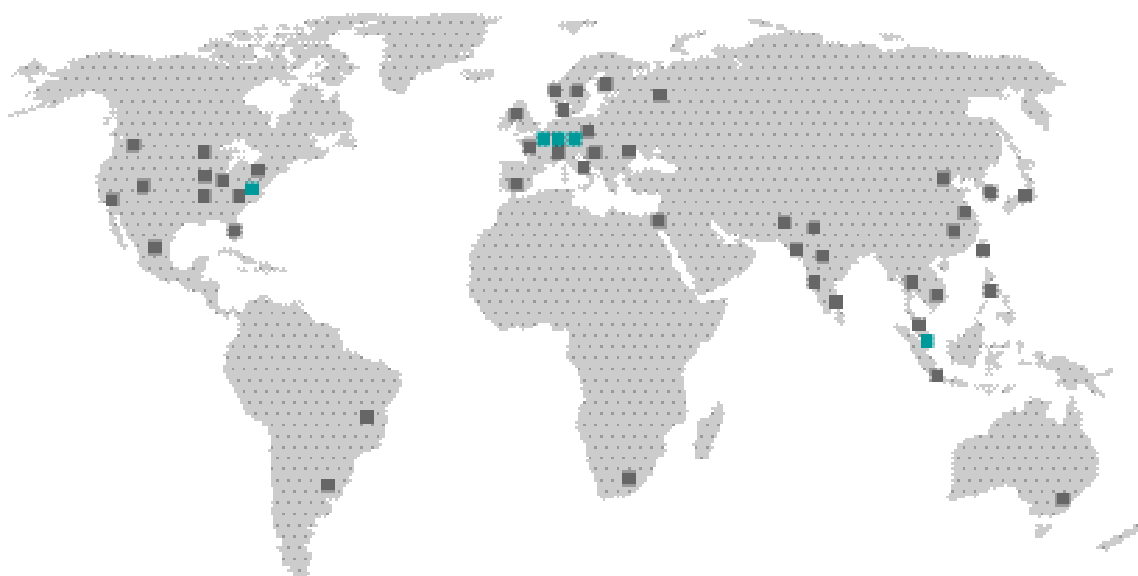

➤ FRABA Group Located in

America

FRABA Inc.
Hamilton, NJ, USA

Asia

FRABA Pte. Ltd.
Singapore

Europe

FRABA AG
Cologne, Germany

R&D Center

CENTITECH GmbH
Aachen, Germany

Manufacturing

CONISTICS Sp. z o.o.
Slubice, Poland

CONISTICS Inc.

Hamilton, NJ, USA

Holding

FRABA B.V.
Heerlen, The Netherlands

➤ POSITAL Sales Partners Located in

America

Argentina
Brazil
Canada
Mexico
USA

Asia

China
India
Indonesia
Israel
Japan
Malaysia
Pakistan
Philippines
Russia
Singapore
South Korea
Taiwan
Thailand

Europe

Austria
Belarus
Czech Republic
Denmark
Finland
France
Germany
Italy
Netherlands, The
Norway
Poland
Slovakia
Spain
Sweden
Switzerland
Ukraine
United Kingdom

Africa

Australia



Please refer to our website for partner contacts in all countries as the list is constantly growing.

COMPANY

Over 50 Years Experience with Position Sensors



FRABA Group

FRABA is a group of enterprises focused on providing advanced products for the motion control and industrial automation markets. POSITAL has been a leading manufacturer of absolute rotary encoders for over 50 years and recently has expanded its business to include tilt and linear motion sensors. Other FRABA Group subsidiaries include VITECTOR which focuses on protection sensors to guard doors and production machine covers.

History

FRABA was founded by Franz Baumgartner in 1918. Until the 1960s, FRABA's main product was mechanical relays. In 1963 FRABA started selling "brush" absolute encoders and in 1973, one of the first non-contact, optical absolute rotary encoders was produced in the FRABA offices in Cologne. Today, FRABA companies specialize in innovative products that use advanced technologies to deliver exceptional performance and value.

Service

Absolute rotary encoders are sophisticated devices that can help solve a wide range of technical problems. However, realizing the full potential of these products may require specialized knowledge when selecting the device configuration and programming the operating parameters. To ensure that customers get what they need, POSITAL's development engineers in Europe, North America and Asia have direct responsibility for customer support. In addition, a growing global network of sales partners is providing expert guidance with knowledge about the local requirements.

Production

POSITAL products are manufactured in advanced production facilities. The computer-guided semi-automated production system tracks each device from order, through assembly and testing, to final delivery. Even with thousands of unique configurations available, standard products are ready to ship within five working days of receiving an order.



CONTENT

Catalog Overview

> POSITAL Products

Rotary Encoders, Linear Sensor and Inclinometers	5
Accessories	5

> Industries

Power Generation and Water	6
Material Handling	7
Mobile Machinery	8
Factory Automation	9
Healthcare and Elevators	10

> IXARC Rotary Encoders

Technology Magnetic Encoder	12
Technology Optical Encoder	13
Absolute vs Incremental Encoders	14
Product Overview	15
Product Selection Guide	21

> LINARIX Linear Sensors

Draw Wire Technology Linear Sensor	30
Product Overview	31
Product Selection Guide	33

> TILTIX Inclinometers

Technology Inclinometer	38
Product Overview	39
Product Selection Guide	41

> Accessories

Mounting Fixtures	44
Connectors and Cables	45

> Glossary	46
------------	----

> Notes	47
---------	----

Disclaimer

© FRABA B.V. all rights reserved. We do not assume responsibility for technical inaccuracies or omissions. Specifications are subject to change without notice.

Version 20140815

PRODUCTS

Position and Motion Sensors



High Precision IXARC Rotary Encoders

Motion control applications – ranging from factory automation to mobile machinery – require accurate, realtime information about the location of mechanical components. The IXARC line of absolute rotary encoders provide precise and reliable measurement of the angular positions of joints, drive shafts, pulleys, etc... Available electronic connections range from simple analog outputs to sophisticated Fieldbus and Industrial Ethernet interfaces.

- Absolute and Incremental Technology
- Optical and Magnetic Encoders up to 16bit

Compact Industrial TILTIX Inclinometers

Accurate measurement of tilt or inclination is very important for motion control and safety systems. Inclinometers provide single or dual-axis angle measurement in an economical package. Relying on gravity for their measurement, these sensors have no exposed moving parts, resulting in easy installation and high environmental protection.

- High Accuracy of 0.1° and Resolution of 0.01°
- Measurement Range $\pm 80^\circ$ (Dual Axis) or 360° (Single Axis)

Versatile LINARIX Linear Sensors

Many applications require linear motion to be monitored for system control or to ensure safety. With lengths ranging from 1 m to 10 m (3' to 33'), LINARIX draw wire sensors are available in many configurations to meet an application's requirements. Options include a wide variety of outputs (including analog, Fieldbus and Ethernet variants), heavy duty housings and compact designs.

- Absolute Position Measurement with Resolutions up to 2 μm
- Variety of Materials

Wide Selection of Accessories

POSITAL offers a wide variety of accessories that simplify sensor installation. Mating connectors of different styles and lengths ensure proper electrical connections. Using appropriate mounting accessories minimize wear and tear on encoders and help to ensure a long and reliable life cycle. Interface modules and displays are also available to provide users with immediate access to measurements.

- Different Cable Designs and Lengths
- Adapter Flanges for Precise Installation



INDUSTRIES

Power Generation and Water



Wind Energy

IXARC heavy duty absolute and incremental encoders provide precise angle measurement for pitch control systems that dynamically adjust the angle of wind turbine rotor blades. High resolution encoders are also ideal for yaw control ensuring optimal positioning of the nacelle with respect to wind direction.

- Salt Resistant Sensors
- Increased Efficiency in Extreme Environments

Solar Energy

For both photovoltaic systems and concentrated power plants (CSP, CPV), solar tracking systems increase energy efficiency. The compact and accurate IXARC encoders and TILTIX inclinometers are ideal for both single and two axis tracking systems which not only follow the sun from east to west but also have an adjusting elevation system.

- Optimized Solar Panel Orientation
- Position Maintained even after Power Loss

Water / Wastewater

Accurate monitoring of sluice gates for flood control, sewage and power plants, dams or irrigation facilities can be monitored remotely with IXARC rotary encoders and LINARIX linear sensors. The IXARC magnetic rotary encoders are also ideal for precise valve positioning.

- Minimum Maintenance, Increased Reliability
- Easy Remote Control, Variety of Interfaces

Oil and Gas

Whether it's offshore or onshore, an exploration platform or a refinery POSITAL explosion proof IECEx and ATEX certified products can provide accurate positioning and speed monitoring in pipe handling equipment or in blow out preventer (BOP) systems.

- Certified Sensors for Explosive Environments
- Accurate Leveling for Subsea Systems



INDUSTRIES

Material Handling

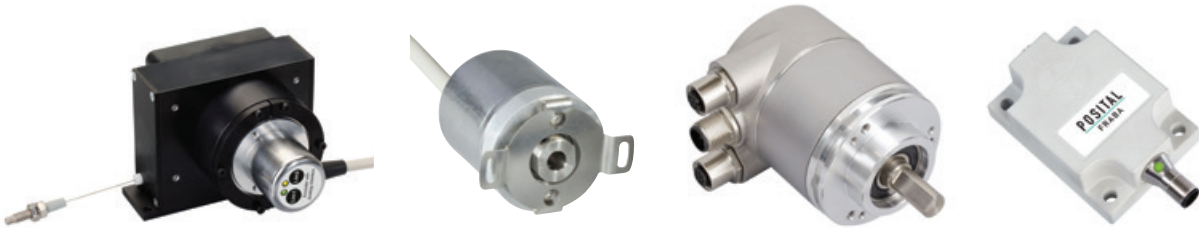

Automated Storage Retrieval Systems

Increasing warehouse and labor costs make the use of automatic storage and retrieval systems economically attractive. IXARC rotary encoders and LINARIX linear sensors are used in these systems to give the position of the loading equipment with respect to the vertical racks where goods are stored.

- Vertical and Horizontal Positioning of the Units
- Accurate Monitoring of the Arms

Overhead Conveyors

Assembly lines for automotive production have dedicated work stations for different processes. Typically the vehicle chassis is moved through a series of such work stations using overhead conveyors. IXARC absolute encoders help achieve this movement in a safe and controlled manner.

- Fieldbus & Ethernet for Fast Communication
- SIL2, SIL3 Certified for Safe Operation

Baggage Handling

Due to stringent security requirements, all airline baggage needs to be screened and distributed in a secure manner. A labyrinth of conveyors helps sort these in a correct fashion. Programmable Fieldbus IXARC rotary encoders help track the position of multiple baggage conveyors.

- Diagnostics LED, Reduced System Installation
- Simplified Wiring, Decreased Time & Costs

Forklifts and Automated Guided Vehicles

For forklifts and AGV's that carry loads from one point to another, safety is of utmost importance. TILTIX inclinometers and LINARIX linear sensors help to avoid accidental contact and insure precise positioning of loads.

- Simple Communication with Analog Interfaces
- Programmable Measurement by the User

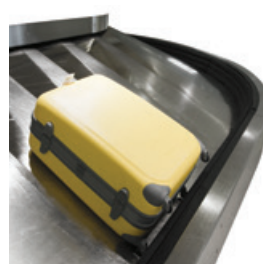

INDUSTRIES

Mobile Machinery



Mining

Drill rigs, excavators and mobile hammering systems are complicated machines which must perform flawlessly under the harshest conditions. For these applications the ATEX certified IXARC rotary encoders can be used to provide precise positioning of drill heads and masts. Single and dual axis POSITAL TILTIX inclinometers further equip operators with essential information for platform leveling and arm positioning.

- Certified Sensors for Explosive Environments
- Precise Positioning & Leveling

Cranes

Cranes and other construction machinery are required to be safe, efficient and reliable. Positioning is of prime importance, and redundant systems are often used to eliminate errors. To address this requirement the IXARC SIL-2 encoders are an excellent fit, combining redundant measurement with an easy-to-integrate interface.

- Sensors for High Levels of Shock & Vibration
- Increased Accuracy & Safety

Arm / Boom Extension

Trucks with long boom extensions such as fire trucks or concrete pumps have to reach to high-rise buildings, often over large obstacles. IXARC rotary encoders can be mounted directly on the rotational joints to provide data for active damping systems. TILTIX single or dual axis inclinometers can be used to monitor the position of the boom arm or for base leveling.

- IP69K Sensors, Pressure & Temperature Resistant
- Easy Communication, CAN & Analog Interfaces

Scissor Lifts and Aerial Work Platforms

Scissor lifts need constant tilt monitoring to prevent tip-overs, an easy job for the dual axis TILTIX inclinometers. IXARC rotary encoders and LINARIX linear sensors are ideal for situations where the height of the lift needs to be known.

- Compact & Economical Sensors
- SIL2, SIL3 Certified for Safe Operation

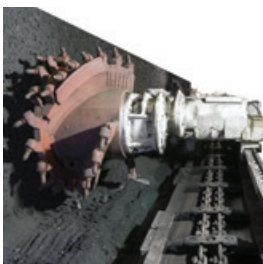

INDUSTRIES

Factory Automation



Packaging

High precision is needed in processes like form filling, sealing, palletizing, pick and place, cartoning and cardboard folding. The IXARC rotary encoders with Fieldbus or Ethernet interfaces can simplify wiring and keep costs down while their stainless steel housing can withstand high temperatures and pressure wash downs.

- > **Precise and Fast Position Feedback**
- > **Reliability at Maximum Work Speed**

Textile and Plastic

In both textile and plastic manufacturing the material used are changed periodically and constant adjustments need to be made in roll and nozzle positioning. IXARC absolute encoders and LINARIX linear sensors can help speed up these changes.

- > **Reduced Downtime and Increased Efficiency**
- > **Reliable Positioning in Hot & Humid Areas**



Food and Beverage

Filling bottles to the right level, accurate labeling and strict regulatory requirements are a few issues that manufactures have to deal with. IXARC rotary encoders and LINARIX linear sensors are used in the food and beverage industry to support efficient and hygienic food packaging.

- > **Stainless Steel Version, Chemical Resistance**
- > **Accurate Process Monitoring**

Industrial Robots

Industrial robots are used widely in manufacturing processes around the world. They carry out activities like welding, painting, assembling which all demand high accuracy. IXARC rotary encoders mounted on the joints of robots can measure and control their movements.

- > **Compact Size, Ideal for Retrofitting**
- > **Absolute & Incremental Measurement**



INDUSTRIES

Healthcare and Elevators



Healthcare

Modern devices used in the healthcare industry demand advanced technology for precise positioning. TILTIX compact inclinometers provide accurate measurements and are built to last the life of the equipment. LINARIX linear sensors offer a solution for tracking the position of patient tables. For more complex applications, such as fluoroscopy or radiography tables or surgical C-arms, that require coordinated positioning of several components, IXARC absolute rotary encoders are an excellent option.

- Precise Positioning of Patient & Scanner
- Simple Installation, Easier Calibration

Elevators

Elevator cars need to be accurately positioned with respect to each floor they visit. IXARC absolute encoders help provide this information without the need of a ground reference. With IXARC absolute encoders, knowledge of the position of the elevator car is always retained, even during power failures. IXARC encoders supporting the CANopen Lift protocol help meet the high safety standards of this industry. Cost efficient LINARIX linear sensors are an excellent solution for door positioning.

- Absolute & Incremental Positioning
- High Shaft Load, Increased Safety



IXARC ROTARY ENCODERS



High Performance Absolute and Incremental Encoders

TECHNOLOGY – IXARC ROTARY ENCODERS

Magnetic Measurement Principles

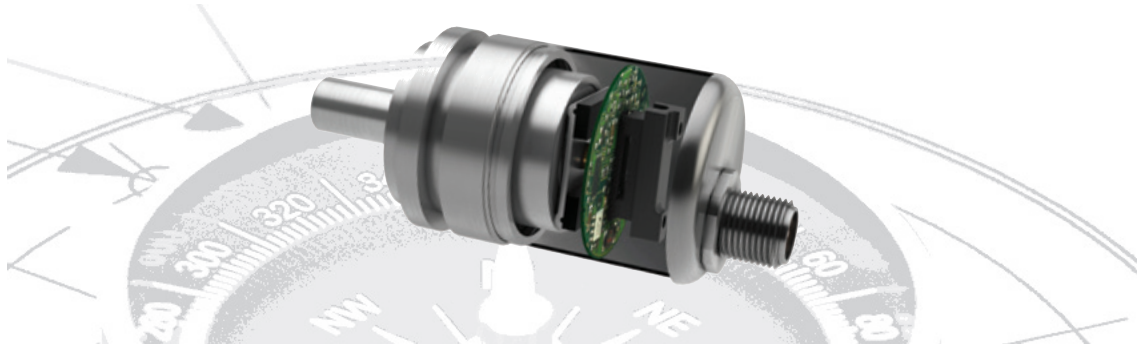

Magnetic rotary encoders determine angular position using magnetic field sensor technology. A permanent magnet **A** fixed to the encoder's shaft creates a magnetic field which is sampled by a sensor **B** that generates an accurate absolute position reading.

Signal Processing is the Key to High Performance

The technological leap that pushes POSITAL's IXARC magnetic encoders to the performance level of optical systems is based on a new generation of sensor systems. The combination of a custom Hall-effect sensor and complex signal processing algorithms running on a powerful 32 bit microprocessor results in a considerably improved resolution and accuracy, along with latency times of only a few microseconds. POSITAL has also implemented an incremental interface and can now offer a complete range of encoder solutions.

Multiturn Innovation

POSITAL can also provide absolute multiturn measurements by means of a revolution counter system

that uses an energy harvesting system based on the Wiegand effect. This system requires no gears or batteries. Eliminating batteries brings about many advantages. Batteries have a limited lifespan, weigh a lot, and often contain harmful substances. Gear units have disadvantages of their own being large, complex, costly and vulnerable to shock and vibration. Regardless of the rotational speed, even at near-zero, the energy harvesting system generates short, powerful voltage pulses, sufficient to power the counting electronics. The result is a revolution counter that is independent of any external power supply. This technology, which has proven itself since 2005, enables maintenance-free reliable measurement of absolute positions, even in demanding environments, for years to come.

Advantages of Magnetic Encoders

- Robust and durable
- Mechanically simple and economical – no battery, no gear
- Compact design for installation in small spaces

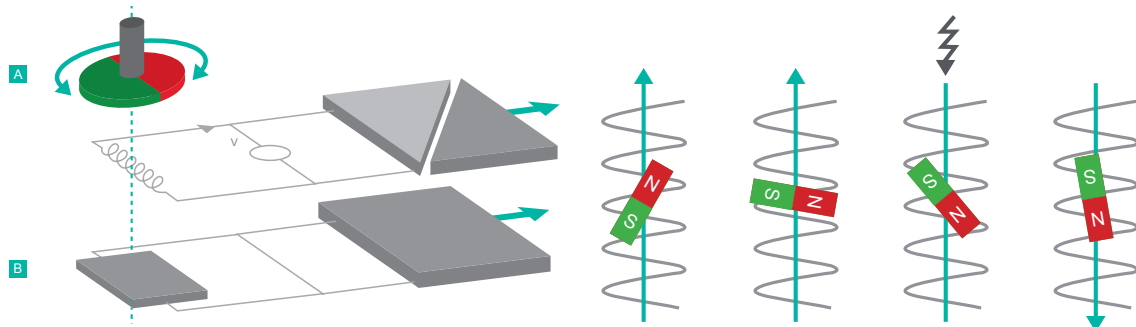

TECHNOLOGY – IXARC ROTARY ENCODERS

Optical Measurement Principles

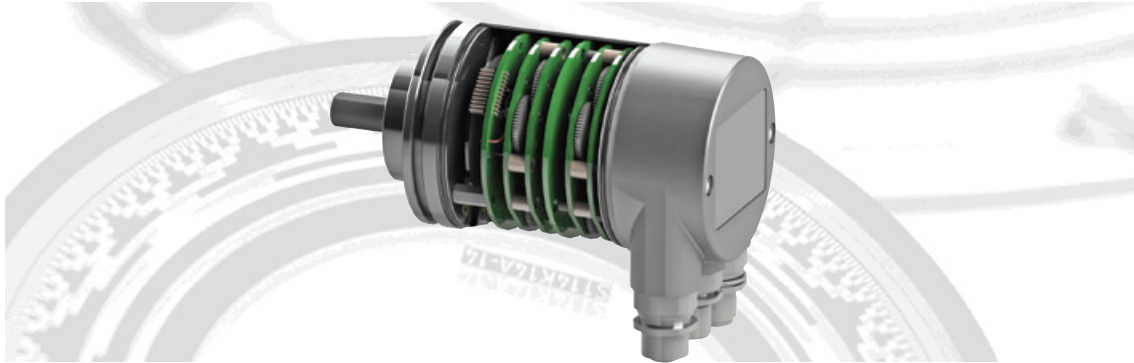

A key component of optical rotary encoders is a code disk **A** mounted on the encoder shaft **B**. This disk is made of unbreakable plastic that has a concentric pattern of transparent and opaque areas. Infrared light from an LED **C** shines through the code disk, onto an array of photoreceptors **D**. As the shaft turns, a unique combination of photoreceptors are illuminated or blocked from light by the pattern on the disk. For multiturn models, there is an additional set of code discs arranged in a gear train **E**. As the main encoder shaft rotates, these discs are geared together to turn like the wheels of an odometer. The rotational position of each disc is monitored optically and the output is a count of the net number of rotations of the encoder shaft.

by the mechanically geared code disks to as many as 16,384 (2^{14}) revolutions.

Advantages of Optical Encoders

- High resolution and accuracy along with excellent dynamic response
- For use in areas with high magnetic fields
- No risk of these devices losing track of their absolute position
- No backup batteries required

Functionality

POSITAL's IXARC optical absolute rotary encoders use highly integrated Opto-ASICs, providing a resolution up to 16 bits (65,536 steps) per turn. For multiturn models, the measuring range is extended

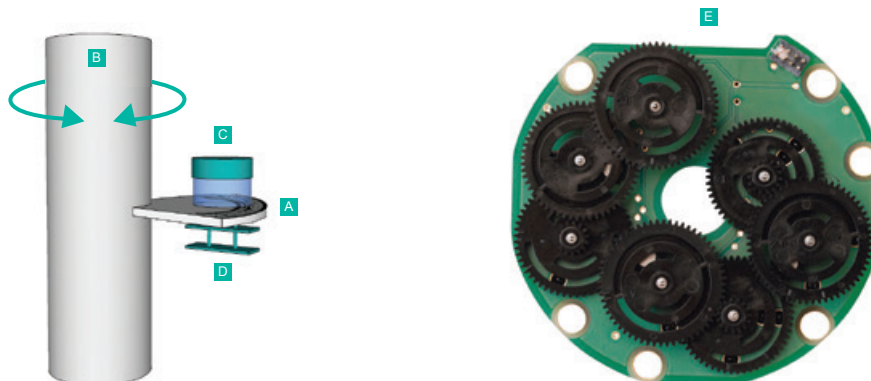

TECHNOLOGY – IXARC ROTARY ENCODERS

Absolute vs Incremental Rotary Encoders



Absolute Rotary Encoders

Absolute rotary encoders are capable of providing unique position values from the moment they are switched on. This is accomplished by detecting the position of a coded element. All positions in these systems correspond to a unique code. Even movements that occur while the system is without power are translated into accurate position values once the encoder is powered up again.

Advantages

- Multiple Interface Options: Analog, Ethernet, Fieldbus, Parallel, Serial
- Singleturn and Multiturn Revolution
- Resolution up to 16 bit
- Optical and Magnetic Measuring Principle

Incremental Rotary Encoders

Incremental encoders generate an output signal each time the shaft rotates a certain amount. (The number of pulses per turn defines the resolution of the device.) Each time the encoder is powered on it begins counting from zero, regardless of where the shaft is. Initial homing to a reference point is therefore inevitable in all positioning tasks, both upon start up of the control system and whenever power to the encoder has been interrupted.





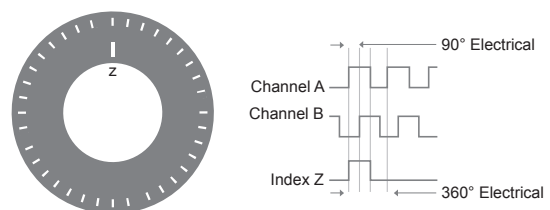
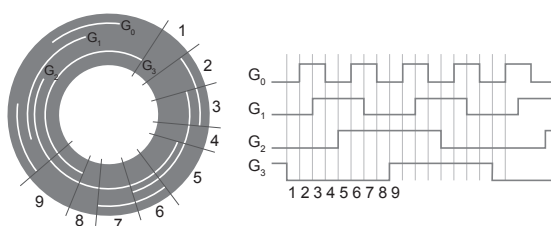

Advantages

- A, B, Z, and Inverted Signals as HTL (Push-Pull) or TTL (RS422).
- Any Pulse Count up to 16384 Pulses per Revolution Available
- Flexible Scaling Functionality
- Magnetic Measuring Principle



PRODUCT OVERVIEW – IXARC ROTARY ENCODERS

Incremental Interfaces

CE		Max. Protection Class	Pulses per Revolution	Accuracy (INL)	Accuracy (DNL)	Flange Size in mm [in]	Clamp Flange	Synchro Flange	Hollow Flange	Square Flange	Supply Voltage in V	Cable	Connector	Connection Cap	Shock / Vibration ¹⁾ in g	Max. RPM	Radial Shaft Load in N
	<ul style="list-style-type: none"> > Magnetic > Incremental > RS422 	IP69K	Up to 16384	0.1°	0.003°	42 [1.65]	■				8-30	■	■		300	6000	300
	<ul style="list-style-type: none"> > Magnetic > Incremental > Push-Pull 	IP69K	Up to 16384	0.1°	0.003°	36 [1.42]	■				4.75-30	■	■		300	6000	180
	<ul style="list-style-type: none"> > Magnetic > Incremental > RS422 	IP67	Up to 16384	0.1°	0.003°	36 [1.42] 58 [2.28]	■	■	■	■	4.75-5.5	■	■		100	12000	110
	<ul style="list-style-type: none"> > Magnetic > Incremental > RS422 	IP67	Up to 16384	0.1°	0.003°	36 [1.42] 58 [2.28]	■	■	■	■	4.75-5.5	■	■		100	12000	110
	<ul style="list-style-type: none"> > Magnetic > Incremental > Push-Pull 	IP67	Up to 16384	0.1°	0.003°	36 [1.42] 58 [2.28]	■	■	■	■	4.75-30	■	■		100	12000	110
	<ul style="list-style-type: none"> > Magnetic > Incremental > Push-Pull 	IP67	Up to 16384	0.1°	0.003°	36 [1.42] 58 [2.28]	■	■	■	■	4.75-30	■	■		100	12000	110

1) Shock and Vibration Based on (EN 60068-2-27) / (EN 60068-2-6), Operating Temperature: -40 to +85 °C [-40 to +185 °F]



Incremental encoders generate an output signal each time the shaft rotates a certain amount. The number of signals per turn defines the resolution of the device.

> For More Information



Please refer to our website for the full range of our products.







www.posital.com/en/incremental

> Related Industries



PRODUCT OVERVIEW – IXARC ROTARY ENCODERS

Analog and Parallel Interfaces

		Max. Protection Class	Max. Revolutions (Turns)	Max. Resolution in bit	Accuracy / Linearity (±)	Flange Size in mm [in]	Clamp Flange	Synchro Flange	Hollow Flange	Square Flange	Supply Voltage in V	Cable	Connector	Connection Cap	Shock / Vibration ¹⁾ in g	Max. RPM	Radial Shaft Load in N
	CE U _L	IP69K	32768	12	0.35°	42 [1.65]	■				15–30	■	■		300	6000	300
	> Magnetic	IP68			0.05%										30		
	> Analog																
	> Current																
	> Magnetic	IP69K	32768	12	0.35°	42 [1.65]	■				12–30	■	■		300	6000	300
	> Analog	IP68			0.05%										30		
	> Voltage																
	> Magnetic	IP65	32768	12	0.35°	36 [1.42]	■	■	■	■	12–30	■	■		100	12000	110
	> Analog				0.05%										10		
	> Voltage																
	> Magnetic	IP54	32768	12	0.35°	36 [1.42]	■	■	■	■	12–30	■	■		100	12000	110
	> Prog. Analog				0.05%	58 [2.28]									10		
	> Current																
	> Magnetic	IP54	32768	12	0.35°	36 [1.42]	■	■	■	■	12–30	■	■		100	12000	110
	> Prog. Analog				0.05%	58 [2.28]									10		
	> Voltage																
	> Optical	IP67	16384	16	0.022°	58 [2.28]	■	■	■	■	10–30	■	■		100	12000	110
	> Parallel														10		
	> Binary, Gray																

1) Shock and Vibration Based on (EN 60068-2-27) / (EN 60068-2-6), Operating Temperature: -40 to +85 °C [-40 to +185 °F]

ANALOG A common standard with either a voltage or a current output.

PARALLEL All bits of the position output are transferred simultaneously using one line for each bit.

> For More Information



Please refer to our website for the full range of our products.







www.posital.com/en/analogparallel

> Related Industries



PRODUCT OVERVIEW – IXARC ROTARY ENCODERS

SSI Interfaces

		Max. Protection Class	Max. Revolutions (Turns)	Max. Resolution in bit	Accuracy / Linearity (±)	Flange Size in mm [in]	Clamp Flange	Synchro Flange	Hollow Flange	Square Flange	Supply Voltage in V	Cable	Connector	Connection Cap	Shock / Vibration ¹⁾ in g	Max. RPM	Radial Shaft Load in N
	<ul style="list-style-type: none"> > Magnetic > SSI > Up to 16 bit 	IP69K IP68	65536	16	0.1°	42 [1.65]	■				4.75–30	■	■		300 30	6000	300
	<ul style="list-style-type: none"> > Magnetic > SSI > Up to 16 bit 	IP69K IP68	65536	16	0.1°	36 [1.42]	■				4.75–30	■	■		300 30	6000	180
	<ul style="list-style-type: none"> > Magnetic > SSI > Up to 16 bit 	IP65	65536	16	0.1°	36 [1.42] 58 [2.28]	■	■	■		4.75–30	■	■		100 10	12000	110
	<ul style="list-style-type: none"> > Optical > SSI + Increm. > Up to 16 bit 	IP65	16384	16	0.022°	58 [2.28]	■	■	■		4.5–30	■	■		100 10	12000	110
	<ul style="list-style-type: none"> > Optical > SSI > Up to 16 bit 	IP67	16384	16	0.022°	58 [2.28]	■	■	■		4.5–30	■	■		100 10	12000	110
	<ul style="list-style-type: none"> > Optical > SSI > Up to 16 bit 	IP67	16384	16	0.022°	58 [2.28]	■	■	■		4.5–30	■	■		100 10	12000	110

1) Shock and Vibration Based on (EN 60068-2-27) / (EN 60068-2-6), Operating Temperature: -40 to +85 °C [-40 to +185 °F]



SSI is a widely used serial interface with point-to-point connection between PLC/Master and encoder. It is based on the RS422 standard.

> For More Information



Please refer to our website for the full range of our products.





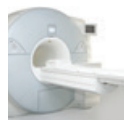



www.posital.com/en/ssi

> Related Industries



PRODUCT OVERVIEW – IXARC ROTARY ENCODERS

Bus Interfaces

	 	Max. Protection Class	Max. Revolutions (Turns)	Max. Resolution in bit	Accuracy / Linearity (±)	Flange Size in mm [in]	Clamp Flange	Synchro Flange	Hollow Flange	Square Flange	Supply Voltage in V	Cable	Connector	Connection Cap	Shock / Vibration ¹⁾ in g	Max. RPM	Radial Shaft Load in N
	<ul style="list-style-type: none"> > Magnetic > CANopen > Up to 16 bit 	IP69K	65536	16	0.35°	42 [1.65]	■				10-30	■	■		300	6000	300
	<ul style="list-style-type: none"> > Magnetic > SAE J1939 > Up to 16 bit 	IP69K	65536	16	0.1°	36 [1.42]	■				10-30	■	■		300	6000	180
	<ul style="list-style-type: none"> > Magnetic > DeviceNet > Up to 16 bit 	IP65	65536	16	0.1°	36 [1.42] 58 [2.28]	■	■	■	■	10-30	■	■		100	12000	110
	<ul style="list-style-type: none"> > Optical > PROFIBUS > Up to 16 bit 	IP67	16384	16	0.022°	58 [2.28]	■	■	■	■	10-30	■	■	■	100	12000	110
	<ul style="list-style-type: none"> > Optical > Interbus > Up to 16 bit 	IP67	16384	16	0.022°	58 [2.28]	■	■	■	■	10-30	■	■	■	100	12000	110
	<ul style="list-style-type: none"> > Optical > CANopen > Up to 16 bit 	IP67	16384	16	0.022°	58 [2.28]	■	■	■	■	10-30	■	■	■	100	12000	110

1) Shock and Vibration Based on (EN 60068-2-27) / (EN 60068-2-6), Operating Temperature: -40 to +85 °C [-40 to +185 °F]



PROFIBUS is available on many PLCs and one of the most common Fieldbus technologies in factory automation and other areas. It is based on RS485.

SAE J1939

SAE J1939 is a Fieldbus standard used for communication by the car and heavy-duty truck industry.



DeviceNet is a Fieldbus system based on CAN networks and CIP protocol, managed by ODVA, widely used in factory automation and available on many PLCs.



CANopen is a Fieldbus protocol using CAN networks and CANopen Lift is a protocol for elevator applications.



Interbus is a Fieldbus technology developed by Phoenix Contact

> For More Information



Please refer to our website for the full range of our products.







www.posital.com/en/bus

> Related Industries



PRODUCT OVERVIEW – IXARC ROTARY ENCODERS

Ethernet Interfaces

		Max. Protection Class	Max. Revolutions (Turns)	Max. Resolution in bit	Accuracy / Linearity (±)	Flange Size in mm [in.]	Clamp Flange	Synchro Flange	Hollow Flange	Square Flange	Supply Voltage in V	Cable Connector	Connection Cap	Shock / Vibration ¹⁾ in g	Max. RPM	Radial Shaft Load in N
	<ul style="list-style-type: none"> > Optical > EtherNet/IP > Up to 16 bit 	IP67	16384	16	0.022°	58 [2.28]	■	■	■	■	10–30	■	■	100	12000	110
	<ul style="list-style-type: none"> > Optical > PROFINET > Up to 16 bit 	IP67	16384	16	0.022°	58 [2.28]	■	■	■	■	10–30	■	■	100	12000	110
	<ul style="list-style-type: none"> > Optical > EtherCAT > Up to 16 bit 	IP67	16384	16	0.022°	58 [2.28]	■	■	■	■	10–30	■	■	100	12000	110
	<ul style="list-style-type: none"> > Optical > Modbus/TCP > Up to 16 bit 	IP67	16384	16	0.022°	58 [2.28]	■	■	■	■	10–30	■	■	100	12000	110
	<ul style="list-style-type: none"> > Optical > POWERLINK > Up to 16 bit 	IP67	16384	16	0.022°	58 [2.28]	■	■	■	■	10–30	■	■	100	12000	110
	<ul style="list-style-type: none"> > Optical > EtherNet/IP > Up to 16 bit 	IP67	16384	16	0.022°	58 [2.28]	■	■	■	■	10–30	■	■	100	12000	110

1) Shock and Vibration Based on (EN 60068-2-27) / (EN 60068-2-6), Operating Temperature: -40 to +85 °C [-40 to +185 °F]



PROFINET is an Industrial Ethernet standard from „PROFIBUS&PROFINET“ International designed for automation.



EtherNet/IP is an communication protocol developed by Rockwell Automation and managed by ODVA.



Modbus is a serial protocol managed by the Modbus Organization.



EtherCAT is an open high performance Ethernet-based Fieldbus system. EtherCAT require short data update times with low communication jitter and low hardware costs.



ETHERNET POWERLINK is a real-time communication system based on Ethernet networks and managed by EPSG.

> For More Information



Please refer to our website for the full range of our products.







www.posital.com/en/ethernet

> Related Industries



PRODUCT OVERVIEW – IXARC ROTARY ENCODERS

ATEX and SIL Certified

		Max. Protection Class	Max. Revolutions (Turns)	Max. Resolution in bit	Accuracy / Linearity (±)	Flange Size in mm [in]	Clamp Flange	Synchro Flange	Hollow Flange	Square Flange	Supply Voltage in V	Cable Connector	Connection Cap	Shock / Vibration ¹⁾ in g	Max. RPM	Radial Shaft Load in N
	<ul style="list-style-type: none"> > Zone 1 & 21 > CANopen > Optical 	IP67	16384	16	0.022°	78 [3.07]	■	■	■	■	10–30		■	100 10	3000	50
	<ul style="list-style-type: none"> > Zone 1 & 21 > PROFIBUS > Optical 	IP67	16384	16	0.022°	78 [3.07]	■	■	■	■	10–30		■	100 10	3000	50
	<ul style="list-style-type: none"> > Zone 1 & 21 > SSI > Optical 	IP67	16384	16	0.022°	78 [3.07]	■	■	■	■	4.5–30		■	100 10	3000	50
	<ul style="list-style-type: none"> > Zone 1 & 21 > Ethernet/IP > Optical 	IP67	16384	16	0.022°	78 [3.07]	■	■	■	■	10–30		■	100 10	3000	50
	<ul style="list-style-type: none"> > Zone 2 & 22 > All Common Interfaces 	IP67	16384	16	0.022°	58 [2.28]	■	■	■		4.5–30	■	■	100 10	12000	110
	<ul style="list-style-type: none"> > Safety Cert. > CANSafe > Optical 	IP67	16384	16	0.022°	58 [2.28]	■	■	■		12–30		■	100 10	6000	110

1) Shock and Vibration Based on (EN 60068-2-27) / (EN 60068-2-6), Operating Temperature: -40 to +85 °C [-40 to +185 °F]

ATEX and IECEx norms define essential requirements for equipment and protective systems intended for use in potentially explosive atmospheres.

SIL (Safety Integrity Level) is defined as a relative level of risk-reduction provided by a safety function in accordance with the requirements of IEC 61508/EN 62061, PL e and Cat.4 according to EN ISO 13849-1

> For More Information



Please refer to our website for the full range of our products.

www.posital.com/en/exproofsafety

> Related Industries



PRODUCT SELECTION GUIDE – IXARC ROTARY ENCODERS

IXARC Incremental Magnetic Encoders

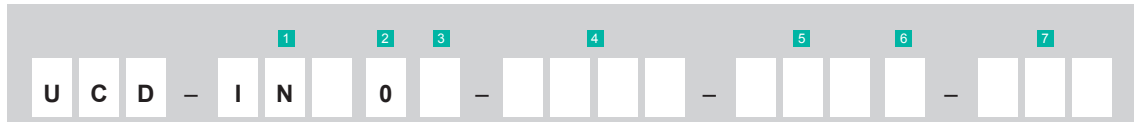

1 Communication Interface

- INR** RS422 (TTL), Supply Voltage 8 – 30 V
- INS** RS422 (TTL), Supply Voltage 4.75 – 5.5 V
- INH** Push-Pull (HTL), Supply Voltage 4.75 – 30 V

2 Pin Assignment

- 0** POSITAL Standard

3 4 Pulses per Revolution

X-XXXX

Choose any pulse count up to 16384

5 Mechanical Design

Please see technical drawings on page 23 – 25

6 Protection Class

- A** IP54
- 0** IP54 to IP65
- S** IP54 to IP67 (Only Clamping Flange)
- D** IP54 to IP69K
- G** IP54 to IP69K (Stainless Steel)

7 Connection Type

- CAW** Cable: Axial 1 m
 - 2AW** Cable: Axial 2 m
 - 5AW** Cable: Axial 5 m
 - AAW** Cable: Axial 10 m
 - CRW** Cable: Radial 1 m
 - 2RW** Cable: Radial 2 m
 - 5RW** Cable: Radial 5 m
 - ARW** Cable: Radial 10 m
 - PAM** Connector: Axial M12 (5 pin)
 - PAQ** Connector: Axial M12 (8 pin)
 - PAL** Connector: Axial M23 (12 pin)
 - PAP** Connector: Axial M23 (16 pin)
 - PRM** Connector: Radial M12 (5 pin)
 - PRQ** Connector: Radial M12 (8 pin)
 - PRL** Connector: Radial M23 (12 pin)
 - PRP** Connector: Radial M23 (16 pin)
- Please see technical drawings on page 23 – 25

> For More Information



Please refer to our website for the full range of our products.

www.posital.com/en/incremental

PRODUCT SELECTION GUIDE – IXARC ROTARY ENCODERS

IXARC Absolute Magnetic Encoders



1 Technology

- M** ≤ 0.36°
U ≤ 0.09° (only available with SSI Interface)

2 Communication Interface

- AV001** Voltage: 0 to 5 V
AVP01 Voltage: 0 to 5 V w. Pushbuttons
AV002 Voltage: 0 to 10 V
AVP02 Voltage: 0 to 10 V w. Pushbuttons
AV003 Voltage: 0.5 to 4.5 V
AVP03 Voltage: 0.5 to 4.5 V w. Pushbuttons
AV004 Voltage: 0.5 to 9.5 V
AVP04 Voltage: 0.5 to 9.5 V w. Pushbuttons
AC005 Current: 4 to 20 mA
ACP05 Current: 4 to 20 mA w. Pushbuttons
AC006 Current: 0 to 20 mA
ACP06 Current: 0 to 20 mA w. Pushbuttons
CA00B CANopen
CL00B CANopen Lift
D200B DeviceNet
C900B J1939
S101B SSI Binary
S101G SSI Gray
S100G SSI Gray (available with technology U)
S100B SSI Binary (available with technology U)

3 Revolution

- 00** Singleturn
04 Multiturn: 4 bit (16 rev)
08 Multiturn: 8 bit (256 rev)
12 Multiturn: 12 bit (4096 rev)
13 Multiturn: 13 bit (8192 rev)
14 Multiturn: 14 bit (16384 rev)
16 Multiturn: 16 bit (65536 rev)
20 Multiturn: 20 bit (1048576 rev)

4 Resolution

- 10** 10 bit (1024 Steps / 0.35°)
12 12 bit (4096 Steps / 0.088°)
13 13 bit (8192 Steps / 0.044°)
14 14 bit (16384 Steps / 0.02°)
16 16 bit (65536 Steps / 0.005°)

5 Mechanical Design

Please see technical drawings on page 23 – 25

6 Protection Class

- A** IP54
0 IP54 to IP65
S IP54 to IP67 (Only Clamping Flange)
D IP54 to IP69K
G IP54 to IP69K (Stainless Steel)

7 Connection Type

- CAW** Cable: Axial 1 m
2AW Cable: Axial 2 m
5AW Cable: Axial 5 m
AAW Cable: Axial 10 m
CRW Cable: Radial 1 m
2RW Cable: Radial 2 m
5RW Cable: Radial 5 m
ARW Cable: Radial 10 m
PAM Connector: Axial M12 (5 pin)
PAQ Connector: Axial M12 (8 pin)
PRM Connector: Radial M12 (5 pin)
PRQ Connector: Radial M12 (8 pin)
 Please see technical drawings on page 23 – 25

► For More Information



Please refer to our website for the full range of our products.

www.posital.com/en/absolutemagnetic

PRODUCT SELECTION GUIDE – IXARC ROTARY ENCODERS

Technical Drawings

> Ø 36 mm Housing

6 IP64, IP65 (Aluminum)

7 Connection Type: Connector and Cable
(Axial and Radial)

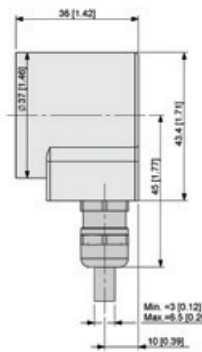
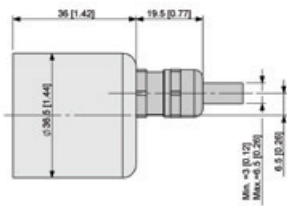

6 IP54 (Aluminum)

7 Connection Type: Grommet Cable
(Axial and Radial)

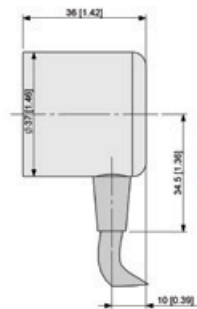
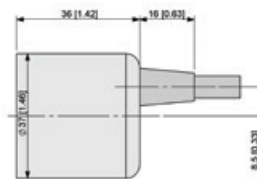

Mechanical Design for Ø 36 mm Housing

Aluminum Flanges

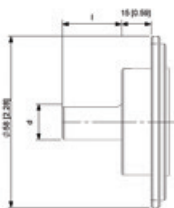

> Ø 58 mm Clamp

	d	l
5 M06	6	6
5 M10	10	10
5 M12	12	12

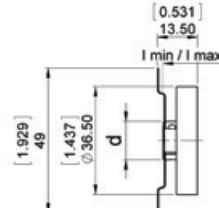

> Ø 36 mm Blind Hollow

	d	l min/max
5 A06	6	11/14

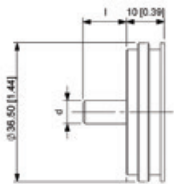

> Ø 36 mm Synchro

	d	l
5 R06	6	10
5 R10	10	12

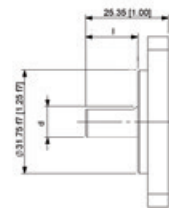

> Ø 2" Square

	d	l
5 3A7	9.52	14

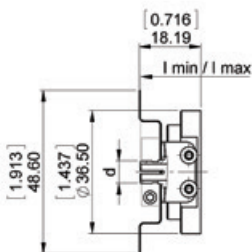

> Ø 36/42 mm Blind Hollow

	d	l min/max
5 V06	6	12/18
5 V08	8	12/18
5 V10	10	12/18
5 V12	12	12/18

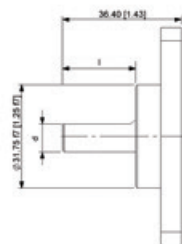

> Ø 2.5" Square

	d	l
5 4A7	9.52	20

PRODUCT SELECTION GUIDE – IXARC ROTARY ENCODERS

Technical Drawings

> Ø 36 mm Housing

- 6 IP68, IP69K (Powder Coated Steel)
- 7 Connection Type: Connector and Cable
(Axial and Radial)

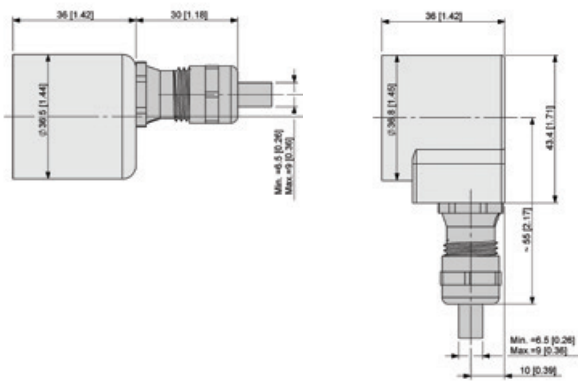

> Ø 42 mm Housing

- 6 IP68, IP69K (Stainless Steel)
- 7 Connection Type: Connector and Cable
(Axial and Radial)

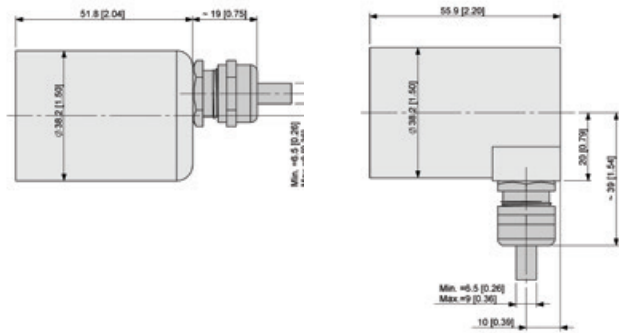

Mechanical Design for Ø 36 mm Housing

Stainless Steel Flanges

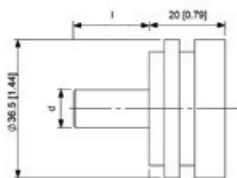

> Ø 36 mm Synchro

	d	l
5 D10	10	20

Mechanical Design for Ø 42 mm Housing

Stainless Steel Flanges

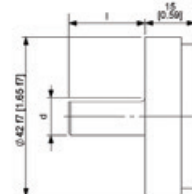

> Ø 42 mm Synchro

	d	l
5 G10	10	20

PRODUCT SELECTION GUIDE – IXARC ROTARY ENCODERS

Technical Drawings

> Ø 58 mm Housing

6 IP64, IP65, IP67 (Coated Steel)

7 Connection Type: Connector and Cable
(Axial and Radial)

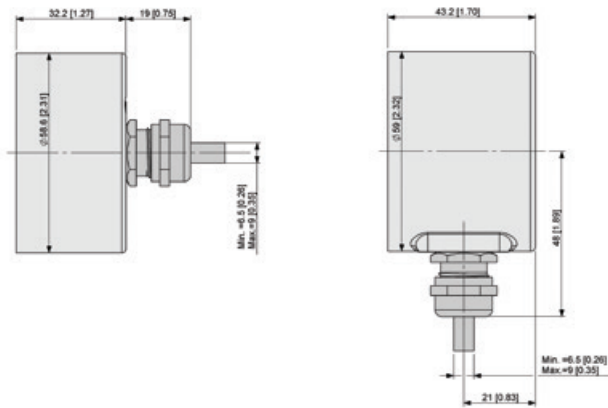

Mechanical Design for Ø 58 mm Housing

Aluminum Flanges

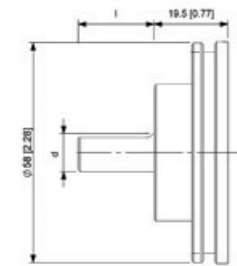

> 58 mm Clamp

	d	l
5 L06	6	10
5 L10	10	20
5 L12	12	20

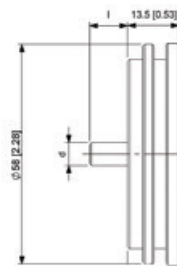

> Ø 58 mm Synchro

	d	l min/max
5 Y06	6	10
5 Y10	10	20
5 Y12	12	20

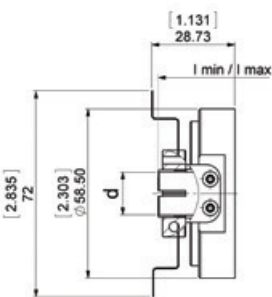

> Ø 58 mm Blind Hollow

	d	l
5 H06	6	15/30
5 H08	8	15/30
5 H10	10	15/30
5 H12	12	15/30
5 H14	14	15/30
5 H15	15	15/30

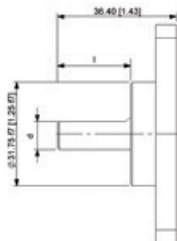

> Ø 2.5" Square

	d	l
5 4A7	9.52	20

PRODUCT SELECTION GUIDE – IXARC ROTARY ENCODERS

IXARC Optical Encoders



1 Certificate

D	CE/UL
E	Zone 1 & 21 (Oil+Gas)
M	Zone 1 & 21 (Mining)
S	SIL
F	Zone 2 & 22

2 Communication Interface

PPA1B	Parallel Binary
PPA1G	Parallel Gray
P1A1B	Parallel Preset Binary
P1A1G	Parallel Preset Gray
S101B	SSI Binary
S101G	SSI Gray
S401B	SSI Binary w. Pushbuttons
S401G	SSI Gray w. Pushbuttons
S5xxB	SSI+Incremental Binary + A/B/Z (RS-422)
S6xxB	SSI+Incremental Binary + A/B/Z (Push-Pull)
S5xxG	SSI+Incremental Gray + A/B/Z (RS-422)
S6xxG	SSI+Incremental Gray + A/B/Z (Push-Pull)
DPC1B	PROFIBUS DP
CAA1B	CANopen
CL00B	CANopen Lift
D2B1B	DeviceNet
IBA1B	Interbus
EIB1B	PROFINET IO
EEA1B	EtherNet/IP
E2A2B	POWERLINK
EC00B	EtherCAT
EM00B	Modbus/TCP

➤ For More Information



Please refer to our website for the full range of our products.

www.posital.com/en/absoluteoptical

3 Revolution

00	Singleturn
04	Multiturn: 4 bit (16 rev)
07	Multiturn: 7 bit (128 rev)
08	Multiturn: 8 bit (256 rev)
12	Multiturn: 12 bit (4096 rev)
14	Multiturn: 14 bit (16384 rev)

4 Resolution

08	8 bit (1024 Steps / 0.35°)
09	9 bit (360 Steps / 1°)
AA	9 bit (512 Steps / 0.7°)
10	10 bit (1024 Steps / 0.35°)
12	12 bit (4096 Steps / 0.088°)
13	13 bit (8192 Steps / 0.044°)
16	16 bit (65536 Steps / 0.005°)

5 Mechanical Design

Please see technical drawings on page 27 – 28

6 Protection Class

0	IP54 to IP65
S	IP54 to IP67 (with Shaft Sealing)

7 Connection Type

CAW	Cable: Axial 1 m
2AW	Cable: Axial 2 m
5AW	Cable: Axial 5 m
AAW	Cable: Axial 10 m
CRW	Cable: Radial 1 m
2RW	Cable: Radial 2 m
5RW	Cable: Radial 5 m
ARW	Cable: Radial 10 m
PAM	Connector: Axial M12, 5 pin (CANopen, Analog)
PAQ	Connector: Axial M12, 8 pin (SSI)
PAL	Connector: Axial M23, 12 pin (SSI)
PAP	Connector: Axial M23, 16 pin (Parallel, SSI)
PAT	Connector: Axial M27, 26 pin (Parallel)
PRM	Connector: Radial M12, 5 pin (CANopen, Analog)
PRQ	Connector: Radial M12, 8 pin (SSI)
PRL	Connector: Radial M23, 12 pin (SSI)
PRP	Connector: Radial M23, 16 pin (Parallel, SSI)
PRT	Connector: Radial M27, 26 pin (Parallel)
PRM	Connector: Radial 2 x M12 (Modbus)
PRM	Connector: Radial 3 x M12 (EtherNet/IP, PROFINET, POWERLINK, EtherCAT)
PRI	Connector: Radial 2 x M23, 9 pin (Interbus)
H3P	Connection Cap: 3 Cable Glands
H2M	Connection Cap: 2 x M20 Cable Glands (PROFIBUS, CANopen, DeviceNet)
H72	Connection Cap: 3 x M12 Connectors (PROFIBUS, CANopen, DeviceNet)
H2B	Connection Cap: 2 x M12 Connectors (CANopen, DeviceNet)
H1B	Connection Cap: 1 x M12 Connector (CANopen, DeviceNet)
H1C	Connection Cap: 1 x M23 Connector (DeviceNet)
HCC	Connection Cap: Without
HFZ	Connection Cap: 2 x Radial Blind Plug (OCE / OCM)
HFE	Connection Cap: 3 x Radial Blind Plug (OCE / OCM)
HFG	Connection Cap: Axial Blind Plug (OCE / OCM)
H1E	Connection Cap: 1 x Cable Gland (OCF)
H2E	Connection Cap: 2 x Cable Glands (OCF)
H3E	Connection Cap: 3 x Cable Glands (OCF)

PRODUCT SELECTION GUIDE – IXARC ROTARY ENCODERS

Technical Drawings

> Ø 58 mm Housing

6 IP64, IP65, IP67 (Coated Steel)

7 Connection Type: Connection Cap
(Fieldbus and Ethernet)

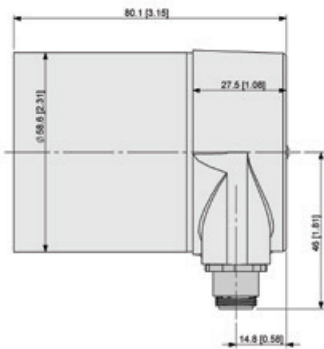

6 IP64, IP65, IP67 (Coated Steel)

7 Connection Type: Connector and Cable
(Axial and Radial)

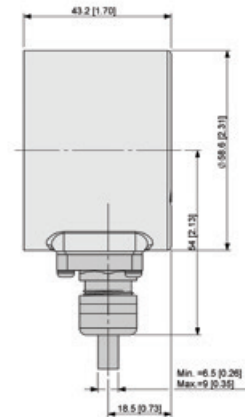
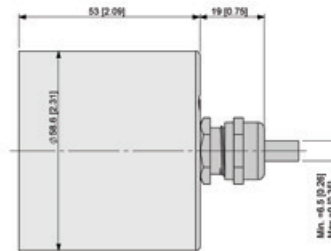

Mechanical Design for Ø 58 mm Housing

Aluminum Flanges

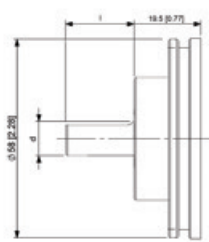

> 58 mm Clamp

	d	l
5 C06	6	10
5 C10	10	20
5 C12	12	20
5 CA7	9.5	20

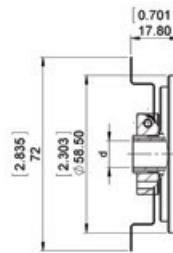

> Ø 58 mm Through

Hollow		
	d	l
5 T08	8	17.8
5 T10	10	17.8
5 T12	12	17.8

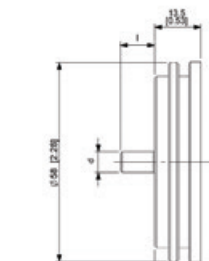

> Ø 58 mm Synchro

	d	l
5 S06	6	10
5 S10	10	20
5 S12	12	20

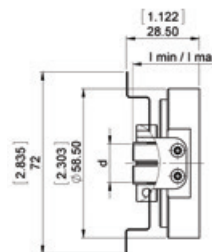

> Ø 58 mm Blind Hollow

	d	l min/max
5 B06	6	15/30
5 B08	8	15/30
5 B10	10	15/30
5 B11	11	15/30
5 B12	12	15/30
5 B14	14	15/30
5 B15	15	15/30

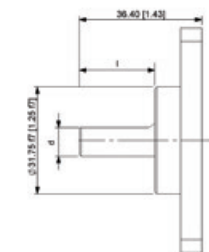

> Ø 2.5" Square

	d	l
5 9A7	9.52	20

PRODUCT SELECTION GUIDE – IXARC ROTARY ENCODERS

Technical Drawings

> Ø 78 mm Housing

6 IP64, IP65, IP67 (Explosion Proof)

7 Connection Type: Connection Cap

(3 Radial Exits, 2 Axial Exits, 2 Radial Exits)

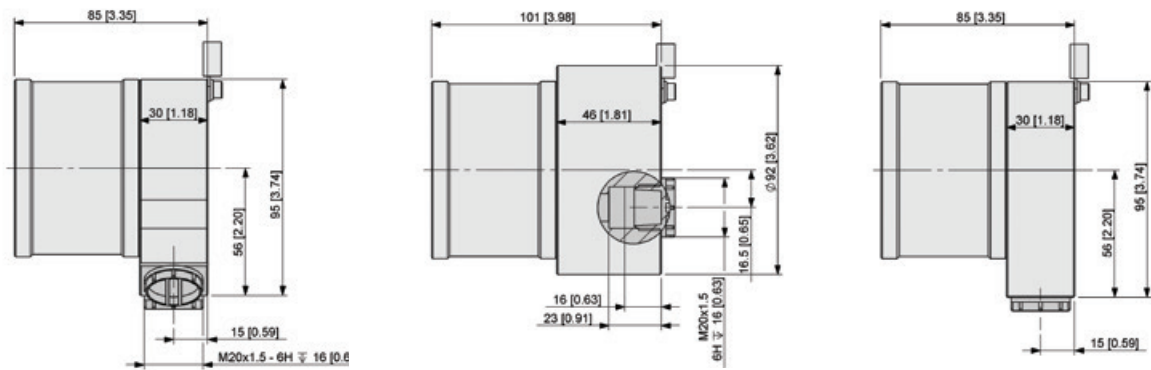

Mechanical Design for Ø 78 mm Housing

Aluminum / Steel Flanges

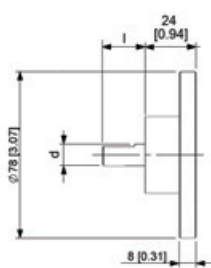

> Ø 78 mm Clamp

	d	l
7 F10	10	20
7 F12	12	20

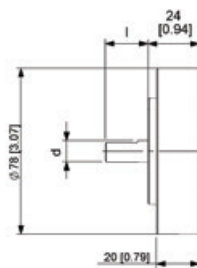

> Ø 78 mm Synchro

	d	l
7 W10	10	20
7 W12	12	20

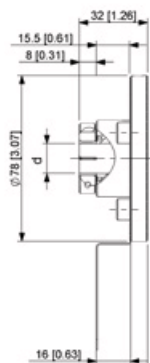

> Ø 78 mm Blind Hollow

	d	l
7 E14	14	23.5

LINARIX LINEAR SENSORS



Robust Draw Wire Displacement Measurement

TECHNOLOGY – LINARIX LINEAR SENSORS

Repeatable Length Measurement

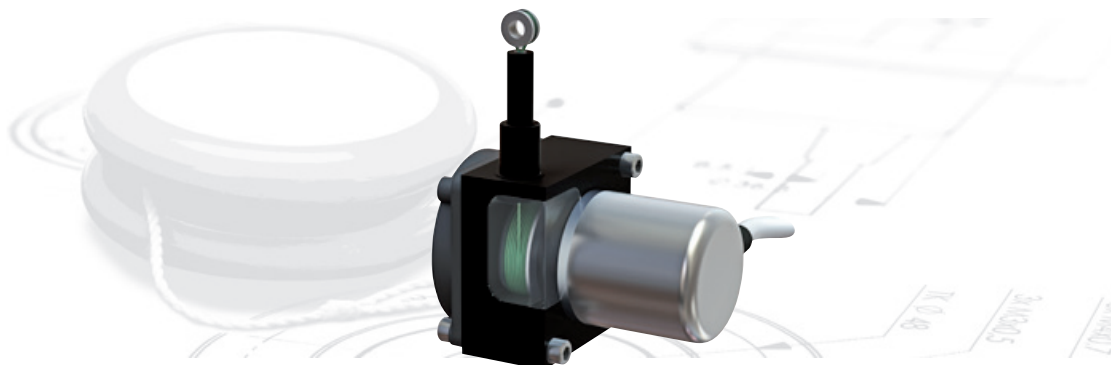

POSITAL's LINARIX draw wire sensors measure linear motion by displacing a retractable stainless steel wire **A** wound around a cable drum **B** that actuates the rotary encoder **C** coupled to it. The encoder then provides a proportional output. Measurements are highly accurate, reliable and the systems have very long lifetimes.

The LINARIX line offers a wide range of measurement lengths ranging from 1 m to 10 m (3 ft to 33 ft) and also provides position output in almost every available industrial interfaces both analog and digital.





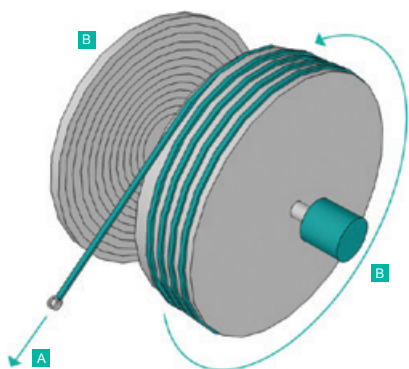

Compared to conventional linear pots and linear measurement systems using multiple gears and encoders, the LINARIX line of sensors are more durable and can be used to replace them directly, avoiding the common problems of slippage and wear. Draw wire sensors from POSITAL provide extremely precise measurements because of the inherent accuracy of the encoders, while the rugged construction ensures reliable performance, even under extreme conditions.

The POSITAL products listed below are classified according to measurement range and level of robustness. This gives the customer the opportunity to select the right configuration for their application.



PRODUCT OVERVIEW – LINARIX LINEAR SENSORS

Linear Sensors up to 3 m [10 ft]

		Measuring Range in m [in]	Accuracy in [±%FSO]	Wire Diameter in mm [in]	Wire Material	Max. Extension Force in N	Min. Retraction Force in N	Linear Resolution in $\mu\text{m}^{(1)}$	Drum Circumference in mm [in]	Optical Encoder	Magnetic Encoder
	<ul style="list-style-type: none"> ➤ Machined Metal ➤ Rectangular ➤ Enclosure: A 	1.25 [49]	0.04	Ø0.48 [0.018]	Nylon Coated Stainless Steel	2.34	1.26	24	Ø100 [3.9]		■
	<ul style="list-style-type: none"> ➤ Plastic ➤ Compact Design ➤ Enclosure: N 	1.25 [49]	0.05	Ø0.36 [0.014]	Coated Polyamide Stainless Steel	1.50	1.00	31	Ø125 [4.9]		■
	<ul style="list-style-type: none"> ➤ Machined Metal ➤ Cylindrical ➤ Enclosure: P 	1.74 [69]	0.02	Ø0.45 [0.017]	Coated Polyamide Stainless Steel	5.00	3.50	36	Ø149 [5.9]	■	■
	<ul style="list-style-type: none"> ➤ Machined Metal ➤ Rectangular ➤ Enclosure: C 	2.00 [79]	0.02	Ø0.45 [0.017]	Plastic Coated Stainless Steel	2.00	1.20	24	Ø100 [3.9]		■
	<ul style="list-style-type: none"> ➤ Plastic ➤ Compact Design ➤ Enclosure: M 	2.10 [83]	0.05	Ø0.45 [0.017]	Coated Polyamide Stainless Steel	5.00	3.50	52	Ø215 [8.5]		■
	<ul style="list-style-type: none"> ➤ Machined Metal ➤ Rectangular ➤ Enclosure: B 	3.00 [118]	0.04	Ø0.45 [0.017]	Nylon Coated Stainless Steel	3.90	2.10	49	Ø200 [7.9]		■
	<ul style="list-style-type: none"> ➤ Machined Metal ➤ Rectangular ➤ Enclosure: D 	3.00 [118]	0.01	Ø0.87 [0.034]	Plastic Coated Stainless Steel	3.00	2.50	49	Ø200 [7.9]	■	■

1) Linear Resolution based on an encoder with 12 bit resolution, Operating Temperature: -20 to +80 °C [-4 to +176 °F]

LINARIX linear sensors are available with the following interfaces:



➤ For More Information



Please refer to our website for the full range of our products.







www.posital.com/en/linearsensors

➤ Related Industries



PRODUCT OVERVIEW – LINARIX LINEAR SENSORS

Linear Sensors up to 10 m [33 ft]

		Measuring Range in m [in]	Accuracy in [±%FSO]	Wire Diameter in mm [in]	Wire Material	Max. Extension Force in N	Min. Retraction Force in N	Linear Resolution in $\mu\text{m}^{(1)}$	Drum Circumference in mm [in]	Optical Encoder	Magnetic Encoder
	<ul style="list-style-type: none"> > Extruded Metal > Compact Design > Enclosure: F 	3.00 [118]	0.02	Ø0.80 [0.031]	Coated Polyamide Stainless Steel	9.0	5.5	63	Ø260 [10.2]	■	■
	<ul style="list-style-type: none"> > Extruded Metal > Practical Mounting > Enclosure: G 	5.00 [197]	0.02	Ø1.00 [0.039]	Nylon Coated Stainless Steel	16.0	4.0	77	Ø315 [12.4]	■	■
	<ul style="list-style-type: none"> > Die Cast Metal > Rugged Housing > Enclosure: K 	5.08 [200]	0.02	Ø0.86 [0.033]	Nylon Coated Stainless Steel	6.5	3.5	78	Ø320 [12.6]	■	■
	<ul style="list-style-type: none"> > Machined Metal > Rectangular > Enclosure: E 	6.00 [236]	0.01	Ø0.54 [0.021]	Stainless Steel	8.00	3.0	40	Ø200 [7.9]	■	■
	<ul style="list-style-type: none"> > Extruded Metal > Long Lifetime > Enclosure: H 	10.00 [394]	0.01	Ø1.00 [0.039]	Nylon Coated Stainless Steel	21.0	8.0	77	Ø315 [12.4]	■	■
	<ul style="list-style-type: none"> > Die Cast Metal > Rugged Housing > Enclosure: L 	10.16 [400]	0.02	Ø0.86 [0.033]	Nylon Coated Stainless Steel	6.5	3.5	78	Ø320 [12.6]	■	■

1) Linear Resolution based on an encoder with 12 bit resolution, Operating Temperature: -20 to +80 °C [-4 to +176 °F]

LINARIX linear sensors are available with the following interfaces:



> For More Information



Please refer to our website for the full range of our products.

www.posital.com/en/linearsensors

> Related Industries



PRODUCT SELECTION GUIDE – LINARIX LINEAR SENSORS

LINARIX Linear Sensors

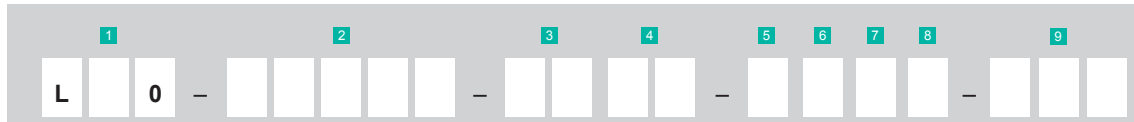

1 Technology

- D** Optical
- M** Magnetic $\leq 0.36^\circ$
- U** Magnetic $\leq 0.09^\circ$ (only available with SSI Interface)

2 Communication Interface

- AV001** Voltage: 0 to 5 V
- AVP01** Voltage: 0 to 5 V w. Pushbuttons
- AV002** Voltage: 0 to 10 V
- AVP02** Voltage: 0 to 10 V w. Pushbuttons
- AC005** Current: 4 to 20 mA
- ACP05** Current: 4 to 20 mA w. Pushbuttons
- P100B** Parallel Binary with Preset
- P100G** Parallel Gray with Preset
- S101B** SSI Binary
- S101G** SSI Gray
- S5xxB** SSI Binary + Incremental A/B/Z (RS-422)
- S6xxB** SSI Binary + Incremental A/B/Z (Push-Pull)
- S5xxG** SSI Gray + Incremental A/B/Z (RS-422)
- S6xxG** SSI Gray + Incremental A/B/Z (Push-Pull)
- INxx** Incremental
- DPC1B** PROFIBUS DP
- CAA1B** CANopen
- CL00B** CANopen Lift
- D2B1B** DeviceNet
- IBA1B** Interbus
- EIB1B** PROFINET IO
- EEA0B** EtherNet/IP
- E2A1B** POWERLINK
- EM00B** Modbus/TCP

3 Encoder Revolution

- 04** Multiturn: 4 bit (16 rev)
- 12** Multiturn: 12 bit (4096 rev)

> For More Information



Please refer to our website for the full range of our products.

www.posital.com/en/linearsensors

4 Encoder Resolution

- 12** 12 bit
- 13** 13 bit
- 14** 14 bit
- 16** 16 bit

5 Measurement Range

- 1** 1 m
- 2** 2 m
- 3** 3 m
- 5** 5 m
- 6** 6 m
- A** 10 m

6 Draw Wire Enclosure and

7 Encoder Connection Orientation

Please see technical drawings on page 34 – 36

8 Protection Class Encoder

- A** IP54
- 0** IP54 to IP65

9 Connection Type

- 000** Draw Wire Only
- CRW** Cable: Radial 1 m
- ARW** Cable: Radial 10 m
- CAW** Cable: Axial 1 m
- AAW** Cable: Axial 10 m
- PRL** Connector: Radial, M23 12 pin,
- PRP** Connector: Radial, M23 16 pin
- PRT** Connector: Radial, M26 26 pin
- PRM** Connector: Radial, M12 5 pin
- PRN** Connector: Radial, 2 x M12 5 pin
- PRQ** Connector: Radial, M12 8 pin
- PAL** Connector: Axial, M23 12 pin
- PAP** Connector: Axial, M23 16 pin
- PAM** Connector: Axial, M12 5 pin
- PAQ** Connector: Axial, M12 8 pin
- H3P** Cable Glands: M12 x 3
- H1B** Connector: M12 x 1
- H2B** Connector: M12 x 2
- H1C** Connector: M23 x 1

PRODUCT SELECTION GUIDE – LINARIX LINEAR SENSORS

Technical Drawings

L - - - - - 6 7 - - - - -

6 Draw Wire Enclosure L and K

7 Encoder Connection Orientation

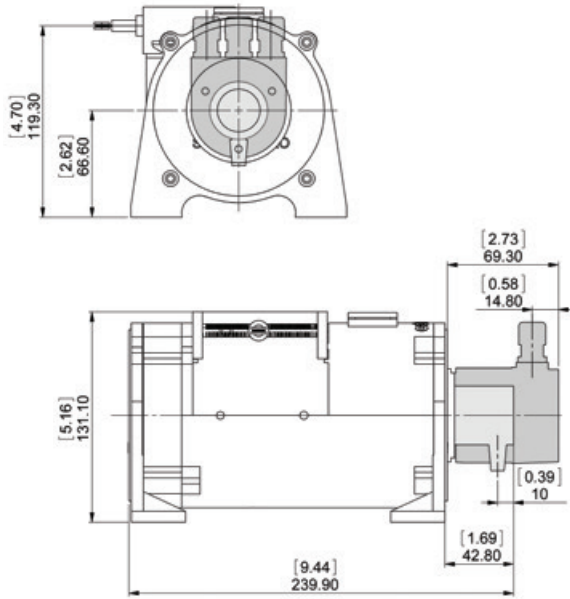

6 Draw Wire Enclosure G

7 Encoder Connection Orientation

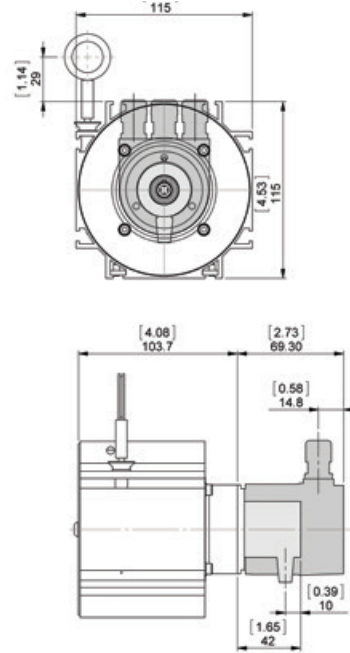

6 Draw Wire Enclosure F

7 Encoder Connection Orientation

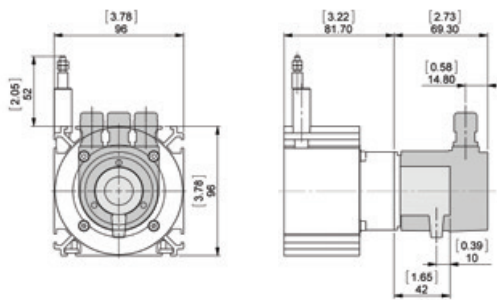

6 Draw Wire Enclosure H

7 Encoder Connection Orientation

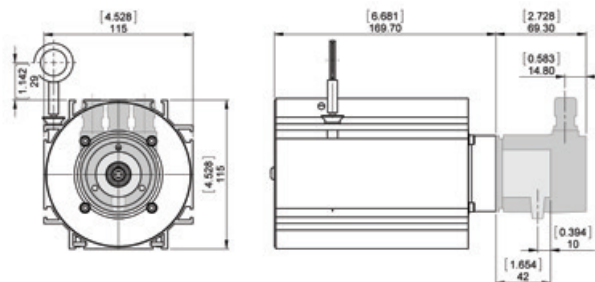

PRODUCT SELECTION GUIDE – LINARIX LINEAR SENSORS

Technical Drawings

L - - - - - **6 7** - - - - -

6 Draw Wire Enclosure E

7 Encoder Connection Orientation

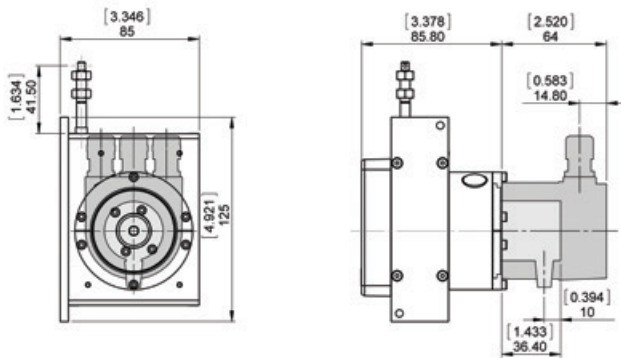

6 Draw Wire Enclosure B

7 Encoder Connection Orientation

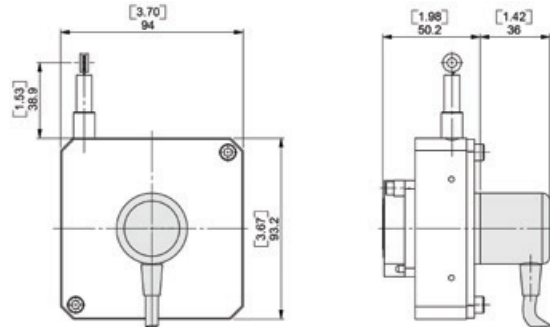

6 Draw Wire Enclosure D

7 Encoder Connection Orientation

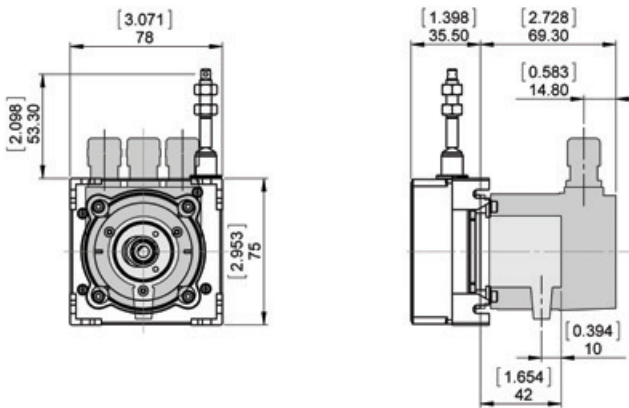

6 Draw Wire Enclosure A

7 Encoder Connection Orientation

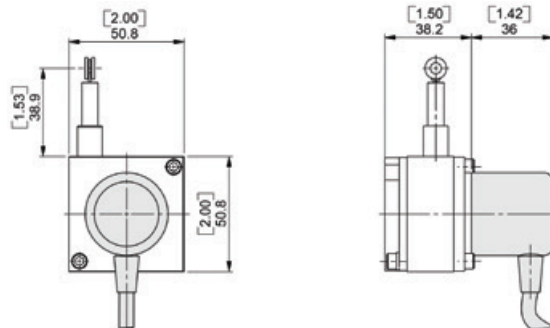

PRODUCT SELECTION GUIDE – LINARIX LINEAR SENSORS

Technical Drawings

L - - - - - 6 7 - - - - -

6 Draw Wire Enclosure P

6 Draw Wire Enclosure C

7 Encoder Connection Orientation

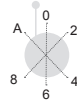

7 Encoder Connection Orientation

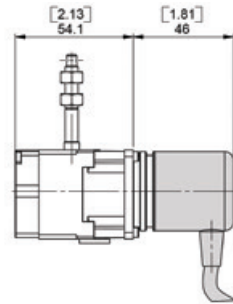
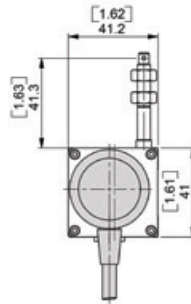
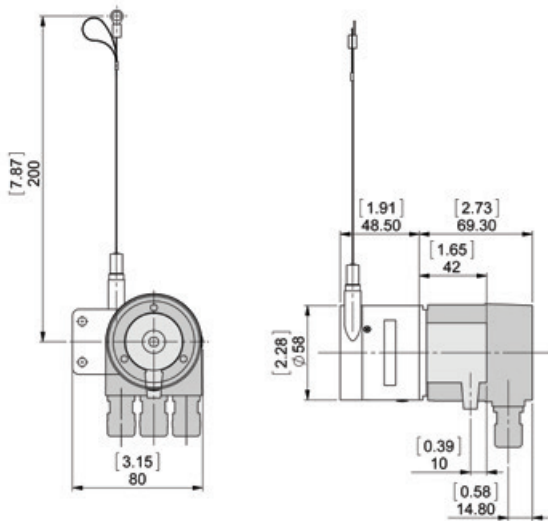

6 Draw Wire Enclosure N

6 Draw Wire Enclosure M

7 Encoder Connection Orientation



7 Encoder Connection Orientation

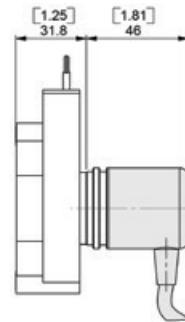
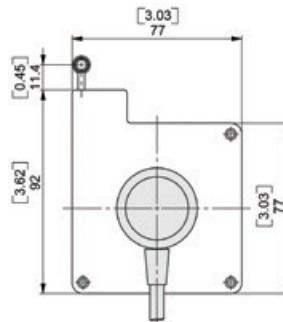
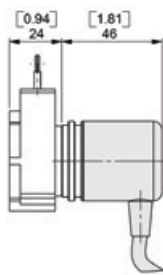
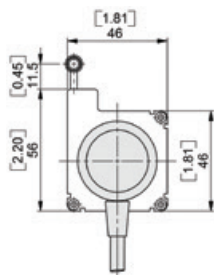

TILTIX INCLINOMETER



Precise Tilt Measurement

TECHNOLOGY – TILTIX INCLINOMETERS

Highly Dynamic MEMS and High Precision Fluid Cell Technology



POSITAL's TILTIX Inclinometers are based on highly dynamic MEMS (Micro-Electro-Mechanical Systems) technology or on high precision fluid cell technology.

MEMS

In MEMS devices, a 'micro mass' **A** is suspended in a flexible support structure **B**. Any movement will induce a displacement of the mass, resulting in a change of capacitance between the mass and the supporting structure. Changes of inclination (tilt) are calculated from the changes in measured capacitance. These inclinometers have a measurement range of $\pm 80^\circ$ in two axes or 360° in one axis. The devices can withstand shock and vibration loadings of up to 100 g, as per EN 60068-2-27.





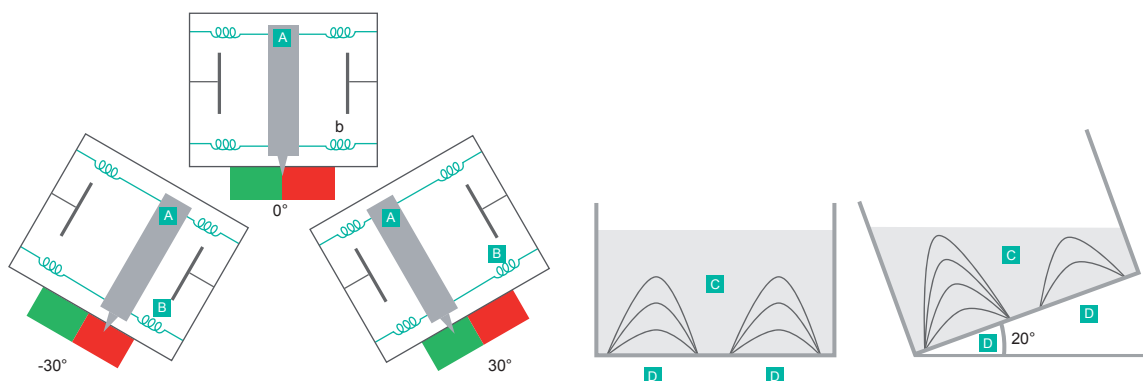

Fluid Cell

In fluid filled inclinometers, the sensor cell is partially filled with an electrolytic liquid **C** while the walls are covered with a pair of electrodes **D**. As the sensor tilts, the level of fluid covering the electrodes changes. This results in an increase or decrease in the conductivity between the electrodes. The degree of tilt can be calculated from this measurement. Fluid cell inclinometers are capable of measuring inclinations of up to $\pm 30^\circ$ with a very high levels of precision. The natural damping of the liquids makes these inclinometers stable as well as precise.



PRODUCT OVERVIEW – TILTIX INCLINOMETERS

MEMS Technology

CE		Max. Protection Class	Communication Interface	Resolution		Accuracy	Die Cast Aluminum Fibre-Reinforced Plastic	Supply Voltage in V	Cable	Connector	Shock / Vibration ¹⁾ in g
				1 Axis 0 to 360°	2 Axis ±80°						
	➤ MEMS	IP69K	Analog	■	■	0.01°	0.1°	■	■	■	100
	➤ Programmable Analog	IP68	Voltage								20
	➤ Rugged Housing			Current							
	➤ MEMS	IP69K	SSI	■		0.04°	0.1°	■	■	■	100
	➤ Serial	IP68	RS232								20
	➤ Rugged Housing										
	➤ MEMS	IP69K	CANopen	■	■	0.01°	0.1°	■	■	■	100
	➤ Bus Interface	IP68	DeviceNet								20
	➤ Rugged Housing		SAE J1939								
	➤ MEMS	IP69K	Analog	■	■	0.01°	0.1°	■	■	■	100
	➤ Programmable Analog	IP68	Voltage								20
	➤ Compact Design		Current								
	➤ MEMS	IP67	SSI	■		0.04°	0.1°	■	■	■	100
	➤ Serial		RS232								20
	➤ Compact Design										
	➤ MEMS	IP69K	CANopen	■	■	0.01°	0.1°	■	■	■	100
	➤ Bus Interface	IP68	DeviceNet								20
	➤ Compact Design		ModbusRTU								
	➤ MEMS	IP69K	Analog	■	■	0.01°	0.5°	■	■	■	100
	➤ Cost Efficient	IP68	Voltage								20
	➤ Compact Design		Current								

1) Shock and Vibration Based on (EN 60068-2-27) / (EN 60068-2-6), Operating Temperature: -40 to +85 °C [-40 to +185 °F]

TILTIX inclinometers based on MEMS technology are available with the following interfaces:

ANALOG

CANopen

SSI

DeviceNet

RS232

Modbus

SAE J1939

➤ For More Information



Please refer to our website for the full range of our products.







www.posital.com/en/mems

➤ Related Industries



PRODUCT OVERVIEW – TILTIX INCLINIMETERS

Fluid Cell Technology

CE		Max. Protection Class	Communication Interface	2 Axis ±5 to 40°	Resolution	Accuracy	Aluminum	Fibre-Reinforced Plastic	Supply Voltage in V	Cable	Connector	Shock / Vibration ¹⁾ in g
	<ul style="list-style-type: none"> > Fluid Cell > Analog Voltage > IP67 	IP67	Analog Voltage	■	0.001°	0.01°	■		10-30	■	■	30 5
	<ul style="list-style-type: none"> > Fluid Cell > Analog Current > IP67 	IP67	Analog Current	■	0.001°	0.01°	■		10-30	■	■	30 5
	<ul style="list-style-type: none"> > Fluid Cell > Analog PWM > IP67 	IP67	Analog PWM	■	0.001°	0.01°	■		10-30	■	■	30 5
	<ul style="list-style-type: none"> > Fluid Cell > Analog Switch > IP67 	IP67	Analog Switch	■	0.001°	0.01°	■		10-30	■	■	30 5
	<ul style="list-style-type: none"> > Fluid Cell > RS232 > IP67 	IP67	RS232	■	0.001°	0.01°	■		10-30	■	■	30 5
	<ul style="list-style-type: none"> > Fluid Cell > Bus Interfaces > IP67 	IP67	CANopen	■	0.001°	0.01°	■		10-30	■	■	30 5

1) Shock and Vibration Based on (EN 60068-2-27) / (EN 60068-2-6), Operating Temperature: -40 to +85 °C [-40 to +185 °F]

TILTIX inclinometers based on Fluid Cell technology are available with the following interfaces

ANALOG

CANopen

RS232

PWM

SWITCH

> For More Information



Please refer to our website for the full range of our products.

www.posital.com/en/fluidcell

> Related Industries



PRODUCT SELECTION GUIDE – TILTIX INCLINOMETERS

TILTIX Inclinometer



1 Technology

ACS MEMS, Accuracy 0.1°

ADS MEMS, Accuracy 0.5°

AGS Fluid Cell

2 Measurement Range

010 ±10° (ACS, ADS)

020 ±20° (ACS, ADS)

040 ±40° (ACS, ADS)

060 ±60° (ACS, ADS)

080 ±80° (ACS, ADS)

090 90° (ACS, ADS)

120 120° (ACS, ADS)

180 180° (ACS, ADS)

270 270° (ACS, ADS)

360 360° (ACS, ADS)

005 ±5° (AGS)

015 ±15° (AGS)

030 ±30° (AGS)

3 Number of Axis

1 Single Axis (ACS, ADS)

2 Dual Axis

4 Communication Interface

CA01 CANopen (ACS)

M100 Modbus RTU (ACS)

D101 DeviceNet (ACS)

S101 SSI Binary (ACS)

S302 SSI Gray (ACS)

C901 J1939 (ACS)

SV00 Voltage 0.5 to 4.5 V + RS232 (ACS, ADS)

SV10 Voltage 0 to 5 V + RS232 (ACS, ADS)

SV20 Voltage 0 to 10 V + RS232 (ACS, ADS)

SV40 Voltage 0.5 to 9.5 V + RS232 (ACS, ADS)

SC00 Current 4 to 20 mA + RS232 (ACS, ADS)

SC1 Current 4 to 20 mA + RS232 (AGS)

SV1 Voltage 0.5 to 4.5 V + RS232 (AGS)

CA1 CANopen (AGS)

S01 RS232 (AGS)

SP1 PWM (AGS)

SS1 Switch (AGS)

5 Mounting

H Horizontal (Dual Axis)

V Vertical (Single Axis)

6 Housing Material

E2 Fibre-Reinforced Plastic (ACS, ADS)

H2 Aluminum (ACS, ADS)

0H Aluminum (AGS)

7 Connection Type

PM Connector: M12 (ACS, ADS)

CW Cable Exit: 1m (ACS, ADS)

2W Cable Exit: 2 m (ACS, ADS)

5W Cable Exit: 5 m (ACS, ADS)

AW Cable Exit: 10 m (ACS, ADS)

PL Connector: 2 x M12 Male (ACS)

PN Connector: 1 x M12 Male & 1 x M12 Female (ACS)

P8M Connector: M12 (AGS)

CRW Cable Exit: 1 m (AGS)

► For More Information



Please refer to our website for the full range of our products.

www.posital.com/en/inclinometer

PRODUCT SELECTION GUIDE - TILTIX INCLINOMETERS

Technical Drawings

1 A_S - - - - - 6 - 7

1 MEMS

1 Technology MEMS

6 Housing Material: Aluminum H2

7 Connection Type: Connector PN

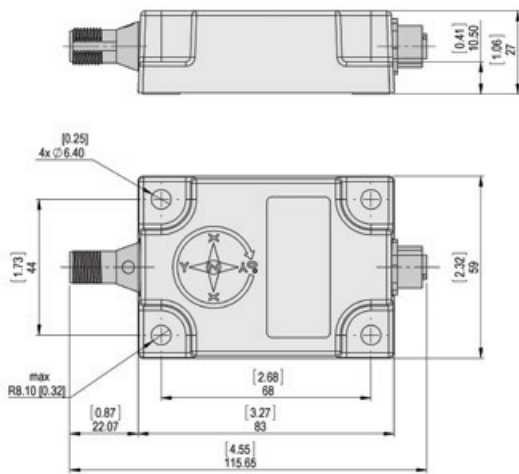

1 MEMS

1 Technology MEMS

6 Housing Material: Aluminum H2

7 Connection Type: Connector PL

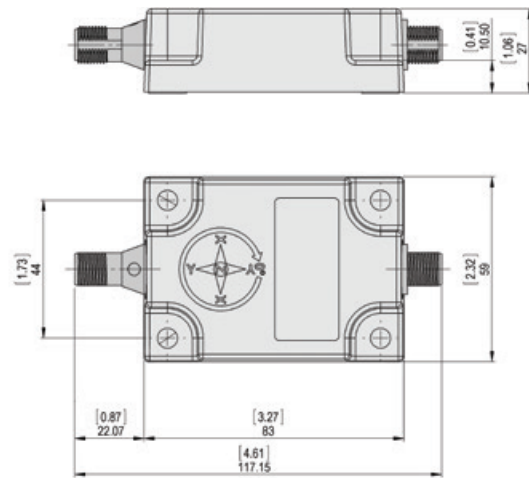

1 MEMS

1 Technology MEMS

6 Housing Material: Aluminum H2

7 Connection Type: Connector PM

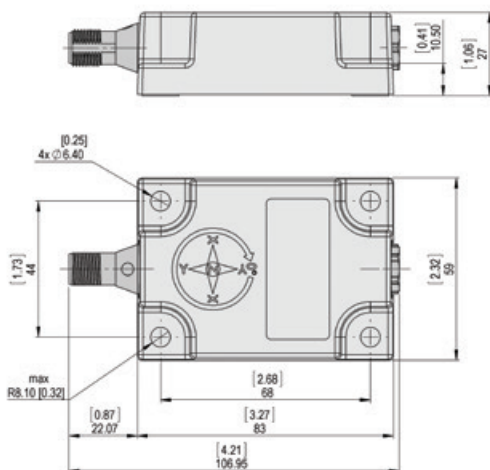

1 MEMS

1 Technology MEMS

6 Housing Material: Aluminum H2

7 Connection Type: Cable

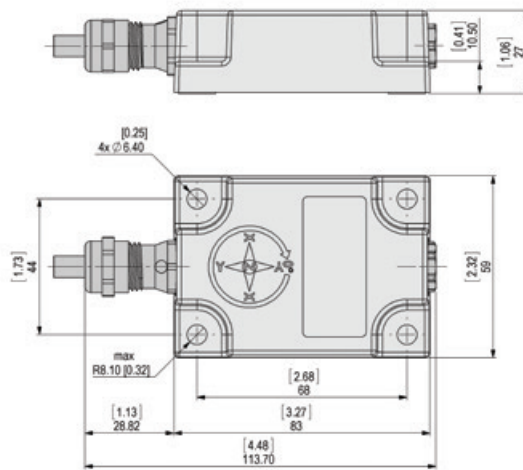

PRODUCT SELECTION GUIDE - TILTIX INCLINOMETERS

Technical Drawings

1 A_S - - - - - 6 - 7

1 MEMS

- 1 Technology MEMS
- 6 Housing Material: Fibre-Reinforced Plastic E2
- 7 Connection Type: Connector PM

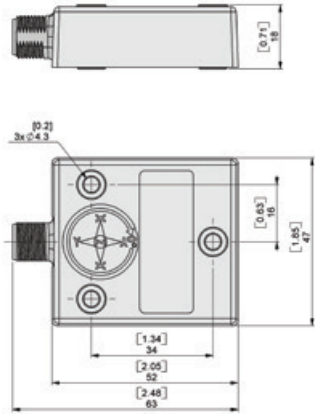

1 MEMS

- 1 Technology MEMS
- 6 Housing Material: Fibre-Reinforced Plastic E2
- 7 Connection Type: Cable

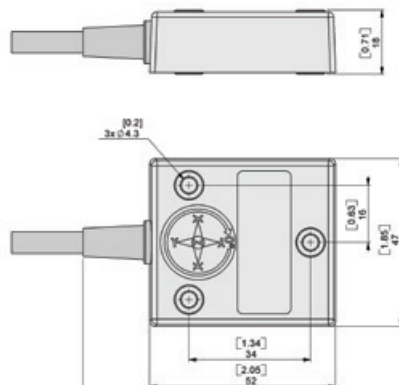

1 Fluid Cell

- 1 Technology: Fluid Cell
- 6 Housing Material: Aluminum 0H
- 7 Connection Type: Connector P8M

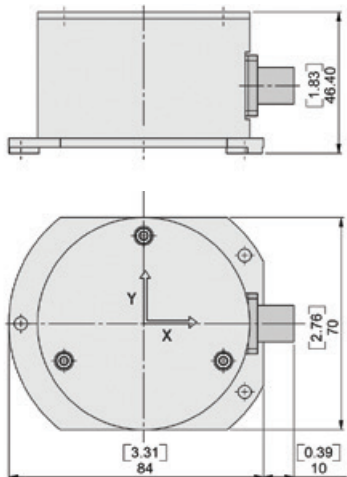





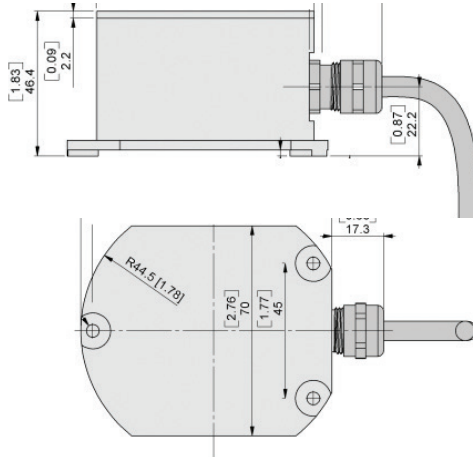



1 Fluid Cell

- 1 Technology: Fluid Cell
- 6 Housing Material: Aluminum 0H
- 7 Connection Type: Cable CRW



PRODUCT OVERVIEW – ACCESSORIES

Mounting Fixtures

		Flange / Shaft Ø Dimensions in mm	Material	Compatible with Mechanical Design
	<ul style="list-style-type: none"> > Reducing Adapter > Used in Hub Shaft > Used in Throw Hollow Shaft 	15 to (6–14) 12 to (8–11)	Stainless Steel Brass	T, B, V Flanges
	<ul style="list-style-type: none"> > Coupling > Bellow Type > Flexible Design 	6 to 6, 6 to 8 6 to 10, 8 to 10, 10 to 10	Flange: Aluminum Membrane: Polyamide	All IXARC Solid Shafts
	<ul style="list-style-type: none"> > Coupling > Disc Type > High Speed Application 	6 to 6, 6 to 10 10 to 10, 10 to 12	Flange: Aluminum Membrane: Polyamide	All IXARC Solid Shafts
	<ul style="list-style-type: none"> > Coupling > Jaw Type > 3 Part Coupling 	6 to 6, 6 to 8 6 to 10, 8 to 10 10 to 10, 10 to 12	Hub: Aluminum Spider: PUR	All IXARC Solid Shafts
	<ul style="list-style-type: none"> > Flange Adapter > Used in Clamp Flange > Used in Synchro Flange 	58 to (63.5, 78, 80, 90, 100)	Aluminum	All IXARC Clamp and Synchro Flanges 58 mm
	<ul style="list-style-type: none"> > Mounting Bracket > MGY 58, MOWI 123 > Used in Solid Shaft 	58	Glass-fiber reinforced	All IXARC Clamp and Synchro Flanges 58 mm
	<ul style="list-style-type: none"> > Torque Support > Includes Tethers > Includes Clamping Ring 	36 58	Aluminum Stainless Steel	B150, B120, T120, V060, V120, A060
	<ul style="list-style-type: none"> > Clamp Discs > Mount Encoder onto Surface > Clamp Flange 	36 58	Aluminum	All IXARC Clamp Flanges

> For More Information







Please refer to our website for the full range of our products.

www.posital.com/en/accessories

PRODUCT OVERVIEW – ACCESSORIES

Connectors and Cables

		Length in m	Pins / Number of Cables	Cable Material	Connector Material	Protection Class	Compatible with Connection Type
	> Connector		4 pin D		Metal	IP67	IXARC: PRM, PAM, PRQ, PAQ TILTIX: PM
	> M12		5 pin A				
	> Male and Female		8 pin A				
	> Connector		9		Metal	IP67	IXARC: PRL, PAL, PRP, PAP, PRI
	> M23		12				
	> Female		16				
	> Connector		26		Metal	IP67	IXARC: PAT, PRT
	> M27						
	> Female						
	> Cable	2	4 pin D	PUR	PBT	IP69K	IXARC: PRM, PAM, PRQ, PAQ TILTIX: PM
	> M12 Connector	5	5 pin A	PVC	Metal		
	> Open Ends, RJ45	10	8 pin A				
	> Cable	2	9	PUR	Metal	IP67	IXARC: PRL, PAL, PRP, PAP, PAT, PRT, PRI
	> M23, M27 Connector	5	12	PVC			
	> Open Ends	10	16, 26				

Configuration and Interface Modules



SSI2USB Module

- > Easy interface of SSI device to USB port of PC
- > Graphical User Interface to view and store SSI Data
- > Power Supply to SSI device (max 12 Volts) using USB Port
- > Three independent tri-state outputs
- > Could be used as a Virtual Com port device



Voltage Panel Display

- > Measures voltage from 0 to 40 V DC
- > 2.4" color TFT screen
- > Use PanelPilot software, to setup and customize the display
- > Programmable via the USB interface
- > Simple panel mounting solution
- > Wide operating voltage of 4 V to 30 V DC

GLOSSARY

Technical Terms

> Analog	A common standard with either a voltage or a current output.
> ATEX / IECEx	ATEX and IECEx norms define essential requirements for equipment and protective systems intended for use in potentially explosive atmospheres.
> CANopen	CANopen is a Fieldbus protocol using CAN networks.
> CANopen Lift	CANopen Lift is a Fieldbus protocol for elevator applications.
> CE	With the CE marking POSITAL declares that the product conforms with essential requirements of the applicable EC directives.
> DeviceNet	DeviceNet is a Fieldbus system based on CAN networks and CIP protocol, managed by ODVA, widely used in factory automation and available on many PLCs.
> EtherNet/IP	EtherNet/IP is an industrial communication protocol developed by Rockwell Automation and managed by ODVA. It is based on CIP and TCP/IP.
> ETHERNET POWERLINK	ETHERNET POWERLINK is a real-time communication system based on EtherNet networks and managed by EPSG.
> Interbus	Interbus is a Fieldbus technology developed by Phoenix Contact.
> IP54	Protected against dust and splash water from any direction.
> IP65	Dust tight and protected against water jets from any direction.
> IP67	Dust tight and protected against temporary immersion up to 1 m.
> IP68	Dust tight and protected against long periods of immersion under pressure.
> IP69K	Dust tight and protected against high temperature (steam) and high pressure water jets from any direction.
> Modbus	Modbus is a serial protocol managed by the Modbus Organization.
> Parallel	All bits of the position output are transferred simultaneously using one line for each bit.
> PROFIBUS	PROFIBUS is available on many PLCs and one of the most common Fieldbus technologies in factory automation and other areas. It is based on RS485. There are different versions of PROFIBUS and different device profiles.
> PROFINET	PROFINET is an Industrial Ethernet standard from „PROFIBUS&PROFINET International“ designed for automation.
> SAE J1939	SAE J1939 is a Fieldbus standard used for communication by the car and heavy-duty truck industry.
> SIL	SIL (Safety Integrity Level) is defined as a relative level of risk-reduction provided by a safety function. In accordance with the requirements of IEC 61508/EN 62061, PL e and Cat.4 according to EN ISO 13849-1.
> SSI	SSI is a widely used serial interface with point-to-point connection between PLC/Master and encoder. It is based on the RS422 standard.
> UL	UL (Underwriters Laboratories) is a US based consulting and certification company providing safety standards for electrical devices. UL marking confirms the compliance with applicable UL safety standards.

POSITAL

FRABA

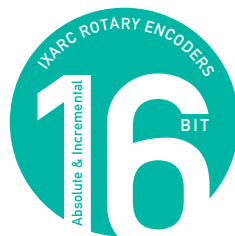

www.posital.com

AMERICA
FRABA Inc.
1800 East State Street, Suite 148 Hamilton,
NJ 08609-2020, USA
T +1 609 750-8705, F +1 609 750-8703
www.posital.com, info@posital.com

EUROPE
FRABA AG
Carlswerkstraße 13c
51063 Cologne, Germany
T +49 221 96213-0, F +49 221 96213-20
www.posital.com, info@posital.eu

ASIA
FRABA Pte. Ltd.
20 Kallang Ave #01-00
Pico Creative Centre, Singapore 339411
T +65 6514 8880, F +65 6271 1792
www.posital.com, info@posital.sg