

# POSIROT<sup>®</sup>

Magnetic Angle Sensors

**PRAS27**  
**Magnetic Angle Sensor**

Datasheet

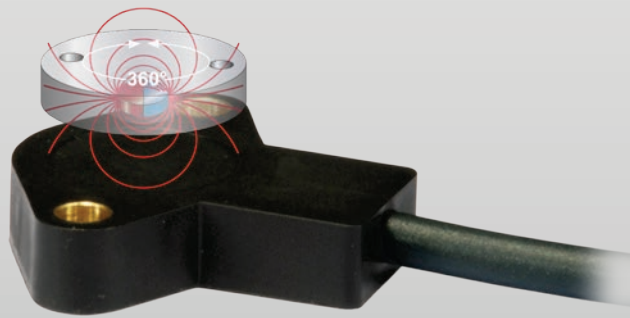

### **Copyright**

© ASM GmbH  
Am Bleichbach 18-24  
85452 Moosinning  
Germany

The information presented in this data sheet does not form part of any quotation or contract, is believed to be accurate and reliable and may be changed without notice. No liability will be accepted by ASM for any consequence of its use. Publication thereof does not convey nor imply any license under patent or industrial or intellectual property rights. Applications that are described herein for any of these products are for illustrative purpose only.

ASM makes no representation or warranty that such applications will be suitable for the specified use without further testing or modification.

<b>Analog output</b> .....	<b>4</b>
Specifications .....	4
Order code .....	5
<b>Analog output, redundant</b> .....	<b>6</b>
Specifications .....	6
Order code .....	7
<b>Dimensions</b> .....	<b>8</b>
<b>Position magnets</b> .....	<b>9</b>
<b>Output specification</b> .....	<b>13</b>
Analog output .....	13
Analog output, redundant.....	16
<b>Characteristics for magnetic angle sensors</b> .....	<b>18</b>
<b>Accessories</b> .....	<b>19</b>
PRAS27 Magnetic Shield.....	19
<b>Deutsch connector</b> .....	<b>20</b>

## Analog output

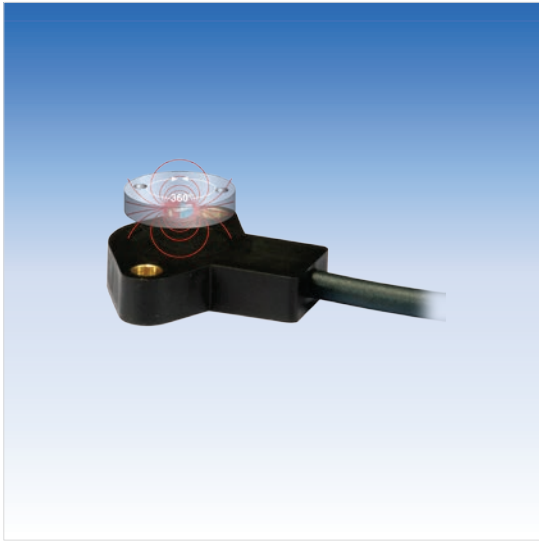

### Sensor features

- Measurement range 0 ... 360°
- Protection class IP67
- Analog output
- Compact, low profile housing
- Non-contact with external position magnet, no wear
- Housing: Plastic

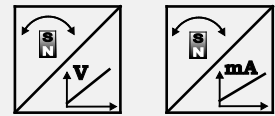

## Specifications

<b>Output</b>	Voltage 0.5 ... 10 V Voltage 0.5 ... 4.5 V Current 4 ... 20 mA, 3 wire
<b>Measurement range</b>	0 ... 15° to 0 ... 360° (in 15° increments)
<b>Resolution</b>	0.03% (60 ... 360°); 0.1% (15 ... 45°)
<b>Repeatability</b>	±0.03% (60 ... 360°); ±0.1% (15 ... 45°)
<b>Linearity</b>	±0.5% f.s. (typical)
<b>Rated distance sensor / magnet</b>	Depending on the position magnet
<b>Protection class</b>	IP67
<b>Housing material</b>	Plastic
<b>Mounting</b>	Screws M4: DIN 912, DIN 6912, DIN 7984
<b>Connection</b>	Cable, standard length 2 m Cable with Deutsch connector DT04
<b>Temperature range</b>	-40 ... +85°C
<b>Shock</b>	DIN EN 60068-2-27:2010, 100 g/11 ms, 100 shocks
<b>Vibration</b>	DIN EN 60068-2-6:2008, 20 g 10 Hz-2 kHz, 10 cycles
<b>Weight</b>	20 g approx. (without cable)
<b>EMC</b>	DIN EN 61326-1:2013

## Order code

PRAS27 - 1 - 2 - 3 - 4

### 1 Measurement range (0 ... 15° to 0 ... 360°, in 15° increments)

15 / 30 / 45 / ... / 345 / 360

### 2 Output

<b>U2</b>	= Voltage 0.5 ... 10 V (excitation voltage 18 ... 36 V DC)
<b>U2B</b>	= Voltage 0.5 ... 10 V (excitation voltage 11.5 ... 27 V DC)
<b>U6</b>	= Voltage 0.5 ... 4.5 V ratiometric (excitation voltage 5 V DC)
<b>U8</b>	= Voltage 0.5 ... 4.5 V (excitation voltage 11 ... 36 V DC)
<b>I1</b>	= Current 4 ... 20 mA, 3 wire (excitation voltage 18 ... 36 V DC)
<b>I1B</b>	= Current 4 ... 20 mA, 3 wire (excitation voltage 10 ... 27 V DC)

### 3 Signal characteristics

<b>CW</b>	= Signal increasing CW, clockwise
<b>CCW</b>	= Signal increasing CCW, counterclockwise

### 4 Connection

<b>KAB2M</b>	= Cable, standard length 2 m
<b>KAB2M-DT04/3P/A*</b>	= Cable 2 m with Deutsch connector DT04, 3 pin
<b>KAB2M-DT04/3P/A-S*</b>	= Cable 2 m with Deutsch connector DT04, 3 pin, with protective tube
<b>KAB2M-DT04/4P/A</b>	= Cable 2 m with Deutsch connector DT04, 4 pin
<b>KAB2M-DT04/4P/A-S</b>	= Cable 2 m with Deutsch connector DT04, 4 pin, with protective tube

\* only for output U6

## Order example

PRAS27 - 360 - U6 - CW - KAB2M

## Accessories:

**Position magnets (see from page 9)**

**Magnetic shield (see page 19)**

## Analog output, redundant

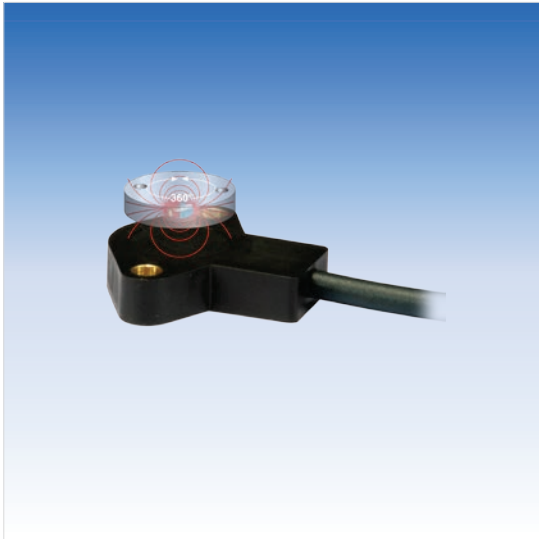

### Sensor features

- Measurement range 0 ... 360°
- Protection class IP67
- Analog output, redundant
- Compact, low profile housing
- Non-contact with external position magnet, no wear
- Housing: Plastic

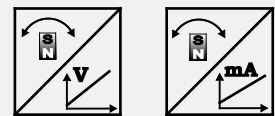

### Specifications

<b>Output</b>	Voltage 0.5 ... 10 V, redundant Voltage 0.5 ... 4.5 V, redundant Current 4 ... 20 mA, 3 wire, redundant
<b>Measurement range</b>	0 ... 15° to 0 ... 360° (in 15° increments)
<b>Resolution</b>	0.03% (60 ... 360°); 0.1% (15 ... 45°)
<b>Repeatability</b>	±0.03% (60 ... 360°); ±0.1% (15 ... 45°)
<b>Linearity</b>	±0.5% f.s. (typical)
<b>Rated distance sensor / magnet</b>	Depending on the position magnet
<b>Protection class</b>	IP67
<b>Housing material</b>	Plastic
<b>Mounting</b>	Screws M4: DIN 912, DIN 6912, DIN 7984
<b>Connection</b>	Cable, standard length 2 m Cable with Deutsch connector DT04
<b>Temperature range</b>	-40 ... +85°C
<b>Shock</b>	DIN EN 60068-2-27:2010, 100 g/11 ms, 100 shocks
<b>Vibration</b>	DIN EN 60068-2-6:2008, 20 g 10 Hz-2 kHz, 10 cycles
<b>Weight</b>	20 g approx. (without cable)
<b>EMC</b>	DIN EN 61326-1:2013

## Order code

PRAS27 - 1 - 2 - 3 - 4

### 1 Measurement range (0 ... 15° to 0 ... 360°, in 15° increments)

15 / 30 / 45 / ... / 345 / 360

### 2 Output

**U2R** = Voltage 0.5 ... 10 V, redundant (excitation voltage 18 ... 36 V DC)  
**U8R** = Voltage 0.5 ... 4.5 V, redundant (excitation voltage 11 ... 36 V DC)  
**I1R** = Current 4... 20 mA, 3 wire, redundant (excitation voltage 18 ... 36 V DC)  
(output I1R possible only with CW/CCW signal characteristics)

### 3 Signal characteristics

**CW/CCW** = Signal 1 increasing clockwise, signal 2 increasing counterclockwise  
**CW/CW\*** = Signal 1 and signal 2 increasing clockwise  
**CCW/CCW\*** = Signal 1 and signal 2 increasing counterclockwise

\* not available with output I1R

### 4 Connection

**KAB2M** = Cable, standard length 2 m  
**KAB2M-DT04/6P/A\*** = Cable 2 m with Deutsch connector DT04, 6 pin  
**KAB2M-DT04/6P/A-S\*** = Cable 2 m with Deutsch connector DT04, 6 pin, with protective tube

\* only for output U6R

## Order example

PRAS27 - 360 - U2R - CW/CCW - KAB2M

## Accessories:

**Position magnets (see from page 9)**

**Magnetic shield (see page 19)**

## Dimensions

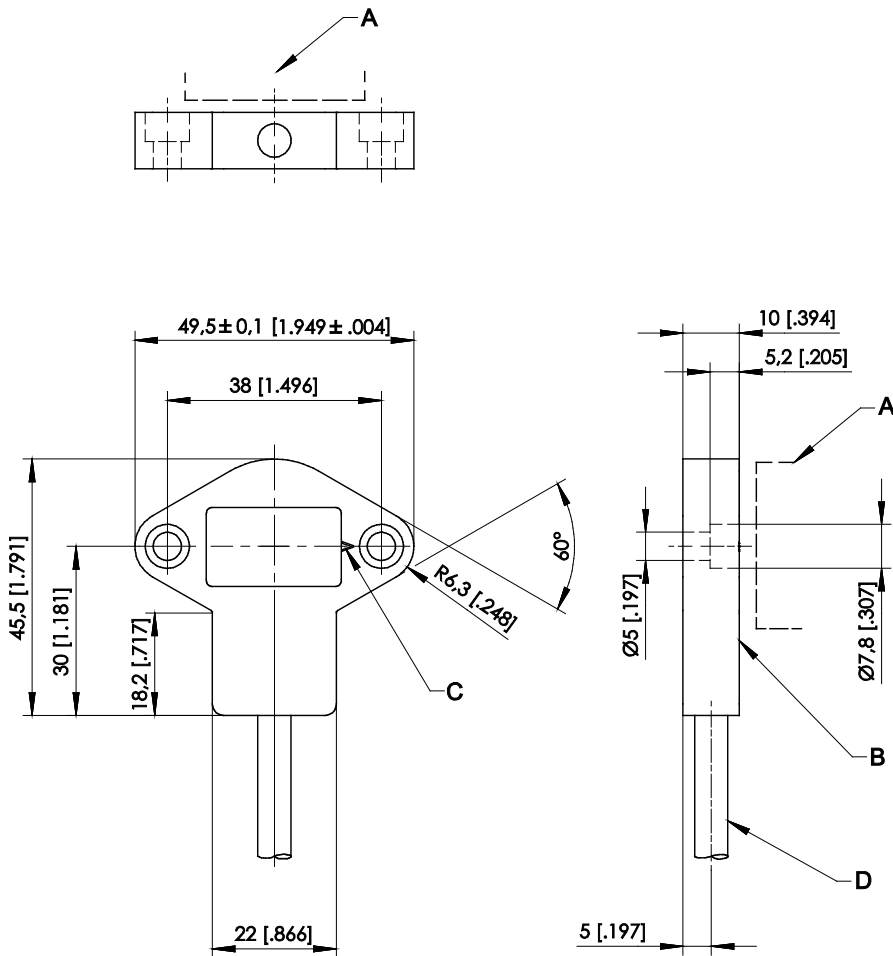

- A – Position magnet
- B – Measuring area
- C – Marking
- D – Cable

Dimensions in mm [inch].  
Dimensions informative only.  
For guaranteed dimensions consult factory.



## Position magnets

### PRMAG20

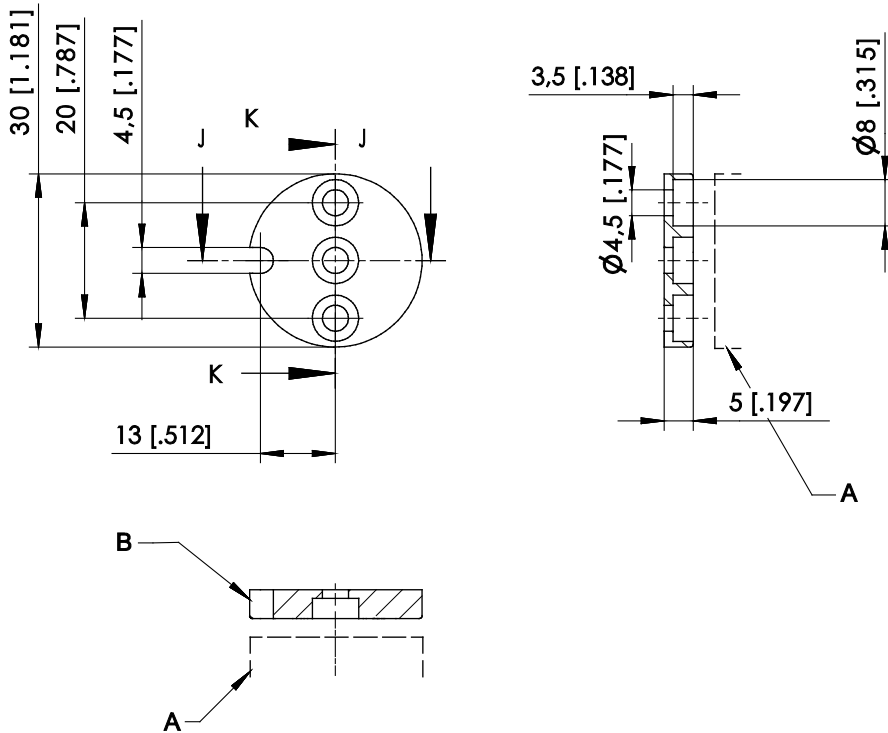

A – Sensor  
B – Marking

Order code	Weight	Material	Moment of inertia
PRMAG20	approx. 12 g	zinc coated steel, plastic	1.3 kgmm <sup>2</sup>

A misalignment of the position magnet has an effect on the linearity.

Dimensions in mm [inch].

Dimensions informative only.

For guaranteed dimensions please consult factory.

**PRMAG21**

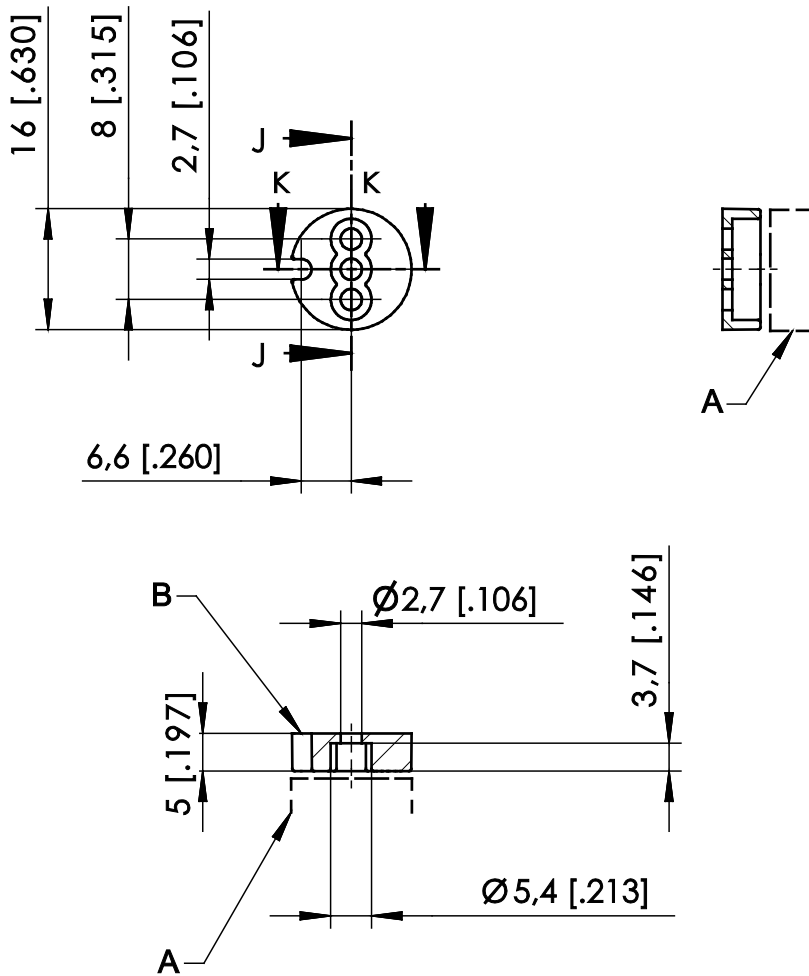

A – Sensor  
B – Marking

Order code	Weight	Material	Moment of inertia
<b>PRMAG21</b>	approx. 3 g	zinc coated steel; plastic	0.1 kgmm <sup>2</sup>

A misalignment of the position magnet has an effect on the linearity.

Dimensions in mm [inch]

Dimensions informative only.

For guaranteed dimensions please consult factory.

**PRMAG22**

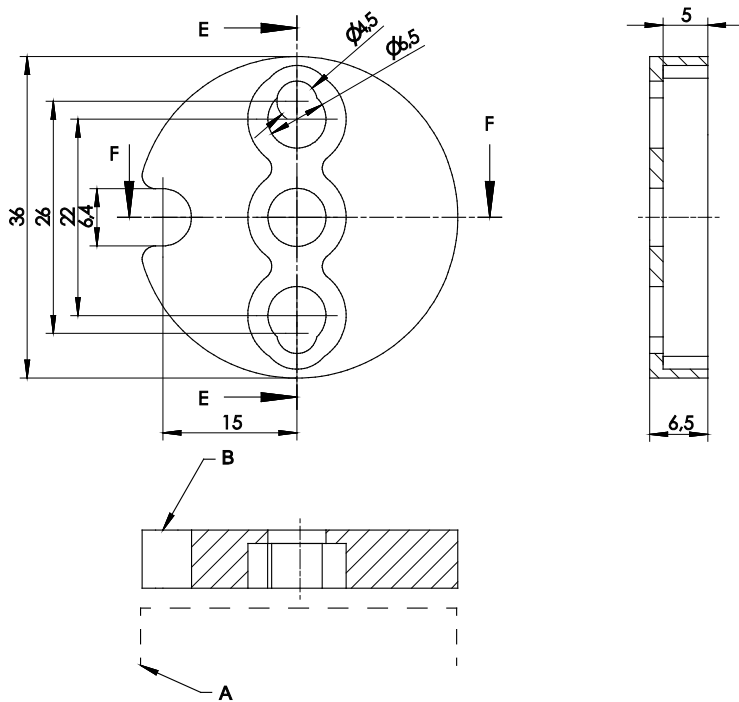

A – Sensor  
B – Marking

Order code	Weight	Material	Moment of inertia
PRMAG22	approx. 19 g	zinc coated steel, plastic	3 kgmm <sup>2</sup>

A misalignment of the position magnet has an effect on the linearity.

Dimensions in mm [inch].  
Dimensions informative only  
For guaranteed dimensions please consult factory.

**PRMAG-M10**

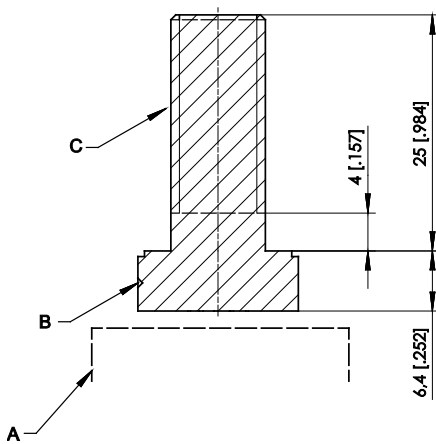
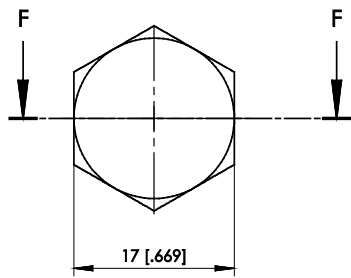

- A – Sensor
- B – Marking
- C – Thread M10

Order code	Weight	Material	Moment of inertia
<b>PRMAG-M10</b>	approx. 30 g	stainless steel A2	1.3 kgmm <sup>2</sup>

A misalignment of the position magnet has an effect on the linearity.

Dimensions in mm [inch].

Dimensions informative only.

For guaranteed dimensions please consult factory.

## Output specification

### Analog output

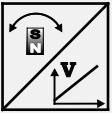
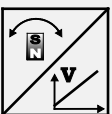
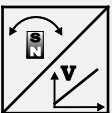
<b>U2</b> Voltage output 0.5 ... 10 V 	Excitation voltage	18 ... 36 V DC
	Excitation current	typical 10 mA max. 15 mA
	Output voltage	0.5 ... 10 V DC
	Output current	2 mA max.
	Measuring rate	1 kHz standard
	Stability (temperature)	$\pm 50 \times 10^{-6} / ^\circ\text{C}$ f.s. (typical for $90^\circ \dots 360^\circ$ ) $\pm 100 \times 10^{-6} / ^\circ\text{C}$ f.s. (typical for $<90^\circ$ )
	Protection	Reverse polarity, short circuit
	Operating temperature	-40 ... +85 °C
	EMC	DIN EN 61326-1:2013
<b>U2B</b> Voltage output 0.5 ... 10 V 	Excitation voltage	11.5 ... 27 V DC
	Excitation current	typical 12 mA max. 16 mA
	Output voltage	0,5 ... 10 V DC
	Output current	2 mA max.
	Measuring rate	1 kHz standard
	Stability (temperature)	$\pm 50 \times 10^{-6} / ^\circ\text{C}$ f.s. (typical for $90^\circ \dots 360^\circ$ ) $\pm 100 \times 10^{-6} / ^\circ\text{C}$ f.s. (typical for $<90^\circ$ )
	Protection	Reverse polarity, short circuit
	Operating temperature	-40 ... +85 °C
	EMC	DIN EN 61326-1:2013
<b>U6</b> Voltage output 10 ... 90 % ratiometric 	Excitation voltage	5 V DC $\pm 10\%$
	Excitation current	typical 8 mA max. 12 mA
	Output voltage	10 ... 90 % of the excitation voltage
	Output current	2 mA max.
	Measuring rate	1 kHz standard
	Stability (temperature)	$\pm 50 \times 10^{-6} / ^\circ\text{C}$ f.s. (typical for $90^\circ \dots 360^\circ$ ) $\pm 100 \times 10^{-6} / ^\circ\text{C}$ f.s. (typical for $<90^\circ$ )
	Protection	Reverse polarity, short circuit
	Operating temperature	-40 ... +85 °C
	EMC	DIN EN 61326-1:2013

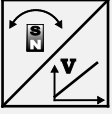
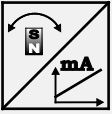
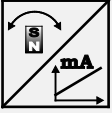
<b>U8</b> Voltage output 0.5 ... 4.5 V 	Excitation voltage	11 ... 36 V DC
	Excitation current	typical 10 mA max. 20 mA
	Output voltage	0.5 ... 4.5 V DC
	Output current	2 mA max.
	Measuring rate	1 kHz standard
	Stability (temperature)	$\pm 50 \times 10^{-6} / ^\circ\text{C}$ f.s. (typical for $90^\circ \dots 360^\circ$ ) $\pm 100 \times 10^{-6} / ^\circ\text{C}$ f.s. (typical for $<90^\circ$ )
	Protection	Reverse polarity, short circuit
	Operating temperature	-40 ... +85 °C
	EMC	DIN EN 61326-1:2013
<b>I1</b> Current output 4 ... 20 mA, 3 wires 	Excitation voltage	18 ... 36 V DC
	Excitation current	typical 30 mA max. 35 mA
	Load $R_L$	500 $\Omega$ max.
	Output current	4 ... 20 mA
	Measuring rate	1 kHz standard
	Stability (temperature)	$\pm 50 \times 10^{-6} / ^\circ\text{C}$ f.s. (typical for $90^\circ \dots 360^\circ$ ) $\pm 100 \times 10^{-6} / ^\circ\text{C}$ f.s. (typical for $<90^\circ$ )
	Protection	Reverse polarity, short circuit
	Operating temperature	-40 ... +85 °C
	EMC	DIN EN 61326-1:2013
<b>I1B</b> Current output 4 ... 20 mA, 3 wires 	Excitation voltage	10 ... 27 V DC
	Excitation current	typical 32 mA max. 36 mA
	Load $R_L$	250 $\Omega$ max.
	Output current	4 ... 20 mA
	Measuring rate	1 kHz standard
	Stability (temperature)	$\pm 50 \times 10^{-6} / ^\circ\text{C}$ f.s. (typical for $90^\circ \dots 360^\circ$ ) $\pm 100 \times 10^{-6} / ^\circ\text{C}$ f.s. (typical for $<90^\circ$ )
	Protection	Reverse polarity, short circuit
	Operating temperature	-40 ... +85 °C
	EMC	DIN EN 61326-1:2013

**Signal diagram**

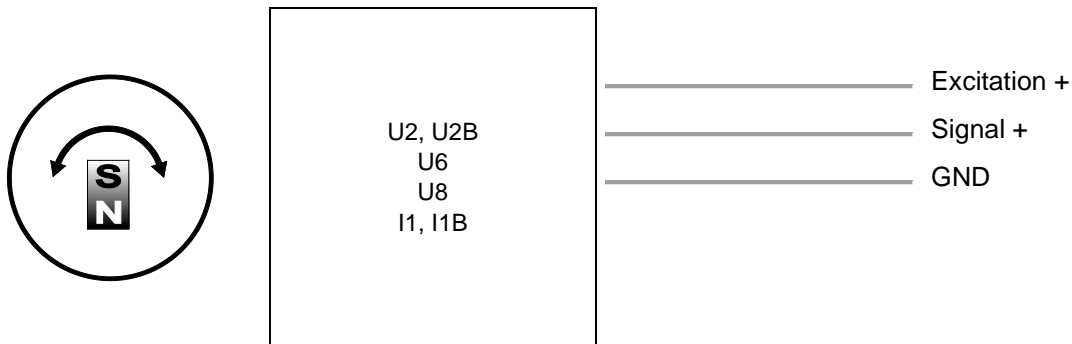

**Signal wiring  
(connector and cable output)**

Signal	Connector pin no.	Cable color	View to the sensor connector
Excitation +	1	brown	
Signal	2	white	
GND	3	blue	
Do not connect!	4	black	
Do not connect!	5	grey	

3-wire current 4...20 mA interface: GND has to be connected!

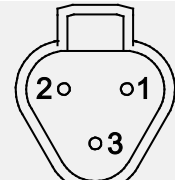
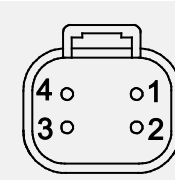
Deutsch connector DT04	 <b>DT04/3P/A</b>	 <b>DT04/4P/A</b>

## Analog output, redundant

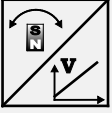
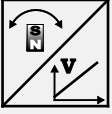
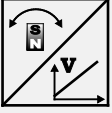
<b>U2R</b> Voltage output 0.5 ... 10 V 	Excitation voltage	18 ... 36 V DC
	Excitation current	typical 10 mA max. 15 mA per channel
	Output voltage	0.5 ... 10 V DC
	Output current	2 mA max.
	Measuring rate	1 kHz Standard
	Stability (temperature)	$\pm 50 \times 10^{-6} / ^\circ\text{C}$ f.s. (typical for $90^\circ \dots 360^\circ$ ) $\pm 100 \times 10^{-6} / ^\circ\text{C}$ f.s. (typical for $<90^\circ$ )
	Protection	Reverse polarity, short circuit
	Operating temperature	-40 ... +85 °C
	EMC	DIN EN 61326-1:2013
<b>U6R</b> Voltage output 10 ... 90 % ratiometric 	Excitation voltage	5 V DC $\pm 10\%$
	Excitation current	typical 8 mA max. 12 mA per channel
	Output voltage	10 ... 90 % of the excitation voltage
	Output current	2 mA max.
	Measuring rate	1 kHz standard
	Stability (temperature)	$\pm 50 \times 10^{-6} / ^\circ\text{C}$ f.s. (typical for $90^\circ \dots 360^\circ$ ) $\pm 100 \times 10^{-6} / ^\circ\text{C}$ f.s. (typical for $<90^\circ$ )
	Protection	Reverse polarity, short circuit
	Operating temperature	-40 ... +85 °C
	EMC	EN 61326-1:2013
<b>U8R</b> Voltage output 0.5 ... 4.5 V 	Excitation voltage	11 ... 36 V DC
	Excitation current	typical 10 mA max. 20 mA per channel
	Output voltage	0.5 ... 4,5 V DC
	Output current	2 mA max.
	Measuring rate	1 kHz standard
	Stability (temperature)	$\pm 50 \times 10^{-6} / ^\circ\text{C}$ f.s. (typical for $90^\circ \dots 360^\circ$ ) $\pm 100 \times 10^{-6} / ^\circ\text{C}$ f.s. (typical for $<90^\circ$ )
	Protection	Reverse polarity, short circuit
	Operating temperature	-40 ... +85 °C
	EMC	DIN EN 61326-1:2013

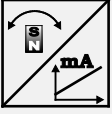

<b>I1R</b> Current output 4 ... 20 mA, 3 wires 	Excitation voltage	18 ... 36 V DC
	Excitation current	typical 30 mA max. 35 mA per channel
	Load R <sub>L</sub>	500 Ω max.
	Output current	4 ... 20 mA
	Measuring rate	1 kHz standard
	Stability (temperature)	±50 x 10 <sup>-6</sup> / °C f.s. (typical for 90° ... 360°) ±100 x 10 <sup>-6</sup> / °C f.s. (typical for <90°)
	Protection	Reverse polarity, short circuit
	Operating temperature	-40 ... +85 °C
	EMC	DIN EN 61326-1:2013

**Signal diagram**

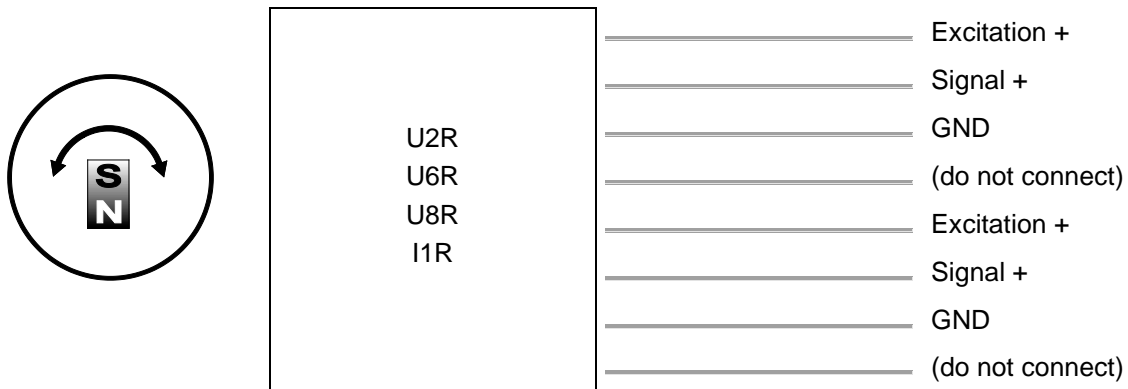

**Signal wiring**

**2 channels, redundant (connector and cable output)**

Channel	Signal	Connector pin no.	Cable color	View to the sensor connector
1	Excitation +	1	white	
1	Signal	2	brown	
1	GND	3	green	
1	Do not connect!	4	yellow	
2	Excitation +	5	grey	
2	Signal	6	pink	
2	GND	7	blue	
2	Do not connect!	8	red	

**Deutsch connector DT04/6P/A**

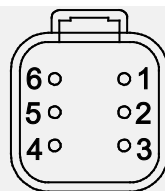

## Characteristics for magnetic angle sensors

**Output signal CW**  
(clockwise increasing)

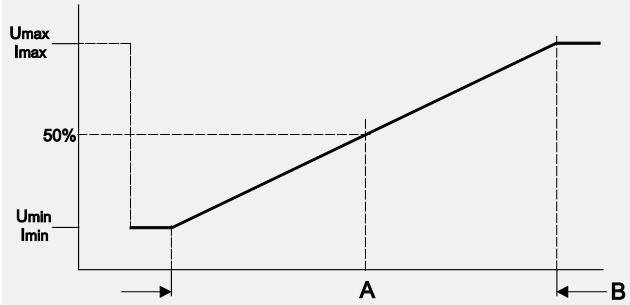

**Output signal CCW**  
(counterclockwise increasing)

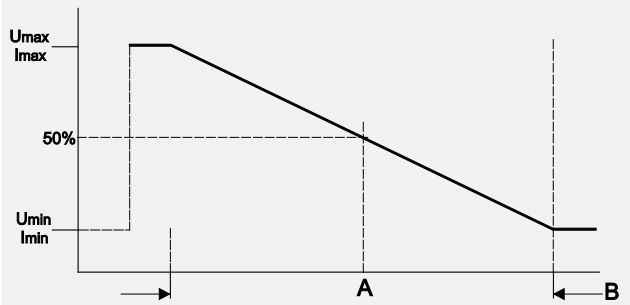

Example angular range 90°

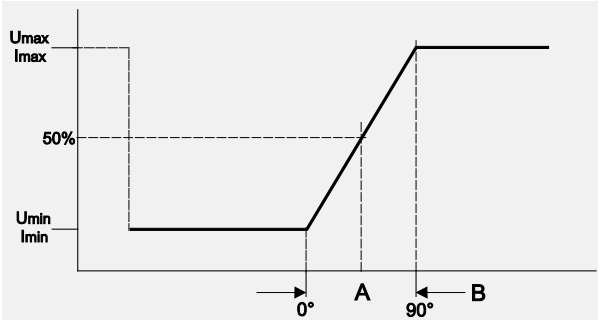

Example angular range 360°

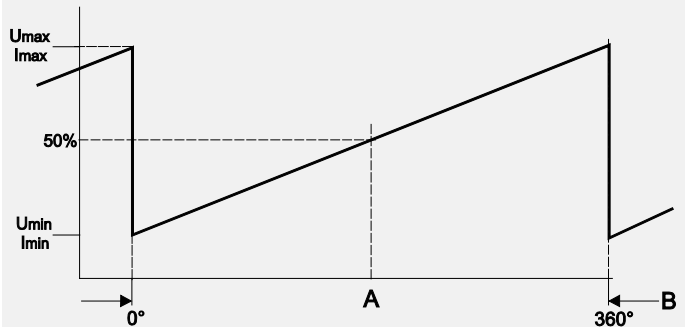

A – Marking  
B – Measurement range [°]

## Accessories

### PRAS27 Magnetic Shield

An optional shield plate is available for the angle sensors PRAS27 and PRDS27. It can reduce the effect of residual magnetizing in case the sensor has to be mounted on a ferromagnetic material.

Order code magnetic shield:

**PRAS27-MSHIELD**

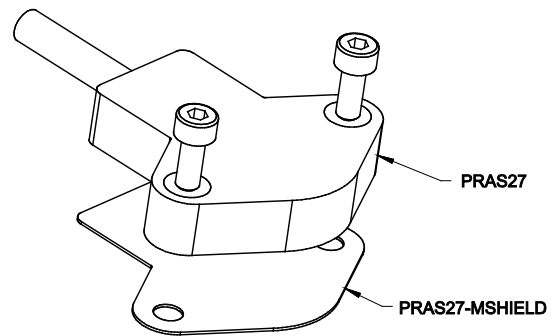

## Deutsch connector

Sensors with cable output can be delivered with Deutsch connector.

- Protection class: IP67 (while plugged)
- Connection: 3, 4, 6, 8 poles – depending on output, see table below
- Wire cross sectional area: 0.5 mm<sup>2</sup>
- Standard cable length: 2 m
- Protective cable tube: for a better mechanical protection the cable can be delivered with a protective tube

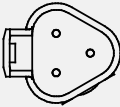
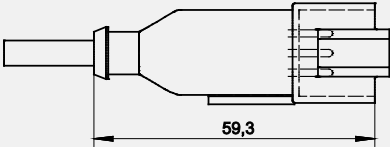
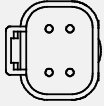
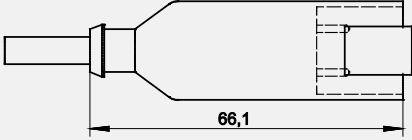
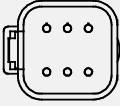
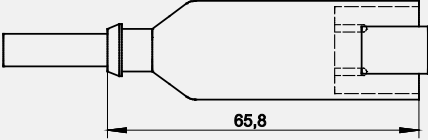
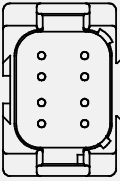
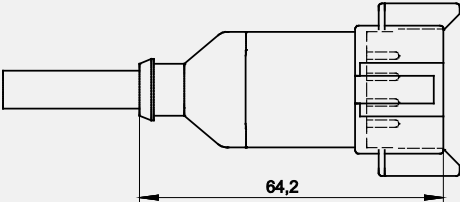

### Deutsch connector – table

Number of poles	Deutsch connector DT04		Output
3 pin			U6
4 pin			U2, U2B, U8 I1, I1B CANOP(R), CANJ1939(R)
6 pin			U6R RSSI5V RSSI24V
8 pin			U2R, U8R I1R RS5VF, RS24VF HT24VF

# POSIROT<sup>®</sup>

Magnetic Angle Encoders

**PRDS27**  
**Magnetic Angle Encoder**

Datasheet

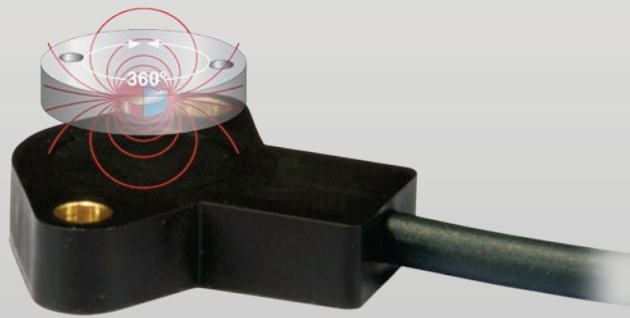

### **Copyright**

© ASM GmbH  
Am Bleichbach 18-24  
85452 Moosinning  
Germany

The information presented in this data sheet does not form part of any quotation or contract, is believed to be accurate and reliable and may be changed without notice. No liability will be accepted by ASM for any consequence of its use. Publication thereof does not convey nor imply any license under patent or industrial or intellectual property rights. Applications that are described herein for any of these products are for illustrative purpose only.

ASM makes no representation or warranty that such applications will be suitable for the specified use without further testing or modification.

<b>PRDS27</b> .....	<b>4</b>
Digital output CAN.....	4
Specifications .....	4
Order code .....	5
Dimensions .....	6
Position magnets.....	7
<b>Output specification</b> .....	<b>11</b>
Digital output CANopen.....	11
Digital output CAN SAE J1939 .....	13
<b>Characteristics for magnetic angle sensors</b> .....	<b>17</b>
<b>Accessories</b> .....	<b>18</b>
PRAS27 Magnetic Shield.....	18
<b>Deutsch connector</b> .....	<b>19</b>

## PRDS27

### Digital output CAN

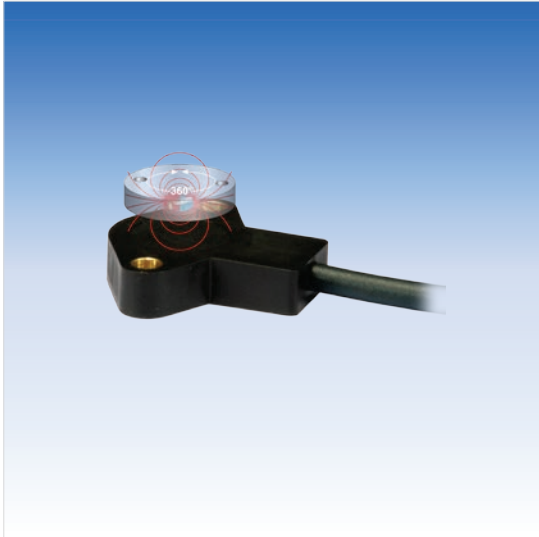

#### Sensor features

- Measurement range 0 ... 360°
- Protection class IP67
- Digital output CAN
- Non-contact with external position magnet, no wear
- Housing: Plastic
- Redundant version available



#### Specifications

<b>Output</b>	CANopen (CiA 301-V4.02/406-V3.2) CAN SAE J1939
<b>Measurement range</b>	0 ... 360°
<b>Resolution</b>	0.05° max.
<b>Linearity</b>	±1% (typical)
<b>Rated distance sensor / magnet</b>	Depending on the position magnet
<b>Protection class</b>	IP67
<b>Housing material</b>	Plastic
<b>Mounting</b>	Screws M4: DIN 912, DIN 6912, DIN 7984
<b>Connection</b>	Cable 0.3 m, 5-pin connector M12 Cable with Deutsch connector DT04
<b>Temperature range</b>	-40 ... +85°C
<b>Shock</b>	DIN EN 60068-2-27:2010, 100 g/11 ms, 100 shocks
<b>Vibration</b>	DIN EN 60068-2-6:2008, 20 g 10 Hz-2 kHz, 10 cycles
<b>Weight</b>	20 g approx. (without cable)
<b>EMC</b>	DIN EN 61326-1:2013



**Order code**

PRDS27 - 1 - 2

**1 Output**

<b>CANOP</b>	= CANopen
<b>CANJ1939</b>	= CAN SAE J1939
<b>CANOPR</b>	= CANopen, redundant
<b>CANJ1939R</b>	= CAN SAE J1939, redundant

**2 Connection**

<b>KAB0,3M-M12/CAN</b>	= Cable 0.3 m with connector M12, 5 pin
<b>KAB0,3M-DT04/4P/A</b>	= Cable 0.3 m with Deutsch connector DT04, 4 pin
<b>KAB0,3M-DT04/4P/A-S</b>	= Cable 0.3 m with Deutsch connector DT04, 4 pin, with protective tube

**Order example**

**PRDS27 - CANOP - KAB0,3M - DT04/4P/A**

**Accessories:**

**Position magnets (see from page 7)**

**Magnetic shield (see page 18)**

**Dimensions**

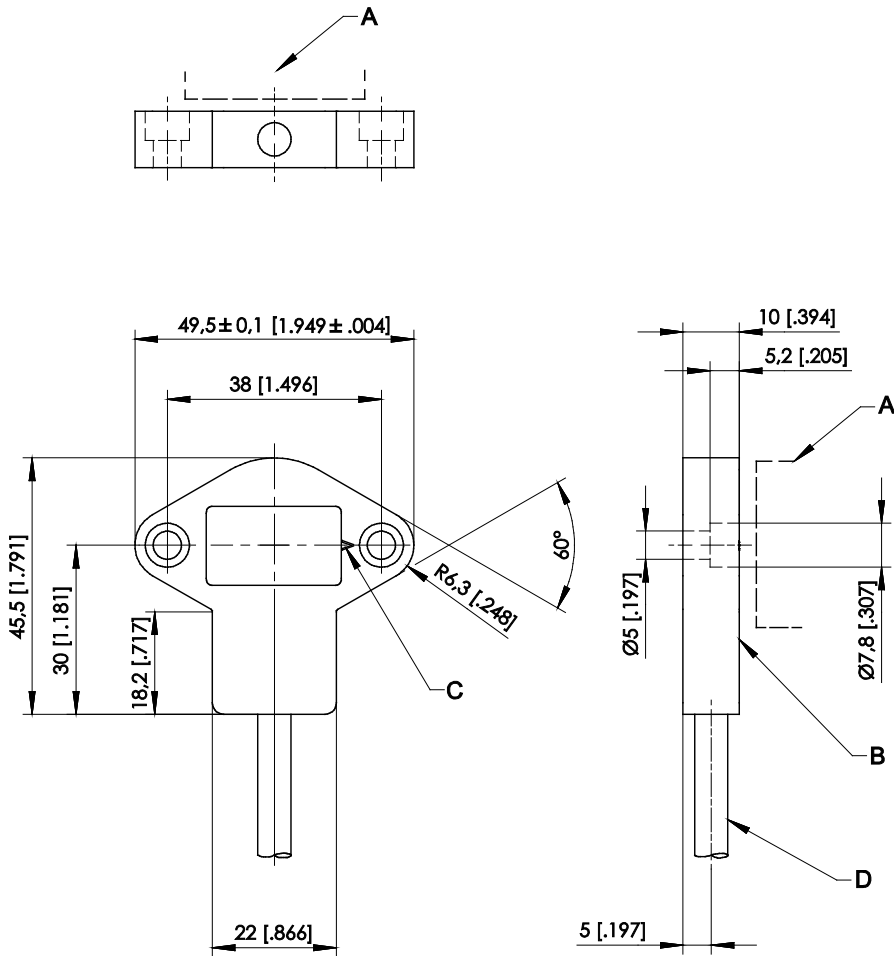

- A – Position magnet
- B – Measuring area
- C – Marking
- D – Cable

Dimensions in mm [inch].  
Dimensions informative only.  
For guaranteed dimensions consult factory.

**Position magnets**

**PRMAG20**

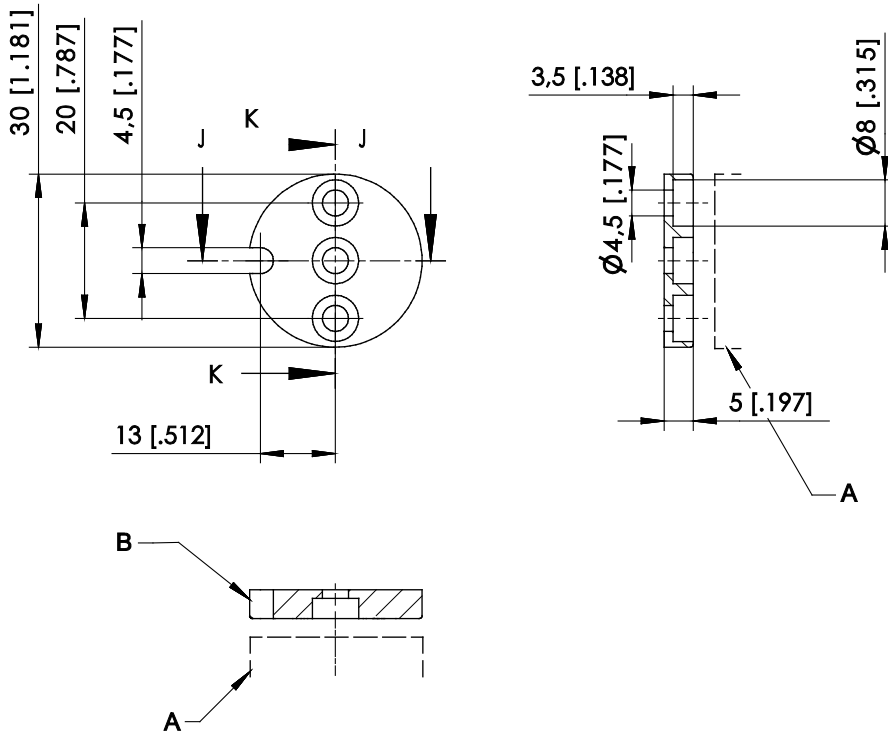

A – Sensor  
B – Marking

Order code	Weight	Material	Moment of inertia
PRMAG20	approx. 12 g	zinc coated steel, plastic	1.3 kgmm <sup>2</sup>

A misalignment of the position magnet has an effect on the linearity.

Dimensions in mm [inch].  
Dimensions informative only.  
For guaranteed dimensions please consult factory.

**PRMAG21**

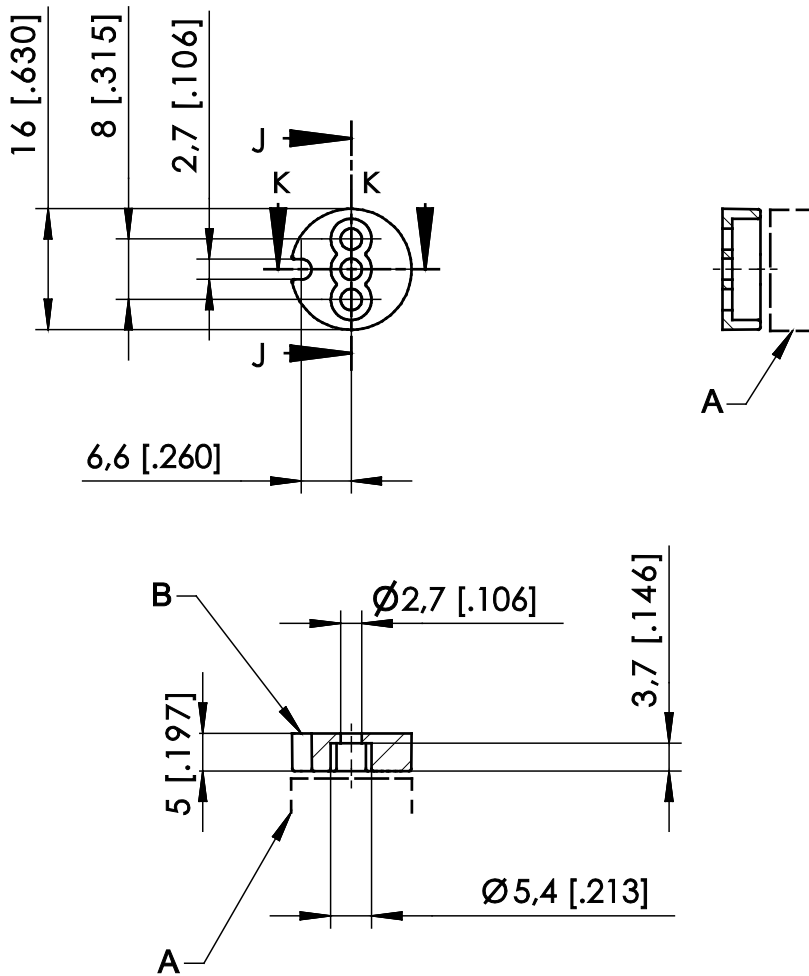

A – Sensor  
B – Marking

Order code	Weight	Material	Moment of inertia
<b>PRMAG21</b>	approx. 3 g	zinc coated steel; plastic	0.1 kgmm <sup>2</sup>

A misalignment of the position magnet has an effect on the linearity.

Dimensions in mm [inch]

Dimensions informative only.

For guaranteed dimensions please consult factory.

**PRMAG22**

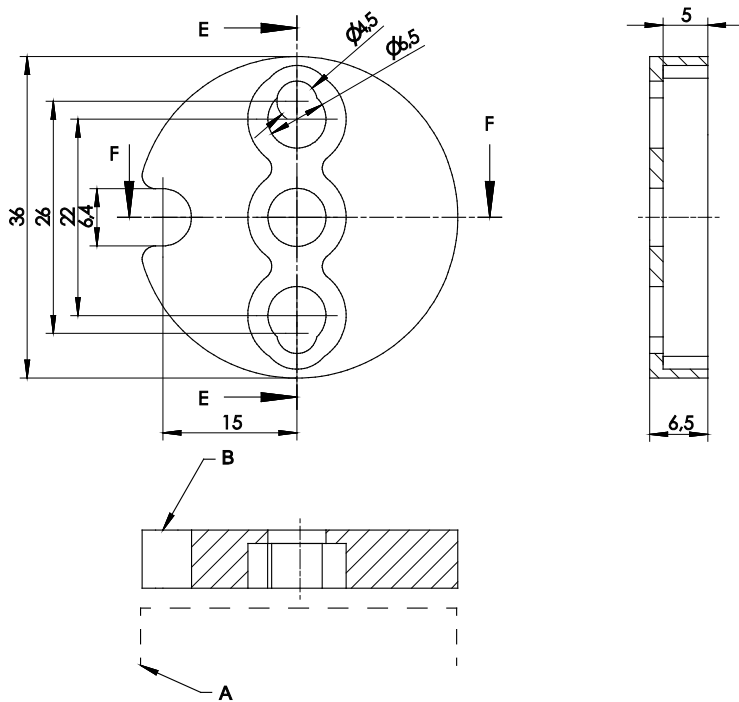

A – Sensor  
B – Marking

Order code	Weight	Material	Moment of inertia
<b>PRMAG22</b>	approx. 19 g	zinc coated steel, plastic	3 kgmm <sup>2</sup>

A misalignment of the position magnet has an effect on the linearity.

Dimensions in mm [inch].  
Dimensions informative only  
For guaranteed dimensions please consult factory.

**PRMAG-M10**

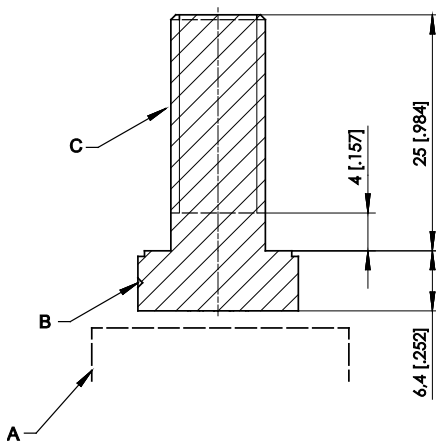
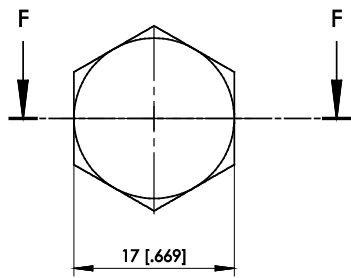

A – Sensor  
B – Marking  
C – Thread M10

Order code	Weight	Material	Moment of inertia
<b>PRMAG-M10</b>	approx. 30 g	stainless steel A2	1.3 kgmm <sup>2</sup>

A misalignment of the position magnet has an effect on the linearity.

Dimensions in mm [inch].  
Dimensions informative only.  
For guaranteed dimensions please consult factory.

## Output specification

### Digital output CANopen

<b>CANOP</b> CANopen 	CAN Specification	ISO 11898, Basic and Full CAN 2.0 B
	Communication profile	CANopen CiA 301 V 4.02, Slave
	Device profile	Encoder CiA 406 V 3.2
	Configuration services	Layer Setting Service (LSS), CiA Draft Standard 305 (transmission rate, node id)
	Error Control	Node Guarding, Heartbeat, Emergency Message
	Node ID	Default: 127; programmable via LSS or SDO
	PDO	3 TxPDO, 0 RxPDO, static mapping
	PDO Modes	Event-/Time triggered, Remote-request, Sync cyclic/acyclic
	SDO	1 server, 0 Client
	CAM	8 cams
	Certified	Yes
	Transmission rates	50 kBaud to 1 MBaud, default: 125 kBaud; programmable via LSS or SDO
	Bus connection	M12 connector, 5 pin
	Integrated bus terminating resistor	Adjustable by the customer
Bus, galvanic isolated	No	

<b>Specifications</b>	Excitation voltage	8 ... 36 V DC
	Excitation current	20 mA typical at 24 V DC 40 mA typical at 12 V DC, 80 mA max.
	Resolution	0.05° max.
	Linearity	1° (optional 0.25°)
	Measuring rate	1 kHz (asynchronous)
	Stability (temperature)	±50 x 10 <sup>-6</sup> /°C f.s. (typical)
	Repeatability	1 LSB
	Operating temperature	See specification of the respective sensor
	Protection	Reverse polarity, short circuit
	Dielectric strength	1 kV (V AC, 50 Hz, 1 min.)
	EMC	DIN EN 61326-1:2013

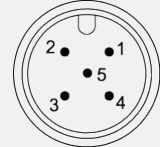
Signal wiring	Signal	Connector pin no.	Cable color	View to the sensor connector
	Shield	1	brown	
	Excitation +	2	white	
	GND	3	blue	
	CAN-H	4	black	
	CAN-L	5	grey	

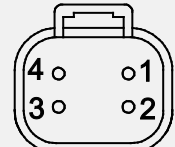
Signal wiring Deutsch connector DT04/4P/A	Signal	Connector pin no.	View to the sensor connector
	Excitation+	1	
	CAN-H	2	
	GND	3	
	CAN-L	4	

<b>CANOPR</b> CANopen 	CAN Specification	ISO 11898, Basic and Full CAN 2.0 B
	Communication profile	CANopen CiA 301 V 4.02, Slave
	Device profile	Encoder CiA 406 V 3.2
	Configuration services	Layer Setting Service (LSS), CiA Draft Standard 305 (transmission rate, node id)
	Error Control	Node Guarding, Heartbeat, Emergency Message
	Node ID	Default: 127 and 126; programmable via LSS or SDO
	PDO	3 TxPDO, 0 RxPDO, static mapping
	PDO Modes	Event-/Time triggered, Remote-request, Sync cyclic/acyclic
	SDO	1 server, 0 Client
	CAM	8 cams
	Certified	Yes
	Transmission rates	50 kBaud to 1 MBaud, default: 125 kBaud; programmable via LSS or SDO
	Bus connection	M12 connector, 5 pin
	Integrated bus terminating resistor	adjustable by the customer
Bus, galvanic isolated	No	

<b>Specifications</b>	Excitation voltage	8 ... 36 V DC
	Excitation current	40 mA typical at 24 V DC 80 mA typical at 12 V DC, 120 mA max.
	Resolution	0.05° max.
	Linearity	1° (0.25° optional)
	Measuring rate	1 kHz (asynchronous)
	Stability (temperature)	±50 x 10 <sup>-6</sup> /°C f.s. (typical)
	Repeatability	1 LSB
	Operating temperature	See specification of the respective sensor
	Protection	Reverse polarity, short circuit
	Dielectric strength	1 kV (V AC, 50 Hz, 1 min.)
	EMC	DIN EN 61326-1:2013

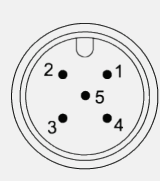
Signal wiring	Signal	Connector pin no.	Cable color	View to the sensor connector
	Shield	1	brown	
	Excitation +	2	white	
	GND	3	blue	
	CAN-H	4	black	
	CAN-L	5	grey	

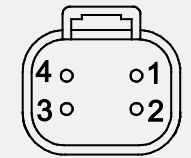
Signal wiring Deutsch connector DT04/4P/A	Signal	Connector pin no.	View to the sensor connector
	Excitation+	1	
	CAN-H	2	
	GND	3	
	CAN-L	4	



## Digital output CAN SAE J1939

<b>CANJ1939</b> CAN SAE J1939 	CAN Specification	ISO 11898, Basic and Full CAN 2.0 B
	Transceiver	24V-compliant, not isolated
	Communication profile	SAE J1939
	Baud Rate	250 kbit/s
	Internal termination resistor	adjustable by the customer
	Address	Default 247d, configurable

<b>NAME Fields</b>	Arbitrary address capable	1	Yes
	Industry group	0	Global
	Vehicle system	7Fh (127d)	Non specific
	Vehicle system instance	0	
	Function	FFh (255d)	Non specific
	Function instance	0	
	ECU instance	0	
	Manufacturer	145h (325d)	Manufacturer ID
	Identity number	0nnn	Serial number 21 bit

<b>Parameter Group Numbers (PGN)</b>	Configuration data	PGN EF00h	Proprietary-A (PDU1 peer-to-peer)
	Process data	PGN FFnnh	Proprietary-B (PDU2 broadcast); nn Group Extension (PS) configurable

<b>Specifications</b>	Excitation voltage	8 ... 36 V DC
	Excitation current	20 mA typical at 24 V DC 40 mA typical at 12 V DC, 80 mA max.
	Resolution	0.05° max.
	Linearity	1° (0.25° optional)
	Measuring rate	1 kHz (asynchronous)
	Stability (temperature)	±50 x 10 <sup>-6</sup> /°C f.s. (typical)
	Repeatability	1 LSB
	Operating temperature	See specification of the respective sensor
	Protection	Reverse polarity, short circuit
	Dielectric strength	1 kV (V AC, 50 Hz, 1 min.)
	EMV	DIN EN 61326-1:2013

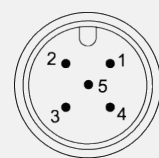
Signal wiring	Signal	Connector pin no.	View to the sensor connector
	Shield	1	
	Excitation +	2	
	GND	3	
	CAN-H	4	
	CAN-L	5	

<b>Signal wiring</b> <b>Deutsch connector</b> <b>DT04/4P/A</b>	<b>Signal</b>	<b>Connector pin no.</b>	<b>View to the sensor connector</b>
	Excitation+	1	
	CAN-H	2	
	GND	3	
	CAN-L	4	

<b>CANJ1939R</b> CAN SAE J1939 	CAN Specification	ISO 11898, Basic and Full CAN 2.0 B
	Transceiver	24V-compliant, not isolated
	Communication profile	SAE J1939
	Baud Rate	250 kbit/s
	Internal termination resistor	Adjustable by the customer
	Address	Default 247d and 246d, configurable

<b>NAME Fields</b>	Arbitrary address capable	1	Yes
	Industry group	0	Global
	Vehicle system	7Fh (127d)	Non specific
	Vehicle system instance	0	
	Function	FFh (255d)	Non specific
	Function instance	0	
	ECU instance	0	
	Manufacturer	145h (325d)	Manufacturer ID
	Identity number	0nnn	Serial number 21 bit

<b>Parameter Group Numbers (PGN)</b>	Configuration data	PGN EF00h	Proprietary-A (PDU1 peer-to-peer)
	Process data	PGN FFnnh	Proprietary-B (PDU2 broadcast); nn Group Extension (PS) configurable

<b>Specifications</b>	Excitation voltage	8 ... 36 V DC
	Excitation current	40 mA typical at 24 V DC 80 mA typical at 12 V DC, 120 mA max.
	Resolution	0.05° max.
	Linearity	1° (0.25° optional)
	Measuring rate	1 kHz (asynchronous)
	Stability (temperature)	±50 x 10 <sup>-6</sup> /°C f.s. (typical)
	Repeatability	1 LSB
	Operating temperature	See specification of the respective sensor
	Protection	Reverse polarity, short circuit
	Dielectric strength	1 kV (V AC, 50 Hz, 1 min.)
EMV	DIN EN 61326-1:2013	

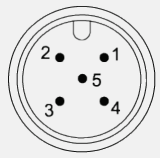
Signal wiring	Signal	Connector Pin no.	Cable color	View to the sensor connector
	Shield	1	brown	
	Excitation +	2	white	
	GND	3	blue	
	CAN-H	4	black	
	CAN-L	5	grey	

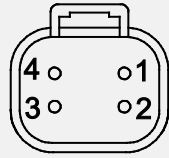
<b>Signal wiring</b> <b>Deutsch connector</b> <b>DT04/4P/A</b>	<b>Signal</b>	<b>Connector pin no.</b>	<b>View to the sensor connector</b>
	Excitation+	1	
	CAN-H	2	
	GND	3	
	CAN-L	4	

## Characteristics for magnetic angle sensors

**Output signal CW**  
(clockwise increasing)

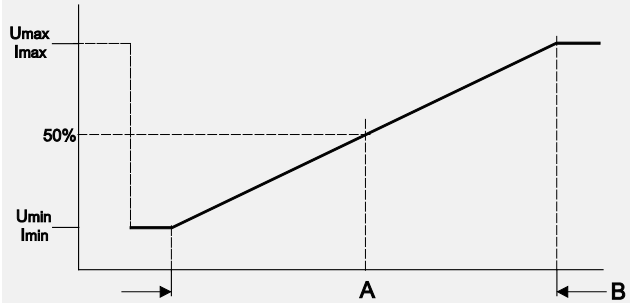

**Output signal CCW**  
(counterclockwise increasing)

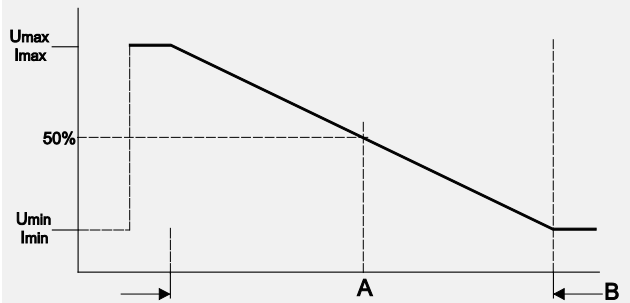

Example angular range 90°

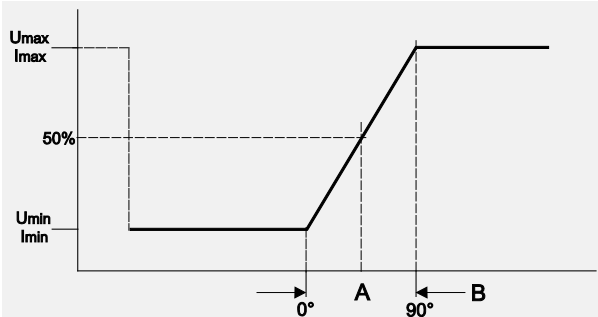

Example angular range 360°

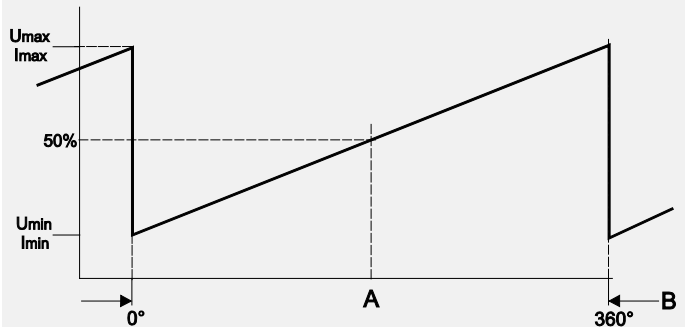

A – Marking  
B – Measurement range [°]

## Accessories

### PRAS27 Magnetic Shield

An optional shield plate is available for the angle sensors PRAS27 and PRDS27. It can reduce the effect of residual magnetizing in case the sensor has to be mounted on a ferromagnetic material.

Order code magnetic shield:

**PRAS27-MSHIELD**

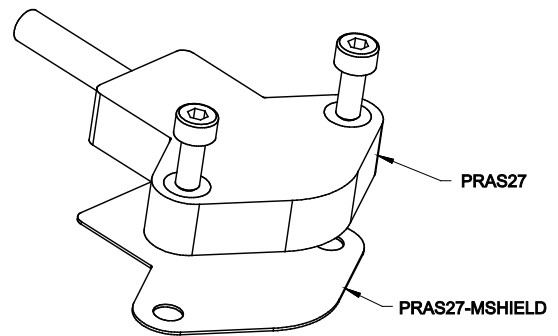

## Deutsch connector

Sensors with cable output can be delivered with Deutsch connector.

- Protection class: IP67 (while plugged)
- Connection: 3, 4, 6, 8 poles – depending on output, see table below
- Wire cross sectional area: 0.5 mm<sup>2</sup>
- Standard cable length: 2 m
- Protective cable tube: for a better mechanical protection the cable can be delivered with a protective tube

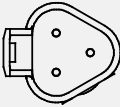
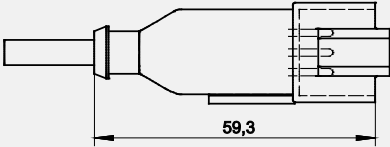
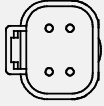
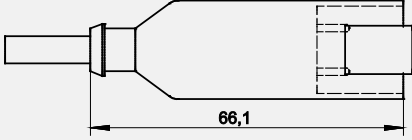
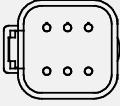
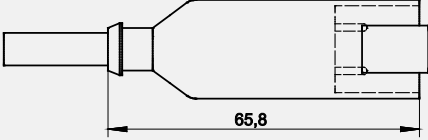
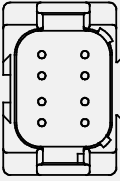
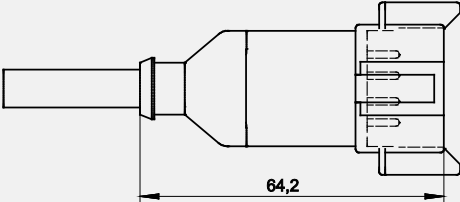

### Deutsch connector – table

Number of poles	Deutsch connector DT04		Output
3 pin			U6
4 pin			U2, U2B, U8 I1, I1B CANOP(R), CANJ1939(R)
6 pin			U6R RSSI5V RSSI24V
8 pin			U2R, U8R I1R RS5VF, RS24VF HT24VF