

POSIROT[®]

Magnetic Angle Sensors

PRAS7
Magnetic Angle Sensor

Datasheet



Copyright

© ASM GmbH
Am Bleichbach 18-24
85452 Moosinning
Germany

The information presented in this data sheet does not form part of any quotation or contract, is believed to be accurate and reliable and may be changed without notice. No liability will be accepted by ASM for any consequence of its use. Publication thereof does not convey nor imply any license under patent or industrial or intellectual property rights. Applications that are described herein for any of these products are for illustrative purpose only.

ASM makes no representation or warranty that such applications will be suitable for the specified use without further testing or modification.

Analog output	4
Specifications	4
Order code	5
Analog output, redundant	6
Specifications	6
Order code	7
Dimensions	8
Connector M12, axial	8
Connector M12, radial	9
Position magnets	10
Output specification	17
Analog output	17
Analog output, redundant.....	20
Characteristics for magnetic angle sensors	22
Accessories	23
Connector cable M12, 4 pin	23
Connector cable M12, 8 pin	24

Analog output



Sensor features

- Measurement range 0 ... 360°
- Protection class IP67/IP69
- Analog output
- Non-contact with external position magnet, no wear
- Housing: Stainless steel 1.4404
- Application: hygienic areas

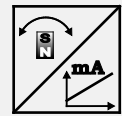
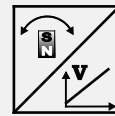

Specifications

Output	Voltage 0.5 ... 10 V Voltage 0.5 ... 4.5 V Current 4 ... 20 mA, 3 wire
Measurement range	0 ... 15° to 0 ... 360° (in 15° increments)
Resolution	0.03% (60 ... 360°); 0.1% (15 ... 45°)
Repeatability	±0.03% (60 ... 360°); ±0.1% (15 ... 45°)
Linearity	±0.3% f.s. (typical)
Rated distance sensor / magnet	Depending on the position magnet
Protection class	IP67/IP69 (connector output with IP67/IP69 connector cable)
Housing material	Stainless steel 1.4404
Mounting	Screws M6
Connection	5-pin connector M12 (compatible to 4-pin connector)
Temperature range	-40 ... +85°C
Shock	DIN EN 60068-2-27:2010, 100 g/11 ms, 100 shocks
Vibration	DIN EN 60068-2-6:2008, 20 g 10 Hz-2 kHz, 10 cycles
Weight	390 g approx.
EMC	DIN EN 61326-1:2013

Order code

PRAS7 - 1 - 2 - 3 - 4 - 5 - 6

1 Mechanical connection

K = Non-contact with external position magnet

2 Measurement range (0 ... 15° to 0 ... 360°, in 15° increments)

15 / 30 / 45 / ... / 345 / 360

3 Output

U2 = Voltage 0.5 ... 10 V (excitation voltage 18 ... 36 V DC)
U2B = Voltage 0.5 ... 10 V (excitation voltage 11.5 ... 27 V DC)
U6 = Voltage 0.5 ... 4.5 V ratiometric (excitation voltage 5 V DC)
U8 = Voltage 0.5 ... 4.5 V (excitation voltage 11 ... 36 V DC)
I1 = Current 4 ... 20 mA, 3 wire (excitation voltage 18 ... 36 V DC)
I1B = Current 4 ... 20 mA, 3 wire (excitation voltage 10 ... 27 V DC)

4 Signal characteristics

CW = Signal increasing CW, clockwise
CCW = Signal increasing CCW, counterclockwise

5 Connection

M12A5 = 5-pin connector M12 axial (compatible with 4-pin connector)
M12R5 = 5-pin connector M12 radial (compatible with 4-pin connector)

6 Housing material

VA = Stainless steel 1.4404

Order example

PRAS7 - K - 360 - I1 - CW - M12A5 - VA

Accessories:

Connector cable (see page 23)

Position magnets (see from page 10)

Analog output, redundant



Sensor features

- Measurement range 0 ... 360°
- Protection class IP67/IP69
- Analog output, redundant
- Non-contact with external position magnet, no wear
- Housing: Stainless steel 1.4404
- Application: hygienic areas

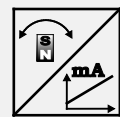
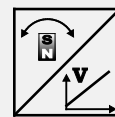

Specifications

Output	Voltage 0.5 ... 10 V, redundant Voltage 0.5 ... 4.5 V, redundant Current 4 ... 20 mA, 3 wire, redundant
Measurement range	0 ... 15° to 0 ... 360° (in 15° increments)
Resolution	0.03% (60 ... 360°); 0.1% (15 ... 45°)
Repeatability	±0.03% (60 ... 360°); ±0.1% (15 ... 45°)
Linearity	±0.3% f.s. (typical)
Rated distance sensor / magnet	Depending on the position magnet
Protection class	IP67/IP69 (connector output with IP67/IP69 connector cable)
Housing material	Stainless steel 1.4404
Mounting	Screws M6
Connection	8-pin connector M12
Temperature range	-40 ... +85°C
Shock	DIN EN 60068-2-27:2010, 100 g/11 ms, 100 shocks
Vibration	DIN EN 60068-2-6:2008, 20 g 10 Hz-2 kHz, 10 cycles
Weight	390 g approx.
EMC	DIN EN 61326-1:2013

Order code

PRAS7 - 1 - 2 - 3 - 4 - 5 - 6

1 Mechanical connection

K = Non-contact with external position magnet

2 Measurement range (0 ... 15° to 0 ... 360°, in 15° increments)

15 / 30 / 45 / ... / 345 / 360

3 Output

U2R = Voltage 0.5 ... 10 V, redundant (excitation voltage 18 ... 36 V DC)
U6R = Voltage 0.5 ... 4.5 V ratiometric, redundant (excitation voltage 5 V DC)
U8R = Voltage 0.5 ... 4.5 V, redundant (excitation voltage 11 ... 36 V DC)
I1R = Current 4... 20 mA, 3 wire, redundant (excitation voltage 18 ... 36 V DC)
(output I1R possible only with CW/CCW signal characteristics)

4 Signal characteristics

CW/CCW = Signal 1 increasing clockwise, signal 2 increasing counterclockwise
CW/CW* = Signal 1 and signal 2 increasing clockwise
CCW/CCW* = Signal 1 and signal 2 increasing counterclockwise

* not available with output I1R

5 Connection

M12A8 = 8-pin connector M12 axial
M12R8 = 8-pin connector M12 radial

6 Housing material

VA = Stainless steel 1.4404

Order example

PRAS7 - K - 360 - U2R - CW/CCW - M12R8 - VA

Accessories:

Connector cable (see page 24)

Position magnets (see from page 10)

Dimensions

Connector M12, axial

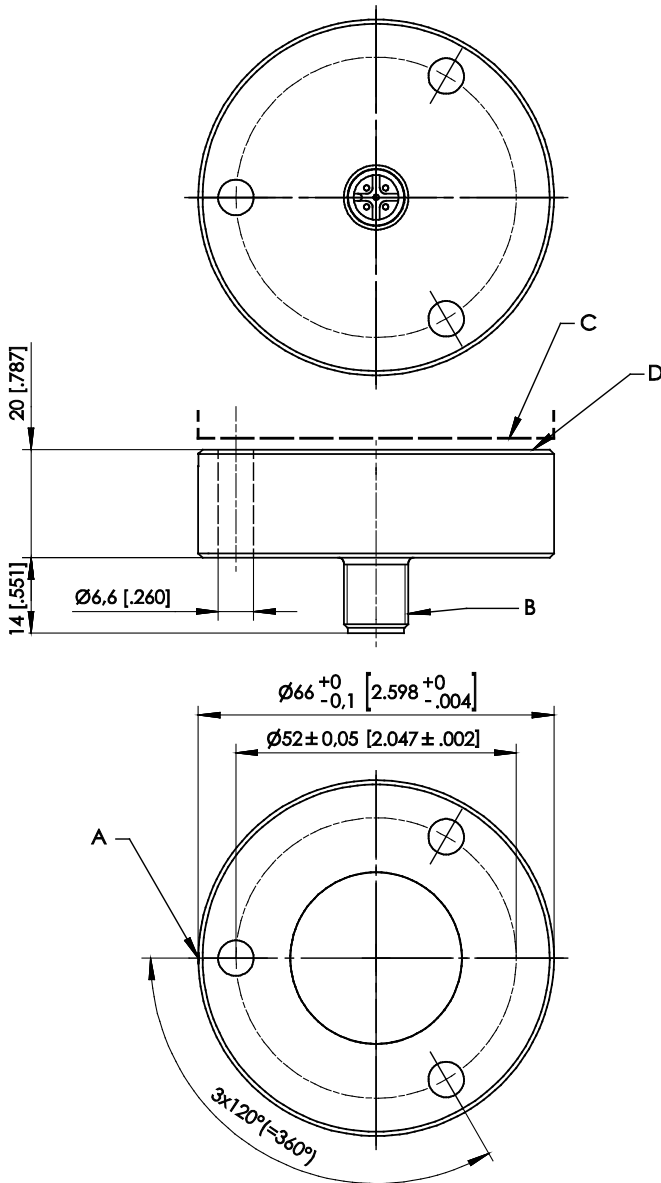

- A – Position magnet
- B – Marking
- C – Measurement area
- D – Connector M12

Dimensions in mm [inch].
Dimensions informative only.
For guaranteed dimensions consult factory.

Connector M12, radial

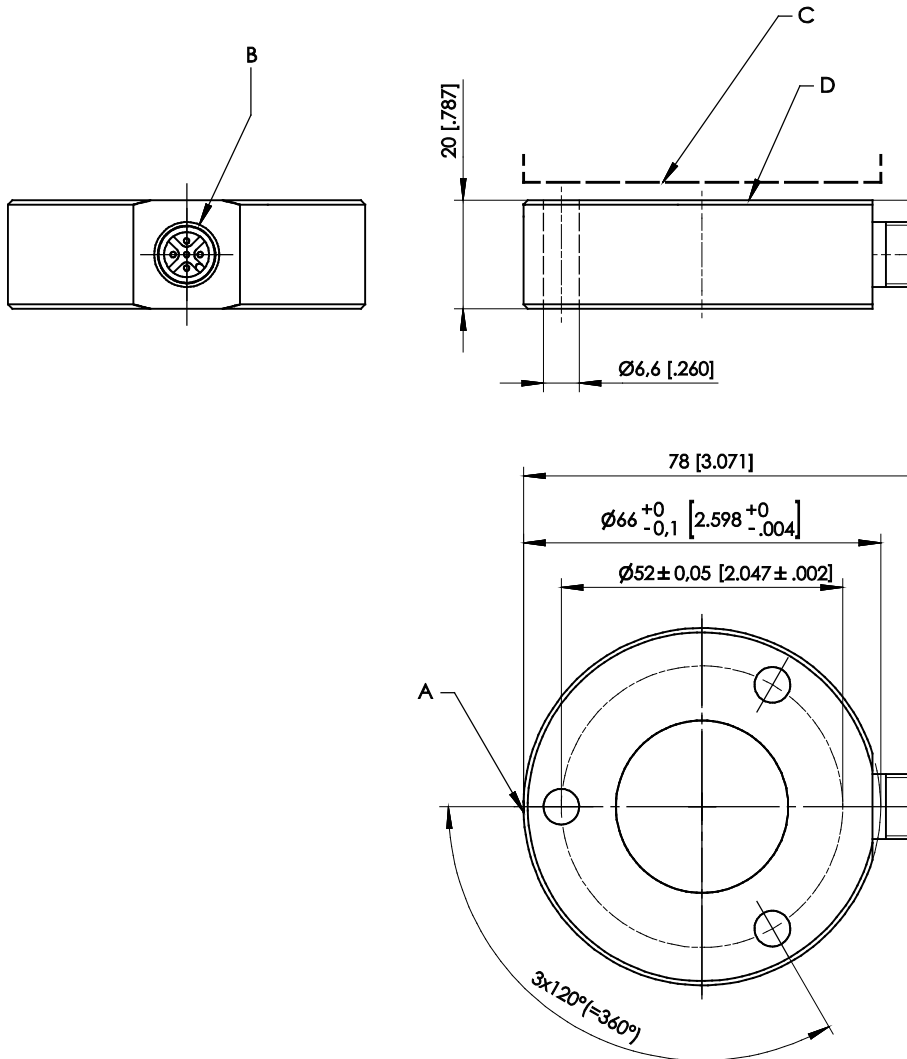

- A – Position magnet
- B – Marking
- C – Measurement area
- D – Connector M12

Dimensions in mm [inch].
Dimensions informative only.
For guaranteed dimensions consult factory.

Position magnets

PRMAG20

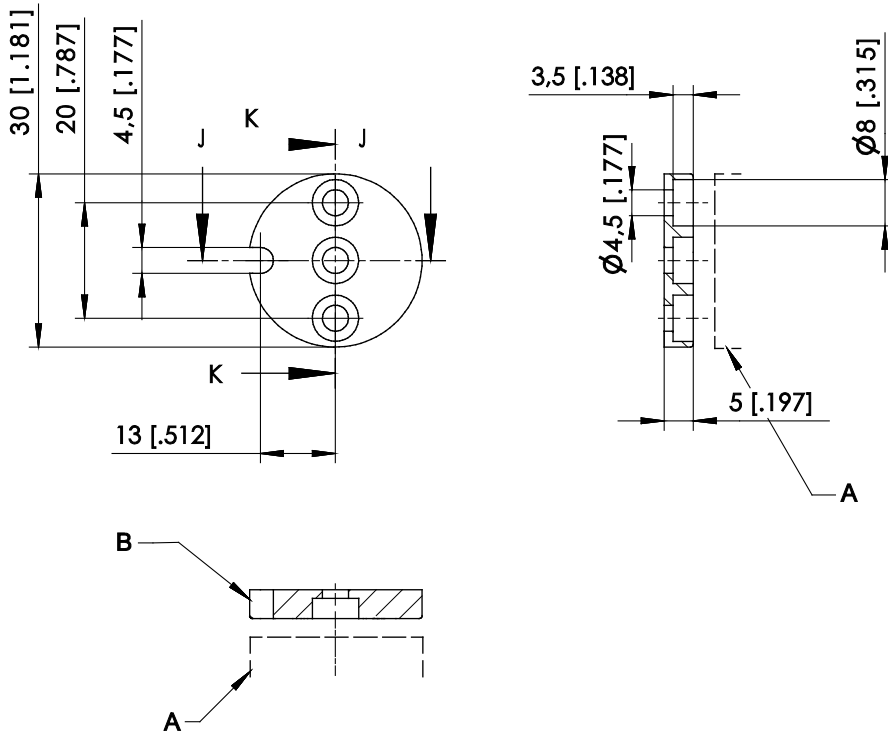

A – Sensor
B – Marking

Order code	Weight	Material	Moment of inertia
PRMAG20	approx. 12 g	zinc coated steel, plastic	1.3 kgmm ²

A misalignment of the position magnet has an effect on the linearity.

Dimensions in mm [inch].

Dimensions informative only.

For guaranteed dimensions please consult factory.

PRMAG21

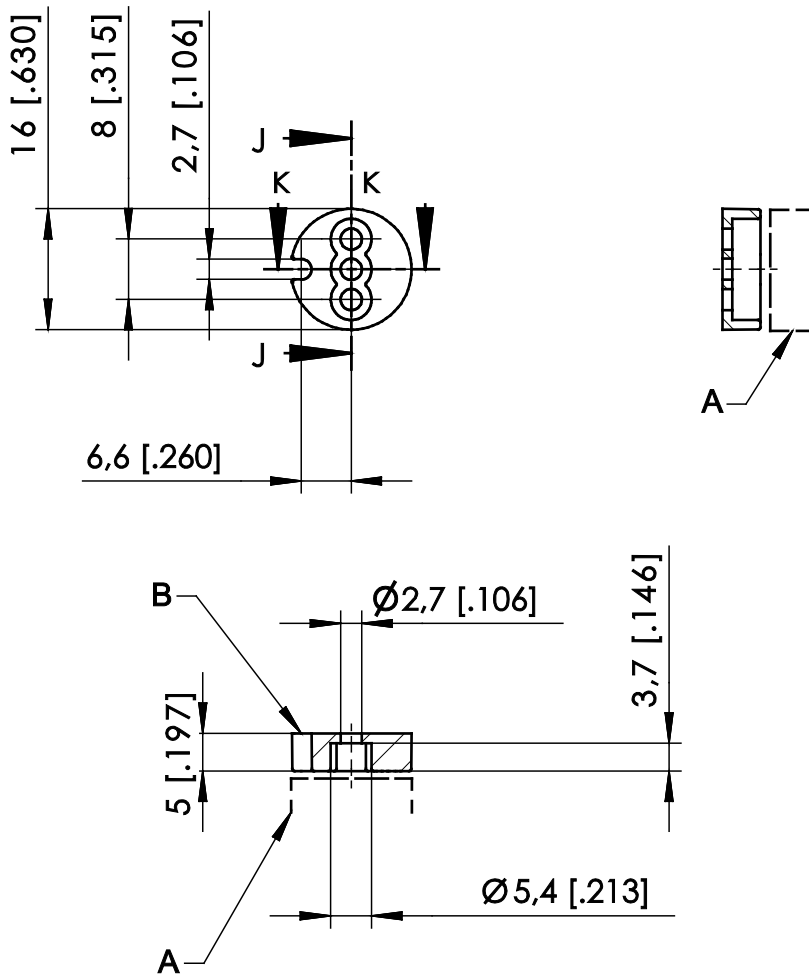

A – Sensor
B – Marking

Order code	Weight	Material	Moment of inertia
PRMAG21	approx. 3 g	zinc coated steel; plastic	0.1 kgmm ²

A misalignment of the position magnet has an effect on the linearity.

Dimensions in mm [inch]
Dimensions informative only.
For guaranteed dimensions please consult factory.

PRMAG22

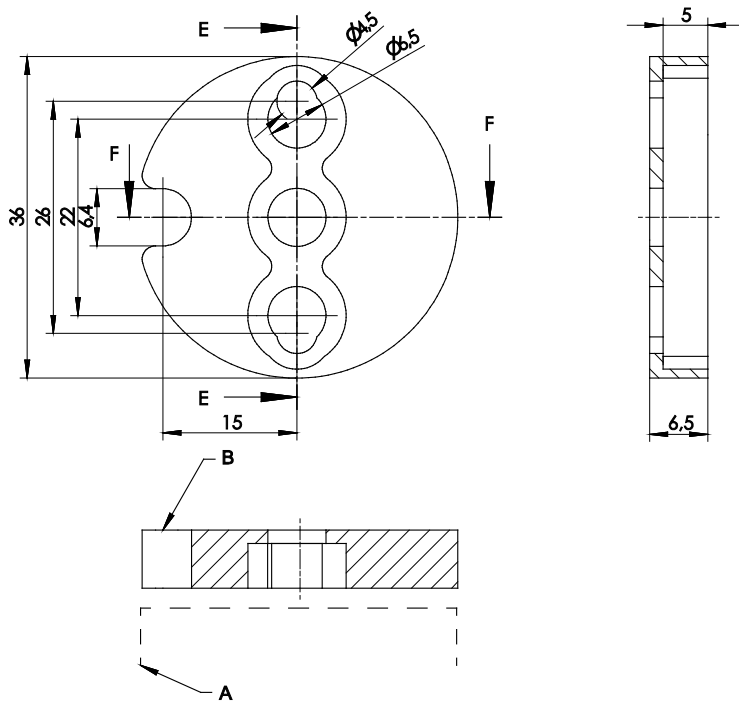

A – Sensor
B – Marking

Order code	Weight	Material	Moment of inertia
PRMAG22	approx. 19 g	zinc coated steel, plastic	3 kgmm ²

A misalignment of the position magnet has an effect on the linearity.

Dimensions in mm [inch].
Dimensions informative only
For guaranteed dimensions please consult factory.

PRMAG2-Z / PRMAG2-Z-VA

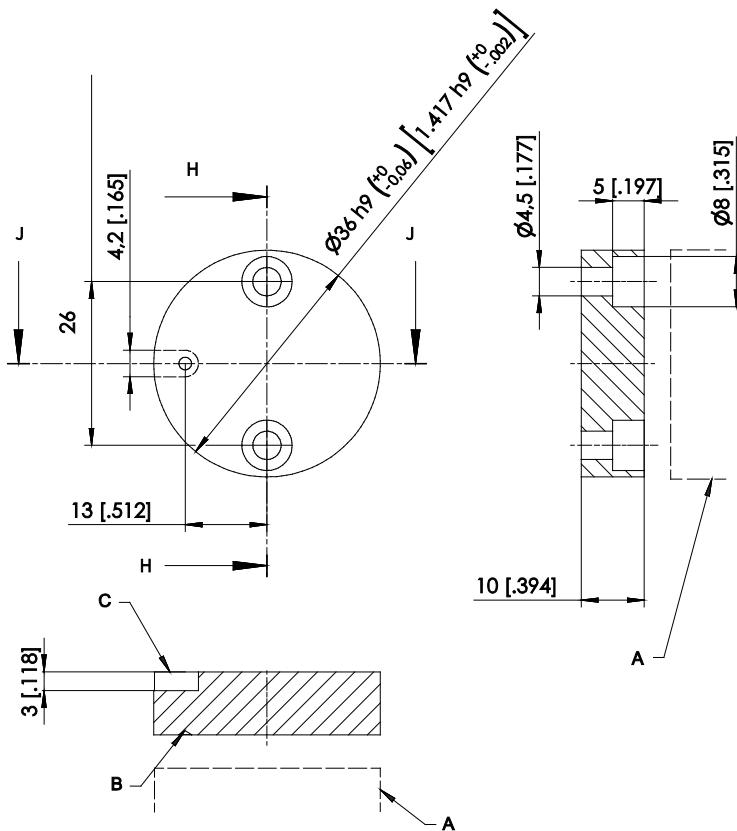

- A – Sensor
- B – Marking
- C – Notch

Order code	Weight	Material	Moment of inertia
PRMAG2-Z	approx. 30 g	AlMgSi1	4.9 kgmm ²
PRMAG2-Z-VA	approx. 67 g	stainless steel 1.4404	10.9 kgmm ²

A misalignment of the position magnet has an effect on the linearity.

Dimensions in mm [inch].

Dimensions informative only.

For guaranteed dimensions please consult factory.

PRMAG5-Z / PRMAG5-Z-VA

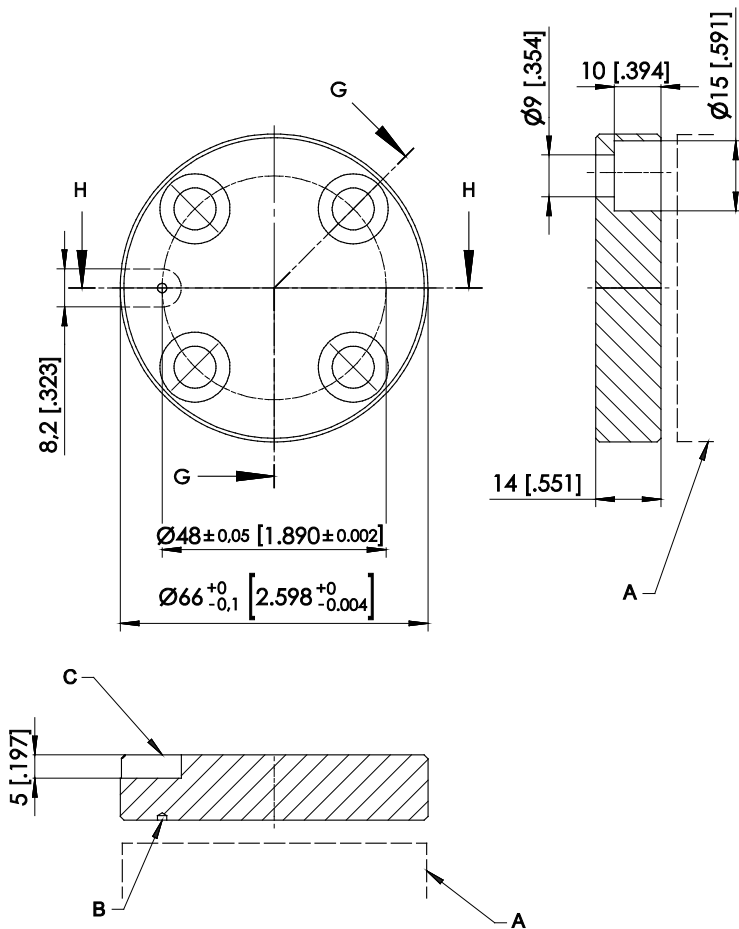

A – Sensor
B – Marking
C – Notch

Order code	Weight	Material	Moment of inertia
PRMAG5-Z	approx. 110 g	AlMgSi1	59,9 kgmm ²
PRMAG5-Z-VA	approx. 275 g	stainless steel 1.4404	149,9 kgmm ²

A misalignment of the position magnet has an effect on the linearity.

Dimensions in mm [inch].

Dimensions informative only.

For guaranteed dimensions please consult factory.

PRMAG6-Z / PRMAG6-Z-VA

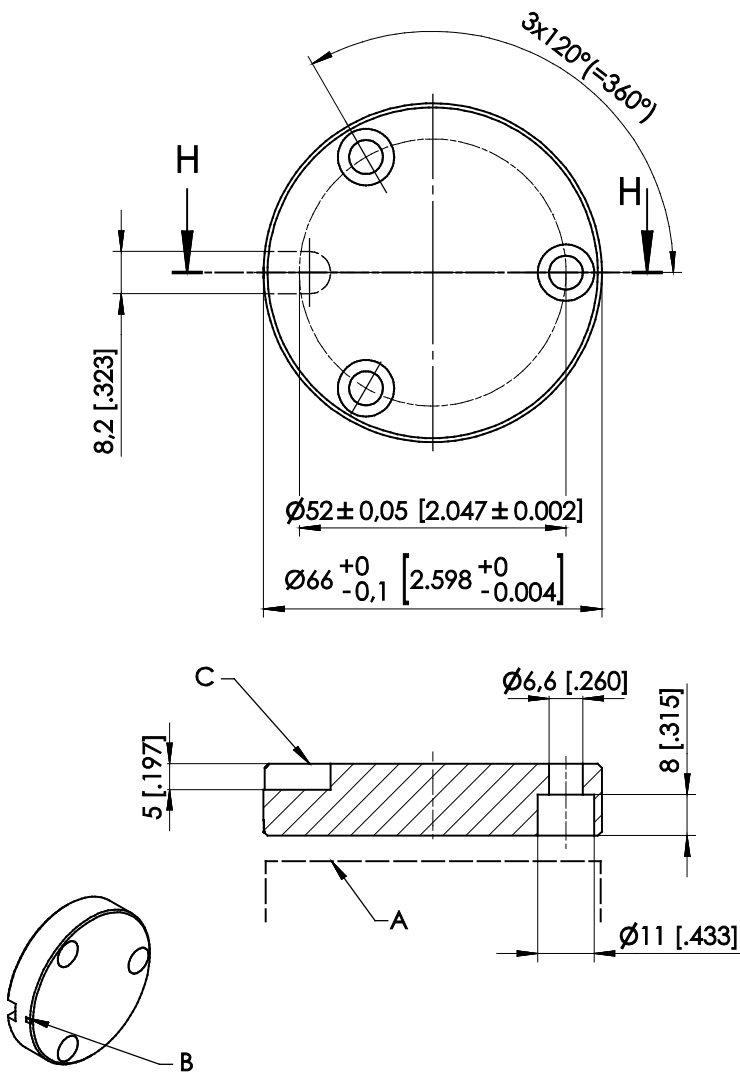

A – Sensor
B – Marking
C – Notch

Order code	Weight	Material	Moment of inertia
PRMAG6-Z	approx. 110 g	AlMgSi1,	65 kgmm ²
PRMAG6-Z-VA	approx. 315 g	stainless steel 1.4404	190 kgmm ²

A misalignment of the position magnet has an effect on the linearity.

Dimensions in mm [inch].

Dimensions informative only.

For guaranteed dimensions please consult factory.

PRMAG7-Z-VA

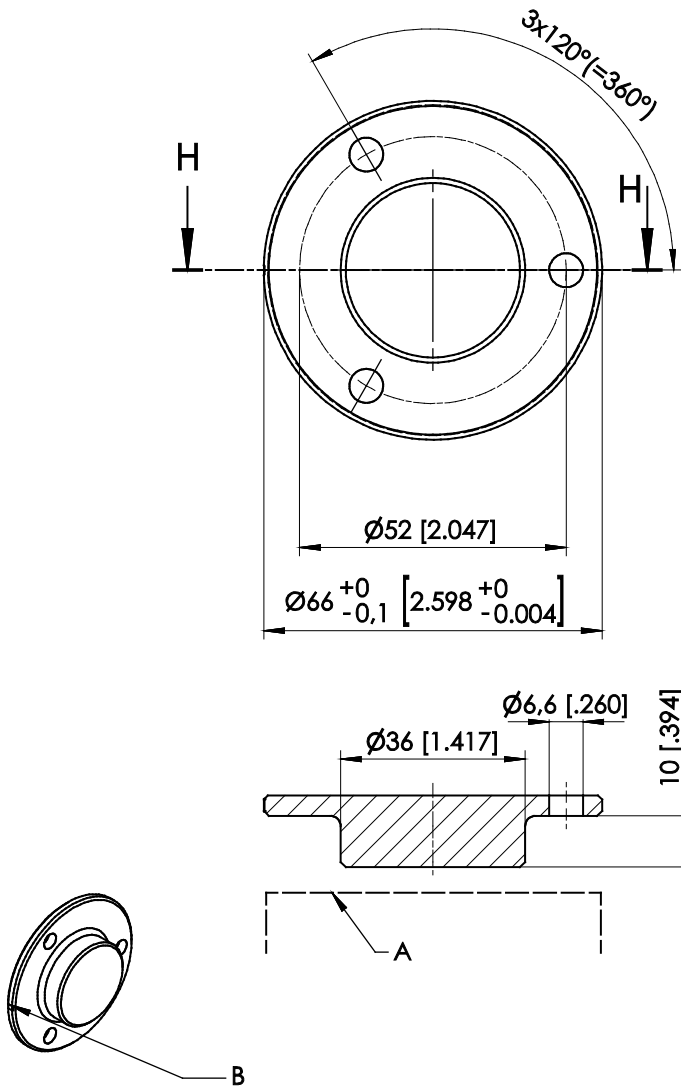

A – Sensor
B – Marking

Order code	Weight	Material	Moment of inertia
PRMAG7-Z-VA	approx. 146 g	stainless steel 1.4404	68 kgmm ²

A misalignment of the position magnet has an effect on the linearity.

Dimensions in mm [inch]

Dimensions informative only.

For guaranteed dimensions please consult factory.

Output specification

Analog output

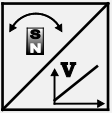
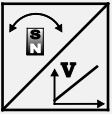
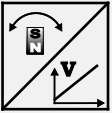
U2 Voltage output 0.5 ... 10 V 	Excitation voltage	18 ... 36 V DC
	Excitation current	typical 10 mA max. 15 mA
	Output voltage	0.5 ... 10 V DC
	Output current	2 mA max.
	Measuring rate	1 kHz standard
	Stability (temperature)	$\pm 50 \times 10^{-6} / ^\circ\text{C}$ f.s. (typical for $90^\circ \dots 360^\circ$) $\pm 100 \times 10^{-6} / ^\circ\text{C}$ f.s. (typical for $<90^\circ$)
	Protection	Reverse polarity, short circuit
	Operating temperature	-40 ... +85 °C
	EMC	DIN EN 61326-1:2013
U2B Voltage output 0.5 ... 10 V 	Excitation voltage	11.5 ... 27 V DC
	Excitation current	typical 12 mA max. 16 mA
	Output voltage	0,5 ... 10 V DC
	Output current	2 mA max.
	Measuring rate	1 kHz standard
	Stability (temperature)	$\pm 50 \times 10^{-6} / ^\circ\text{C}$ f.s. (typical for $90^\circ \dots 360^\circ$) $\pm 100 \times 10^{-6} / ^\circ\text{C}$ f.s. (typical for $<90^\circ$)
	Protection	Reverse polarity, short circuit
	Operating temperature	-40 ... +85 °C
	EMC	DIN EN 61326-1:2013
U6 Voltage output 10 ... 90 % ratiometric 	Excitation voltage	5 V DC $\pm 10\%$
	Excitation current	typical 8 mA max. 12 mA
	Output voltage	10 ... 90 % of the excitation voltage
	Output current	2 mA max.
	Measuring rate	1 kHz standard
	Stability (temperature)	$\pm 50 \times 10^{-6} / ^\circ\text{C}$ f.s. (typical for $90^\circ \dots 360^\circ$) $\pm 100 \times 10^{-6} / ^\circ\text{C}$ f.s. (typical for $<90^\circ$)
	Protection	Reverse polarity, short circuit
	Operating temperature	-40 ... +85 °C
	EMC	DIN EN 61326-1:2013

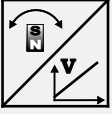
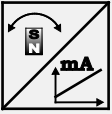
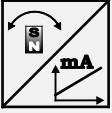
U8 Voltage output 0.5 ... 4.5 V 	Excitation voltage	11 ... 36 V DC
	Excitation current	typical 10 mA max. 20 mA
	Output voltage	0.5 ... 4.5 V DC
	Output current	2 mA max.
	Measuring rate	1 kHz standard
	Stability (temperature)	$\pm 50 \times 10^{-6} / ^\circ\text{C}$ f.s. (typical for $90^\circ \dots 360^\circ$) $\pm 100 \times 10^{-6} / ^\circ\text{C}$ f.s. (typical for $<90^\circ$)
	Protection	Reverse polarity, short circuit
	Operating temperature	-40 ... +85 °C
	EMC	DIN EN 61326-1:2013
I1 Current output 4 ... 20 mA, 3 wires 	Excitation voltage	18 ... 36 V DC
	Excitation current	typical 30 mA max. 35 mA
	Load R_L	500 Ω max.
	Output current	4 ... 20 mA
	Measuring rate	1 kHz standard
	Stability (temperature)	$\pm 50 \times 10^{-6} / ^\circ\text{C}$ f.s. (typical for $90^\circ \dots 360^\circ$) $\pm 100 \times 10^{-6} / ^\circ\text{C}$ f.s. (typical for $<90^\circ$)
	Protection	Reverse polarity, short circuit
	Operating temperature	-40 ... +85 °C
	EMC	DIN EN 61326-1:2013
I1B Current output 4 ... 20 mA, 3 wires 	Excitation voltage	10 ... 27 V DC
	Excitation current	typical 32 mA max. 36 mA
	Load R_L	250 Ω max.
	Output current	4 ... 20 mA
	Measuring rate	1 kHz standard
	Stability (temperature)	$\pm 50 \times 10^{-6} / ^\circ\text{C}$ f.s. (typical for $90^\circ \dots 360^\circ$) $\pm 100 \times 10^{-6} / ^\circ\text{C}$ f.s. (typical for $<90^\circ$)
	Protection	Reverse polarity, short circuit
	Operating temperature	-40 ... +85 °C
	EMC	DIN EN 61326-1:2013

Signal diagram

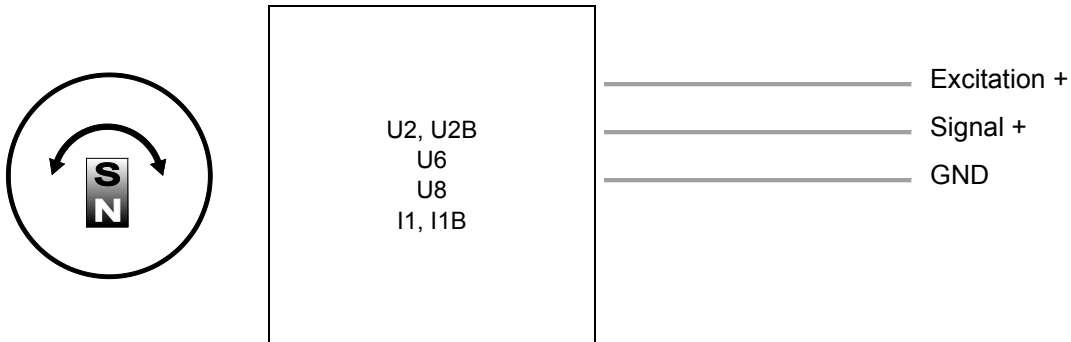

**Signal wiring
(connector and cable output)**

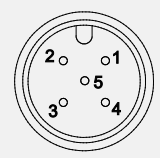
Signal	Connector pin no.	Cable color	View to the sensor connector
Excitation +	1	brown	
Signal	2	white	
GND	3	blue	
Do not connect!	4	black	
Do not connect!	5	grey	

3-wire current 4...20 mA interface: GND has to be connected!

Analog output, redundant

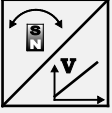
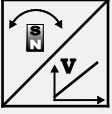
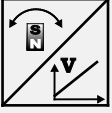
U2R Voltage output 0.5 ... 10 V 	Excitation voltage	18 ... 36 V DC
	Excitation current	typical 10 mA max. 15 mA per channel
	Output voltage	0.5 ... 10 V DC
	Output current	2 mA max.
	Measuring rate	1 kHz Standard
	Stability (temperature)	$\pm 50 \times 10^{-6} / ^\circ\text{C}$ f.s. (typical for $90^\circ \dots 360^\circ$) $\pm 100 \times 10^{-6} / ^\circ\text{C}$ f.s. (typical for $<90^\circ$)
	Protection	Reverse polarity, short circuit
	Operating temperature	-40 ... +85 °C
	EMC	DIN EN 61326-1:2013
	U6R Voltage output 10 ... 90 % ratiometric 	Excitation voltage
Excitation current		typical 8 mA max. 12 mA per channel
Output voltage		10 ... 90 % of the excitation voltage
Output current		2 mA max.
Measuring rate		1 kHz standard
Stability (temperature)		$\pm 50 \times 10^{-6} / ^\circ\text{C}$ f.s. (typical for $90^\circ \dots 360^\circ$) $\pm 100 \times 10^{-6} / ^\circ\text{C}$ f.s. (typical for $<90^\circ$)
Protection		Reverse polarity, short circuit
Operating temperature		-40 ... +85 °C
EMC		EN 61326-1:2013
U8R Voltage output 0.5 ... 4.5 V 		Excitation voltage
	Excitation current	typical 10 mA max. 20 mA per channel
	Output voltage	0.5 ... 4,5 V DC
	Output current	2 mA max.
	Measuring rate	1 kHz standard
	Stability (temperature)	$\pm 50 \times 10^{-6} / ^\circ\text{C}$ f.s. (typical for $90^\circ \dots 360^\circ$) $\pm 100 \times 10^{-6} / ^\circ\text{C}$ f.s. (typical for $<90^\circ$)
	Protection	Reverse polarity, short circuit
	Operating temperature	-40 ... +85 °C
	EMC	DIN EN 61326-1:2013

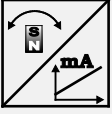
I1R Current output 4 ... 20 mA, 3 wires 	Excitation voltage	18 ... 36 V DC
	Excitation current	typical 30 mA max. 35 mA per channel
	Load R _L	500 Ω max.
	Output current	4 ... 20 mA
	Measuring rate	1 kHz standard
	Stability (temperature)	±50 x 10 ⁻⁶ / °C f.s. (typical for 90° ... 360°) ±100 x 10 ⁻⁶ / °C f.s. (typical for <90°)
	Protection	Reverse polarity, short circuit
	Operating temperature	-40 ... +85 °C
	EMC	DIN EN 61326-1:2013

Signal wiring

2 channels, redundant (connector and cable output)

Channel	Signal	Connector pin no.	Cable color	View to the sensor connector
1	Excitation +	1	white	
1	Signal	2	brown	
1	GND	3	green	
1	Do not connect!	4	yellow	
2	Excitation +	5	grey	
2	Signal	6	pink	
2	GND	7	blue	
2	Do not connect!	8	red	

Characteristics for magnetic angle sensors

Output signal CW
(clockwise increasing)

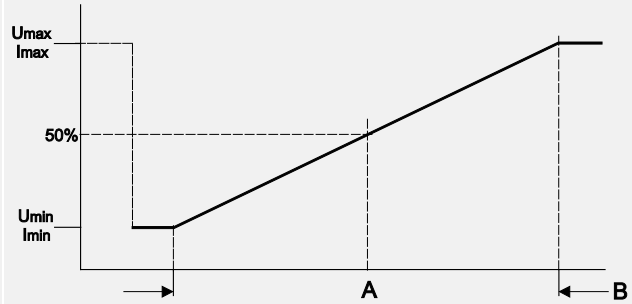

Output signal CCW
(counterclockwise increasing)

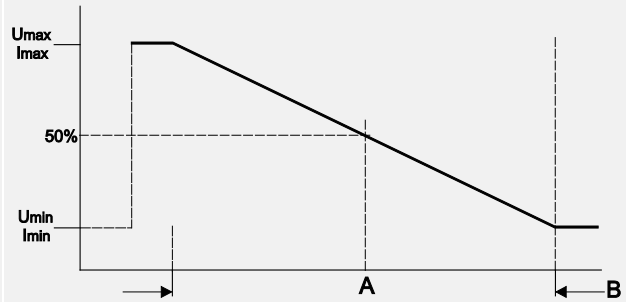

Example angular range 90°

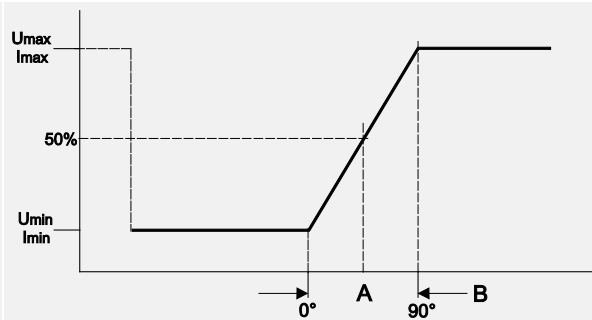

Example angular range 360°

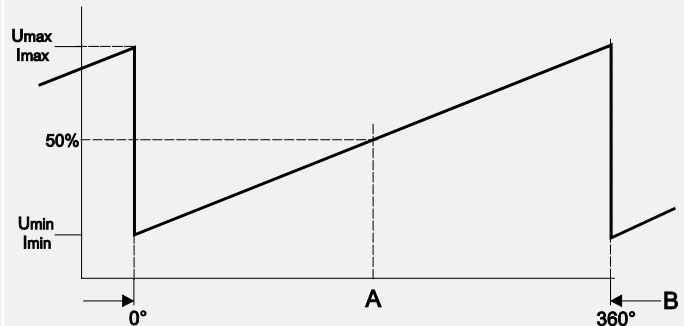

A – Marking
B – Measurement range [°]

Accessories

Connector cable M12, 4 pin (angular coupling)

shielded connector

Suitable for 5-pin
sensor connectors

The 4-core screened cable is supplied with a mating 4-pin 90° M12 connector at one end and 4 wires at the other end. Available lengths are 2 m, 5 m and 10 m. Wire: cross sectional area 0.34 mm²
Cable diameter: 5.6 ±0.2 mm

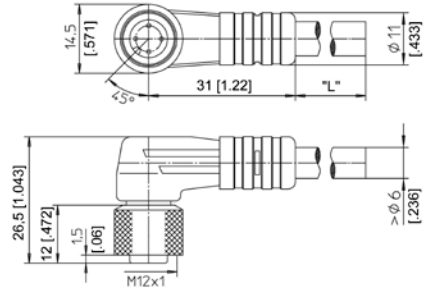

Order code

KAB - xM - M12/4F/W - LITZE

IP69: **KAB - xM - M12/4F/W/69K - LITZE**

xM = length in m

Connector cable M12, 4 pin (straight coupling)

shielded connector

Suitable for 5-pin
sensor connectors

The 4-core screened cable is supplied with a mating 4-pin M12 connector at one end and 4 wires at the other end. Available lengths are 2 m, 5 m and 10 m. Wire: cross sectional area 0.34 mm²
Cable diameter: 5.6 ±0.2 mm

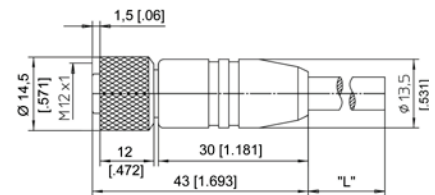

Order code

KAB - xM - M12/4F/G - LITZE

IP69: **KAB - xM - M12/4F/G/69K - LITZE**

xM = length in m

Signal wiring	Plug connection / cable color			
	M12, 4 pin	1	2	3
	brown	white	blue	black

Applicable for cable carriers

Maximum movement speed	3 m/s
Maximum acceleration	5 m/s ²
Minimum bending radius	10 x cable diameter

**Connector cable M12, 8 pin
(angular coupling)**

shielded connector

The 8-lead shielded cable is supplied with a mating 8-pin 90° M12 connector at one end and 8 wires at the other end. Available lengths are 2 m, 5 m and 10 m. Wire: cross sectional area 0.25 mm² Cable diameter: 6.3 ±0.2 mm

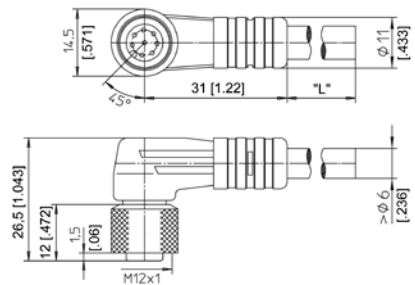

Order code

KAB - xM - M12/8F/W - LITZE

IP69: **KAB - xM - M12/8F/W/69K - LITZE**

xM = length in m

**Connector cable M12, 8 pin
(straight coupling)**

shielded connector

The 8-lead shielded cable is supplied with a mating 8-pin M12 connector at one end and 8 wires at the other end. Available lengths are 2 m, 5 m and 10 m. Wire: cross sectional area 0.25 mm² Cable diameter: 6.3 ±0.2 mm

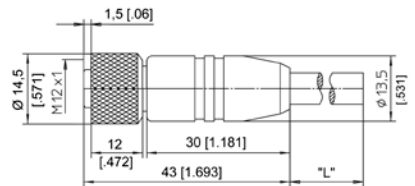

Order code

KAB - xM - M12/8F/G - LITZE

IP69: **KAB - xM - M12/8F/G/69K - LITZE**

xM = length in m

Signal wiring M12, 8 pin	Plug connection / cable color							
	1	2	3	4	5	6	7	8
	white	brown	green	yellow	grey	pink	blue	red

Applicable for cable carriers

Maximum movement speed	3 m/s
Maximum acceleration	5 m/s ²
Minimum bending radius	10 x cable diameter

POSIROT[®]

Magnetic Angle Encoders

PRDS7
Magnetic Angle Encoder

Datasheet



Copyright

© ASM GmbH
Am Bleichbach 18-24
85452 Moosinning
Germany

The information presented in this data sheet does not form part of any quotation or contract, is believed to be accurate and reliable and may be changed without notice. No liability will be accepted by ASM for any consequence of its use. Publication thereof does not convey nor imply any license under patent or industrial or intellectual property rights. Applications that are described herein for any of these products are for illustrative purpose only.

ASM makes no representation or warranty that such applications will be suitable for the specified use without further testing or modification.

Incremental output	4
Specifications	4
Order code	5
Digital output SSI	6
Specifications	6
Order code	7
Digital output CAN	8
Specifications	8
Order code	9
Dimensions	10
Connector M12, axial.....	10
Connector M12, radial	11
Position magnets.....	12
Output specification	19
Incremental output	19
SSI output	23
Digital output CANopen.....	25
Digital output CAN SAE J1939	27
Characteristics for magnetic angle sensors.....	29
Accessories.....	30
Connector cable M12, 8 pin	30
Connector/bus cable M12, 5 pin CAN-Bus	31
T-connector for bus cable M12, 5 pin CAN-Bus	31
Terminating resistor M12, 5 pin CAN-Bus	31

Incremental output



Sensor features

- Measurement range 0 ... 360°
- Protection class IP67/IP69
- Incremental output
- Non-contact with external position magnet
- Housing: Stainless steel 1.4404
- Application: hygienic areas

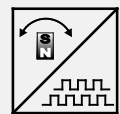

Specifications

Output	Incremental encoder output RS422-/HTL compatible, filtered output
Measurement range	0 ... 360°
Resolution (pulses per revolution)	25 / 50 / 100 / 200 / 256 / 300 / 400 / 500 / 512 / 1000 / 1024
Linearity	±1% (typical)
Rated distance sensor / magnet	Depending on the position magnet
Protection class	IP67/IP69 (connector output with IP67/IP69 connector cable)
Material	Stainless steel 1.4404
Mounting	Screws M6
Connection	8-pin connector M12
Temperature range	-40 ... +85°C
Shock	DIN EN 60068-2-27:2010, 100 g/11 ms, 100 shocks
Vibration	DIN EN 60068-2-6:2008, 20 g 10 Hz-2 kHz, 10 cycles
Weight	390 g approx.
EMC	DIN EN 61326-1:2013

Order code

PRDS7 - 1 - 2 - 3 - 4 - 5

1 Mechanical connection

K = Non-contact with external position magnet

2 Resolution

25 / 50 / 100 / 200 / 256 / 300 / 400 / 500 / 512 / 1000 / 1024

3 Output

RS5VF = RS422 compatible output with excitation 5 V DC, filtered output
RS24VF = RS422 compatible output with excitation 10 ... 36 V, filtered output
HT24VF = HTL compatible output with excitation 18 ... 36 V, filtered output

4 Connection

M12A8 = 8-pin connector M12, axial
M12R8 = 8-pin connector M12, radial

5 Housing material

VA = Stainless steel 1.4404

Order example

PRDS7 - K - 1024 - RS24VF - M12A8 - VA

Accessories:

Connector cable (see page 30)

Position magnets (see from page 12)

Digital output SSI



Sensor features

- Measurement range 0 ... 360°
- Protection class IP67/IP69
- Digital output SSI
- Non-contact with external position magnet
- Housing: Stainless steel 1.4404
- Application: hygienic areas



Specifications

Output	Synchronous serial SSI
Measurement range	0 ... 360°
Resolution	12 Bit (4096 steps) per revolution
Repeatability	±0.1° (typical)
Linearity	±1% (typical)
Rated distance sensor / magnet	Depending on the position magnet
Protection class	IP67/IP69 (connector output with IP67/IP69 connector cable)
Material	Stainless steel 1.4404
Mounting	Screws M6
Connection	8-pin connector M12
Temperature range	-40 ... +85°C
Shock	DIN EN 60068-2-27:2010, 100 g/11 ms, 100 shocks
Vibration	DIN EN 60068-2-6:2008, 20 g 10 Hz-2 kHz, 10 cycles
Weight	390 g approx.
EMC	DIN EN 61326-1:2013

Order code

PRDS7 - 1 - 2 - 3 - 4 - 5

1 Mechanical connection

K = Non-contact with external position magnet

2 Output

RSSI5V = Synchronous serial output with excitation 5 V DC
RSSI24V = Synchronous serial output with excitation 10 ... 36 V

3 Code characteristics

CW = Signal increasing CW, clockwise
CCW = Signal increasing CCW, counterclockwise

4 Connection

M12A8 = 8-pin connector M12, axial
M12R8 = 8-pin connector M12 radial

5 Housing material

VA = Stainless steel 1.4404

Order example

PRDS7 - K - RSSI24V - CW - M12A8 - VA

Accessories:

Connector cable (see page 30)

Position magnets (see from page 12)

Digital output CAN



Sensor features

- Measurement range 0 ... 360°
- Protection class IP67/IP69
- Digital output CAN
- Non-contact with external position magnet
- Housing: Stainless steel 1.4404
- Redundant version available



Specifications

Output	CANopen (CiA 301-V4.02/406-V3.2) CAN SAE J1939
Measurement range	0 ... 360°
Resolution	0.05° max.
Linearity	±1% (typical)
Rated distance sensor / magnet	Depending on the position magnet
Protection class	IP67/IP69 (connector output with IP67/IP69 connector cable)
Material	Stainless steel 1.4404
Mounting	Screws M6
Connection	5-pin connector M12
Temperature range	-40 ... +85°C
Shock	DIN EN 60068-2-27:2010, 100 g/11 ms, 100 shocks
Vibration	DIN EN 60068-2-6:2008, 20 g 10 Hz-2 kHz, 10 cycles
Weight	390 g approx.
EMC	DIN EN 61326-1:2013

Order code

PRDS7 - 1 - 2 - 3 - 4

1 Shaft

K = Non-contact with external position magnet

2 Output

CANOP = CANopen
CANJ1939 = CAN SAE J1939
CANOPR = CANopen, redundant
CANJ1939R = CAN SAE J1939, redundant

3 Connection

M12A5/CAN = 5-pin connector M12 axial
M12R5/CAN = 5-pin connector M12 radial

4 Housing material

VA = Stainless steel 1.4404

Order example

PRDS7 - K - CANOP - M12A5/CAN - VA

Accessories:

Connector cable (see page 31)

Position magnets (see from page 12)

Dimensions

Connector M12, axial

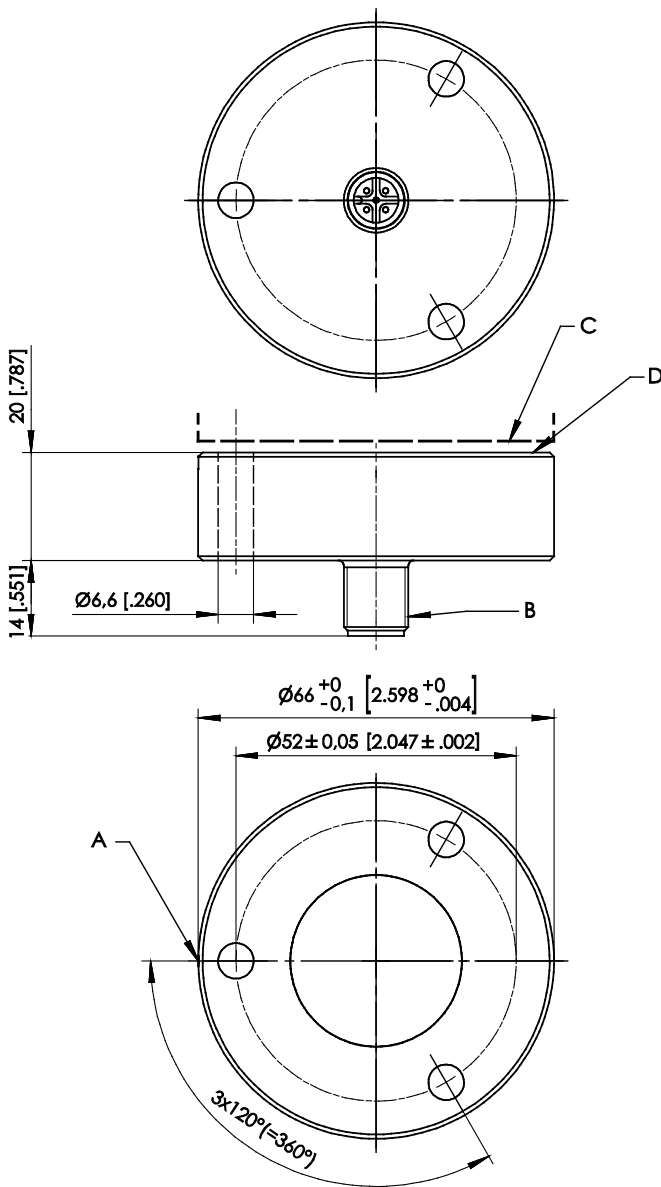

- A – Position magnet
- B – Marking
- C – Measurement area
- D – Connector M12

Dimensions in mm [inch].
Dimensions informative only.
For guaranteed dimensions consult factory.

Connector M12, radial

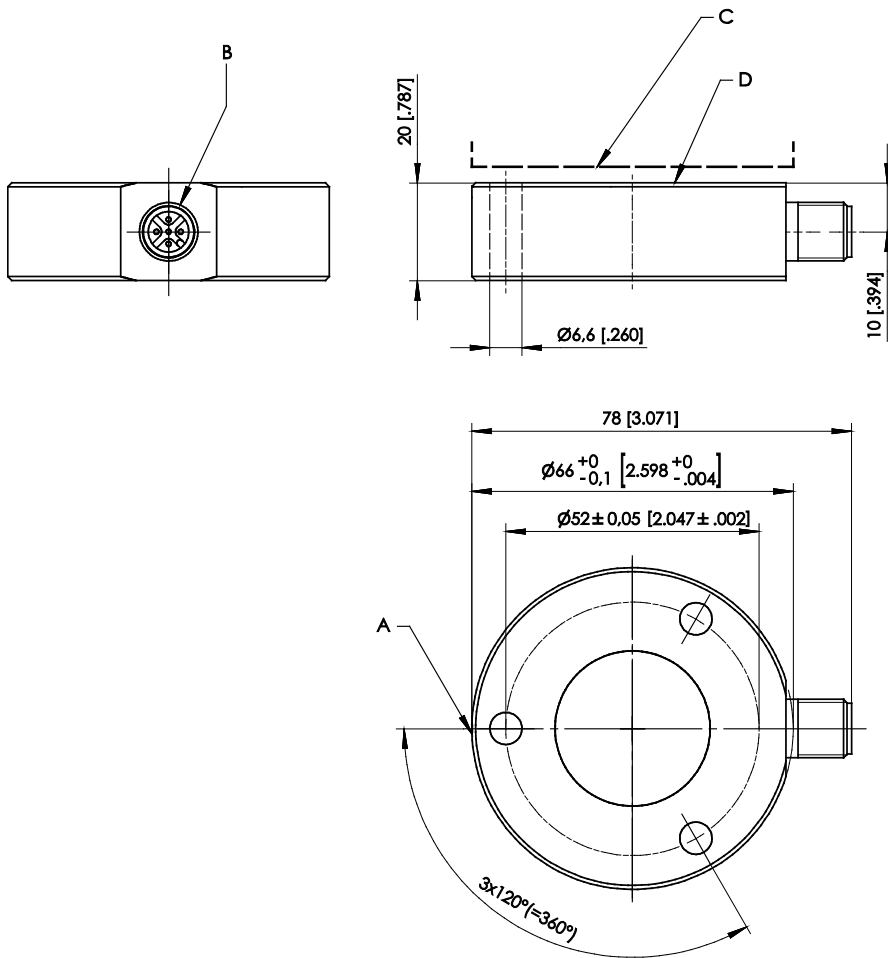

- A – Position magnet
- B – Marking
- C – Measurement area
- D – Connector M12

Dimensions in mm [inch].
Dimensions informative only.
For guaranteed dimensions consult factory.

Position magnets

PRMAG20

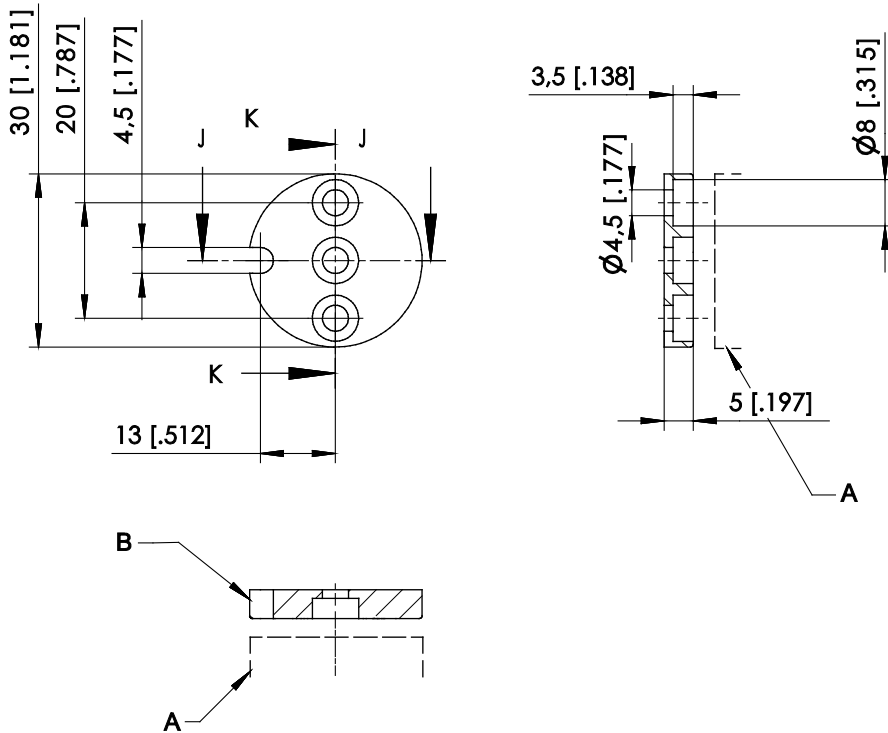

A – Sensor
B – Marking

Order code	Weight	Material	Moment of inertia
PRMAG20	approx. 12 g	zinc coated steel, plastic	1.3 kgmm ²

A misalignment of the position magnet has an effect on the linearity.

Dimensions in mm [inch].

Dimensions informative only.

For guaranteed dimensions please consult factory.

PRMAG21

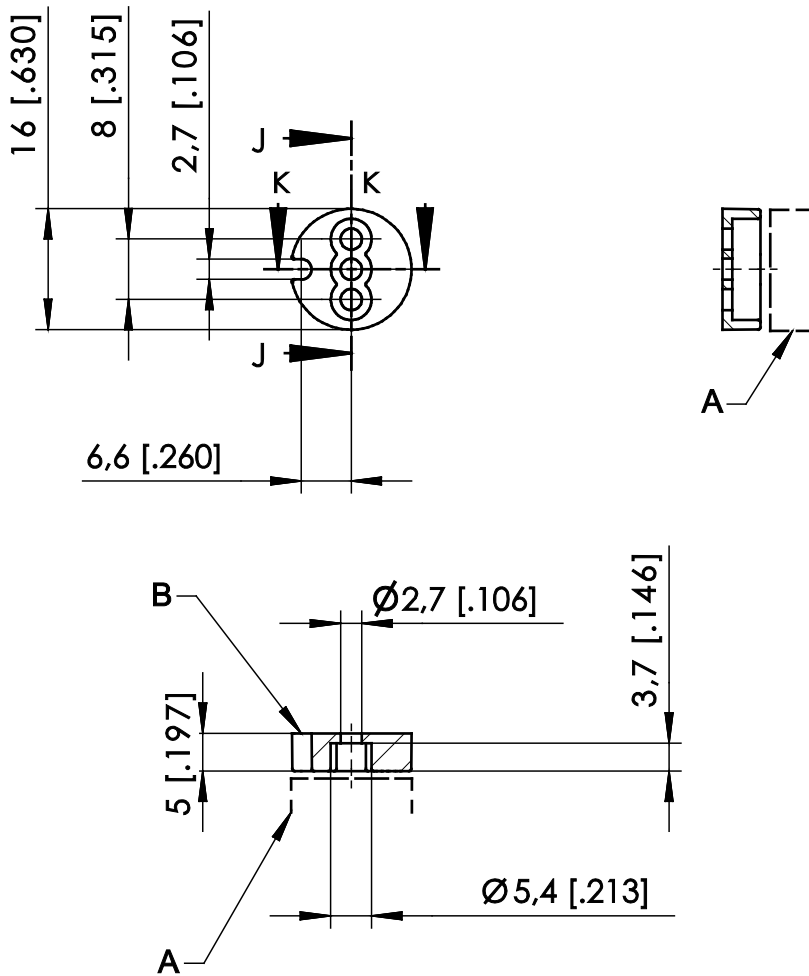

A – Sensor
B – Marking

Order code	Weight	Material	Moment of inertia
PRMAG21	approx. 3 g	zinc coated steel; plastic	0.1 kgmm ²

A misalignment of the position magnet has an effect on the linearity.

Dimensions in mm [inch]

Dimensions informative only.

For guaranteed dimensions please consult factory.

PRMAG22

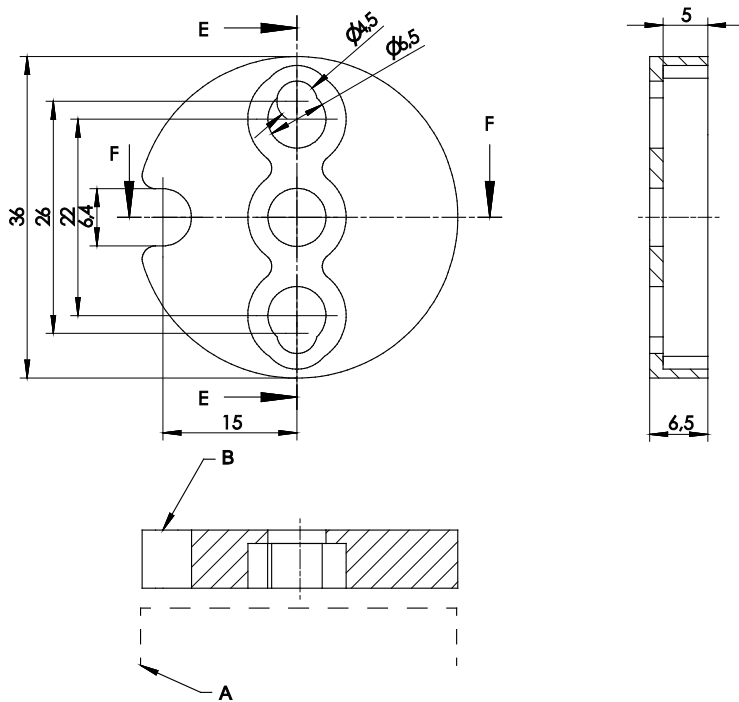

A – Sensor
B – Marking

Order code	Weight	Material	Moment of inertia
PRMAG22	approx. 19 g	zinc coated steel, plastic	3 kgmm ²

A misalignment of the position magnet has an effect on the linearity.

Dimensions in mm [inch].
Dimensions informative only
For guaranteed dimensions please consult factory.

PRMAG2-VA / PRMAG2-Z-VA

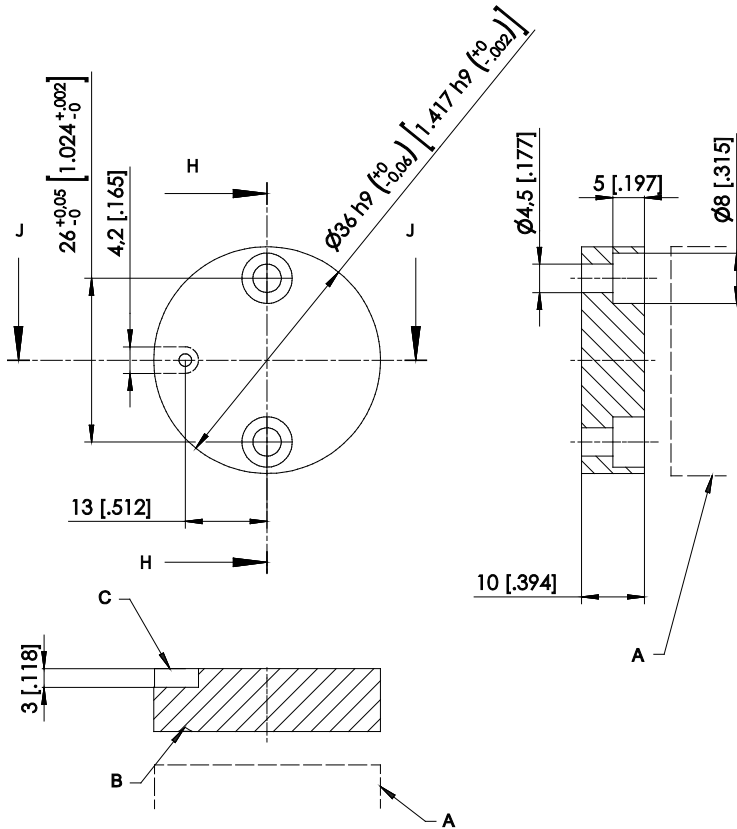

- A – Sensor
- B – Marking
- C – Notch

Order code	Weight	Material	Moment of inertia
PRMAG2-VA	approx. 67 g	stainless steel 1.4404	12 kgmm ²
PRMAG2-Z-VA	approx. 61 g	stainless steel 1.4404	11.5 kgmm ²

A misalignment of the position magnet has an effect on the linearity.

Dimensions in mm [inch].

Dimensions informative only.

For guaranteed dimensions please consult factory.

PRMAG5-Z / PRMAG5-Z-VA

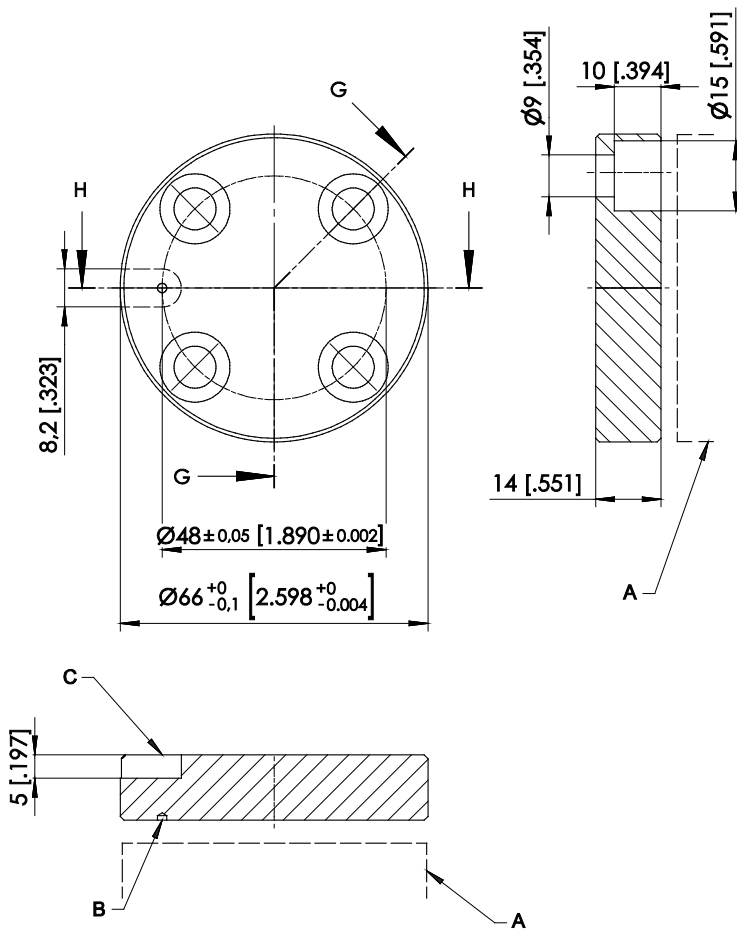

A – Sensor
B – Marking
C – Notch

Order code	Weight	Material	Moment of inertia
PRMAG5-Z	approx. 110 g	AlMgSi1	59,9 kgmm ²
PRMAG5-Z-VA	approx. 275 g	stainless steel 1.4404	149,9 kgmm ²

A misalignment of the position magnet has an effect on the linearity.

Dimensions in mm [inch].

Dimensions informative only.

For guaranteed dimensions please consult factory.

PRMAG6-Z / PRMAG6-Z-VA

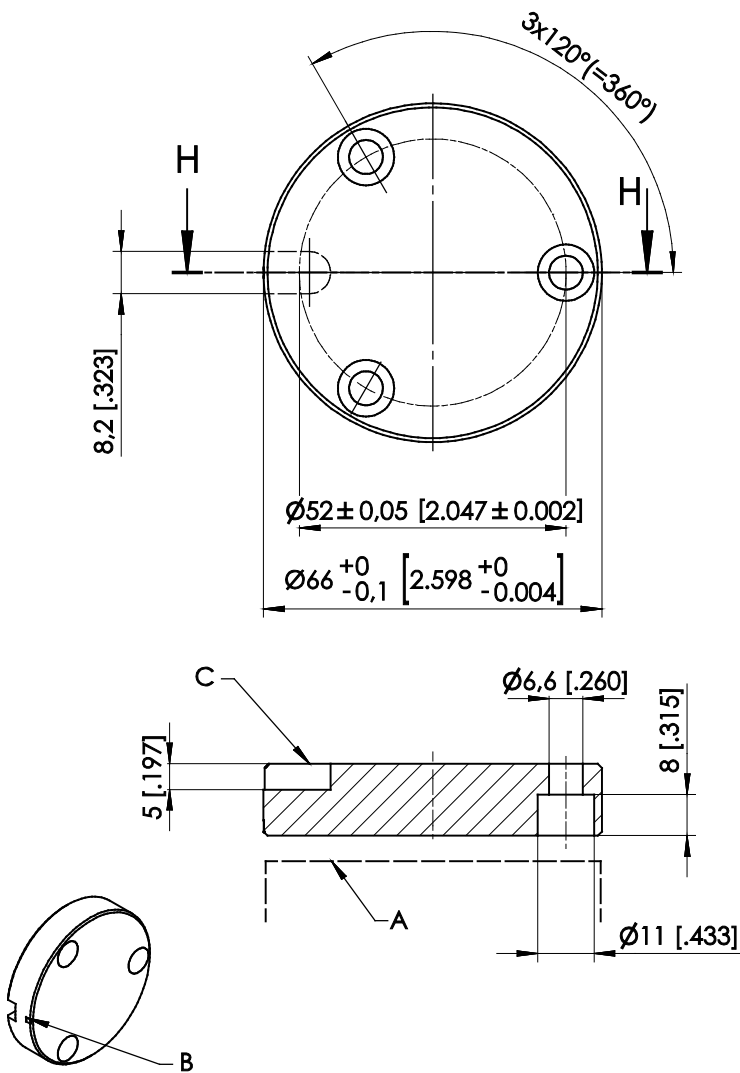

A – Sensor
B – Marking
C – Notch

Order code	Weight	Material	Moment of inertia
PRMAG6-Z	approx. 110 g	AlMgSi1,	65 kgmm ²
PRMAG6-Z-VA	approx. 315 g	stainless steel 1.4404	190 kgmm ²

A misalignment of the position magnet has an effect on the linearity.

Dimensions in mm [inch].

Dimensions informative only.

For guaranteed dimensions please consult factory.

PRMAG7-Z-VA

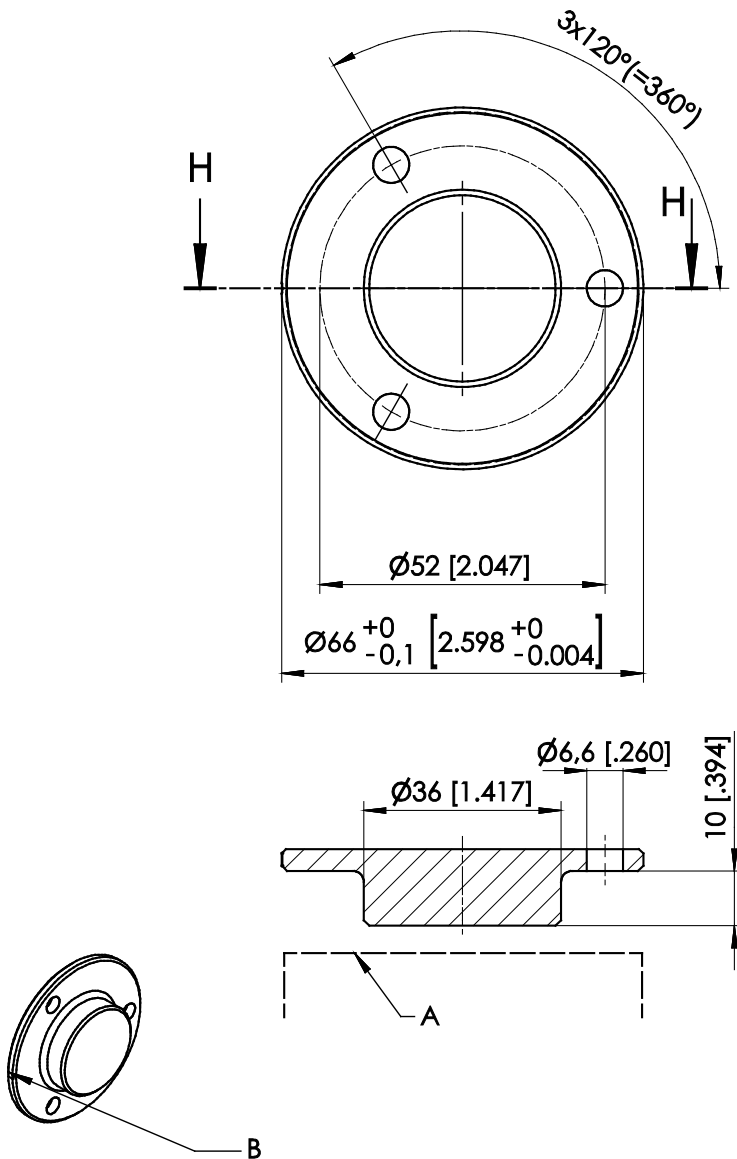

A – Sensor
B – Marking

Order code	Weight	Material	Moment of inertia
PRMAG7-Z-VA	approx. 146 g	stainless steel 1.4404	68 kgmm ²

A misalignment of the position magnet has an effect on the linearity.

Dimensions in mm [inch]
Dimensions informative only.
For guaranteed dimensions please consult factory.

Output specification

Incremental output

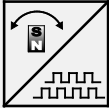
RS5V(F)/RS24V(F) Incremental 	Interface	EIA RS-422
	Excitation voltage	RS5V(F): 5 V DC $\pm 10\%$ RS24V(F): 10 ... 36 V DC
	Excitation current	100 mA max., depending on the load
	Pulse frequency	<500 kHz
	Output signals	A, \bar{A} , B, \bar{B} , Z, \bar{Z} Push-Pull
	Output current	10 mA max.
	Stability (temperature)	$\pm 50 \times 10^{-6} / ^\circ\text{C}$ f.s. (typical)
	Operating temperature	-40 ... +85 $^\circ\text{C}$
	Protection	Short circuit
	EMC	DIN EN 61326-1:2013

Output signals

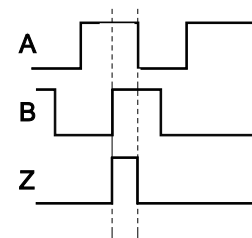
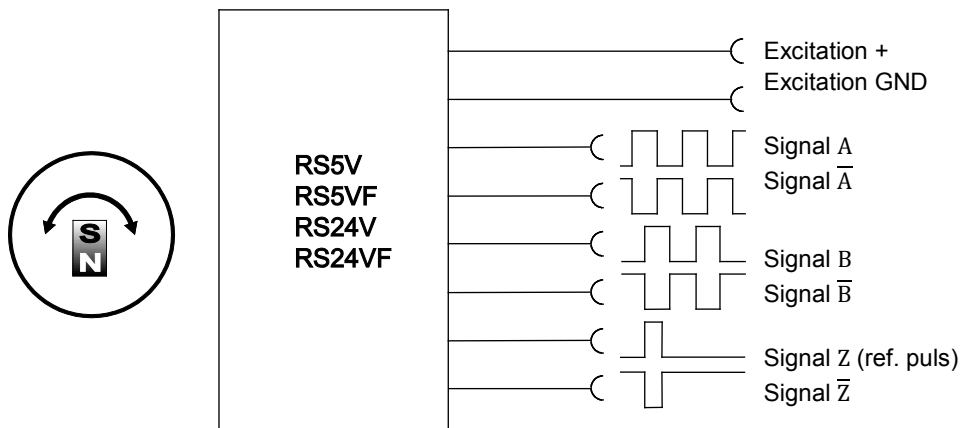

Unfiltered output RS5V / RS24V

A preferred maximum pulse frequency has to be defined within the product code. This will take account for limited bandwidth of downstream counter.

Filtered output RS5VF / RS24VF

Option for filtered jitter free position value. The filter does not introduce velocity or acceleration error.

Signal wiring

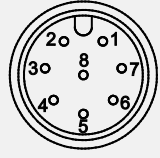
Signal	Connector pin no.	Cable color	View to the sensor connector
Excitation +	1	white	
Excitation GND	2	brown	
A	4	yellow	
\bar{A}	6	pink	
B	3	green	
\bar{B}	5	grey	
Z	7	blue	
\bar{Z}	8	red	

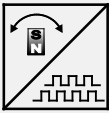
HT24V(F) Incremental 	Interface	HTL
	Excitation voltage	18 ... 36 V DC
	Excitation current	100 mA max., depending on the load
	Pulse frequency	<500 kHz
	Output signals	A, \bar{A} , B, \bar{B} , Z, \bar{Z} Push-Pull
	Output current	10 mA max.
	Stability (temperature)	$\pm 50 \times 10^{-6} / ^\circ\text{C}$ f.s. (typical)
	Operating temperature	-40 ... +85 °C
	Protection	Short circuit
	EMC	DIN EN 61326-1:2013

Output signals

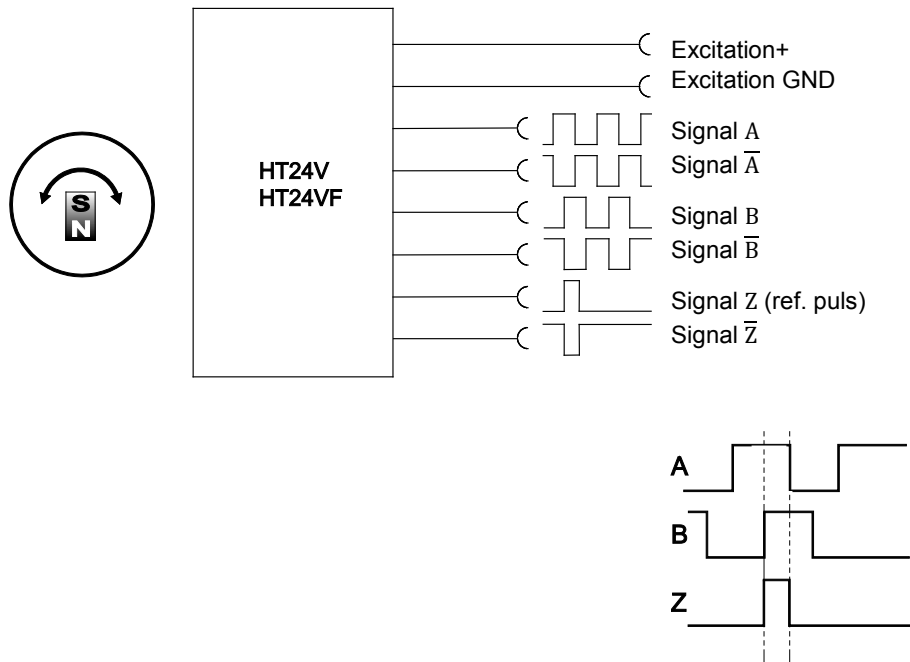

Unfiltered output HT24V

A preferred maximum pulse frequency has to be defined within the product code. This will take account for limited bandwidth of downstream counter.

Filtered output HT24VF

Option for filtered jitter free position value. The filter does not introduce velocity or acceleration error.

Signal wiring

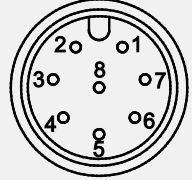
Output signals	Connector pin no.	Cable color	View to the sensor connector
Excitation +	1	white	
Excitation GND	2	brown	
A	4	yellow	
\bar{A}	6	pink	
B	3	green	
\bar{B}	5	grey	
Z	7	blue	
\bar{Z}	8	red	

SSI output

RSSI5V/RSSI24V Synchronous serial SSI 	Interface	EIA RS-422
	Excitation voltage	RSSI5V: 5 V DC $\pm 10\%$ RSSI24V: 10 ... 36 V DC
	Excitation current	100 mA max. without load
	Clock frequency	100 kHz ... 500 kHz
	Code	Gray-Code, continuous progression, 12 bit
	Delay between pulse trains	20 μ s min.
	Stability (temperature)	$\pm 50 \times 10^{-6}$ / $^{\circ}$ C f.s. (typical)
	Operating temperature	-40 ... +85 $^{\circ}$ C
	Protection	Short circuit
	EMC	EN 61326-1:2013

Data format (Train of 13 pulses)

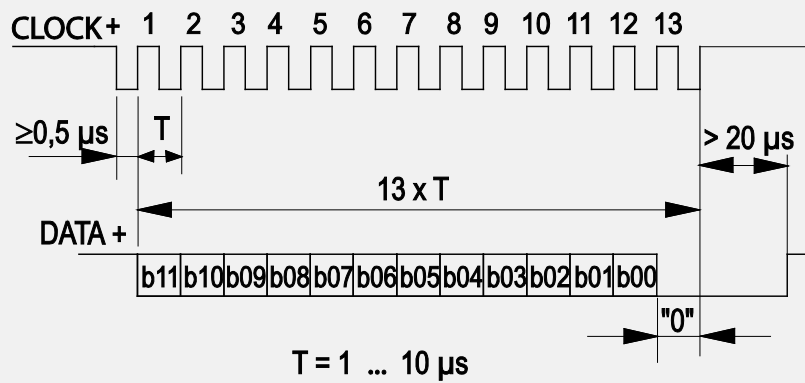

Recommended processing circuit

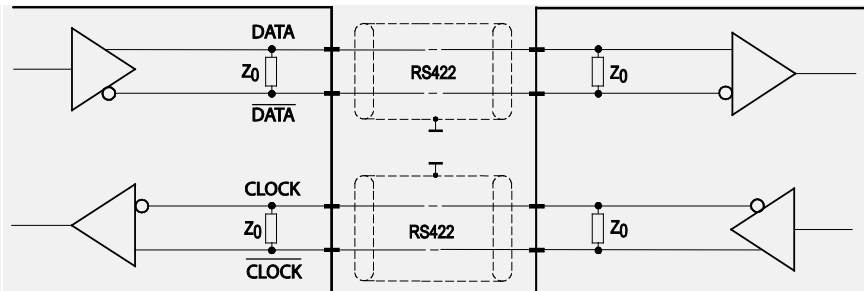

Transmission rate	Cable length	Baud rate	Note:
	50 m	100 - 1000 kHz	Extension of the cable length will reduce the maximum transmission rate. The signals CLOCK / $\overline{\text{CLOCK}}$ and DATA/ $\overline{\text{DATA}}$ must be connected in a twisted pair cable, shielded per pair and common.
	100 m	100 - 300 kHz	

Signal wiring	Connector pin no.	Cable color	View to the sensor connector
Excitation +	1	brown	
Excitation GND	2	white	
CLOCK	3	green	
$\overline{\text{CLOCK}}$	4	yellow	
DATA	5	grey	
$\overline{\text{DATA}}$	6	pink	
-	7	blue	
-	8	red	

Digital output CANopen

CANOP CANopen 	CAN Specification	ISO 11898, Basic and Full CAN 2.0 B
	Communication profile	CANopen CiA 301 V 4.02, Slave
	Device profile	Encoder CiA 406 V 3.2
	Configuration services	Layer Setting Service (LSS), CiA Draft Standard 305 (transmission rate, node id)
	Error Control	Node Guarding, Heartbeat, Emergency Message
	Node ID	Default: 127; programmable via LSS or SDO
	PDO	3 TxPDO, 0 RxPDO, static mapping
	PDO Modes	Event-/Time triggered, Remote-request, Sync cyclic/acyclic
	SDO	1 server, 0 Client
	CAM	8 cams
	Certified	Yes
	Transmission rates	50 kBaud to 1 MBaud, default: 125 kBaud; programmable via LSS or SDO
	Bus connection	M12 connector, 5 pin
	Integrated bus terminating resistor	Adjustable by the customer
	Bus, galvanic isolated	No

Specifications	Excitation voltage	8 ... 36 V DC
	Excitation current	20 mA typical at 24 V DC 40 mA typical at 12 V DC, 80 mA max.
	Resolution	0.05° max.
	Linearity	1° (optional 0.25°)
	Measuring rate	1 kHz (asynchronous)
	Stability (temperature)	$\pm 50 \times 10^{-6} / ^\circ\text{C}$ f.s. (typical)
	Repeatability	1 LSB
	Operating temperature	See specification of the respective sensor
	Protection	Reverse polarity, short circuit
	Dielectric strength	1 kV (V AC, 50 Hz, 1 min.)
EMC	DIN EN 61326-1:2013	

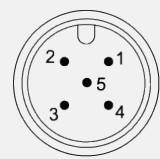
Signal wiring	Signal	Connector pin no.	Cable color	View to the sensor connector
	Shield	1	brown	
	Excitation +	2	white	
	GND	3	blue	
	CAN-H	4	black	
	CAN-L	5	grey	

CANOPR CANopen 	CAN Specification	ISO 11898, Basic and Full CAN 2.0 B
	Communication profile	CANopen CiA 301 V 4.02, Slave
	Device profile	Encoder CiA 406 V 3.2
	Configuration services	Layer Setting Service (LSS), CiA Draft Standard 305 (transmission rate, node id)
	Error Control	Node Guarding, Heartbeat, Emergency Message
	Node ID	Default: 127 and 126; programmable via LSS or SDO
	PDO	3 TxPDO, 0 RxPDO, static mapping
	PDO Modes	Event-/Time triggered, Remote-request, Sync cyclic/acyclic
	SDO	1 server, 0 Client
	CAM	8 cams
	Certified	Yes
	Transmission rates	50 kBaud to 1 MBaud, default: 125 kBaud; programmable via LSS or SDO
	Bus connection	M12 connector, 5 pin
	Integrated bus terminating resistor	adjustable by the customer
Bus, galvanic isolated	No	

Specifications	Excitation voltage	8 ... 36 V DC
	Excitation current	40 mA typical at 24 V DC 80 mA typical at 12 V DC, 120 mA max.
	Resolution	0.05° max.
	Linearity	1° (0.25° optional)
	Measuring rate	1 kHz (asynchronous)
	Stability (temperature)	±50 x 10 ⁻⁶ /°C f.s. (typical)
	Repeatability	1 LSB
	Operating temperature	See specification of the respective sensor
	Protection	Reverse polarity, short circuit
	Dielectric strength	1 kV (V AC, 50 Hz, 1 min.)
	EMC	DIN EN 61326-1:2013

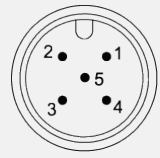
Signal wiring	Signal	Connector pin no.	Cable color	View to the sensor connector
	Shield	1	brown	
	Excitation +	2	white	
	GND	3	blue	
	CAN-H	4	black	
	CAN-L	5	grey	

Digital output CAN SAE J1939

CANJ1939 CAN SAE J1939 	CAN Specification	ISO 11898, Basic and Full CAN 2.0 B
	Transceiver	24V-compliant, not isolated
	Communication profile	SAE J1939
	Baud Rate	250 kbit/s
	Internal termination resistor	adjustable by the customer
	Address	Default 247d, configurable

NAME Fields	Arbitrary address capable	1	Yes
	Industry group	0	Global
	Vehicle system	7Fh (127d)	Non specific
	Vehicle system instance	0	
	Function	FFh (255d)	Non specific
	Function instance	0	
	ECU instance	0	
	Manufacturer	145h (325d)	Manufacturer ID
	Identity number	0nnn	Serial number 21 bit

Parameter Group Numbers (PGN)	Configuration data	PGN EF00h	Proprietary-A (PDU1 peer-to-peer)
	Process data	PGN FFnnh	Proprietary-B (PDU2 broadcast); nn Group Extension (PS) configurable

Specifications	Excitation voltage	8 ... 36 V DC
	Excitation current	20 mA typical at 24 V DC 40 mA typical at 12 V DC, 80 mA max.
	Resolution	0.05° max.
	Linearity	1° (0.25° optional)
	Measuring rate	1 kHz (asynchronous)
	Stability (temperature)	±50 x 10 ⁻⁶ /°C f.s. (typical)
	Repeatability	1 LSB
	Operating temperature	See specification of the respective sensor
	Protection	Reverse polarity, short circuit
	Dielectric strength	1 kV (V AC, 50 Hz, 1 min.)
	EMV	DIN EN 61326-1:2013

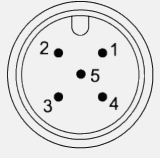
Signal wiring	Signal	Connector pin no.	View to the sensor connector
	Shield	1	
	Excitation +	2	
	GND	3	
	CAN-H	4	
	CAN-L	5	

CANJ1939R CAN SAE J1939 	CAN Specification	ISO 11898, Basic and Full CAN 2.0 B
	Transceiver	24V-compliant, not isolated
	Communication profile	SAE J1939
	Baud Rate	250 kbit/s
	Internal termination resistor	Adjustable by the customer
	Address	Default 247d and 246d, configurable

NAME Fields	Arbitrary address capable	1	Yes
	Industry group	0	Global
	Vehicle system	7Fh (127d)	Non specific
	Vehicle system instance	0	
	Function	FFh (255d)	Non specific
	Function instance	0	
	ECU instance	0	
	Manufacturer	145h (325d)	Manufacturer ID
	Identity number	0nnn	Serial number 21 bit

Parameter Group Numbers (PGN)	Configuration data	PGN EF00h	Proprietary-A (PDU1 peer-to-peer)
	Process data	PGN FFnnh	Proprietary-B (PDU2 broadcast); nn Group Extension (PS) configurable

Specifications	Excitation voltage	8 ... 36 V DC
	Excitation current	40 mA typical at 24 V DC 80 mA typical at 12 V DC, 120 mA max.
	Resolution	0.05° max.
	Linearity	1° (0.25° optional)
	Measuring rate	1 kHz (asynchronous)
	Stability (temperature)	±50 x 10 ⁻⁶ /°C f.s. (typical)
	Repeatability	1 LSB
	Operating temperature	See specification of the respective sensor
	Protection	Reverse polarity, short circuit
	Dielectric strength	1 kV (V AC, 50 Hz, 1 min.)
EMV	DIN EN 61326-1:2013	

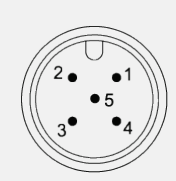
Signal wiring	Signal	Connector Pin no.	Cable color	View to the sensor connector
	Shield	1	brown	
	Excitation +	2	white	
	GND	3	blue	
	CAN-H	4	black	
	CAN-L	5	grey	

Characteristics for magnetic angle sensors

Output signal CW
(clockwise increasing)

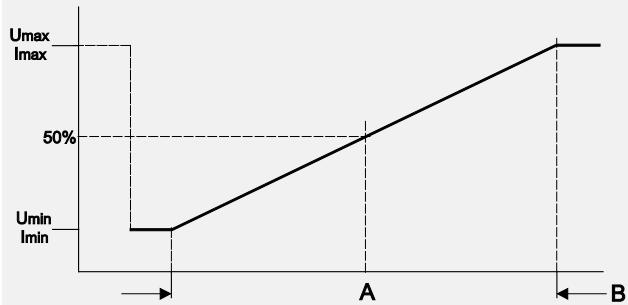

Output signal CCW
(counterclockwise increasing)

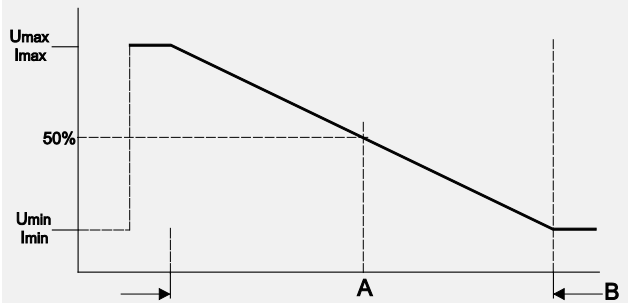

Example angular range 90°

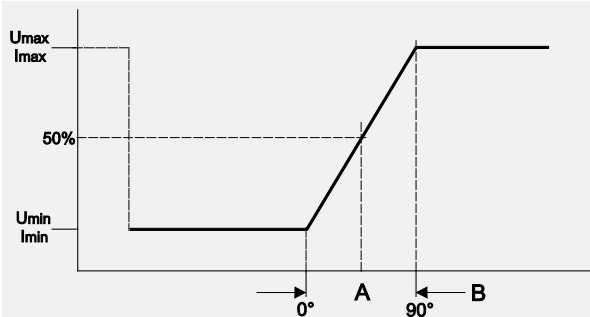

Example angular range 360°

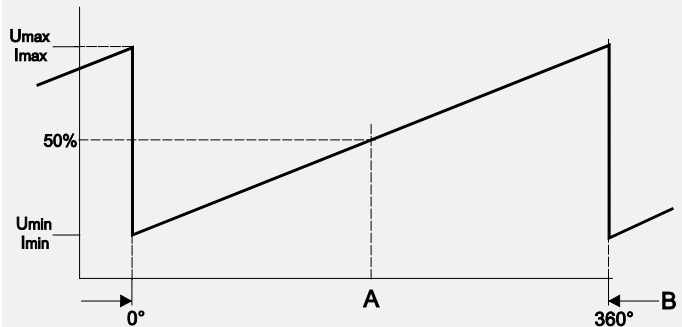

A – Marking
B – Measurement range [°]

Accessories

Connector cable M12, 8 pin (angular coupling)

shielded connector

The 8-lead shielded cable is supplied with a mating 8-pin 90° M12 connector at one end and 8 wires at the other end. Available lengths are 2 m, 5 m and 10 m. Wire: cross sectional area 0.25 mm² Cable diameter: 6.3 ±0.2 mm

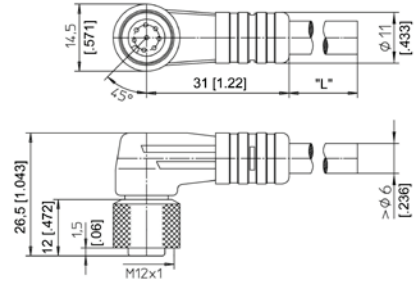

Order code

KAB - xM - M12/8F/W - LITZE

IP69: **KAB - xM - M12/8F/W/69K - LITZE**

xM = length in m

Connector cable M12, 8 pin (straight coupling)

shielded connector

The 8-lead shielded cable is supplied with a mating 8-pin M12 connector at one end and 8 wires at the other end. Available lengths are 2 m, 5 m and 10 m. Wire: cross sectional area 0.25 mm² Cable diameter: 6.3 ±0.2 mm

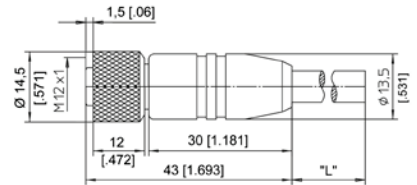

Order code

KAB - xM - M12/8F/G - LITZE

IP69: **KAB - xM - M12/8F/G/69K - LITZE**

xM = length in m

Signal wiring M12, 8 pin	Plug connection / cable color							
	1	2	3	4	5	6	7	8
	white	brown	green	yellow	grey	pink	blue	red

Applicable for cable carriers

Maximum movement speed	3 m/s
Maximum acceleration	5 m/s ²
Minimum bending radius	10 x cable diameter

Connector/bus cable M12, 5 pin CAN-Bus

The 5-lead shielded cable is supplied with a female 5 pin M12 connector at one end and a male 5 pin M12 connector at the other end.

Available lengths are 0.3 m, 2 m, 5 and 10 m.

Cable diameter: 6.7 ±0.2 mm

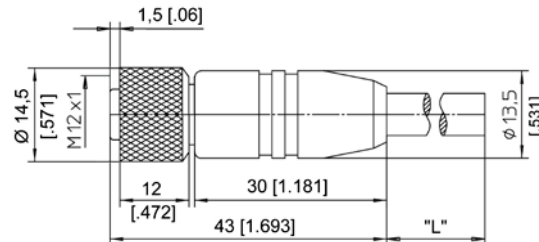

Order code:

KAB - xM - M12/5F/G - M12/5M/G - CAN

IP69: **KAB - xM - M12/5F/G/69K - M12/5M/G/69K - CAN**

xM = length in m

T-connector for bus cable M12, 5 pin CAN-Bus

Order code:

KAB - TCONN - M12/5M - 2M12/5F - CAN



Terminating resistor M12, 5 pin CAN-Bus

Order code:

KAB - RTERM - M12/5M/G - CAN



Applicable for cable carriers

Maximum movement speed	3 m/s
Maximum acceleration	5 m/s ²
Minimum bending radius	10 x cable diameter