

Model 8601

Pressure



Model 8601 Pressure Regulator

Mechanical Pressure Regulator

Overview

Brooks® 8601 Pressure Regulators are high precision supply pressure regulators which are direct-acting, non-relieving units that provide bubble-tight shut-off on helium at 100 psi. Compact and economical, these units are assembled in a “clean room” environment and are tested under simulated operating conditions.

Product Features

- Compact design
- Suitable for line or panel mounting
- Pressure gauge connection
- Bubble-tight shut-off to 100 psi
- Replaceable stainless steel inlet filter element

Product Specifications

Specifications	8601
Capacity	The pressure regulator is ideal for use at up to a maximum of 1,000 sccm air
Max. Inlet Supply Pressure	250 psi (1,724 kPa)
Max. Working Temperature	Standard: 140°F (60°C), Optional: 350°F (177°C)
Total Pressure Drop	Minimum: 10 psi, Maximum: 250 psi
Connections	Standard: 1/8" NPT; Optional 1/4" NPT, 1/8" or 1/4" compression fitting, 1/4" ID hose adaptors
Standard Seals & Fittings	Brass w/Buna-N, Stainless Steel w/Viton fluoroelastomer
Fittings	1/8" FNPT or 1/4" FNPT
Dimensions	See Dimensions Figure
Maximum Temperature	250°F/121°C
Typical Characteristics	Helium 60 psig supply, 50 psig output
Drift	Less than 1% in first fifteen minutes to total of no more than 1.5% long term
Supply Pressure Effect	10 psi increase in supply will not change output more than 0.07 psi
Flow Regulation	From 3 sccm to 70 sccm helium, output pressure will not decrease more than: 0.08 psig (0-10, 0-30 psi Regulators) 0.10 psig (0-60 psi Regulators), 0.125 psig (0-100 psi Regulators), 0.15 psig (0-150 psi Regulators), 0.175 psig (0-200 psi Regulators)
Ambient Temperature Effect	Standard 60 psi range, 0.020 psi/°F
Base Line Oscillation	.0025 psi
Valve Adjustment & Oper. Range	Fifteen turns for 0-10, 0-30, 0-60, 0-100, 0-150 or 0-200 psig output range
Materials of Construction	
Body	Standard: Aluminum; Optional: 316 Stainless Steel
Bonnet	Aluminum
Valve Seat	Standard: Brass; Optional 316 Stainless Steel
Valve Stem	316 Stainless Steel
Diaphragm	Reinforced Buna-N, Viton-A® fluoroelastomers
Range Spring	Music Wire, zinc plated
Filter	40 micron, 316L Sintered Stainless Steel with Viton fluoroelastomers or Buna retainer sleeve
Compatible Brooks Equipment	Model 1390 Filter and Model 1391 Filter

Brooks Service and Support

Brooks is committed to assuring all of our customers receive the ideal flow solution for their application, along with outstanding service and support to back it up. We operate first class repair facilities located around the world to provide rapid response and support. Each location utilizes primary standard calibration equipment to ensure accuracy and reliability for repairs and recalibration and is certified by our local Weights and Measures Authorities and traceable to the relevant International Standards.

Visit www.BrooksInstrument.com to locate the service location nearest to you.

START-UP SERVICE AND IN-SITU CALIBRATION

Brooks Instrument can provide start-up service prior to operation when required. For some process applications, where ISO-9001 Quality Certification is important, it is mandatory to verify and/or (re)calibrate the products periodically. In many cases this service can be provided under in-situ conditions, and the results will be traceable to the relevant international quality standards.

SEMINARS AND TRAINING

Brooks Instrument can provide seminars and dedicated training to engineers, end users, and maintenance persons.

Please contact your nearest sales representative for more details.

Due to Brooks Instrument's commitment to continuous improvement of our products, all specifications are subject to change without notice.

TRADEMARKS

Brooks Brooks Instrument, LLC
All other trademarks are the property of their respective owners.



Global Headquarters

Brooks Instrument
407 West Vine Street
Hatfield, PA
19440-0903 USA

Toll-Free (USA): 888-554-FLOW
T: 215-362-3500
F: 215-362-3745

BrooksAM@BrooksInstrument.com

A list of all Brooks Instrument locations and contact details can be found at www.BrooksInstrument.com

© Copyright 2017 Brooks Instrument, LLC All rights reserved. Printed in U.S.A.

Product Dimensions

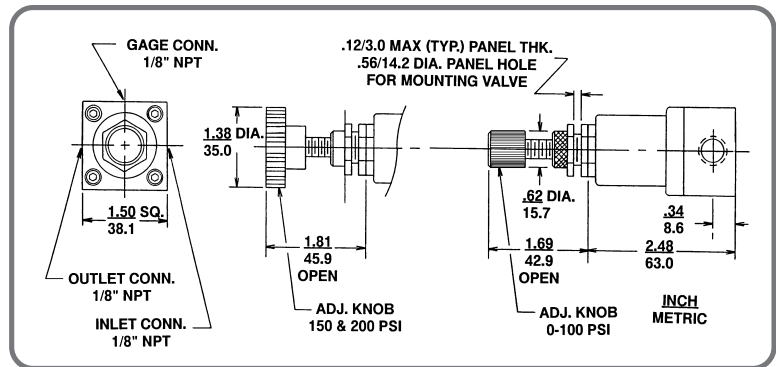

Ordering Information

To order, please specify:

1. Model Number
2. Materials of Construction
3. Output Range
4. Connection Type & Size
5. Options, If desired.

Model Code

Code Description	Code Option	Option Description
I. Base Model Number	8601D	Pressure Regulator - Side Connections
II. Body Material - Wetted	1	Aluminum
	2	Stainless Steel
III. Diaphragm & Valve Seat Materials	A	Buna-N and Brass/Buna-N (Aluminum only)
	B	Viton and Brass/Viton (Aluminum only)
	C	Buna-N and Stainless Steel/Buna-N
	D	Viton and Stainless Steel/Viton
IV. Range	1	0-10 psi
	2	0-30 psi
	3	0-60 psi
	4	0-100 psi
	5	0-150 psi
	6	0-200 psi
V. Connection Size & Type	A	1/8" NPT integral
	B	1/4" NPT
	C	1/8" compression tube
	D	1/4" compression tube
	E	1/4" ID hose
VI. Accessories (Up to 3 Digit Code)	A	None
	B	Panel mounting
	C	Degrease for oxygen service
	D	No valve knob
	E	No Brooks logo
	F	Gage port plugged

Sample Standard Model Code

I	II	III	IV	V	VI
8601D	1	A	1	A	A

BROOKS[®]
INSTRUMENT