

Radio Sensortelemetrie

* Short description of radio telemetry	page 2 ... 3
* Rotating part to stationary part	page 4 ... 20
* Point to point	page 21
* Antenna diversity	page 22
* Multi channel telemetry	page 23 ... 26
* RMC	page 27 ... 28
* Radio telemetry components	page 29 ... 53

Short Description of Manner Radio-Sensortelemetrie

The Manner Radio Telemetry was especially developed for working in heavy environment conditions. It consists of radio transmitter and miniaturized sensor signal amplifier. The strain gage bridges and thermocouples, RTD (PT100) are direct interfaced with the sensor signal amplifier.

The signal from the transducer will be enforced, filtered due to the antialiasing and digitized. The resolution of the signal can be 12 Bit or 16 Bit (option). Thereafter the digital data will be encoded and a special checksum word will be generated.

This special checksum word guarantees absolute noise-free data transmission. The data word and special checksum word will be FM-modulated of the RF carrier 433/868 MHz. The guaranteed wireless transmitting range depends on the data rate. It ranges from 5 to over 50 meters in free terrain. The system is available in single and multi channel version (2, 4, 8, 16, 32 channels). For each channel exists a separate power supply, amplifier, AD-Converter and DA-Converter. There is no crosstalk between the channels and no backlash in case of a short circuit. The range adjustment, auto zero can be programmed remote from a PC.

Diagramm of one channel

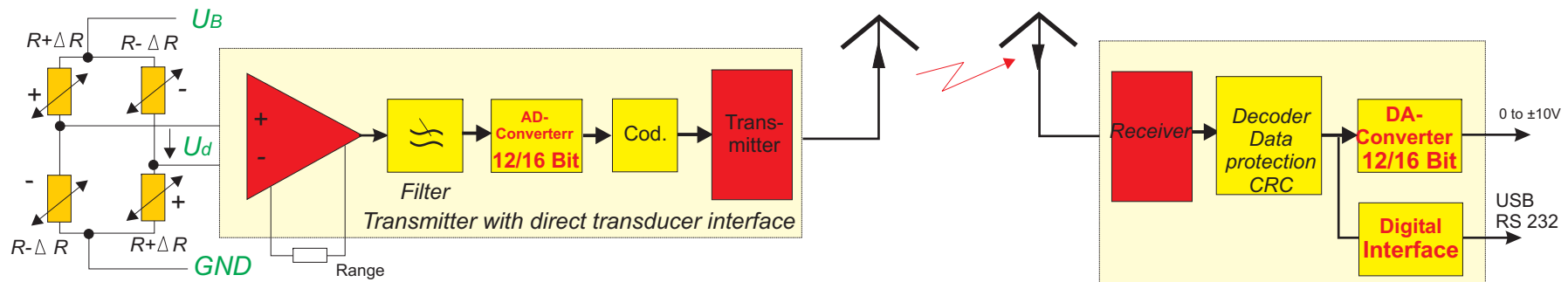

Configuration

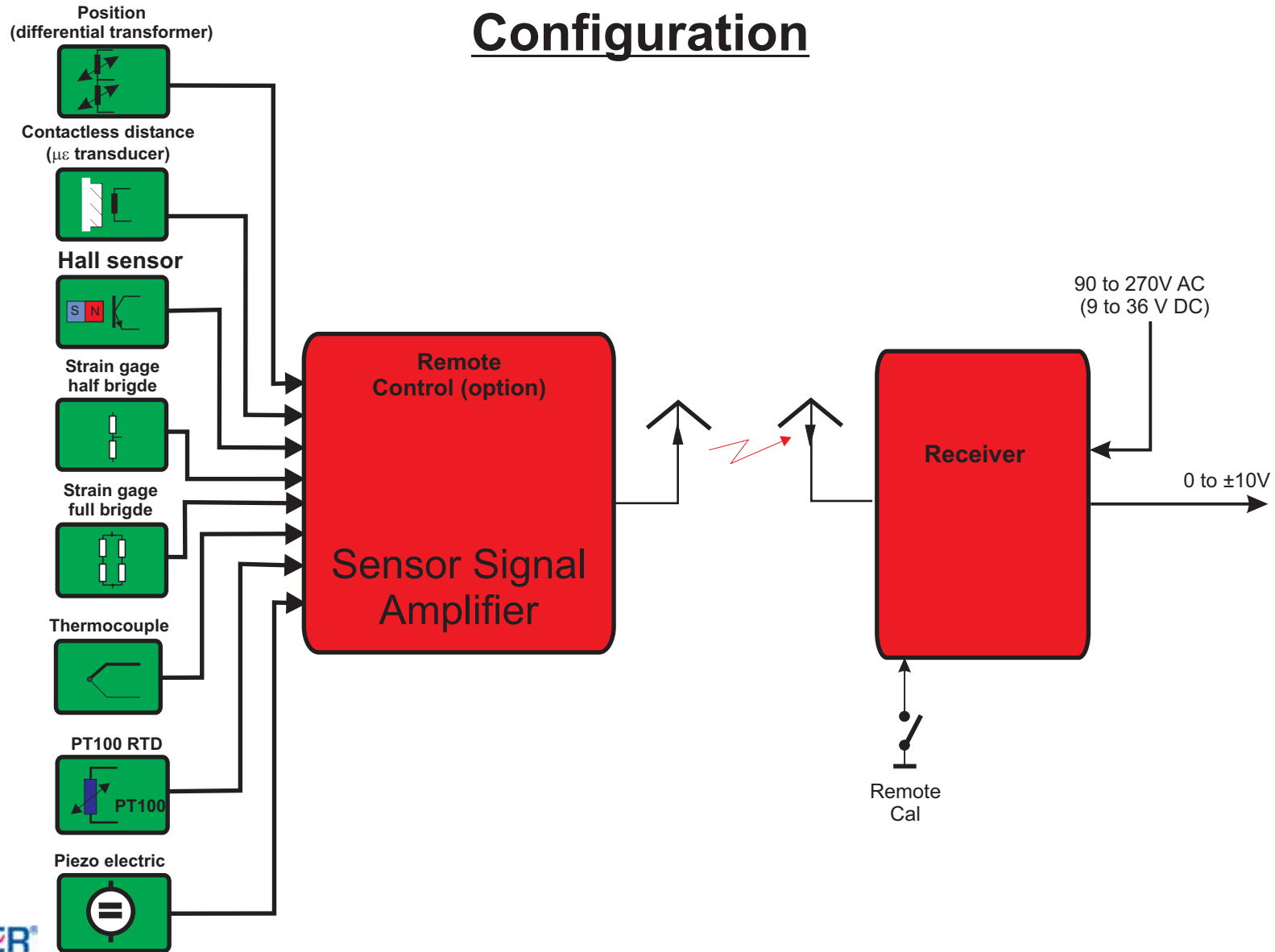

MANNER Radio Sensortelemetrie (shaft - stationary)

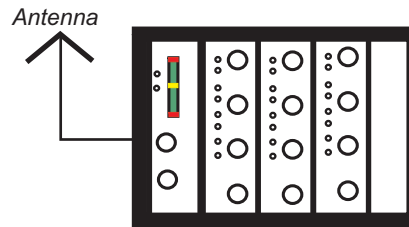
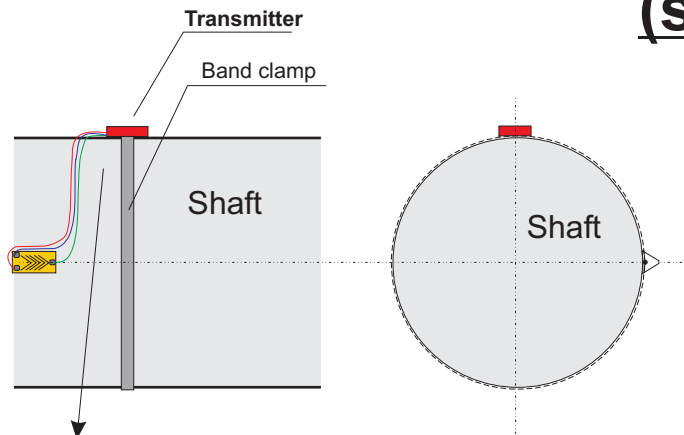

Receiver

Type: AW_T_<bandwidth>_<channels>_<supply>_<output>_<mod>_F



Type: SV_4_<bandwidth>_<accuracy>_<temp>_<mod>_F



Features:

Easy mounting

with Accu-supply 3,6 V Lithium, max 35 hours (one cycle)

Channel count: max. 16

Sample rate: 40000 Sample/s (1 channel)

Sample rate: 20000 Sample/s /channel at 8 channels

Digital transmitting: 12/16 Bit resolution with checksum (CRC)

Transmitting: Radio $f = 433/868$ MHz, 16 different frequencies

RF-Power: 10 mW; range: 50 m in open field

Integrated data protection by checksum 16 Bit CRC

Low current consumption by low power C-MOS technique: 3,6 V supply

Integrated transducer amplifier range: 0,1 mV/V to 20 mV/V

Range adjustable by solderable resistors

or optional electrical remote programmable range with 12 Bit resolution

Transducer: Strain gage, full- / half bridge, Thermocouple type K

Zero drift / Gain drift: 0,01 %/°C (0,003 %/°C optional)

Optional inductive supply

Max. acceleration: 3000 g

Optional -40 to +120°C environmental temperature

MANNER Radio Sensortelemetry (shaft - stationary)

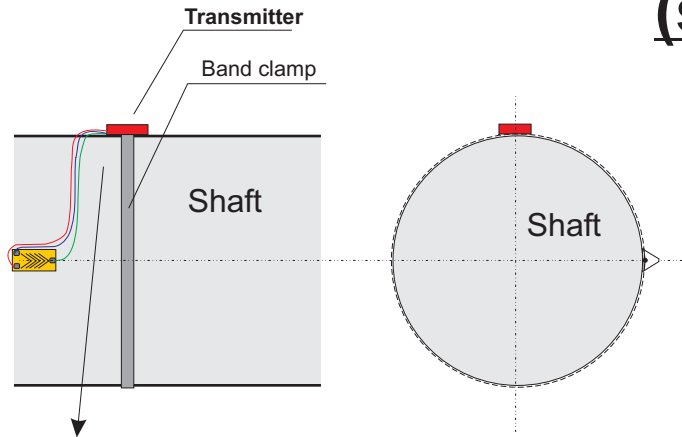

Type: SV_4_<bandwidth>_<accuracy>_<temp>_<mod>_F



Type: AW_M_<bandwidth>_<supply>_<output>_<mod>_F

Features:

- Easy mounting
- with Accu-supply 3,6 V Lithium, max 35 hours (one cycle)
- Channel count: 1
- Sample rate: 4000 Sample/s (1 channel)
- Digital transmitting 12/16 Bit resolution with checksum (CRC)
- Transmitting: Radio f = 433/868 MHz, 16 different frequencies
- RF-Power: 10 mW; range: 50 m in open field
- Integrated data protection by checksum 16 Bit CRC
- Low current consumption by low power C-MOS technique: 3,6 V supply
- Integrated transducer amplifier range: 0,1 mV/V to 20 mV/V
- Range adjustable by solderable resistor
- or optional electrical remote programmable range with 12 Bit resolution
- Transducer: Strain gage, full- / half bridge, Thermocouple type K
- Zero drift / Gain drift: 0,01 %/°C (0,003 %/°C optional)
- Optional inductive supply
- Max. acceleration: 1500 g
- Temperature range: -10 to +85°C
- Optional -40 to +120°C environmental temperature

MANNER Radio Sensortelemetrie (flexible power meter)

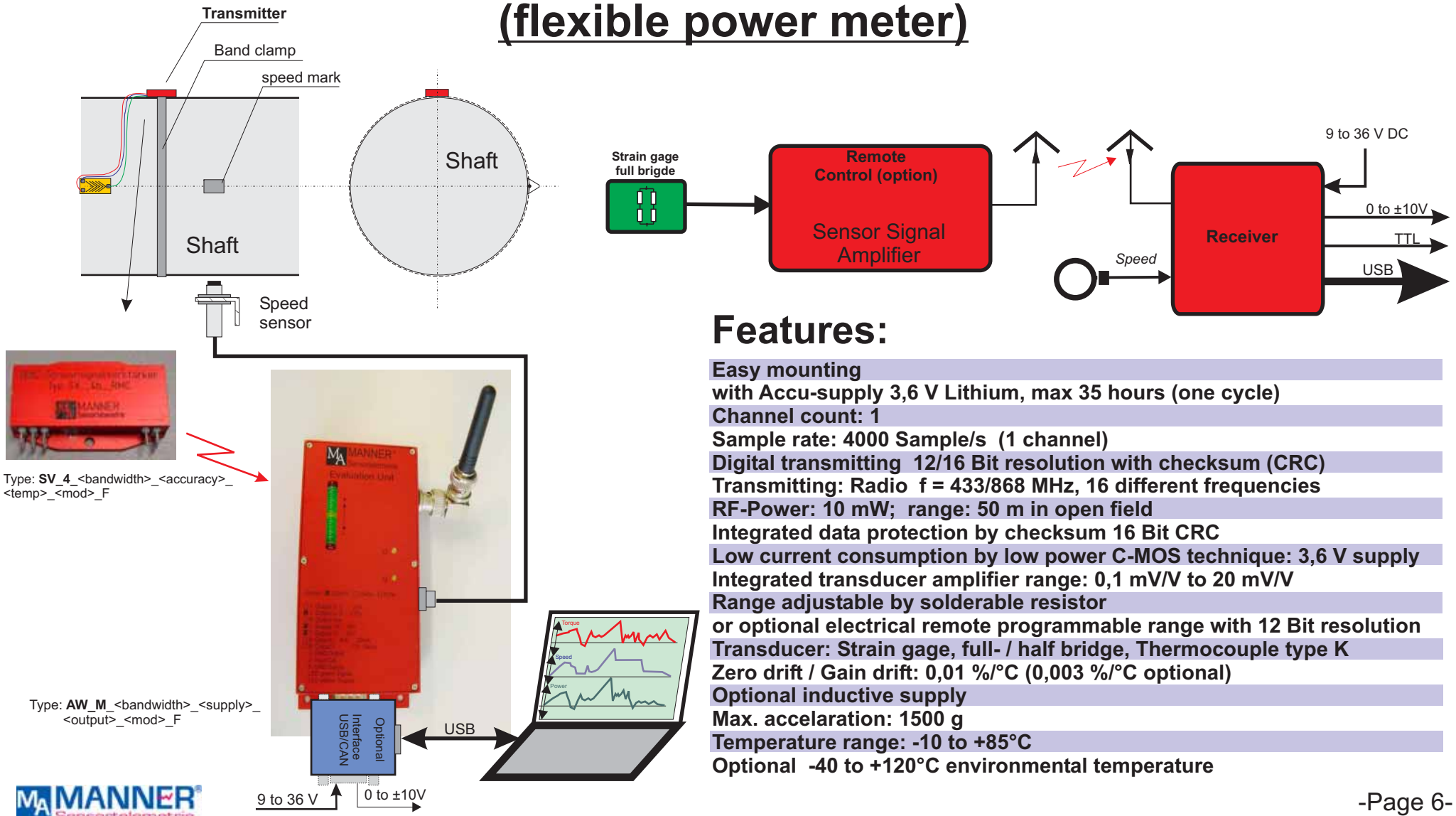

Features:

- Easy mounting
- with Accu-supply 3,6 V Lithium, max 35 hours (one cycle)
- Channel count: 1
- Sample rate: 4000 Sample/s (1 channel)
- Digital transmitting 12/16 Bit resolution with checksum (CRC)
- Transmitting: Radio $f = 433/868$ MHz, 16 different frequencies
- RF-Power: 10 mW; range: 50 m in open field
- Integrated data protection by checksum 16 Bit CRC
- Low current consumption by low power C-MOS technique: 3,6 V supply
- Integrated transducer amplifier range: 0,1 mV/V to 20 mV/V
- Range adjustable by solderable resistor
- or optional electrical remote programmable range with 12 Bit resolution
- Transducer: Strain gage, full- / half bridge, Thermocouple type K
- Zero drift / Gain drift: 0,01 %/°C (0,003 %/°C optional)
- Optional inductive supply
- Max. acceleration: 1500 g
- Temperature range: -10 to +85°C
- Optional -40 to +120°C environmental temperature



Type: SV_4_<bandwidth>_<accuracy>_<temp>_<mod>_F

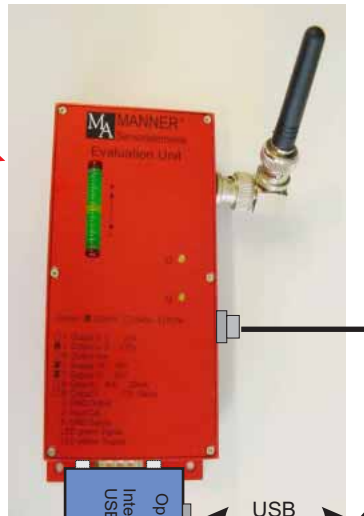

Type: AW_M_<bandwidth>_<supply>_<output>_<mod>_F



Torque Meter based on Radio Telemetry



Type: MF_<range>_<bandwidth>_<precision>_<mod>_F

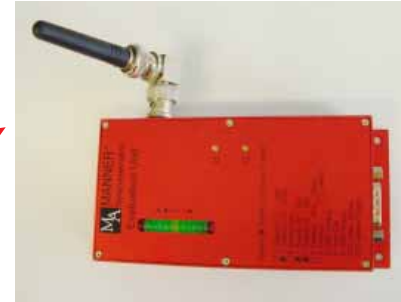

Type: AW_M_<bandwidth>_<supply>_<output>_<mod>_F

Features:

- Universal torque meter for short term use
- Ranges available: 10 Nm to 50 kNm
- Linearity and hysteresis: 0,2 %
- High bandwidth 0 to 1 kHz(-3 dB)
- High reliable digital transmitting 16 Bit resolution
- Zero drift / Gain drift: 0,01 %/°C (0,003 %/°C optional)
- Easy mounting
- Transmitting: Radio f = 433/868 MHz
- RF-Power: 10 mW; range: 40 m in open field
- Integrated data protection by checksum (16 Bit CRC)
- Low current consumption by low power C-MOS technique: 3,6 V supply with Accu-supply 3,6 V Lithium, max 35 hours (one cycle)
- Max. radial acceleration: 1500 g
- Temperature range: -10 to +85°C
- Optional -40 to +120°C environmental temperature
- Supply receiver: 9 to 36 V DC, 100 mA
- Output voltage: 0 to ±10 V, 0(4) to 20 mA, USB, CAN

Type system: type: MF_<range>_<precision>_<bandwidth>_<mod>_<AW>_F_<Inter>

10 Nm	0,25%	10 Hz	PCM12	AW_M	---
to	0,1%	100 Hz	PCM16	AW_T	USB
50 kNm	0,05%	1 kHz			CAN

Further information:
see "Messflansch"

Force Meter based on Radio Telemetry



Type: MF_<range>_<bandwidth>_<precision>_<mod>_F

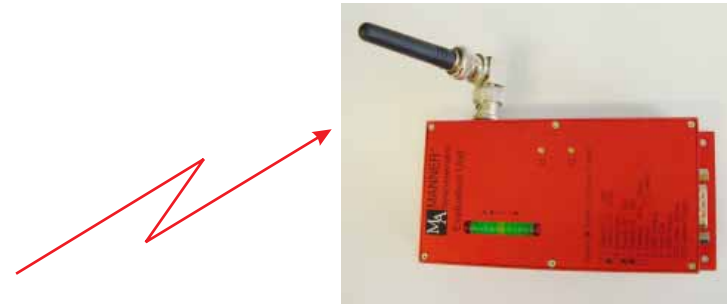

Type: AW_M_<bandwidth>_<supply>_<output>_<mod>_F

Features:

- Universal torque meter for short term use
- Ranges available: 10 N to 5 000 kN
- Linearity and hysteresis: 0,2 %
- High bandwidth 0 to 1 kHz(-3 dB)
- High reliable digital transmitting 16 Bit resolution
- Zero drift / Gain drift: 0,01 %/°C (0,003 %/°C optional)
- Easy mounting
- Transmitting: Radio f = 433/868 MHz
- RF-Power: 10 mW; range: 40 m in open field
- Integrated data protection by checksum (16 Bit CRC)
- Low current consumption by low power C-MOS technique: 3,6 V supply with Accu-supply 3,6 V Lithium, max 35 hours (one cycle)
- Max. radial acceleration: 1500 g
- Temperature range: -10 to +85°C
- Optional -40 to +120°C environmental temperature
- Supply receiver: 9 to 36 V DC, 100 mA
- Output voltage: 0 to ±10 V, 0(4) to 20 mA, USB, CAN, TCP/IP

Type system: type: MFF_<range>_<precision>_<bandwidth>_<mod>_<AW>_F_<Inter>

10 N	0,25%	10 Hz	PCM12	AW_M	---
to	0,1%	100 Hz	PCM16	AW_T	USB
10 000 kN	0,05%	1 kHz			CAN

Climate Compressor Torque Meter based on Radio Telemetry



Type: MFC_<range>_<precision>_<bandwidth>_<mod>_F

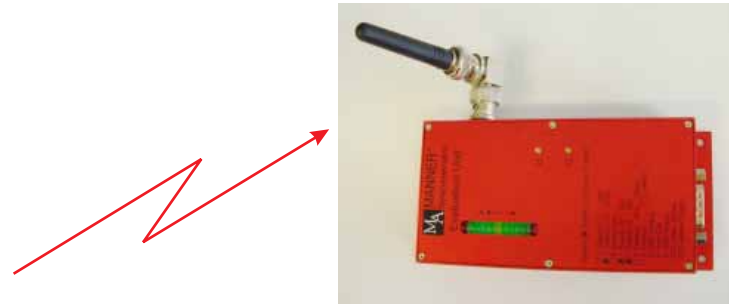

Type: AW_M_<bandwidth>_<supply>_<output>_<mod>_F

Features:

- Climate compressor torque meter for short term use
- Ranges available: 20 Nm to 50 kNm
- Linearity and hysteresis: 0,25 %
- High bandwidth 0 to 1 kHz(-3 dB)
- High reliable digital transmitting 16 Bit resolution
- Zerodrift / Gaindrift: 0,01 %/°C (0,003 %/°C optional)
- Easy mounting
- Transmitting: Radio f = 433/868 MHz
- RF-Power: 10 mW; range: 40 m in open field
- Integrated data protection by checksum (16 Bit CRC)
- Low current consumption by low power C-MOS technique: 3,6 V supply with Accu-supply 3,6 V Lithium, max 25 hours (one cycle)
- Max. radial acceleration: 1500 g
- Temperature range: -10 to +85°C
- Optional -40 to +120°C environmental temperature
- Supply receiver: 9 to 36 V DC, 100 mA
- Output voltage: 0 to ±10 V, 0(4) to 20 mA, USB, CAN

Type system: type: MFC_<range>_<precision>_<bandwidth>_<mod>_<AW>_F_<Inter>					
20 Nm	0,25%	10 Hz	PCM16	AW_M	---
to	0,1%	100 Hz		AW_P	USB
50 Nm		1 kHz			CAN

Acceleration Meter based on Radio Telemetry



Type: AW_M_<bandwidth>_<supply>_<output>_<mod>_F

Features:

Universal acceleration meter for short term use

Ranges available: 1 g ... 500 g

Linearity and hysteresis: 0,2 %

High bandwidth 0 to 1 (10) kHz(-3 dB)

High reliable digital transmitting 16 Bit resolution

Zero drift / Gain drift: 0,01 %/°C (0,003 %/°C optional)

Easy mounting (srew or clamping)

Transmitting: Radio f = 433/868 MHz

RF-Power: 10 mW; range: 40 m in open field

Integrated data protection by checksum (16 Bit CRC)

Low current consumption by low power C-MOS technique: 3,6 V supply with Accu-supply 3,6 V Lithium, max 35 hours (one cycle)

Temperature range: -10 to +85°C

Optional -40 to +120°C environmental temperature

Supply receiver: 9 to 36 V DC, 100 mA

Output voltage: 0 to ±10 V, 0(4) to 20 mA, USB, CAN

Type system: type: MFA_<range>_<precision>_<bandwidth>_<mod>_<AW>_F_<Inter>						
	1 g	0,25%	10 Hz	PCM12	AW_M	---
	to		100 Hz	PCM16	AW_T	USB
	500 g	0,1%	1 kHz			CAN
			10 kHz			TCP/IP

Torsional Acceleration Meter based on Radio Telemetry with ICP Sensors

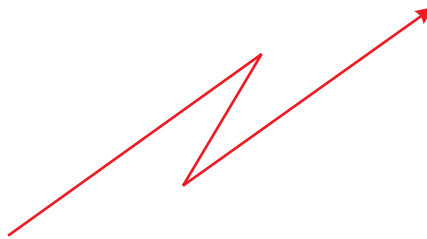
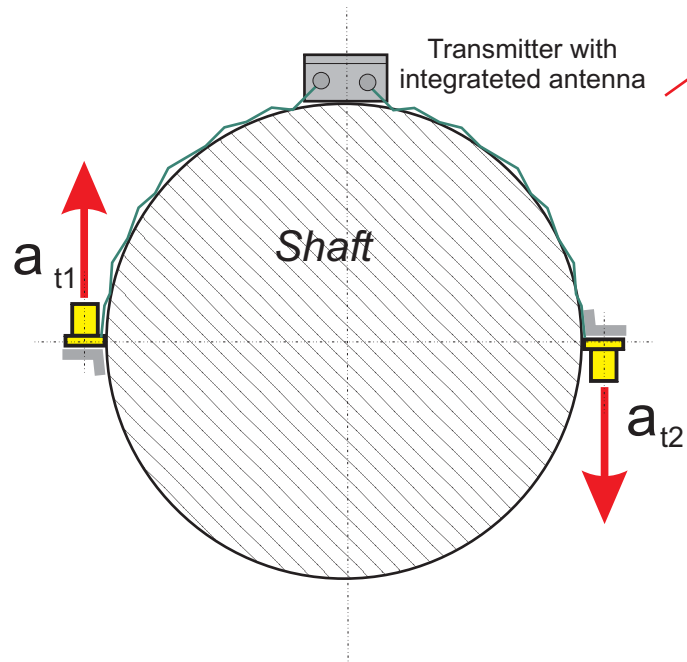

Receiver

Features:

- Universal torsional acceleration meter for short term use
- Ranges available: 1 g ... 100 g
- Linearity and hysteresis: 0,2 %
- High bandwidth 0 to 1 kHz (-3 dB)
- Zero drift / Gain drift: 0,01 %/°C (0,003 %/°C optional)
- Easy mounting (srew or clamping)
- Transmitting: Radio $f = 433/868$ MHz
- RF-Power: 10 mW; range: 40 m in open field
- High reliable digital transmission, integrated data protection by checksum
- low current consumption by low power C-MOS technique: 3,6 V supply with Accu-supply 3,6 V Lithium, max 35 hours (one cycle)
- Eviromental temperature range: -10 to +85°C (-40..+125°C opt.)
- Supply receiver: 9 to 36 V DC, 100 mA
- Output voltage: 0 to ± 10 V, 0(4) to 20 mA, USB, CAN, TCP/IP

Type system: type: MFB_<range>_<precision>_<bandwidth>_<mod>_<AW>_F_<Inter>

1 g	0,25%	10 Hz	PCM12	AW_M	---
to		100 Hz	PCM16	AW_T	USB
500 g	0,1%	1 kHz			CAN
		10 kHz			TCP/IP

Wheel Torque Meter based on Radio Telemetry



Type: MFW_<range>_<precision>_<bandwidth>_<mod>_F



Type: AW_M_<bandwidth>_<supply>_<output>_<mod>_F

Features:

- Wheel torque meter for cars
- Ranges available: 500 Nm to 4 kNm
- Linearity and hysteresis: 0,1 %
- Based on titanium with overload protection
- High bandwidth 0 to 1 kHz(-3 dB)
- High reliable digital transmitting 16 Bit resolution
- Zerodrift / Gain drift: 0,01 %/°C (0,003 %/°C optional)
- Easy mounting
- Transmitting: Radio f = 433/868 MHz, 16 different frequencies
- Integrated transmitting antenna, waterproof
- RF-Power: 10 mW; range: 20 m in open field
- Integrated data protection by checksum (16 Bit CRC)
- Low current consumption by low power C-MOS technique: 3,6 V supply with Accu-supply 3,6 V Lithium, max 35 hours (one cycle)
- Max. radial acceleration: 1500 g
- Temperature range: -25 to +85°C
- Optional -40 to +120°C environmental temperature
- Supply receiver: 9 to 36 V DC, 100 mA
- Output voltage: 0 to ±10 V, 0(4) to 20 mA, USB, CAN

Type system: type: MFW_<range>_<precision>_<bandwidth>_<mod>_<AW>_F_<Inter>

500 Nm	0,1%	100 Hz	PCM16	AW_M	---
to		1 kHz		AW_P	USB
4 kNm					CAN

Wheel Radio Telemetry with CAN-Bus Interface

Multichannel transmitter with integrated strain gage amplifier (with Accu)

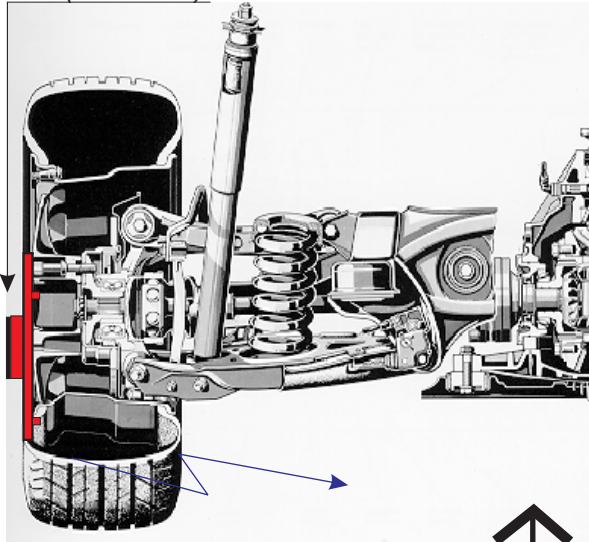

or

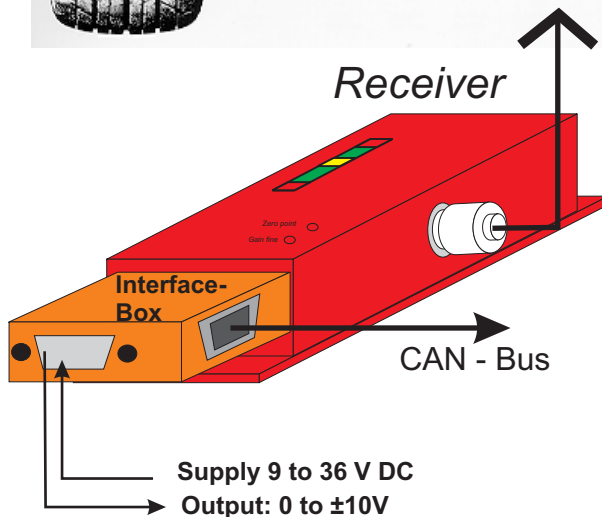

Features:

- Easy mounting with Accu-supply 3,6 V Lithium, max 35 hours (one cycle)
- Channel count: 1 or multi channel (max. 16)
- Sample rate: 4000 Sample/s/channel
- Digital transmitting 12/16 Bit resolution with checksum (CRC)
- Transmitting: Radio f = 433/868 MHz, 16 different frequencies
- RF-Power: 10 mW; range: 30 m in open field
- Low current consumption by low power C-MOS technique: 3,6 V supply
- Integrated transducer amplifier range: 0,1 mV/V to 20 mV/V
- electrical remote programmable range with 12 Bit resolution
- Transducer: strain gage, full- / half bridge, Thermocouple type K
- Zerodrift / Gain drift: 0,01 %/°C (0,003 %/°C optional)
- Optional inductive supply
- Max. acceleration: 1500 g
- Optional -40 to +120°C environmental temperature

Type system: type: MFW_<channel>_<precision>_<temperature>_<mod>_F_<sample>_<Inter>

	2	0,2	85	PCM12	1	USB
	to	0,1	125	PCM16	10	CAN
	32		150		1000	
					4000	
					8000	

Wireless Temperature Sensor for rough Environment Condition opt. with CAN Bus or USB Interface

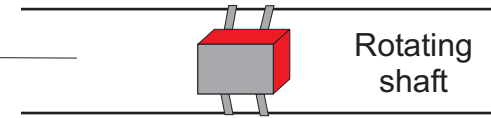
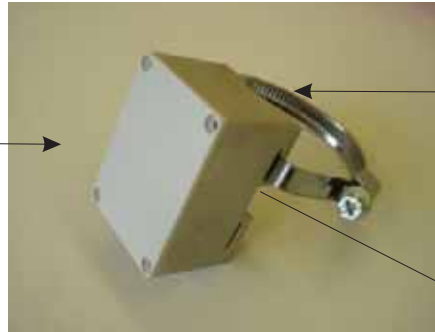
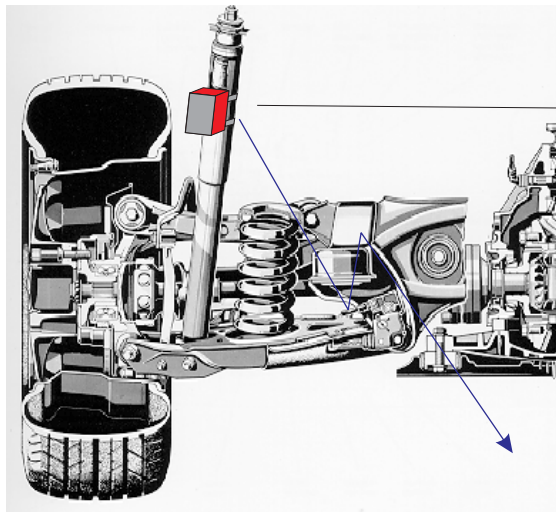

Temperature acquisition at the shaft

Direct contacting temperature sensor

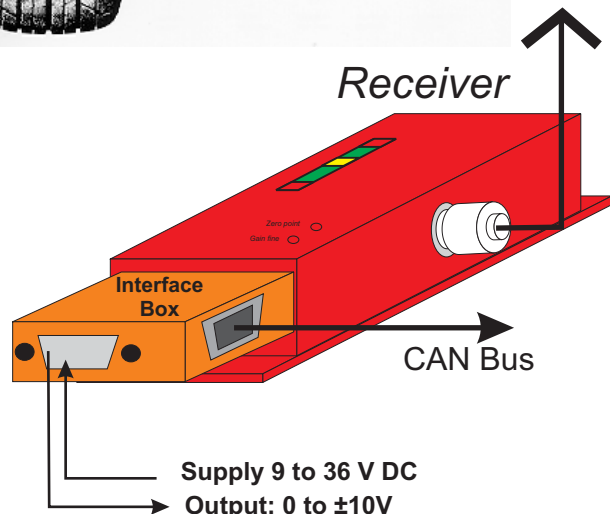

Features:

Easy mounting by clamps

with exchangeable Battery, supply 3,6 V

Low current consumption, 1/2 year operating time per battery set

Channel count: 1 or multi channel (max. 16)

Sample rate: 1 Sample/s (option 10 Sample/sec)

Digital transmitting 12/16 Bit resolution with checksum (CRC)

Transmitting: Radio f = 433 MHz, 16 different frequencies

RF-Power: 10 mW; range: 30 m in open field

Low current consumption by low power C-MOS technique: 3,6 V supply

Temperature ranges: -40 to 85°C, -40 to 120°C

Integrated temperatur sensor (optional external temperature sensor)

Accuracy: ±1,5°C

Max. acceleration: 500 g

Size: 45 x 30 x 25 mm

Optional -40 to +120°C environmental temperature

Type: SV_8x_<channels>_<samplerate>_<temp>_<mod>_<sensor>

1	1	85	int
2	10	120	ext
4			
8			
16			

Wireless Temperature Sensor for rough Environment Condition opt. with CAN Bus or USB Interface

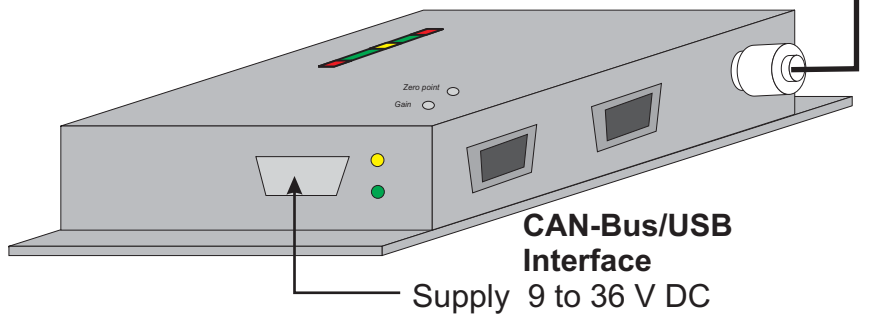
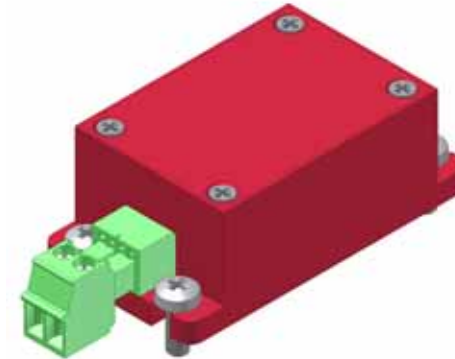
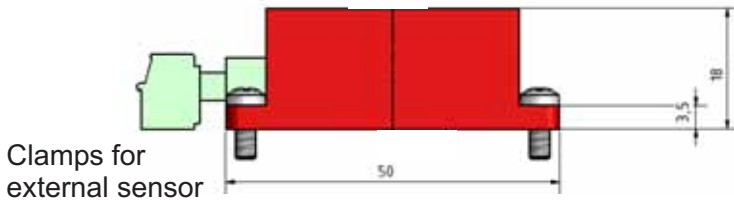
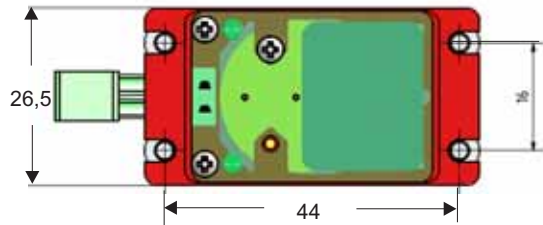

Features:

- Easy mounting by clamps
- with exchangeable Battery, supply 3,6 V
- Low current consumption, >1/2 year operating time per battery set
- Channel count: 1 or multi channel (max. 16)
- Sample rate: 1 Sample/s (option 10 Sample/sec)
- Digital transmitting 16 Bit resolution with checksum (CRC)
- Transmitting: Radio f = 433 MHz, 16 different frequencies
- RF-Power: 10 mW; range: 50 m in open field
- Low current consumption by low power C-MOS technique: 3,6 V supply
- Temperature ranges: -40 to 85°C, -40 to 120°C
- External temperature sensor Type PT100, (Thermoelement type K Option)
- range programmable (optional internal temperature sensor)
- Accuracy: $\pm 1,5^{\circ}\text{C}$
- Max. acceleration: 500 g
- Size: 45 x 30 x 25 mm
- Optional -40 to +120°C environmental temperature
- Type: SV_8y_<channels>_<samplerate>_<temp>_mod_<sensor>

1	1	85	int
	10	120	ext

Dimensions

8 channel transmitter

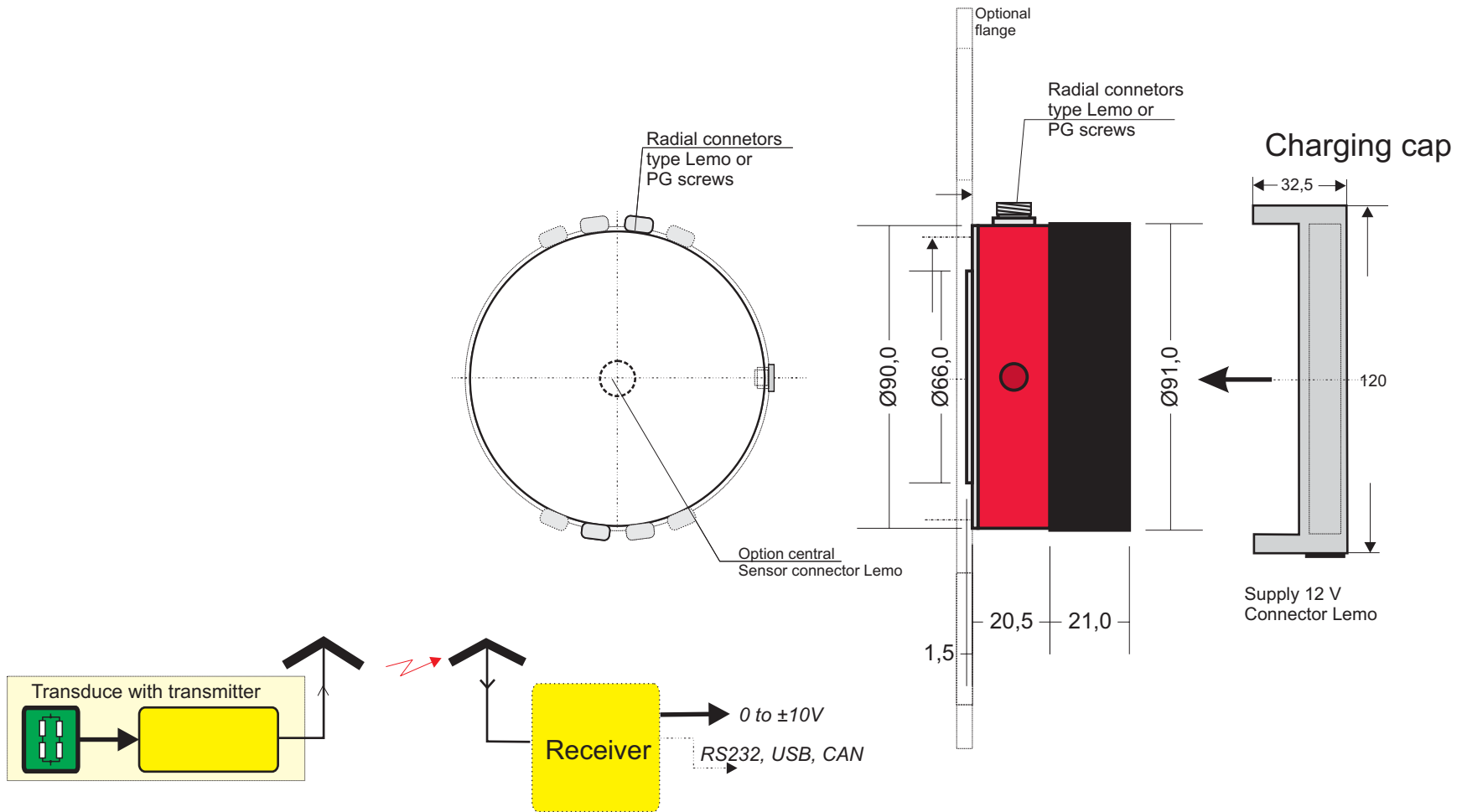

General Measurement Configuration for Multi Channel Systems

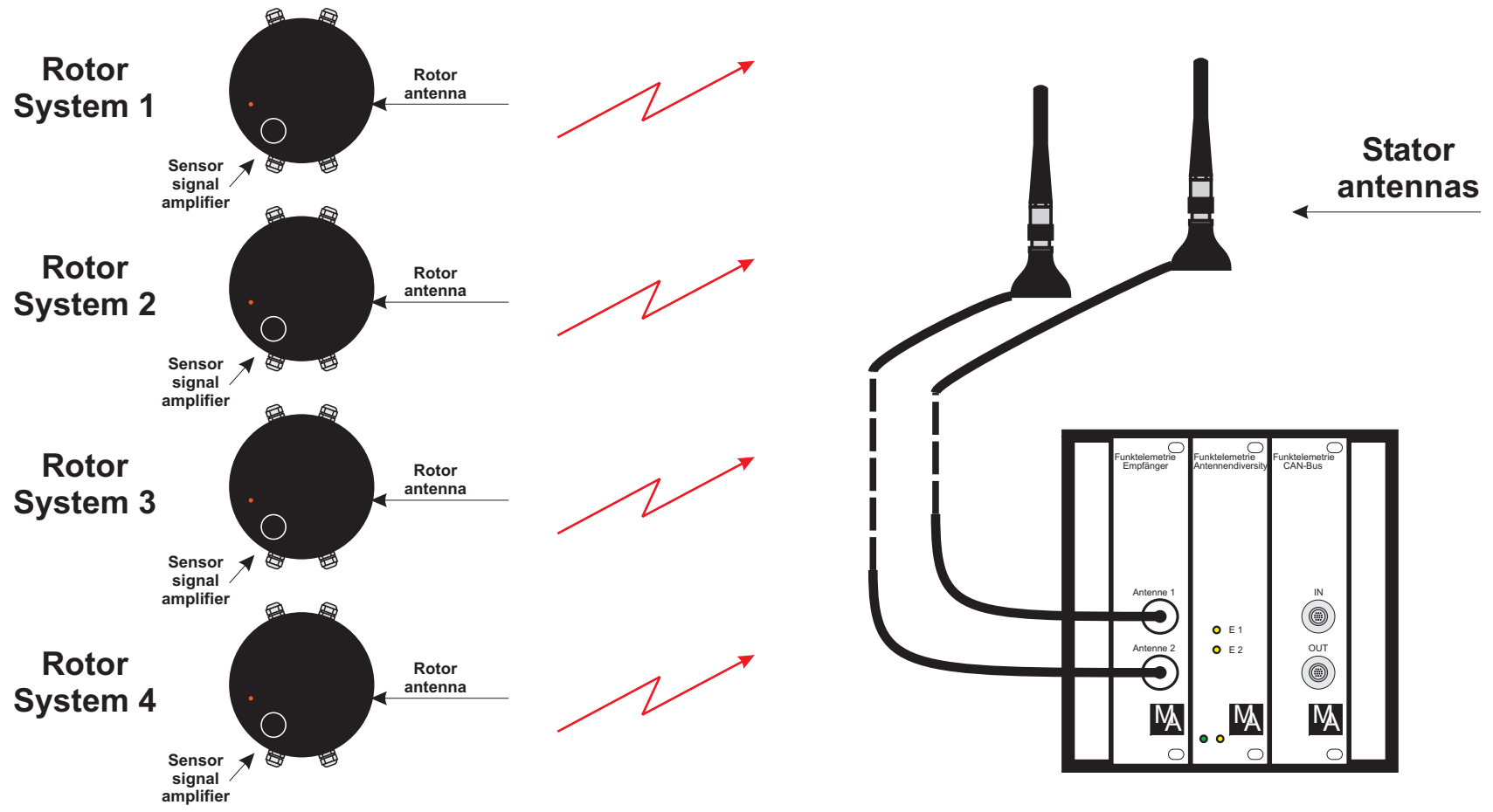

MANNER Radio Sensortelemetrie (point to point)

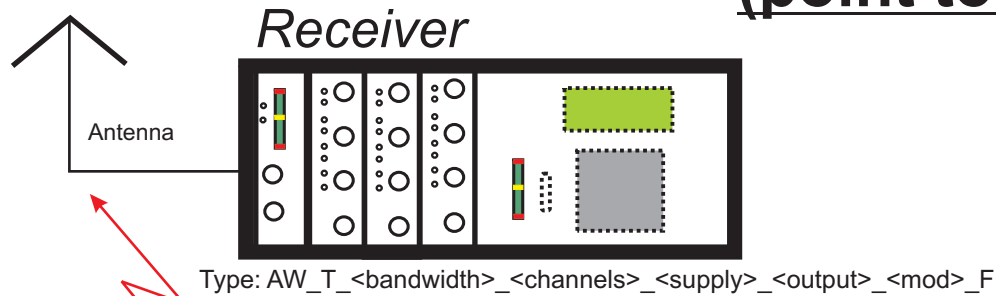

Up to 50 m

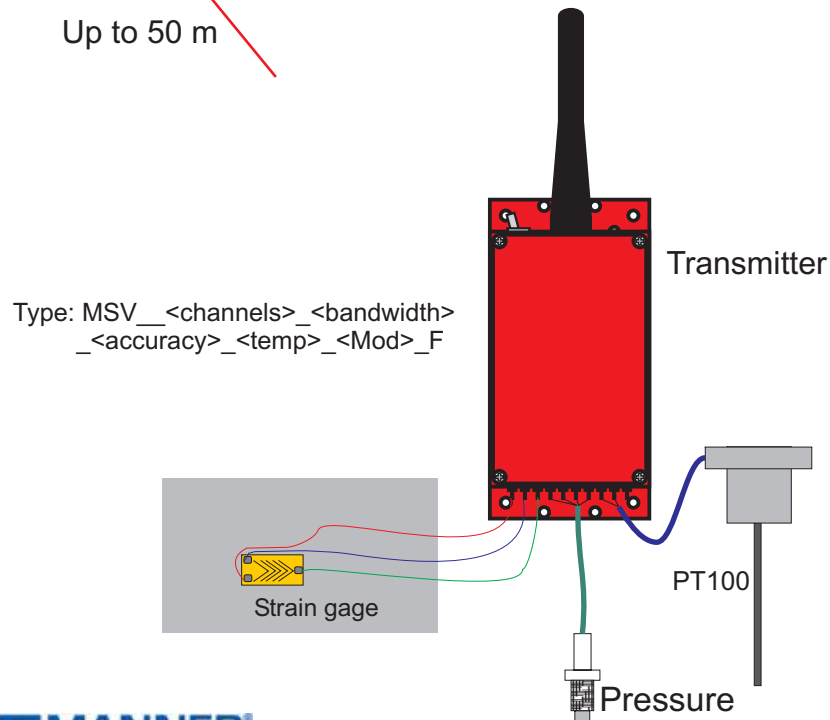
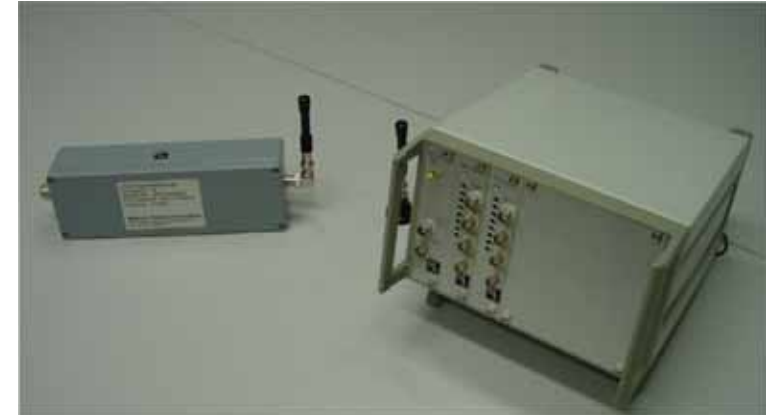

Features:

- Easy mounting
- with Accu-supply 3,6 V Lithium, max 35 hours (one cycle)
- Channel count: max. 16
- Sample rate: 40 000 Sample/s 1 channel)
- Sample rate: 2000/4000/8000 Sample/s /channel at 8 channels
- Digital transmitting 12/16 Bit resolution with checksum (CRC)
- Transmitting: Radio f = 433/868 MHz, 16 different frequencies
- RF-Power: 10 mW; range: 50 m in open terrain
- Integrated data protection by checksum 16 Bit CRC
- Low current consumption by low power C-MOS technique: 3,6 V supply
- Integrated transducer amplifier range: 0,1 mV/V to 20 mV/V
- Range adjustable by solderable resistors
- or optional electrical remote programmable range with 12 Bit resolution
- Transducer: Strain gage, full- / half bridge, Thermocouple type K
- Zero drift / Gain drift: 0,01 %/°C (0,003 %/°C optional)
- Optional inductive supply
- Max. acceleration: 1500 g
- Optional -40 to + 120°C environmental temperature

MANNER Radio Sensortelemetry special for Train Application with Antenna Diversity

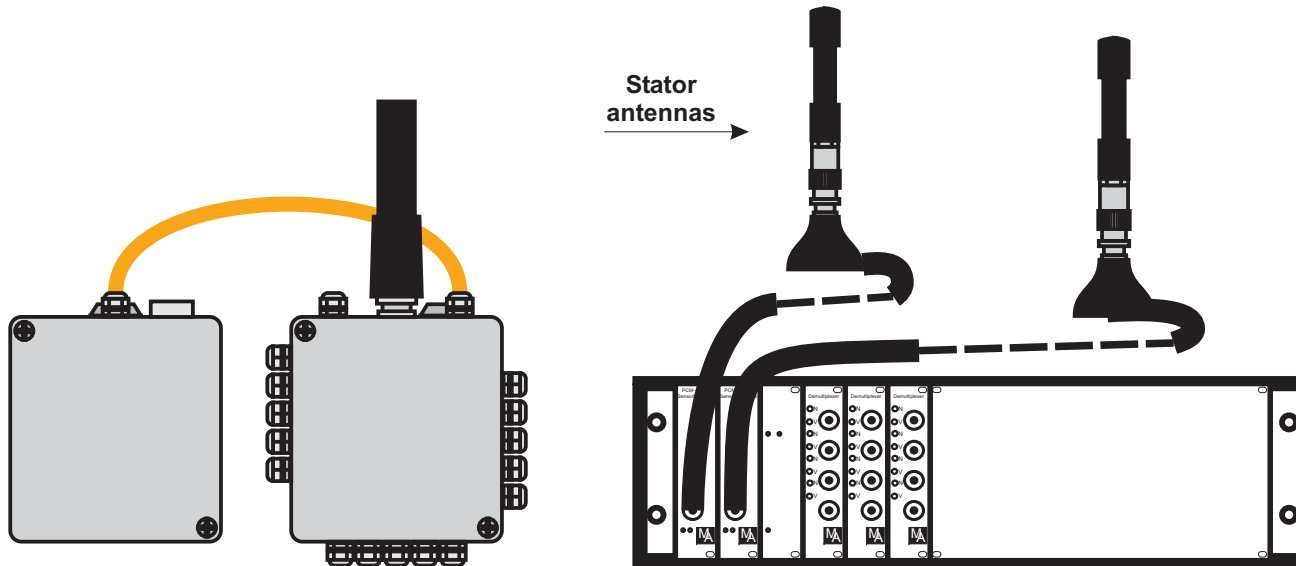

Features:

- Easy mounting
- with Accu-supply 3,6 V Lithium,
- Max 35 hours (one cycle)
- Channel count: 16 (max. 32)
- Sample rate: 4000 Sample/s (1 channel)
- Sample rate: 750 Sample/s at 16 ch.
- Digital transmitting 12/16 Bit resolution with checksum (CRC)
- Transmitting: Radio $f = 433/868$ MHz,
- 16 different frequencies
- RF-Power: 10 mW; range: 30 m
- integrated Data protection
- Antenna diversity for improved reception by checksum 16 Bit CRC
- Low current consumption by low power C-MOS technique: 3,6 V supply
- Integrated transducer amplifier range: 0,1 mV/V to 20 mV/V
- Electrical remote programmable range with 12 Bit resolution
- Transducer: Strain gage, full- / , half bridge, Thermocouple type K
- Zero drift / Gain drift: 0,01 %/°C
- Optional inductive supply
- Max. acceleration: 1500 g
- Temperature -40 to +85°C

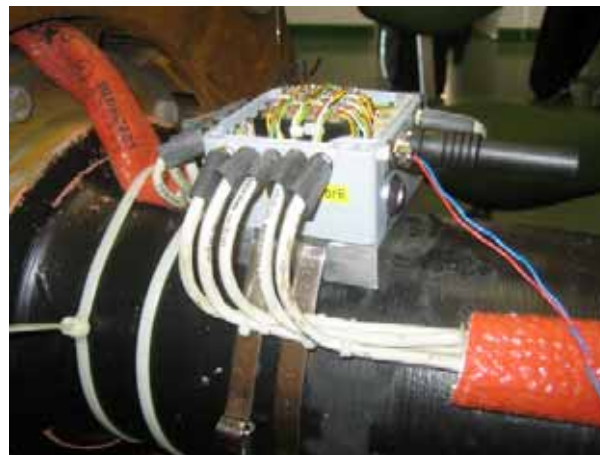

Multi Channel Radio Sensortelemetrie (separate frequencies)

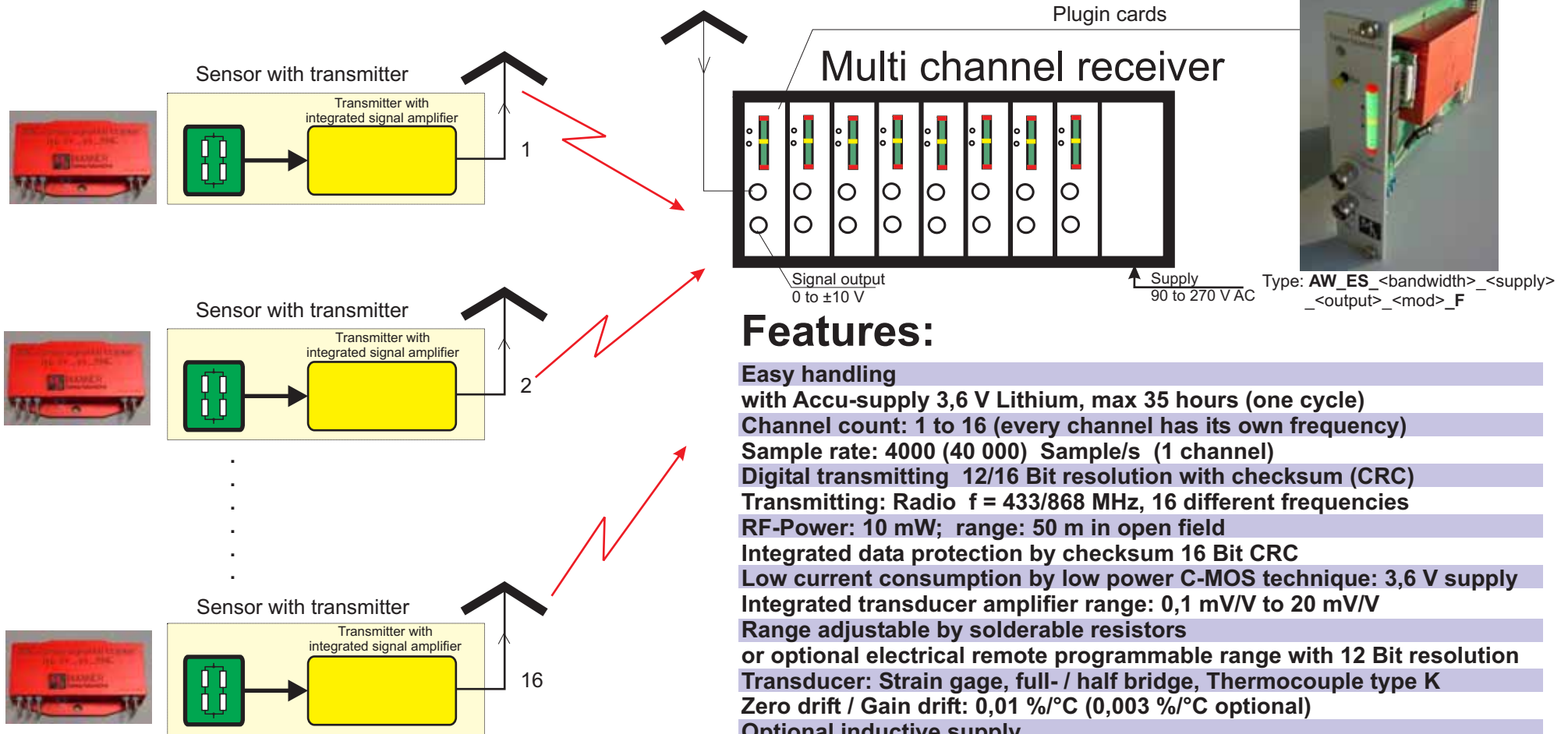

Type: SV_4_<bandwidth>_<accuracy>_<temp>_<mod>_F

Features:

- Easy handling**
- with Accu-supply 3,6 V Lithium, max 35 hours (one cycle)
- Channel count: 1 to 16 (every channel has its own frequency)
- Sample rate: 4000 (40 000) Sample/s (1 channel)
- Digital transmitting 12/16 Bit resolution with checksum (CRC)
- Transmitting: Radio f = 433/868 MHz, 16 different frequencies
- RF-Power: 10 mW; range: 50 m in open field
- Integrated data protection by checksum 16 Bit CRC
- Low current consumption by low power C-MOS technique: 3,6 V supply
- Integrated transducer amplifier range: 0,1 mV/V to 20 mV/V
- Range adjustable by solderable resistors
- or optional electrical remote programmable range with 12 Bit resolution
- Transducer: Strain gage, full- / half bridge, Thermocouple type K
- Zero drift / Gain drift: 0,01 %/°C (0,003 %/°C optional)
- Optional inductive supply
- Max. acceleration: 1500 g
- Temperature range: -10 to +85°C
- Optional -40 to +120°C environmental temperature

Multi Channel Radio Sensortelemetrie

(separate frequencies, point to point)

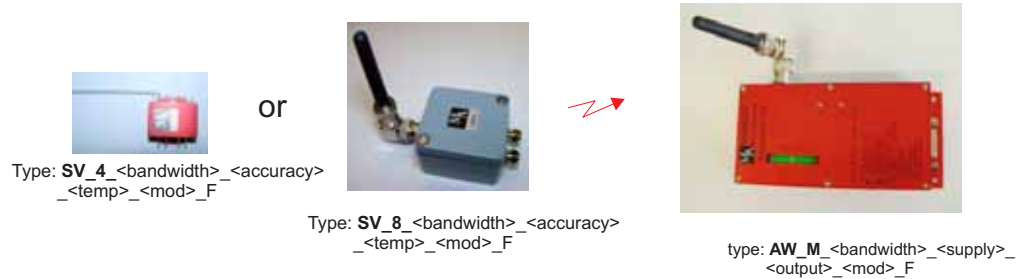
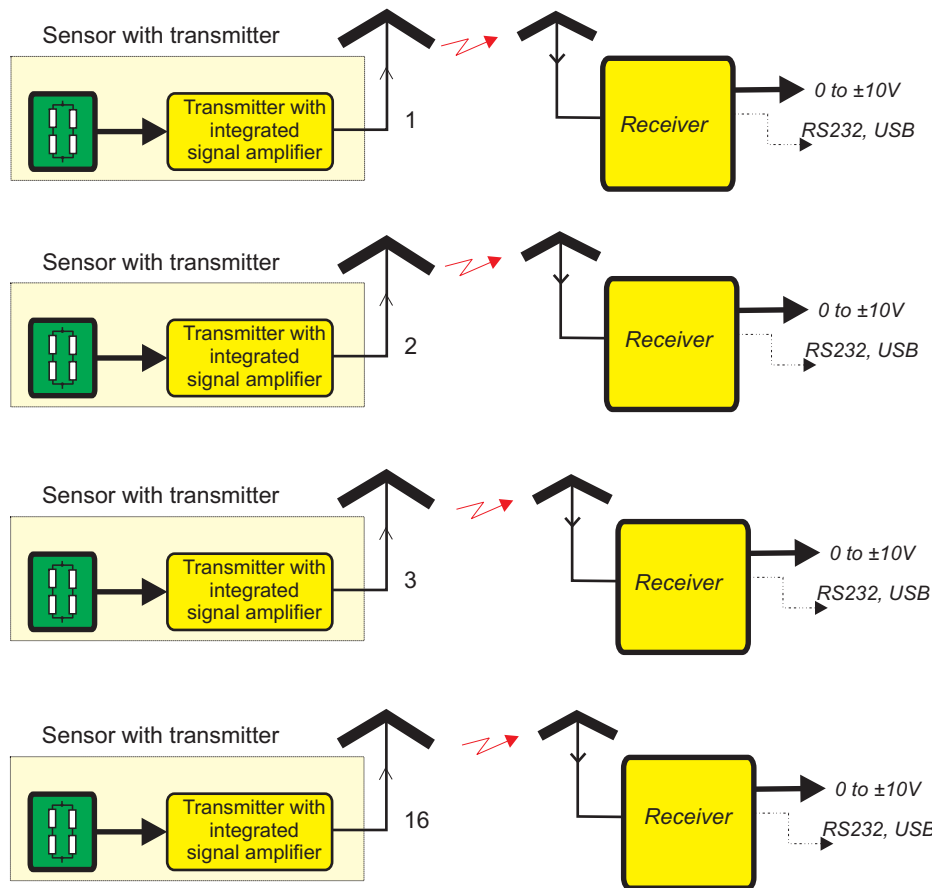

Features:

- Easy handling
- Channel count: 1
- (16 different frequencies)
- Sample rate: 4000 Sample/s (1 channel)
- Digital transmitting 12/16 Bit resolution with checksum (CRC)
- Transmitting: Radio $f = 433/868$ MHz, 16 different frequencies
- RF-Power: 10 mW; range: 50 m in open field
- Integrated data protection by checksum 16 Bit CRC
- Low current consumption by low power C-MOS technique: 3,6 V supply
- Integrated transducer amplifier range: 0,1 mV/V to 20 mV/V
- Range adjustable by solderable resistors
- or optional electrical remote programmable range with 12 Bit resolution
- Transducer: Strain gage, full- / half bridge, Thermocouple type K
- Zero drift / Gain drift: 0,01 %/°C (0,003 %/°C optional)
- Max. acceleration: 1500 g
- Temperature range: -10 to +85°C
- Optional -40 to +120°C environmental temperature
- with Accu-supply 3,6 V Lithium, max 35 hours (one cycle)

Multi Channel Radio Sensortelemetrie

(multiplex mode, one frequency, multi point to point, low speed application)

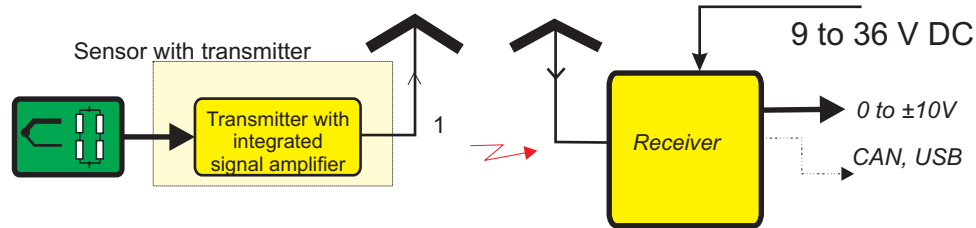

Type: AW_M_<bandwidth>_<supply>_<output>_<mod>_F

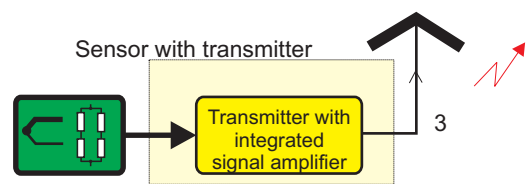
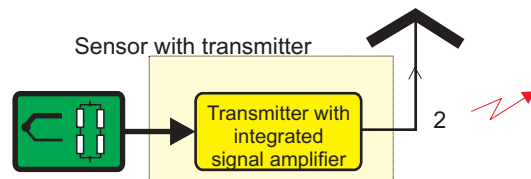

Type: SV_8_<bandwidth>_<accuracy>_<temp>_<mod>_F

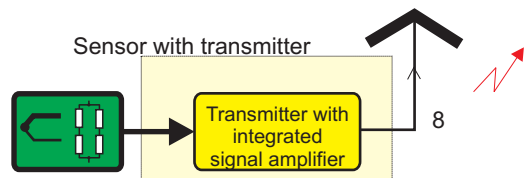

Features:

- Easy handling
- Multichannel (time multiplex)
- Channel count (max): 8
- (16 different frequencies)
- Sample rate: 10 Sample/s/channel
- Digital transmitting 12/16 Bit resolution with checksum (CRC)
- Transmitting: Radio f = 433/868 MHz, 16 different frequencies
- RF-Power: 10 mW; range: 50 m in open field
- Integrated data protection by checksum 16 Bit CRC
- Integrated transducer amplifier range: 0,1 mV/V to 20 mV/V
- Range adjustable by solderable resistors
- or optional electrical remote programmable range with 12 Bit resolution
- Transducer: Strain gage, full- / half bridge, Thermocouple type K
- Zero drift / Gain drift: 0,01 %/°C (0,003 %/°C optional)
- Max. acceleration: 1500 g
- Temperature range: -10 to +85°C
- Optional -40 to +120°C environmental temperature
- Low power mode, low power C-MOS technique: 3,6 V supply
- with Accu-supply 3,6 V Lithium, max 150 hours (one cycle)

Option Radio Sensortelemetrie with Antenna Diversity

(Security improvement of data transmission by use of 2 antennas)

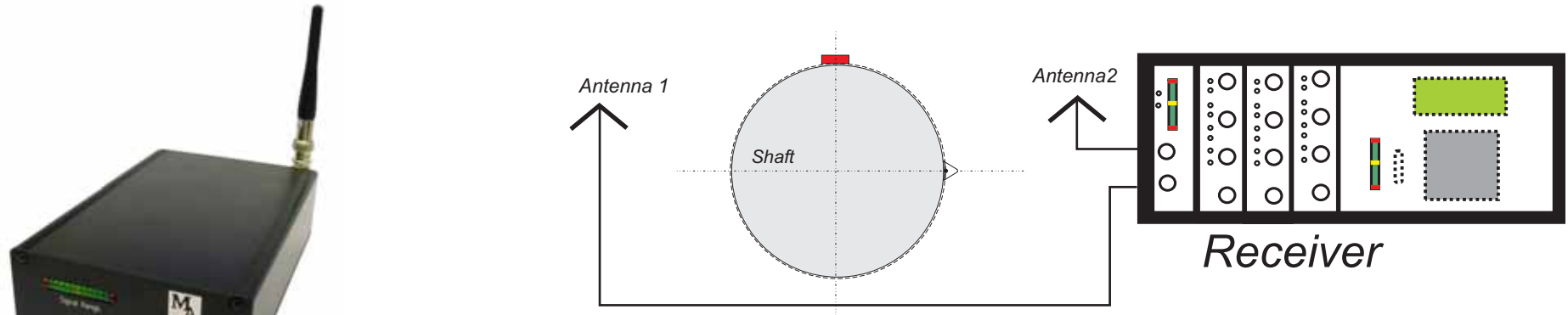

Features:

- Up to thousandfold improvement of reception in case of interferences
 - 2 receiver systems with 2 separate antennas
 - Diversity combiner selects every time the best signal
 - Avoiding of lost of sensor data in case of bad reception or interferences
 - Digital transmitting 12/16 Bit resolution with checksum (CRC)
 - Transmitting: Radio $f = 433..2,4$ GHz
 - RF-Power: 10 mW; range: 50 m in open terrain
 - Integrated data protection by checksum 16 Bit CRC
 - Special for large shafts
 - Special for train application
 - Special for hard reception conditions
 - Div_<channels>_<receivers>
- | | |
|--------|------|
| 1..128 | 2..6 |
|--------|------|

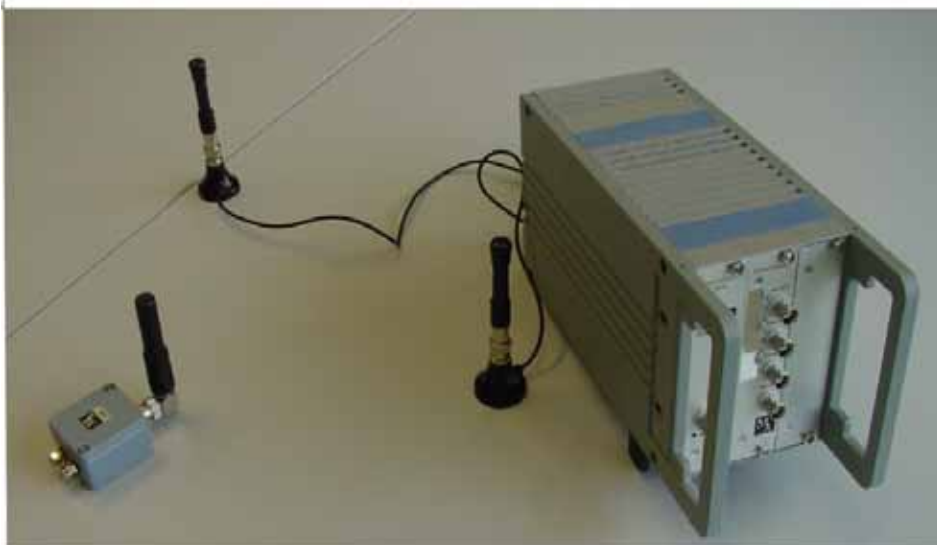

Option RMC Sensor Telemetry

For initial remote setup of the of strain gage application at installation

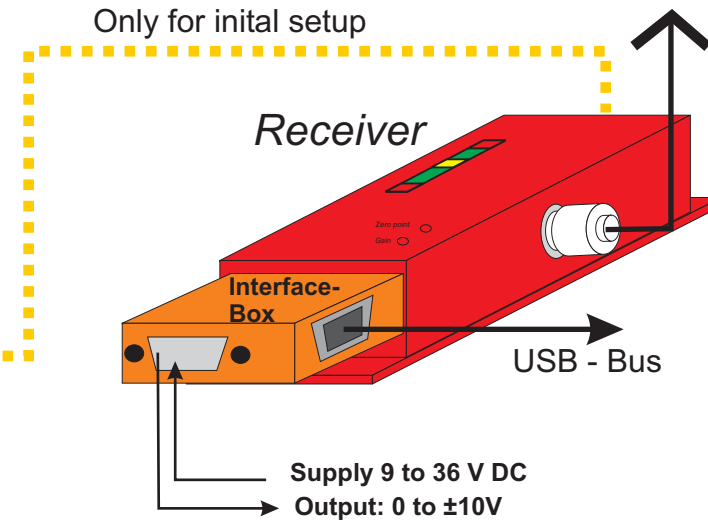

*Auto zero,
Adjusting tolerances in zero point
Adjusting tolerances in gain*

*Remote online re-conditioning
without opening of the
amplifier*

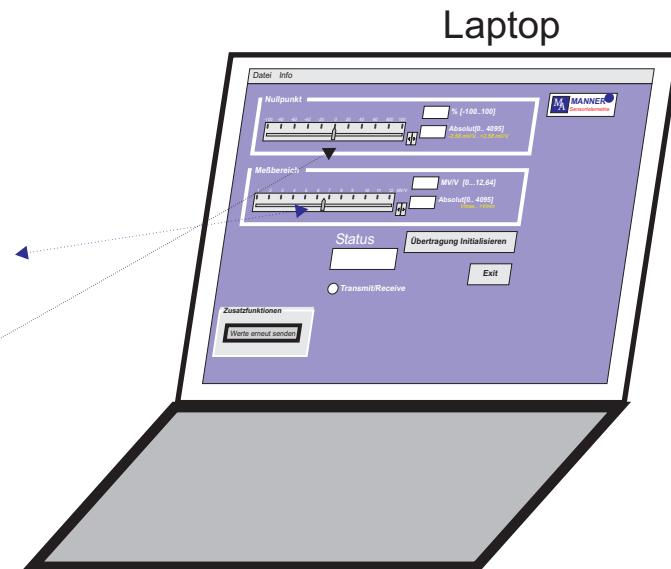
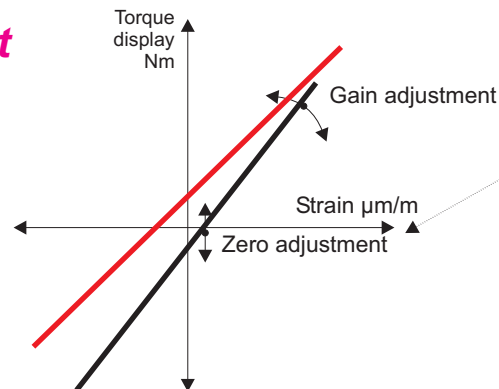

Remote programmable Sensor Telemetry

High resolution (12 Bit) initial remote setup of the strain gage application at installation and calibration

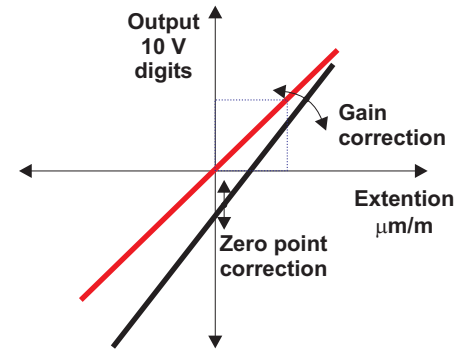

Separate address for each amplifier

gain, zero adjustable with 12 bits resolution (internal storage)

RMC Sensortelemetry

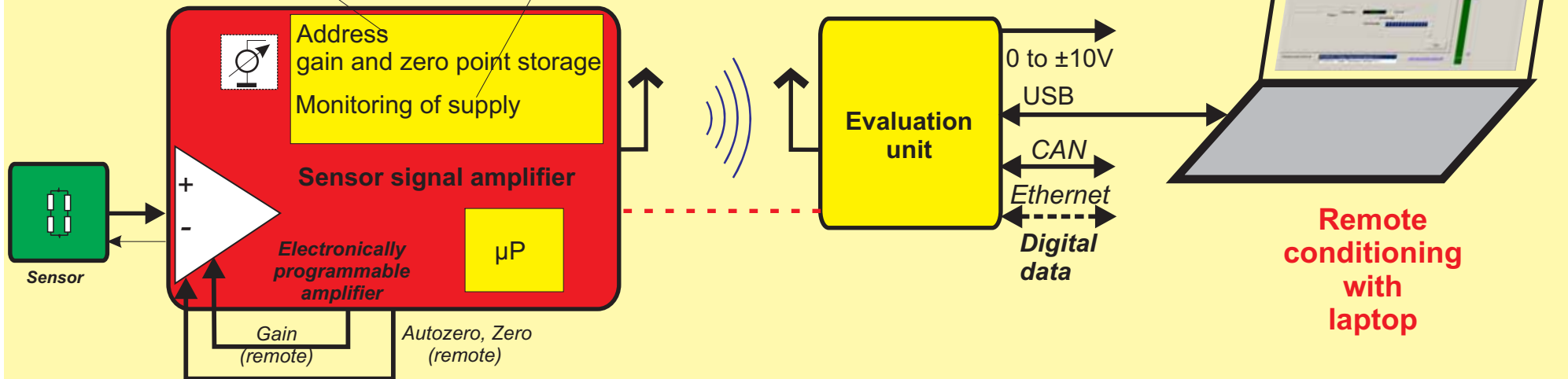

How does RMC Sensor Telemetry work?

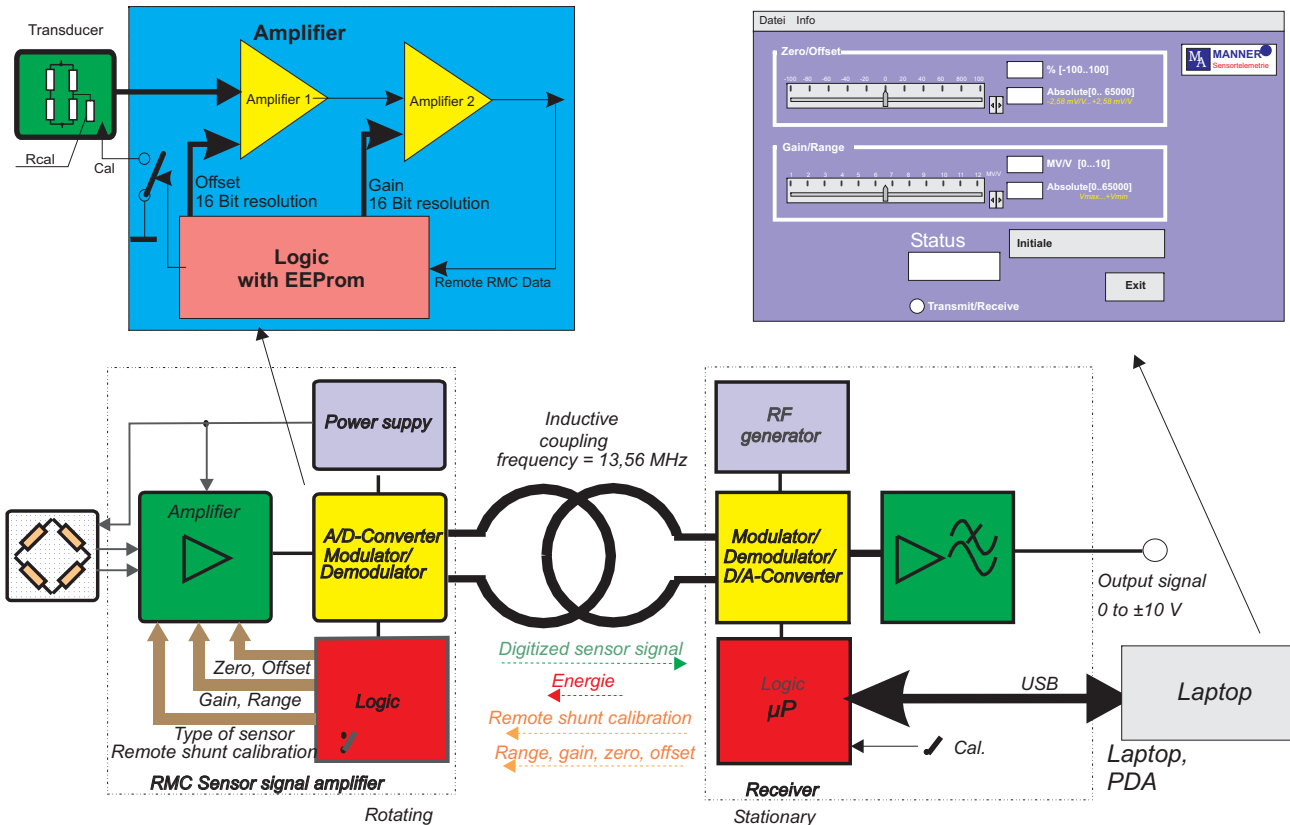

Features:

- * Remote high resolution adjustment (16 Bit) of gain, range (0,05 to 10 mV/V)
- * Auto zero
- * Remote high resolution adjustment (16 Bit) of zero, offset ($\pm 500\%$ from the adjusted range)
- * Digitizing of sensor signal with 16 Bit resolution inside the sensor signal amplifier
- * Integrated sensor signal amplifier for direct interface of strain gage:
Standard: strain gage, PT100
Option: Thermocouple, piezo electric, ICP, LVDT
- * Remote shunt calibration (option)
- * Integrated power supply for transducer and amplifier
- * Very small zero/gain drift: 0,003 %/°C
- * Very good linearity: <0,003 %
- * Environment temperature: -25 to +125°C (-45 to +120°C option)
- * Protection: IP67
- * Integrated speed sensor (option)
- * Serial interface USB, direct control of gain and auto zero by laptop, PDA

The control data for gain and zero will be online transferred via the telemetry channel

Radio-Sensortelemetry Components

Sensor Signal Amplifier Type 2 End of Shaft

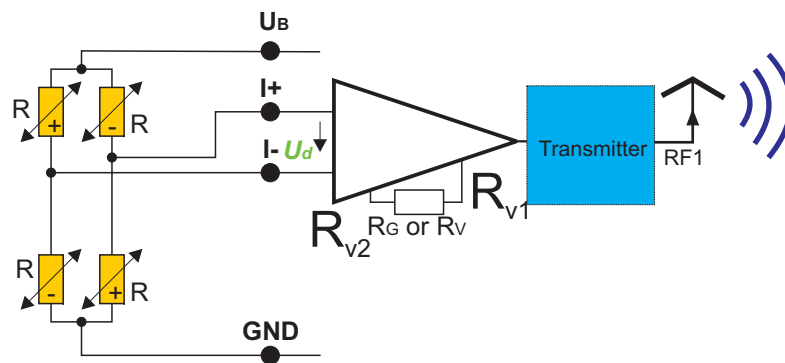
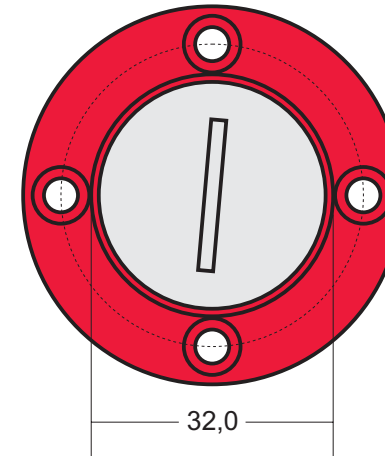
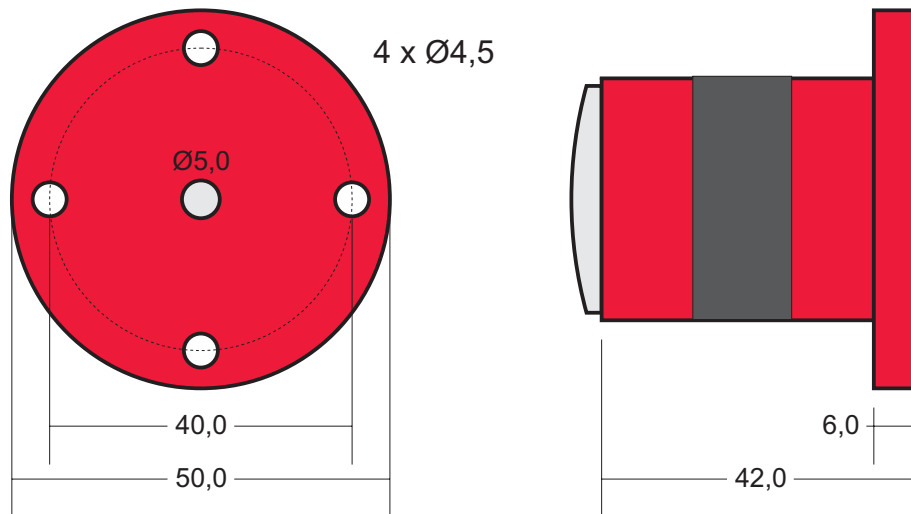

1 Channel Radio Sensortelemetry transmitter

For strain gage, PT100, Thermocouple

Sensitivity: 0,02 to 20 mV/V

Bandwidth (10 Hz / 0 Hz to 1 kHz

Bridge supply: 3 V

Strain gage: 350 Ω

Transmission: Radio Sensortelemetry PCM

Integrated filter

Resolution: 14 Bit (16 Bit)

Drift zero: 0,02 (0,01, 0,005 option)

Supply: 3,3 to 12 V, 50 mA

Remote range control, auto zero (option)

Environmental temperature: -25 to +85°C (120°C)

Max load: 1 000 g (depends on fixing)

Type: SV_2_<accuracy>_<temp>_Fu_<mod>_<bandwidth>_<rmc>_<TC>

1 kHz	0,02	85	PCM12	-	-
	0,01	120	PCM16	RC	TC
	0,005				

Sensor Signal Amplifier Type 4a

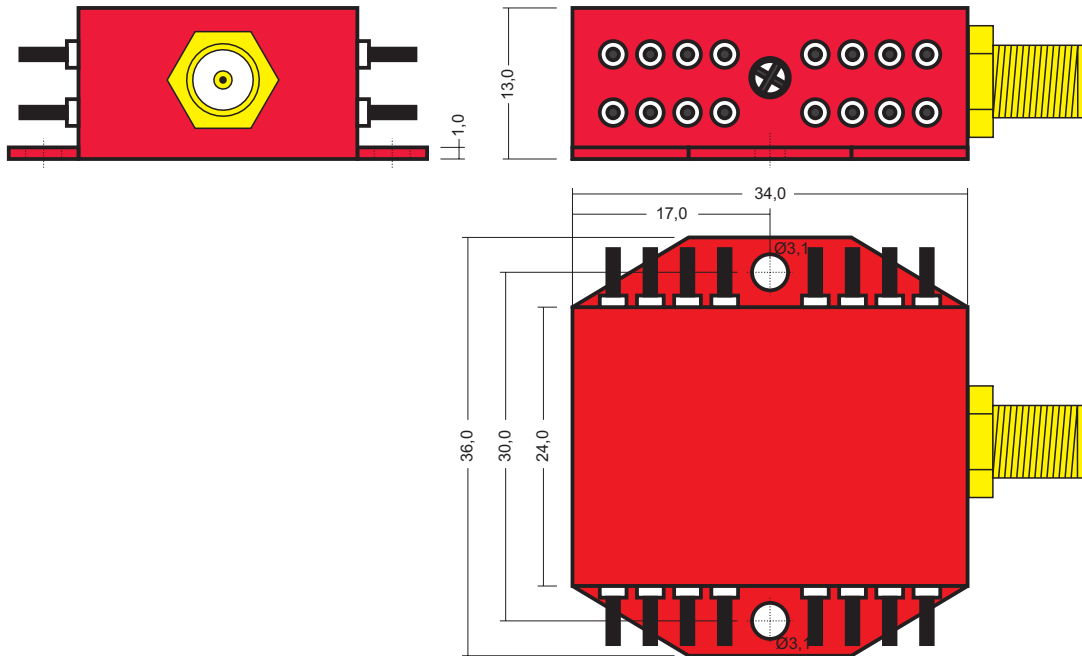

Weight: about 12g

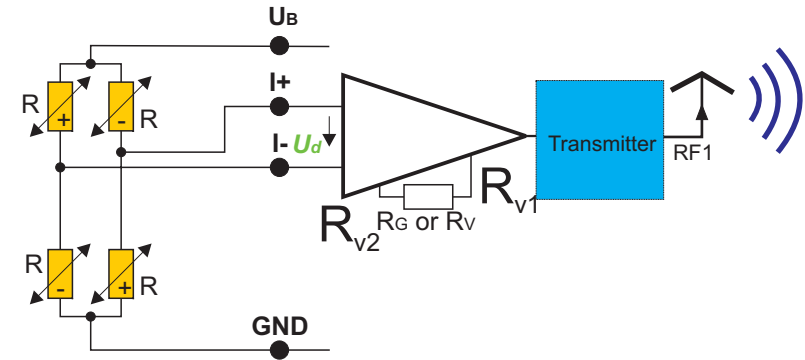

1 Channel Radio Sensortelemetry transmitter

For strain gage, PT100, Thermocouple

Sensitivity: 0,02 to 20 mV/V

Bandwidth 10 Hz / 0 Hz to 1 kHz

Bridge supply: 3 V

Strain gage: 350 Ω

Transmission: Radio Sensortelemetry PCM

Integrated filter

Resolution: 14 Bit (16 Bit)

Drift zero: 0,02 (0,01, 0,005 option)

Supply: 3,3 to 12 V, 50 mA

Remote range control, auto zero (option)

Environmental temperature: -25 to +85°C (120°C)

Max load: 1 000 g (depends on fixing)

Type: SV_4a_<accuracy>_<temp>_Fu_<mod>_<bandwidth>_<rmc>_<TC>

0,02	85	PCM12	1 kHz	-	-
0,01	120	PCM16	2 kHz	RC	TC
0,005					

Sensor Signal Amplifier Type 2b (End of shaft, Cartridge, Turbine)

integrated antenna

Weight: about 13g

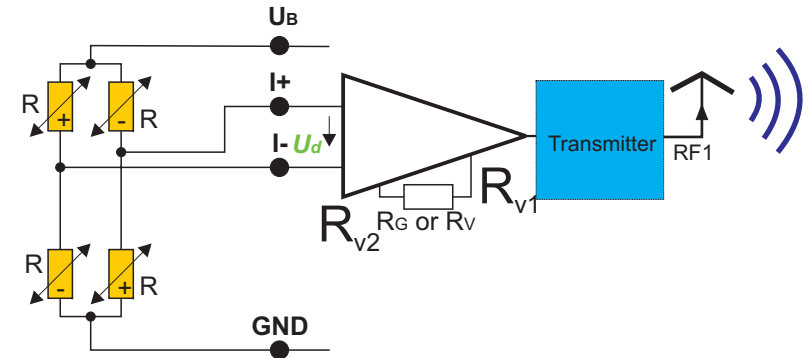
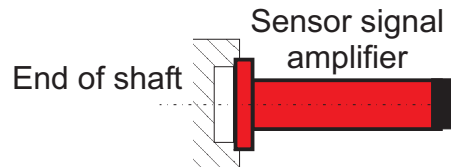
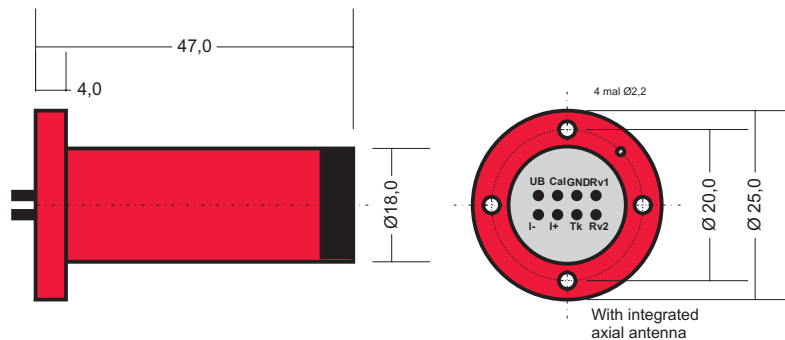

1 Channel Radio Sensortelemetry transmitter

For strain gage, PT100, Thermocouple

Sensitivity: 0,02 to 20 mV/V

Bandwidth 10 Hz / 0 Hz to 1 kHz

Bridge supply: 3 V

Strain gage: 350 Ω

Transmission: Radio Sensortelemetry PCM integrated antenna

Integrated filter

Resolution: 14 Bit (16 Bit)

Drift zero: 0,02 (0,01, 0,005 option)

Supply: 3,3 to 12 V, 50 mA

Remote range control, auto zero (option)

Environmental temperature: -25 to +85°C (120°C)

Max load: 1 000 g (depends on fixing)

Type: SV_4b_<accuracy>_<temp>_Fu_<mod>_<bandwidth>_<rmc>_<TC>

0,02	85	PCM12	1 kHz	-	-
0,01	120	PCM16	2 kHz	RC	TC
0,005					

Sensor Signal Amplifier Type SV_Rad

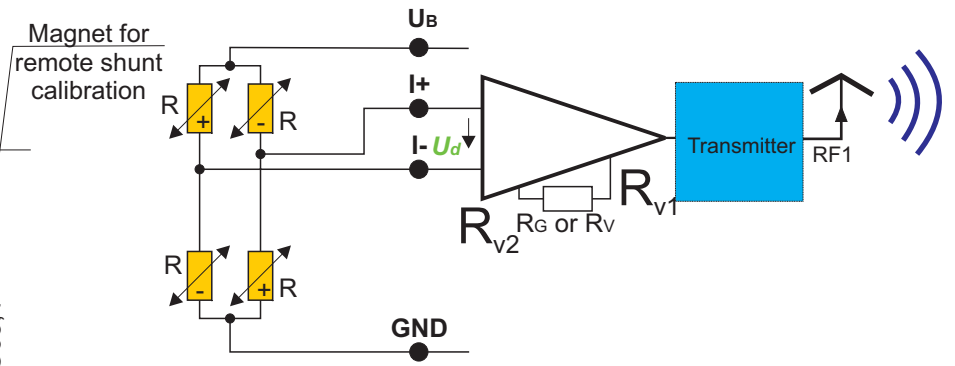
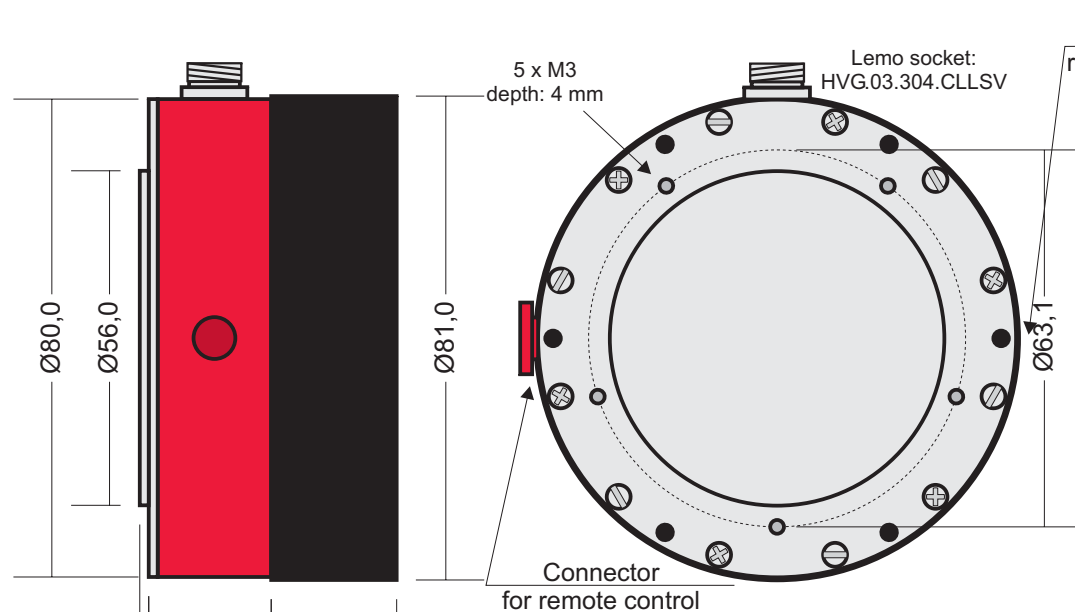

1 Channel Radio Sensortelemetry transmitter for wheels or shaft end applications

- For strain gage, PT100, Thermocouple
- Sensitivity: 0,02 to 20 mV/V
- Bandwidth 10 Hz / 0 Hz to 1 kHz
- Bridge supply: 3 V, Accu rechargeable
- Strain gages: 350 Ω
- Transmission: Radio Sensortelemetry PCM
- Diameter: 80 mm, height: 43 mm
- Resolution: 12 Bit (16 Bit)
- Drift zero: 0,02 (0,01, 0,005 option)
- Recharging by inductive recharging cap (contactless)
- Operating time between recharging: 30 hours
- Activating by switch
- Remote range control, auto zero (option)
- Environmental temperature: -25 to +85°C (120°C)
- Protection: IP67

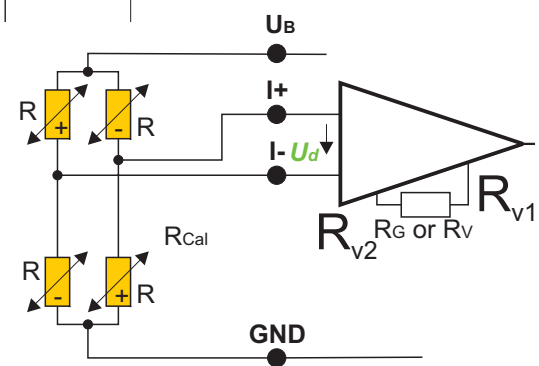

Max load: 1 000 g (depends on fixing)

Type: SV_Rad <accuracy> <temp> Fu <mod> <bandwidth> <rmc> <TC>

0,02	85	PCM12	1 kHz	-	-
0,01	120	PCM16		RC	TC
0,005					

Sensor Signal Amplifier Type 8a (waterproof)

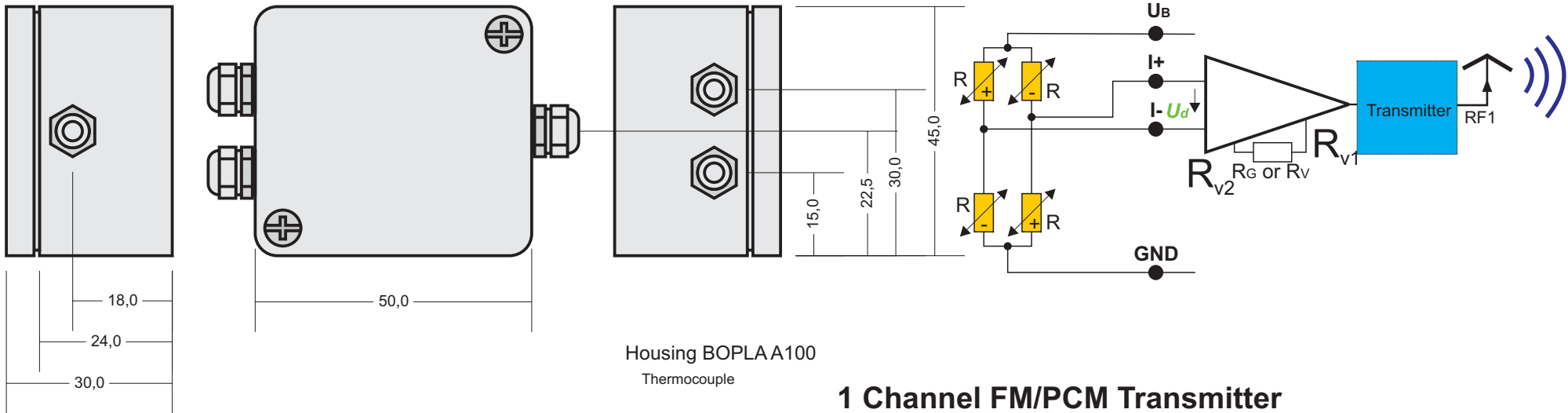

* PCM-Version

1 Channel FM/PCM Transmitter

- For strain gage, PT100, Thermocouple
- Sensitivity: 0,02 mV/V to 20 mV/V
- Bandwidth: 0 (10) Hz to 50 kHz
- Strain gage bridge supply: 6 V (3,3 V*)
- Strain gage bridge resistance: 1000 Ω
- Transmission: inductive sensortelemetry FM, PCM
- Integrated filter
- Resolution: 14 Bits, 16 Bits*
- Zero point drift: 0,02, (0,01, 0,003* option)
- Remote shunt calibration
- Remote gain, zero, auto zero with 16 Bit resolution (option)
- additional temperature channel (option)
- Environmental temperature range: -25 to +85°C (125°C, 150°C)
- Max load: 50 000 g (depending on fixing)
- Type: SV_8a_<accuracy>_<temp>_Fu_<mod>_<bandwidth>_<rmc>_wa_<TC>

0,02	85	FM	1 kHz	-	-
0,01	125	PCM16	10 kHz	RMC	TC
0,003	150		40 kHz		

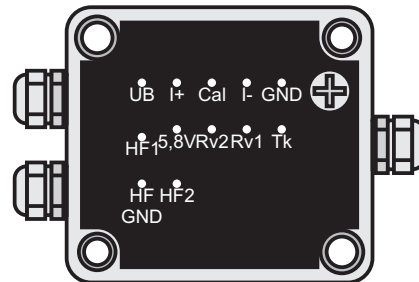

Sensor Signal Amplifier Type 8b

special for tension belt fixing (waterproof)

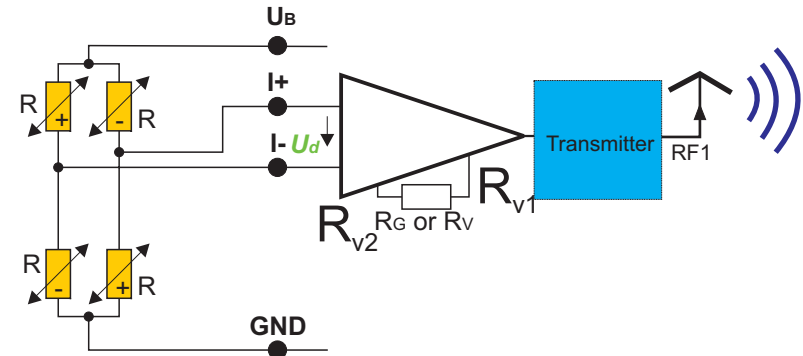
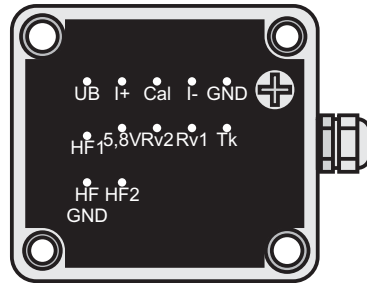
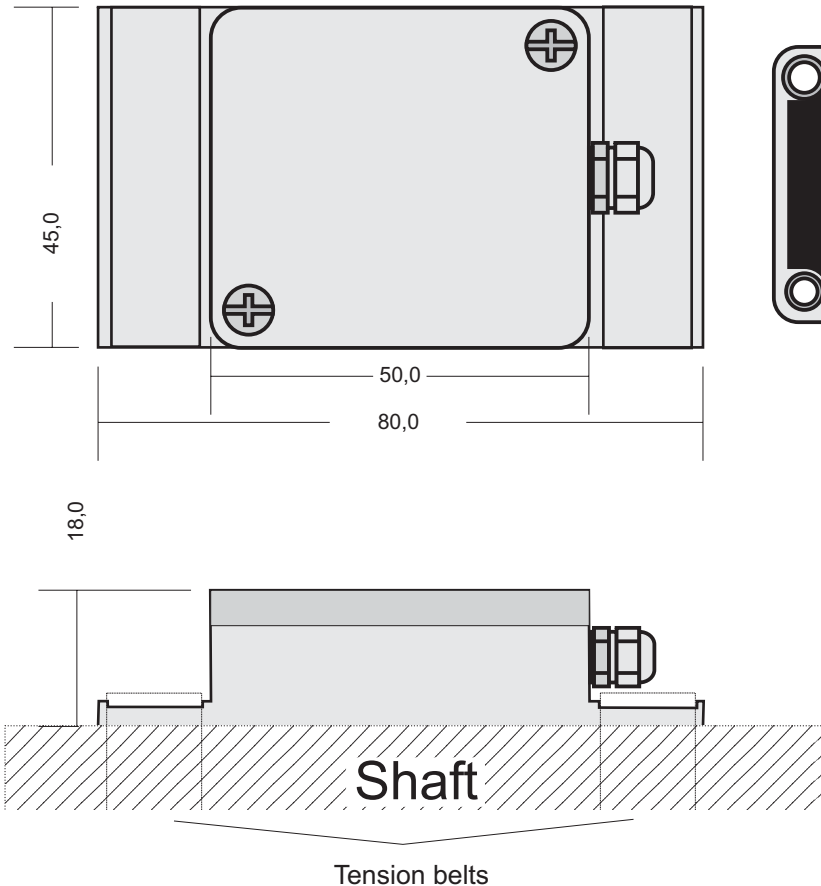

1 Channel Radio Sensortelemetry transmitter with integrated transmitting antenna and accu pack

- For strain gage, PT100, Thermocouple
- Sensitivity: 0,02 to 20 mV/V
- Bandwidth 10 Hz / 0 Hz to 1 kHz
- Bridge supply: 3 V
- Strain gages: 350 Ω
- Transmission: Radio Sensortelemetry PCM
- Integrated filter
- Resolution: 14 Bit (16 Bit)
- Drift zero: 0,02 (0,01, 0,005 option)
- Supply: 3,3 to 12 V, 50 mA,
- operating with 1 accu charge 30 hours
- Remote range control, auto zero (option)
- Environmental temperature: -25 to +85°C (120°C)
- protection: IP65
- Max load: 1 000 g (depends on fixing)
- Type: SV_8b_<accuracy>_<temp>_Fu_<mod>_<bandwidth>_<rmc>_wa_<TC>

0,02	85	PCM12	1 kHz	-	-
0,01	120	PCM16		RMC	TC
0,005					

Sensor Signal Amplifier Type 9

Through hole
 $\varnothing = 7\text{mm}$ for weight reduction

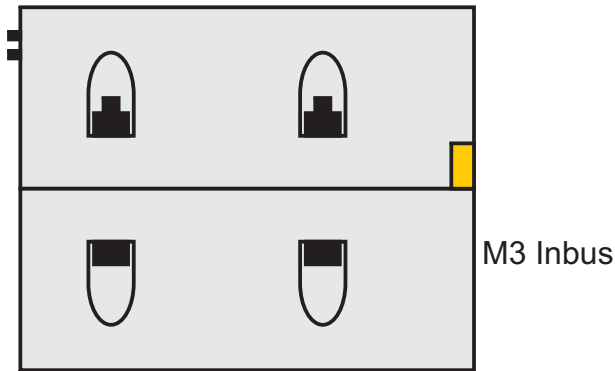

Inner diameter: 17 to 50mm
 Outer diameter = Inner diameter + 20mm

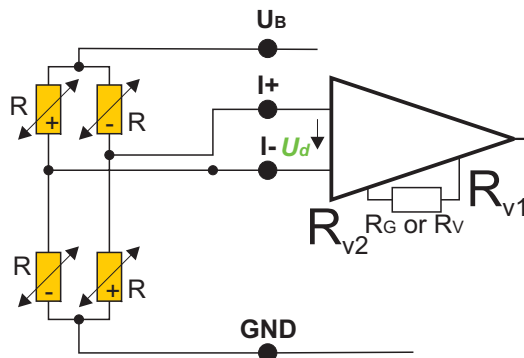
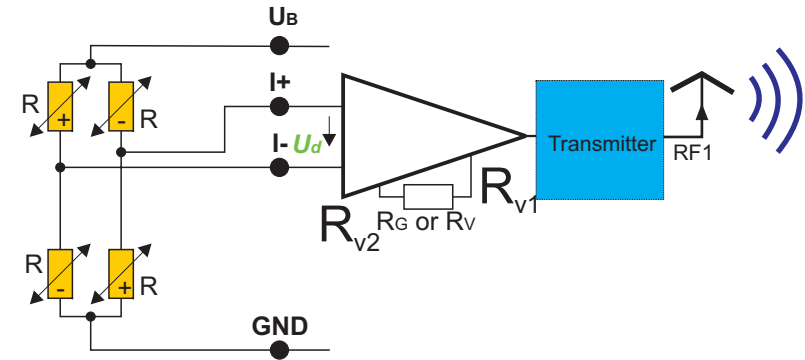
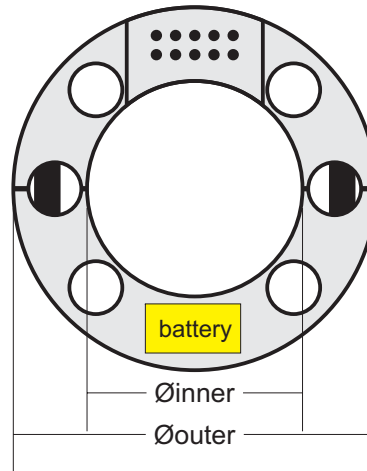

1 Channel Radio Sensortelemetry transmitter

- For strain gage, PT100, Thermocouple
 - Sensitivity: 0,02 to 20 mV/V
 - Bandwidth 10 Hz / 0 Hz to 1 kHz
 - Bridge supply: 3 V
 - Strain gages: 350 Ω
 - Transmission: Radio Sensortelemetry PCM
 - Integrated filter
 - Resolution: 14 Bit (16 Bit)
 - Drift zero: 0,02 (0,01, 0,005 option)
 - Supply: 3,3 to 12 V, 50 mA
 - Remote range control, auto zero (option)
 - Environmental temperature: -25 to +85°C (120°C)
 - Max load: 1 000 g (depends on fixing)
 - Type: SV_9_<accuracy>_<temp>_Fu_<mod>_<bandwidth>_<rmc>_<TC>
- | | | | | | |
|-------|-------|-----|-------|-----|----|
| 1 kHz | 0,02 | 85 | PCM12 | - | - |
| | 0,01 | 120 | PCM16 | RMC | TC |
| | 0,005 | | | | |

Multi channel signal Amplifier Type M waterproof

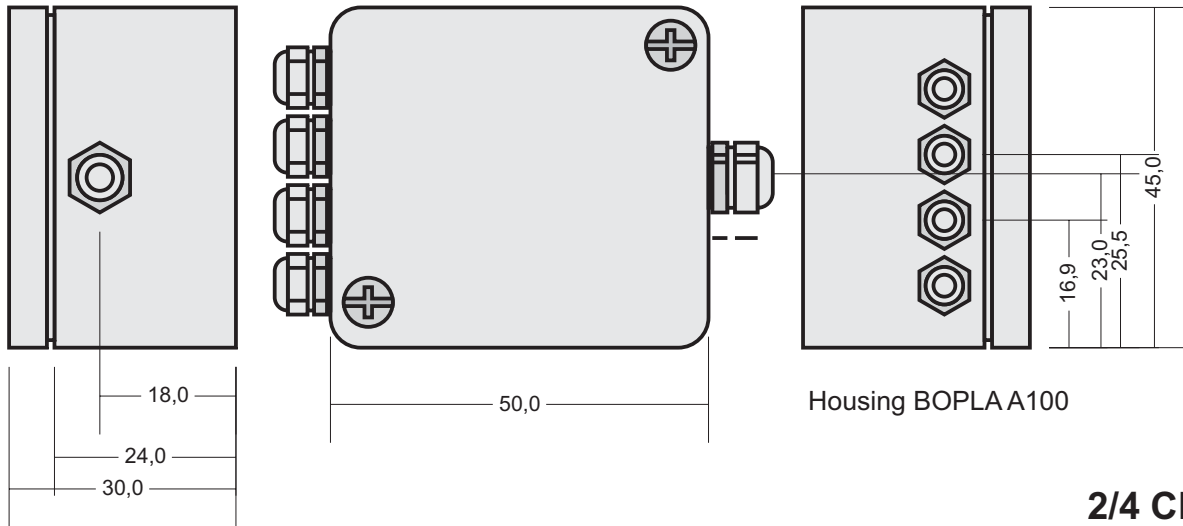

Housing BOPLA A100

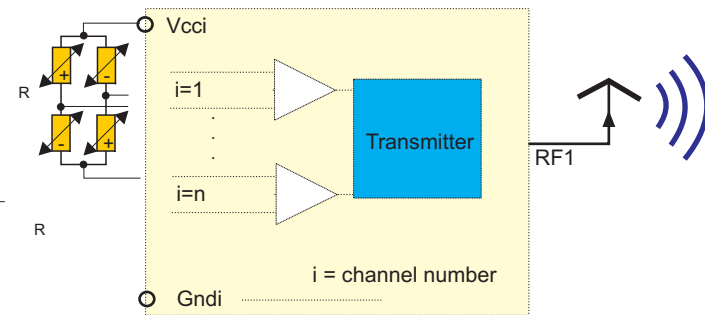

2/4 Channel Radio Sensortelemetry transmitter

- For strain gage, PT100, Thermocouple
- Sensitivity: 0,02 to 20 mV/V
- Bandwidth 10 Hz / 0 Hz to 10 kHz
- Brigde supply: 3 V
- Strain gages: 350 Ω
- Transmission: Radio Sensortelemetry PCM
- Integrated filter
- Resolution: 12 Bit (16 Bit)
- Drift zero: 0,02 (0,01, 0,005 option)
- Supply: 3,3 to 12 V, 50 mA
- Remote range control, auto zero (option)
- Environmental temperature: -25 to +85°C (120°C)
- Max load: 1 000 g (depends on fixing)
- Type: MSV_M_<channels>_<accuracy>_<temp>_Fu_<mod>_<sample>_<rmc>_wa_<TC>

2	0,02	85	PCM12	500	-	-
4	0,01	120	PCM16	4000	RMC	TC
8	0,005	150		8000		
16				40000		

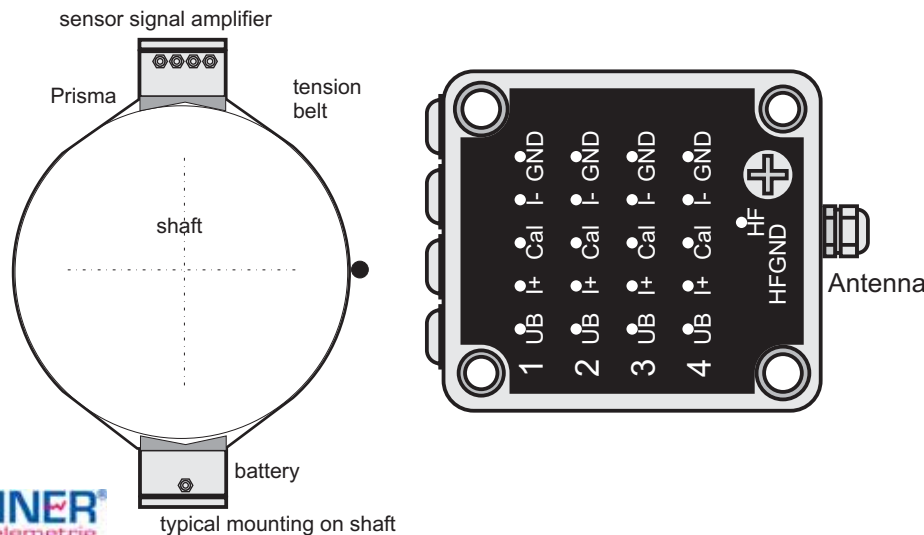

4/8 Channel Sensor Signal Amplifier Type M

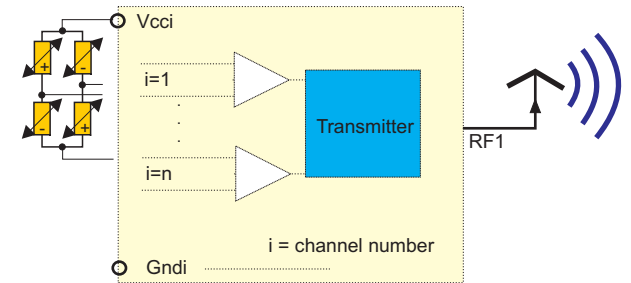
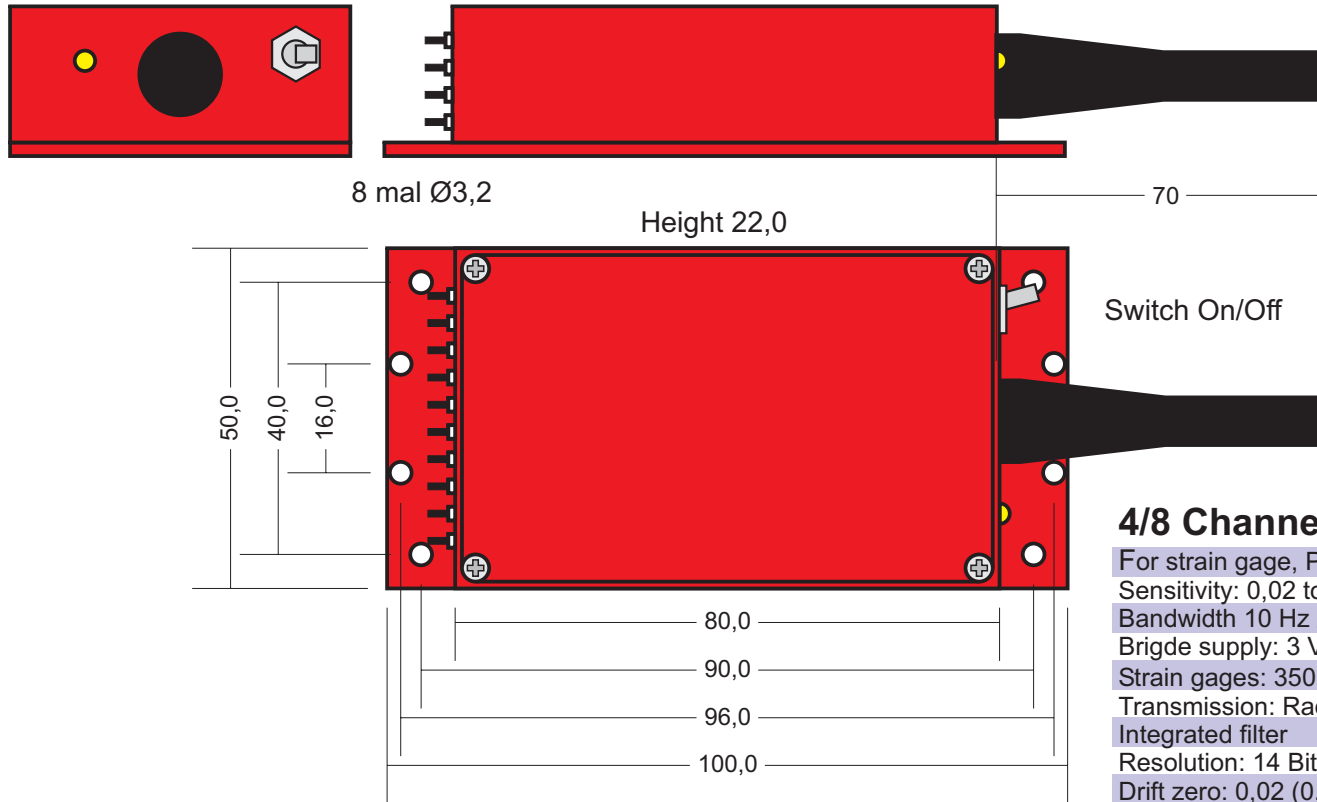

4/8 Channel Radio Sensortelemetry transmitter

For strain gage, PT100, Thermocouple

Sensitivity: 0,02 to 20 mV/V

Bandwidth 10 Hz / 0 Hz to 1 kHz

Bridge supply: 3 V

Strain gages: 350 Ω

Transmission: Radio Sensortelemetry PCM

Integrated filter

Resolution: 14 Bit (16 Bit)

Drift zero: 0,02 (0,01, 0,005 option)

Supply: 3,3 to 12 V, 50 mA

Remote range control, auto zero (option)

Environmental temperature: -25 to +85°C (120°C)

Max load: 1 000 g (depends on fixing)

Type: MSV_M_<channels>_<accuracy>_<temp>_Fu_<mod>_<sample>_<rmc>_<TC>

2	0,02	85	PCM12	500	-	-
4	0,01	120	PCM16	4000	RMC	TC
8	0,005	150		8000		
				40000		

Supply voltage supervision

LED on --> supply voltage $\geq 3,6$ V

LED off --> supply voltage $< 3,6$ V

4/8 Channel Sensor Signal Amplifier Type M_wa (waterproof, IP65)

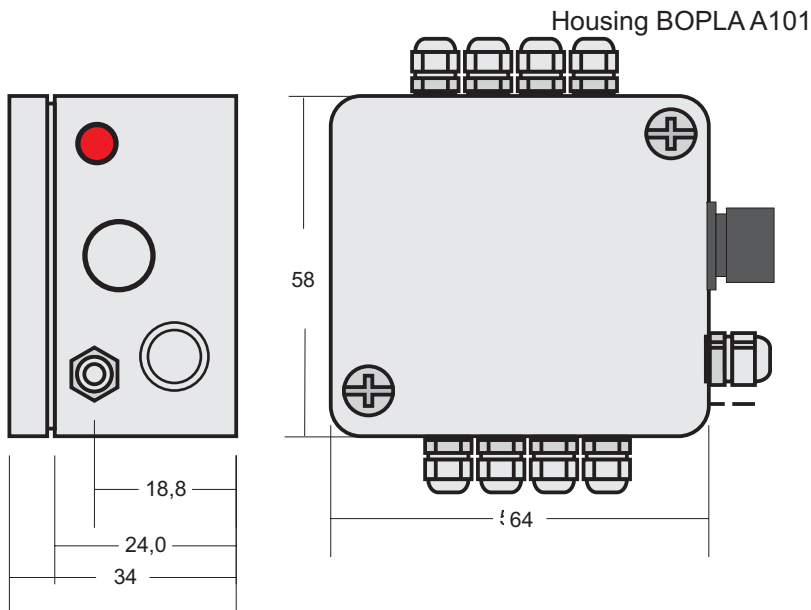
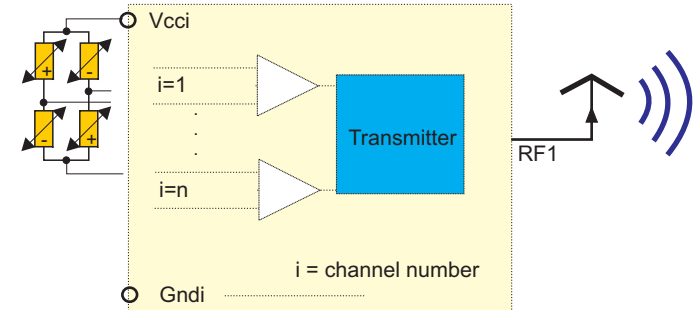

4/8 Channel Radio Sensortelemetry transmitter

- For strain gage, PT100, Thermocouple
- Sensitivity: 0,02 to 20 mV/V
- Bandwidth 10 Hz / 0 Hz to 1 kHz
- Brigde supply: 3 V
- Strain gages: 350 Ω
- Transmission: Radio Sensortelemetry PCM
- Integrated filter
- Resolution: 12 Bit (16 Bit)
- Drift zero: 0,02 (0,01, 0,005 option)
- Supply: 3,3 to 12 V, 50 mA
- Remote range control, auto zero (option)
- Environmental temperature: -25 to +85°C (120°C)
- Max load: 1 000 g (depends on fixing)

Type: MSV_M_<channels>_<accuracy>_<temp>_Fu_<mod>_<sample>_<rmc>_wa_<TC>

2	0,02	85	PCM12	500	-	-
4	0,01	120	PCM16	4000	RMC	TC
8	0,005	150		8000		
				40000		

12 Channel Sensor Signal Amplifier Type M (Standard)

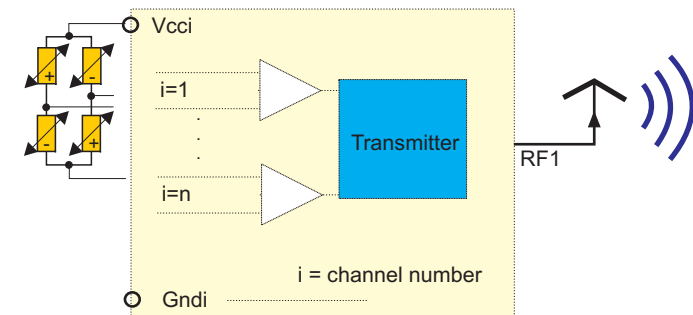
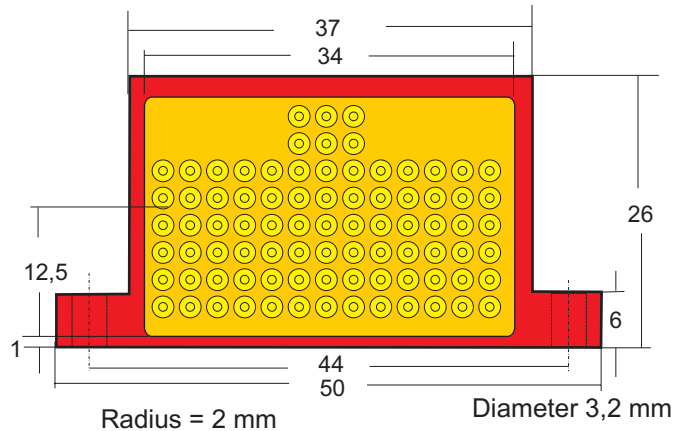

Solder pins

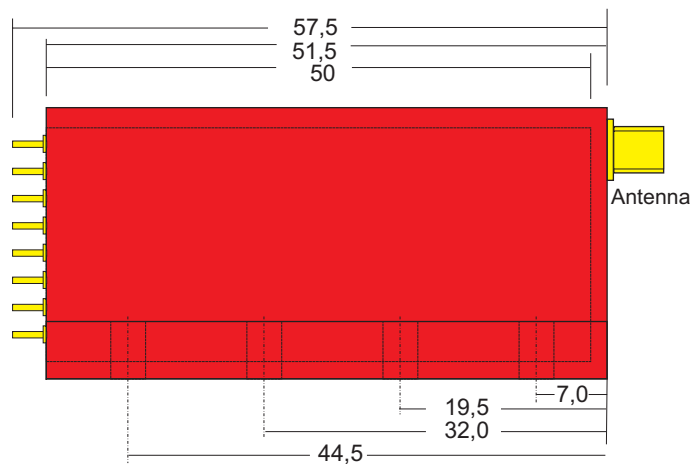

12 Channel Radio Sensortelemetry transmitter

For strain gage, PT100, Thermocouple						
Sensitivity: 0,02 to 20 mV/V						
Bandwidth 10 Hz / 0 Hz to 1 kHz						
Brigde supply: 3 V						
Strain gages: 350 Ω						
Transmission: Radio Sensortelemetry PCM						
Integrated filter						
Resolution: 12 Bit (16 Bit)						
Drift zero: 0,02 (0,01, 0,005 option)						
Supply: 3,3 to 12 V, 50 mA						
Remote range control, auto zero (option)						
Environmental temperature: -25 to +85°C (120°C)						
Max load: 1 000 g (depends on fixing)						
Type: MSV_M_<channels>_<accuracy>_<temp>_Fu_<mod>_<sample>_<rmc>_wa_<TC>						
	12	0,02	85	PCM12	500	-
		0,01	120	PCM16	4000	RMC TC
		0,005	150		8000	
					40000	

16 Channel Sensor Signal Amplifier Type M (Standard)

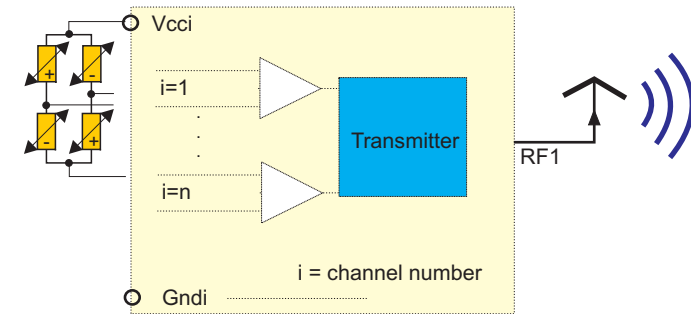
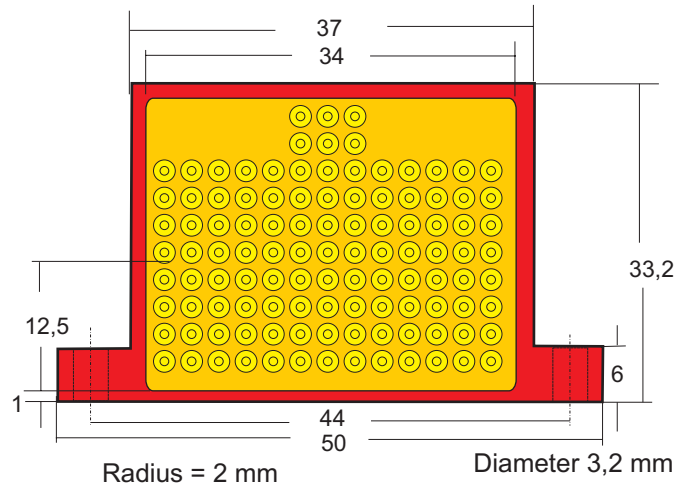

Solder pins

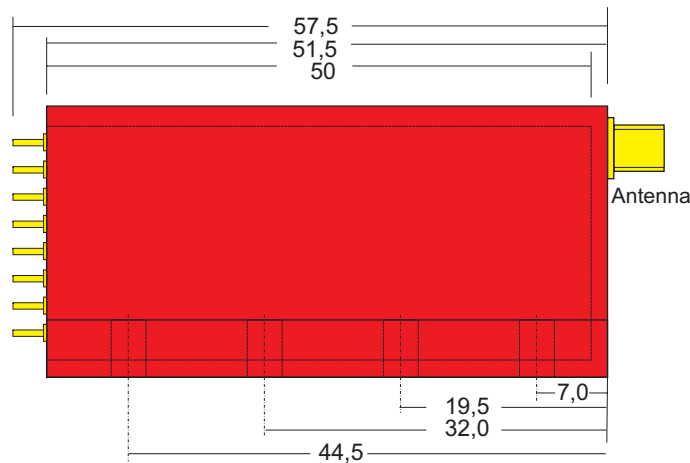

16 Channel Radio Sensortelemetry transmitter

For strain gage, PT100, Thermocouple						
Sensitivity: 0,02 to 20 mV/V						
Bandwidth 10 Hz / 0 Hz to 1 kHz						
Brigde supply: 3 V						
Strain gages: 350 Ω						
Transmission: Radio Sensortelemetry PCM						
Integrated filter						
Resolution: 12 Bit (16 Bit)						
Drift zero: 0,02 (0,01, 0,005 option)						
Supply: 3,3 to 12 V, 50 mA						
Remote range control, auto zero (option)						
Environmental temperature: -25 to +85°C (120°C)						
Max load: 1 000 g (depends on fixing)						
Type: MSV_M_<channels>_<accuracy>_<temp>_Fu_<mod>_<sample>_<rmc>_wa_<TC>						
	16	0,02	85	PCM12	500	-
		0,01	120	PCM16	4000	RMC TC
		0,005	150		8000	
					40000	

Sensor Signal Amplifier Type MSV_R

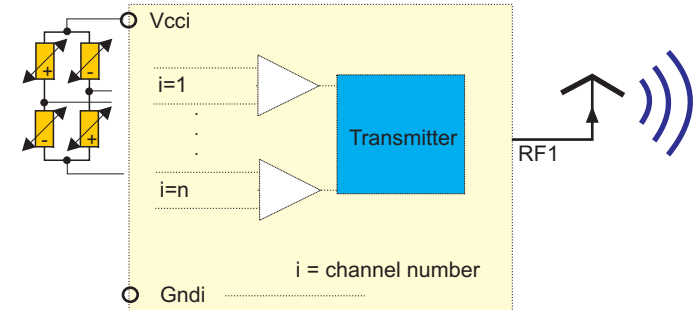
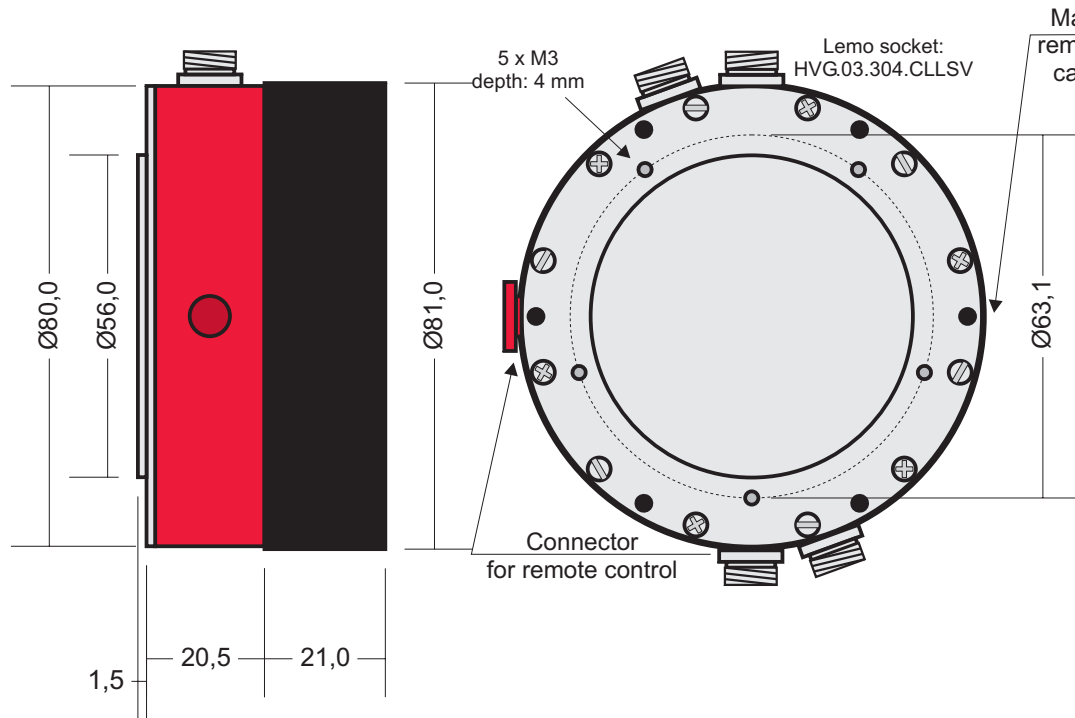

Multi Channel Radio Sensortelemetry transmitter for wheels or end shaft applications

- For strain gage, PT100, Thermocouple
 - Channels: 2, 4, 8, 16
 - Sensitivity: 0,02 to 20 mV/V
 - Bandwidth 10 Hz / 0 Hz to 1 kHz
 - Brigde supply: 3 V, Accu rechargeable
 - Strain gages: 350 Ω
 - Transmission: Radio Sensortelemetry PCM
 - Diameter: 80 mm, height: 43 mm
 - Resolution: 12 Bit (16 Bit)
 - Drift zero: 0,02 (0,01, 0,005 option)
 - Recharging by inductive recharging cap (contactless)
 - Operating time between recharging. 30 hours
 - Activating by switch
 - Remote range control, auto zero (option)
 - Environmental temperature: -25 to +85°C (120°C)
 - Protection IP67
 - Max load: 1 000 g (depends on fixing)
 - Type: MSV_R_<channels>_<accuracy>_<temp>_Fu_<mod>_<sample>_<rmc>_wa_<TC>
- | | | | | | | |
|-----|-------|-----------|-------|------|-----|----|
| 1 | 0,02 | -10+85°C | PCM12 | 500 | - | - |
| ... | 0,01 | -40+120°C | PCM16 | 4000 | RMC | TC |
| 16 | 0,005 | | | | | |

Sensor Signal Amplifier Type MSV_R

special for temperature acquisition at wheels

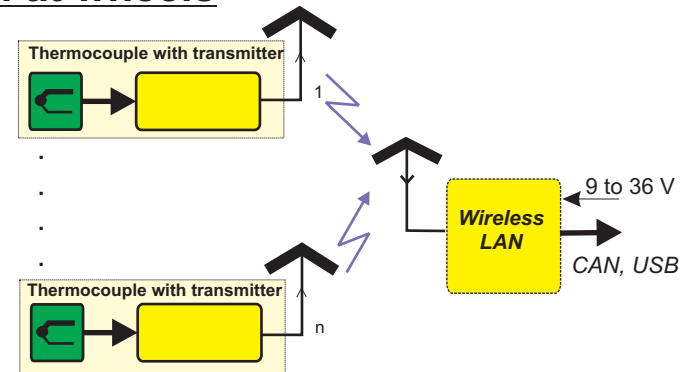
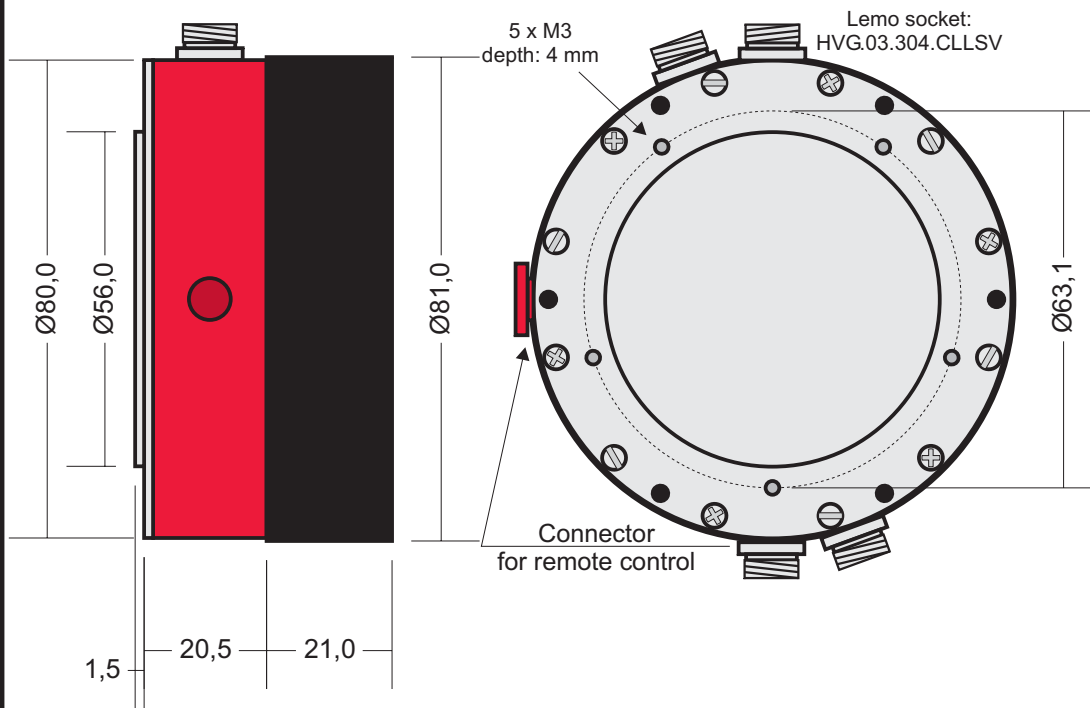

Multi Channel Radio Sensortelemetry transmitter for wheels or end shaft applications

- For Thermocouple type K
- Channels: 2, 4, 8, 16
- Range: -50 to 1000°C
- Sample/sec: 10
- Local aera LAN time multiplex (one frequency)
- Brigde supply: 3 V, Accu rechargeable
- Transmission: Radio Sensortelemetry PCM
- Diameter: 80 mm, height: 43 mm
- Resolution: 12 Bit (16 Bit)
- Drift zero: 0,02 (0,01, 0,005 option)
- Low power consumption, operating time between recharging. 150 hours
- Recharging by inductive recharging cap (contactless)
- Activating by switch
- Environmental temperature: -25 to +85°C (120°C)
- Protection IP68
- Max load: 1 000 g (depends on fixing)

Type: MSV_R_<channels>_<accuracy>_<temp>_Fu_<mod>_<sample>_wa_<TC>

Channels	Accuracy	Temp	Mod	Sample	wa	TC
1	0,02	85	PCM12	1/s	0,1/s	
...	0,01	120	PCM16	10/s		
16	0,005					

32 Channel Sensor Signal Amplifier Type MSV_R

special for helicopter use (IP65)

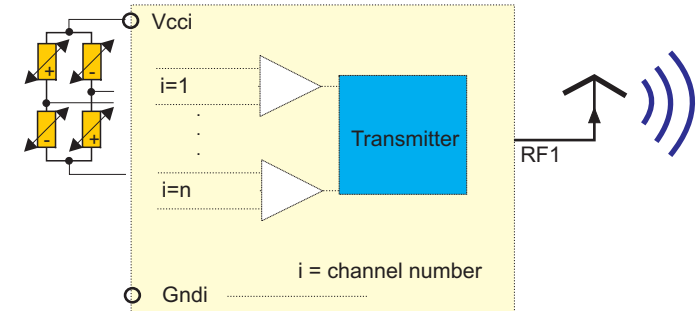
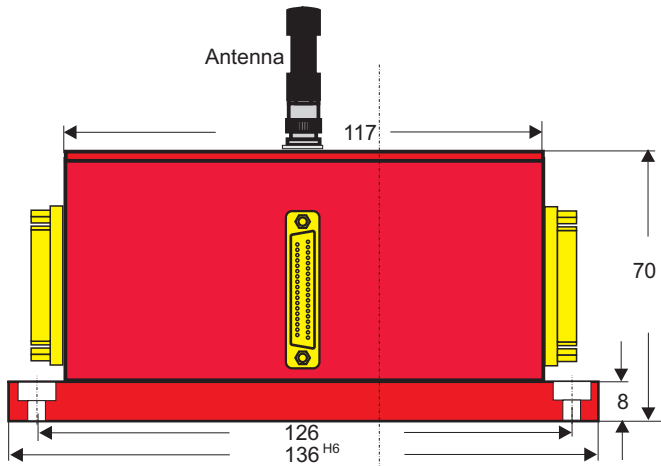

Multi Channel Radio Sensortelemetry transmitter for wheels or end shaft applications

For strain gage (optional thermocouple)				
Transmission: Radio Sensortelemetry PCM (digital transmission)				
Channels: 16, 32				
Sample/channel/sec: 500, 1000, 2000, 4000				
Brigde supply: 3 V,				
Strain gage resistance: 350, (120, 1000) Ω				
Resolution: 12 Bit (16 Bit)				
Range: 0,05 ...16 mV/V (remote via wire and PC adjustable with 12 bits resolution)				
Auto zero/ offset adjust (remote via wire and PC adjustable with 12 bits resolution)				
Drift zero: 0,02 (0,01, 0,005 option)				
Integrated accu pack, 4000 mA/h, rechargeable by connector				
Low power consumption				
Size: Diameter: 136 mm, height: 70 mm				
Environmental temperature: -25 to +85°C (120°C)				
Protection IP54, (IP68 option)				
Max Speed: 3000 RPM (depends on fixing)				
Type: MSV_R_<channels>_<accuracy>_<temp>_Fu_<mod>_samplerate>_<rmc>_wa				
16	0,02	85	PCM12	500
32	0,01	120	PCM16	1000
	0,005			2000
				4000
				8000

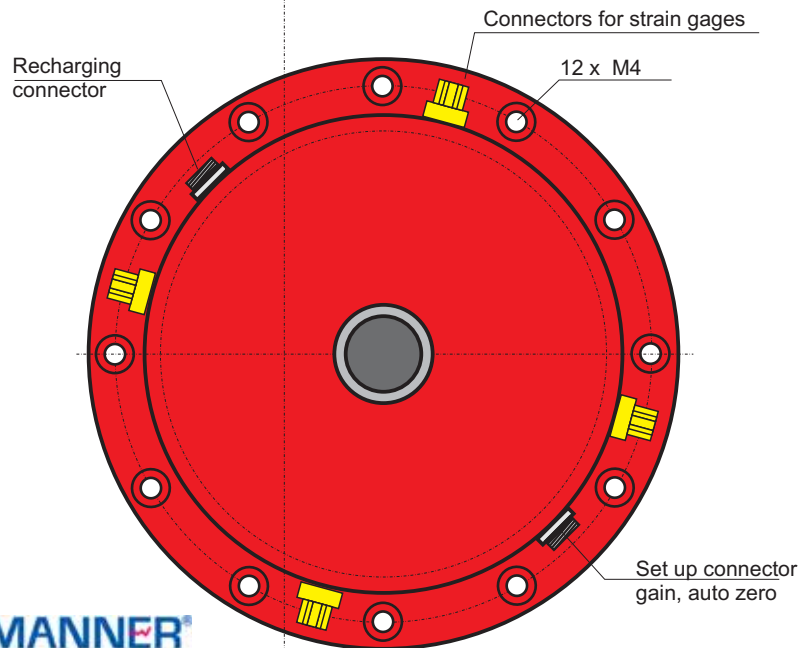

Receiver (AW_D)

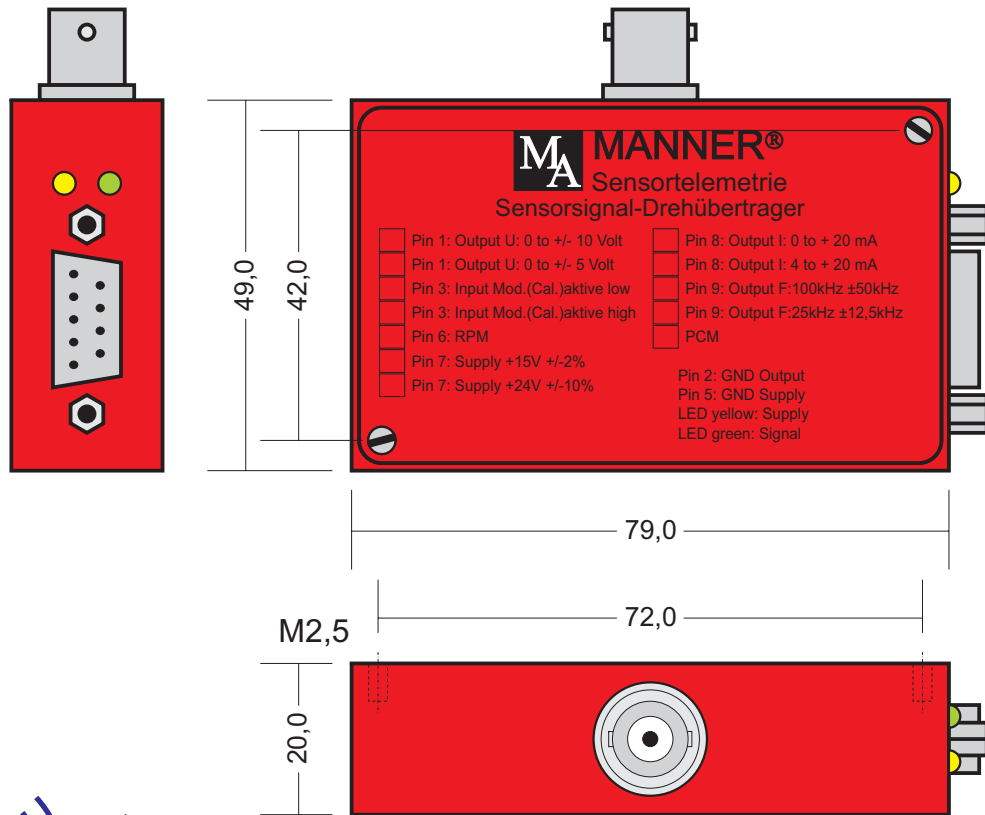

1 Channel Radio Sensortelemetry Receiver

Bandwidth: 0 to 1kHz
 Output: ±10 V (0(4) to 20 mA, frequency, binary, USB)
 RF frequency: 433 MHz
 Transmission: Radio Sensortelemetry PCM
 Integrated filter
 Resolution: 12 Bit (16 Bit)
 Environmental temperature: -25 to +85°C (-45 to +85°C)
 Supply: 24 V (±5%), 15 V (±2%), 9 to 36 V (board supply)
 Type: AW_D_Fu <mod> <bandwidth> <output> <supply>

PCM12	1 kHz	U	15V
PCM16		I	24V

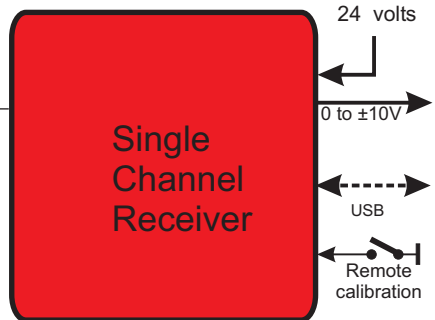
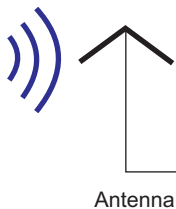

Pin Assignment of the D-Sub connector

- Pin 1 Output -10V to +10V
- Pin 2 GND Output
- Pin 3 do not connect
- Pin 4 do not connect
- Pin 5 GND Power Supply
- Pin 6 do not connect
- Pin 7 Power Supply 24 VDC ±10%
- Pin 8 do not connect
- Pin 9 do not connect

Evaluation Unit (AW_M)

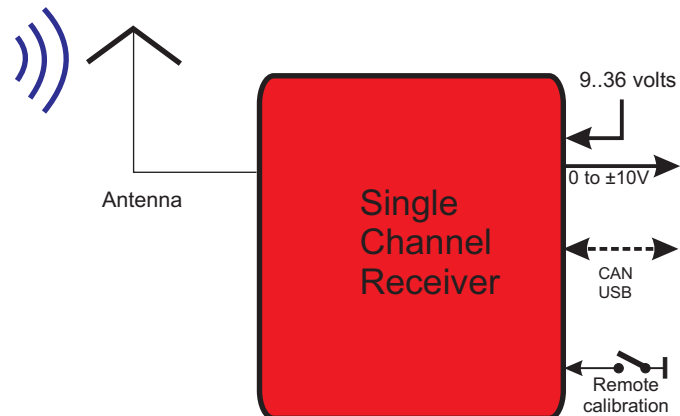
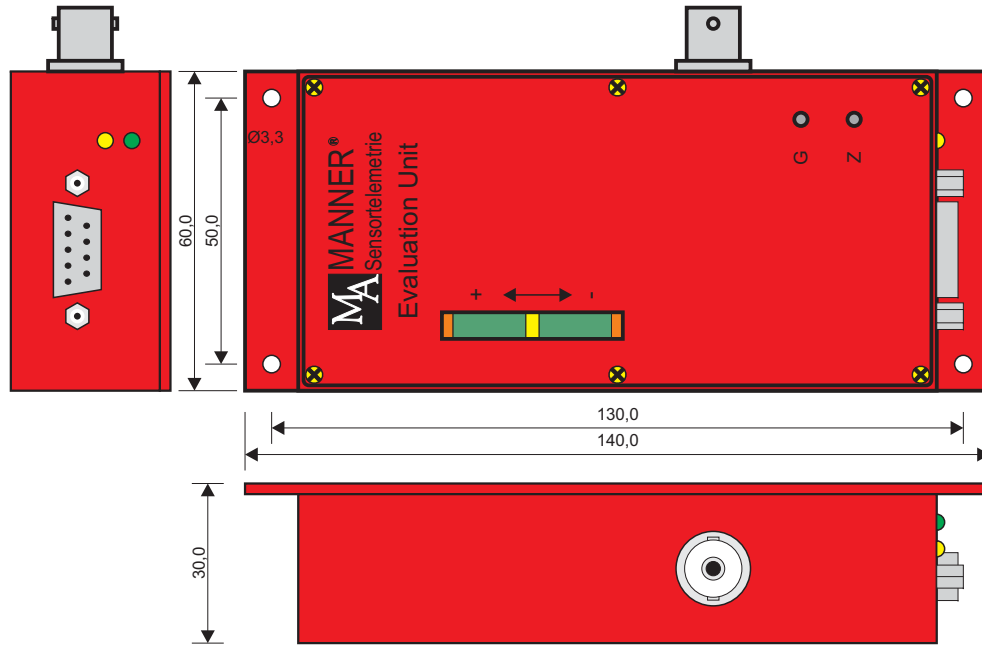

Pin Assignment of the D-Sub connector

- Pin 1 Output -10V to +10V
- Pin 2 GND Output
- Pin 3 Shunt Cal. (active low)
- Pin 4 do not connect
- Pin 5 GND Power Supply
- Pin 6 do not connect
- Pin 7 Power Supply 9 to 36 VDC
- Pin 8 do not connect
- Pin 9 do not connect

1 Channel Radio Sensortelemetry Receiver

- Bandwidth: 0 to 1kHz
- Output: ±10 V (0(4) to 20 mA, frequency, binary, USB)
- RF frequency: 433 MHz
- Transmission: Radio Sensortelemetry PCM
- Integrated filter
- Resolution: 12 Bit (16 Bit)
- Environmental temperature: -25 to +85°C (-45 to +85°C)
- Supply: 24 V (±5%), 9 to 36 V (board supply)
- Type: AW_M_Fu <mod> <bandwidth> <output> <supply>

PCM12	1 kHz	U	15
PCM16		I	24
		B	24B
		USB	

Evaluation Unit (AW_P)

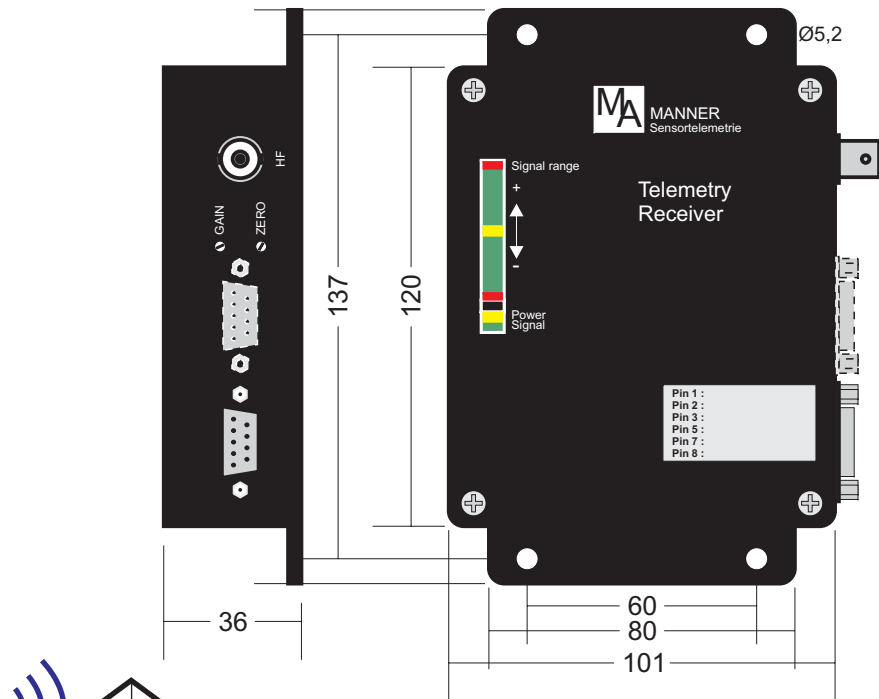

1/2 Channel Radio Sensortelemetry Receiver

Bandwidth:	0 to 1kHz		
Output:	±10 V (0(4) to 20 mA, frequency, binary, USB)		
RF frequency:	433 MHz		
Transmission:	Radio Sensortelemetry PCM		
Integrated filter			
Resolution:	12 Bit (16 Bit)		
Environmental temperature:	-25 to +85°C (-45 to +85°C)		
Supply:	24 V (±5%), 9 to 36 V (board supply)		
Type:	AW_P_Fu <mod> <bandwidth> <output> <supply>		
	PCM12	1 kHz	U 15V
	PCM16		I 24V
			B 24V
			USB

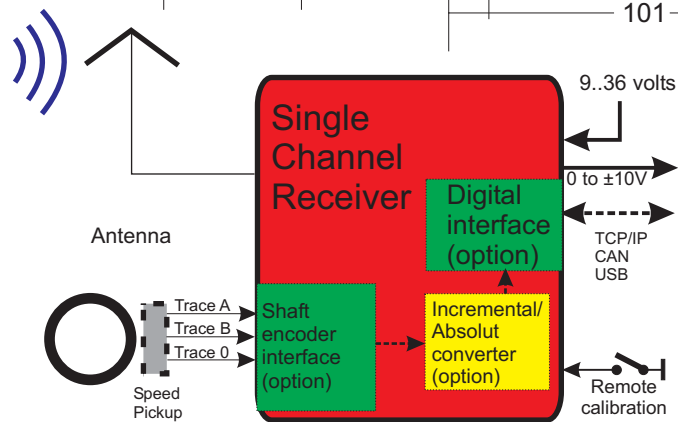

Pin Assignment of the D-Sub connector

- Pin 1 Output -10V to +10V
- Pin 2 GND Output
- Pin 3 Shunt Cal. (active low)
- Pin 4 do not connect
- Pin 5 GND Power Supply
- Pin 6 do not connect
- Pin 7 Power Supply 9 to 36 VDC
- Pin 8 do not connect
- Pin 9 do not connect

Evaluation Unit (AW_F) Digital Receiver

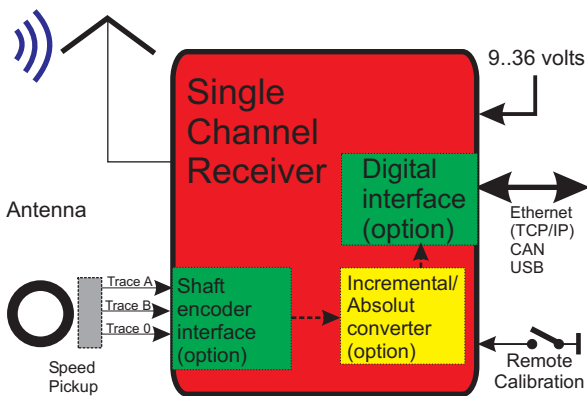
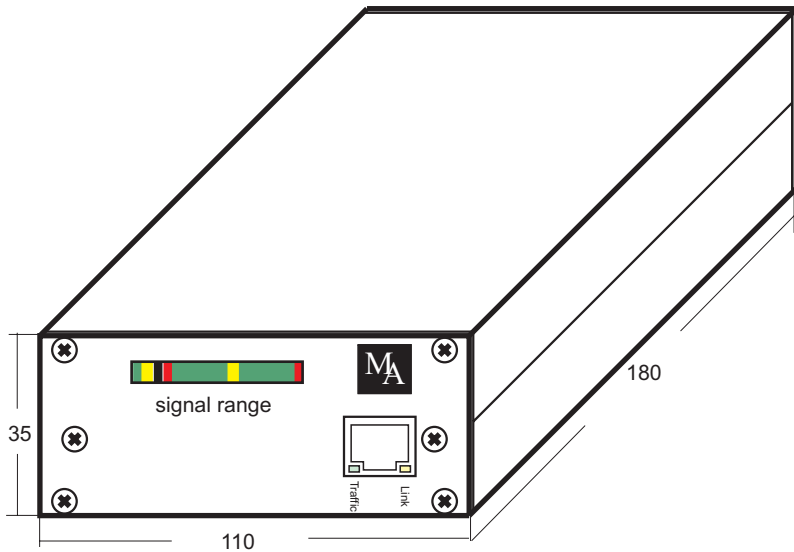

Pin Assignment of the D-Sub connector

- Pin 1 Data
- Pin 2 GND Output
- Pin 3 not connected
- Pin 4 Data
- Pin 5 GND Power Supply
- Pin 6 Trace 0 (option)
- Pin 7 Power Supply 9 to 36 VDC
- Pin 8 Data
- Pin 9 Data
- Pin 10 Trace A (option)
- Pin 11 Trace B (option)
- Pin 12 not connected
- Pin 13 not connected
- Pin 14 not connected
- Pin 15 not connected

Multi Channel PCM Receiver

- Bandwidth: 0 to 1kHz (10 kHz)
- Number of channels: 1..32
- Output: ± 10 V, (0(4) to 20 mA option)
- Digital interface (option): SPI, USB, CAN, Ethernet (TCP/IP)
- Frequency 433 Mhz, (750 MHz)
- Transmission: inductive sensortelemetry PCM
- Resolution: 12 Bits, (16 Bit*)
- Remote shunt calibration
- Environmental temperature range: -25 to +85°C (-45 to +85°C)
- Supply: 24 V DC (+/-5%), 15 V DC (+/-2%), 9 to 36 V DC (board supply)
- Type: MAW_F_<channels>_Fu_<mod>_<samplerate>_<supply>_<output>

2	PCM12	40000	15	USB
4	PCM16	20000	24	CAN
8		8000	24B	TCP/IP
12		4000		HS
16		2000		
		1000		
		1 *		

*Option: current save mode for extrem long Battery lifetime

Evaluation Unit (AW_ES)

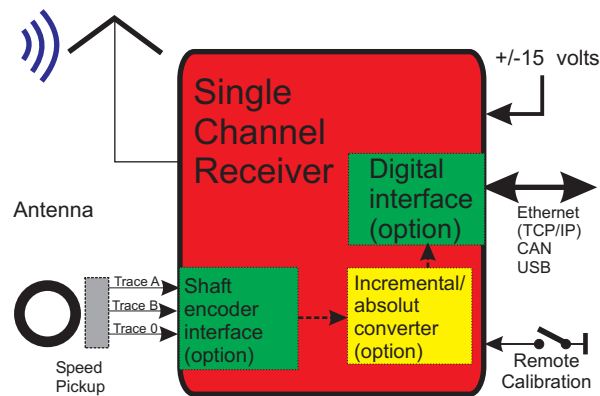

1 Channel Radio Sensortelemetry Receiver

Bandwidth: 0 to 1kHz

Output: ± 10 V (0(4) to 20 mA, frequency, binary, USB)

RF frequency: 433 MHz

Transmission: Radio Sensortelemetry PCM

Integrated filter

Resolution: 12 Bit (16 Bit)

Environmental temperature: -25 to +85°C (-45 to +85°C)

Supply: +/-15V

Type: AW_ES_Fu_<mod>_<samplerate>_<supply>_<output>

PCM12 1 kHz +/-15 U

PCM16 2 kHz I

10 kHz

Evaluation Unit (84TE)

Front side

depth 300 mm

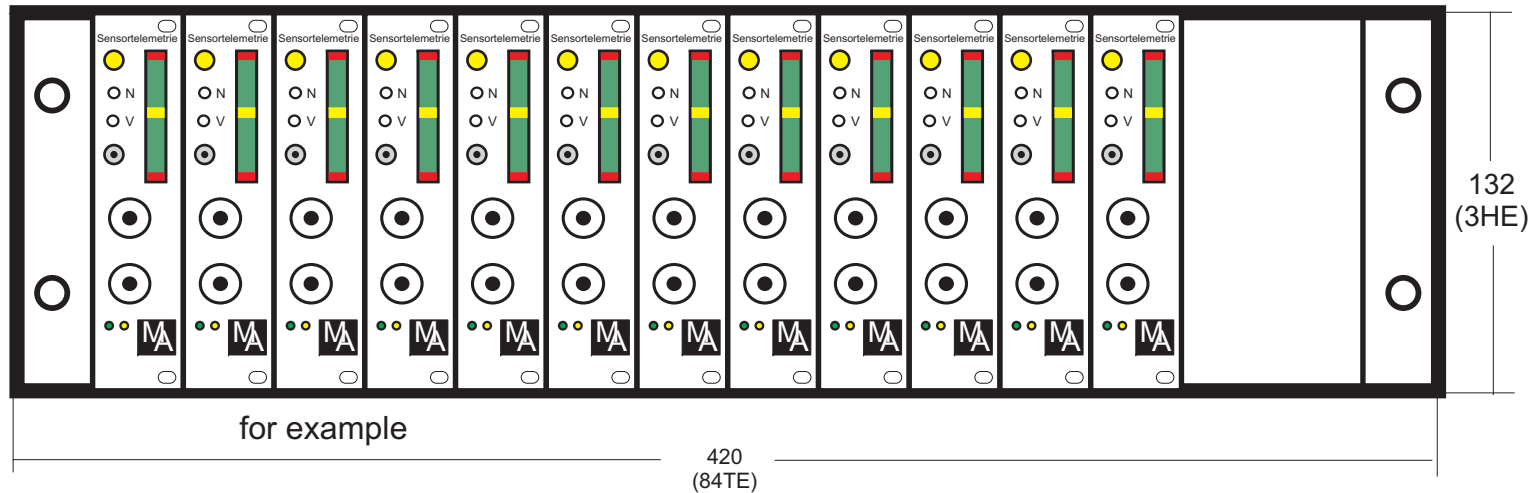

1/2/4/8 Channel PCM Receiver with Single Channels

Bandwidth: 0 to 1kHz

Output: ± 10 V, (0(4) to 20 mA, binary, USB)

Transmission: Radio Sensortelemetrie PCM

Integrated filter

Resolution: 12 Bit (16 Bit)

Max. Plugin cards: 12 (single channels)

Environmental temperature: -25 to +65°C

Supply: 9 to 270 V AC, 9 to 36 V (board supply) DC

Type: AW_84TE_Fu_<mod>_<samplerate>_<supply>_<output>

1 kHz	1	230V	U	PCM12
2 kHz	2	24V	I	PCM16
10 kHz	4		B	
	8		USB	

Evaluation Unit (84TE)

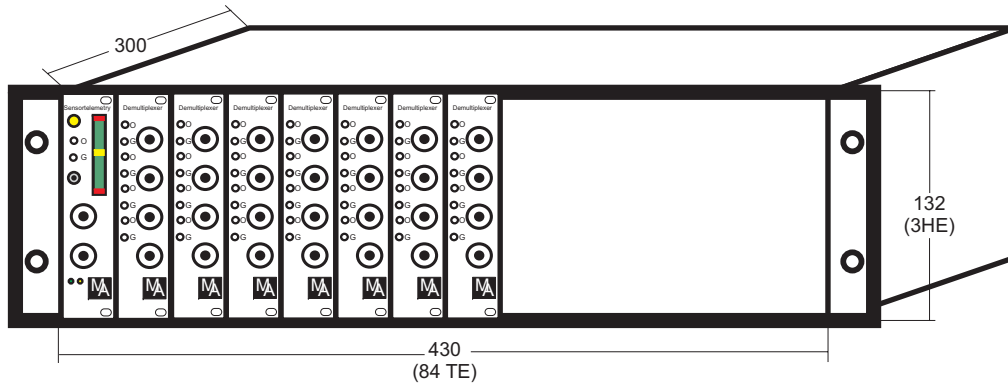

Front side

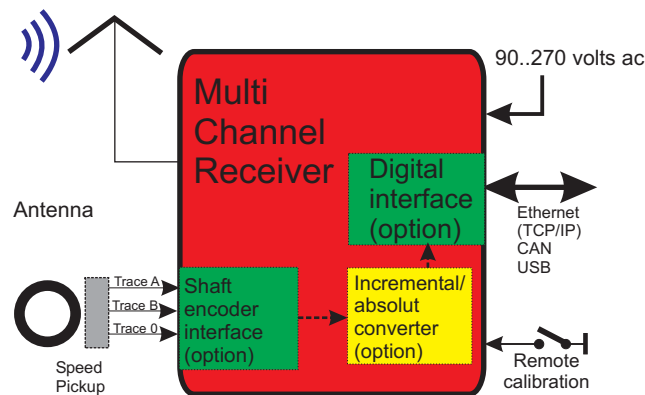

1/2/4/8/16/32 Channel FM/PCM Receiver

Bandwidth: 0 to 1kHz

Output: ± 10 V, (0(4) to 20 mA, binary, USB)

Transmission: Radio Sensortelemetrie PCM

Integrated filter

Resolution: 14 Bit (16 Bit)

Remote shunt calibration

Environmental temperature: -25 to +65°C

Supply: 90 to 270 V AC, 9 to 36 V (board supply) DC

Type: MAW_84TE_<channels>_Fu_<mod>_<samplerate>_<supply>_<output>

1	PCM12	8000	230V	U
2	PCM16	4000	24B	I
4		2000		B
8		1000		USB
16		1 *		CAN
32				TCP

Evaluation Unit (42TE)

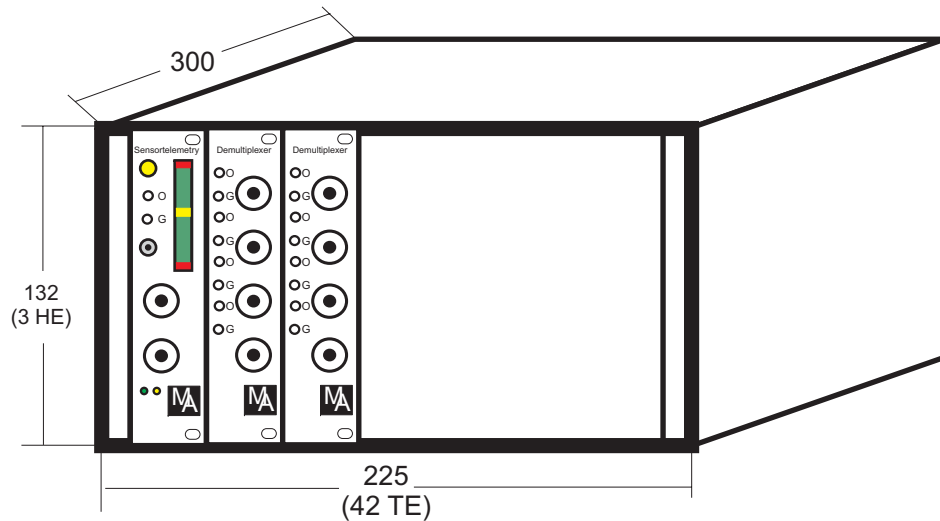

Front side

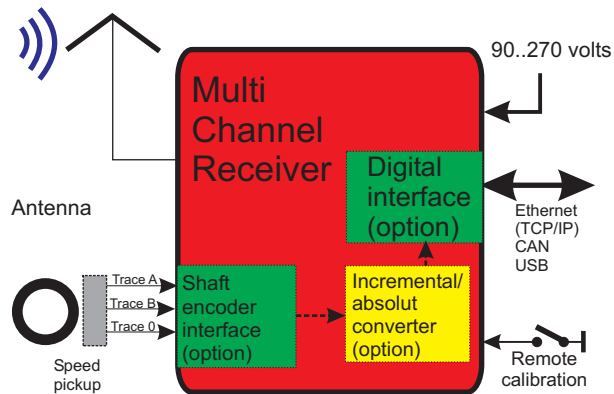

1/2/4/8 Channel FM/PCM Receiver

Bandwidth: 0 to 1kHz

Output: ± 10 V, (0(4) to 20 mA, binary, USB)

Transmission: Radio Sensortelemetrie PCM

Integrated filter

Resolution: 14 Bit (16 Bit)

Remote shunt calibration

Environmental temperature: -25 to +65°C

Supply: 90 to 270 V AC, 9 to 36 V (board supply) DC

Type: MAW_42TE_<channels>_Fu_<mod>_<samplerate>_<supply>_<output>

1	PCM12	8000	230V	U
2	PCM16	4000	24B	I
4		2000		B
8		1000		USB
		1 *		CAN
				TCP

Evaluation Unit (22TE)

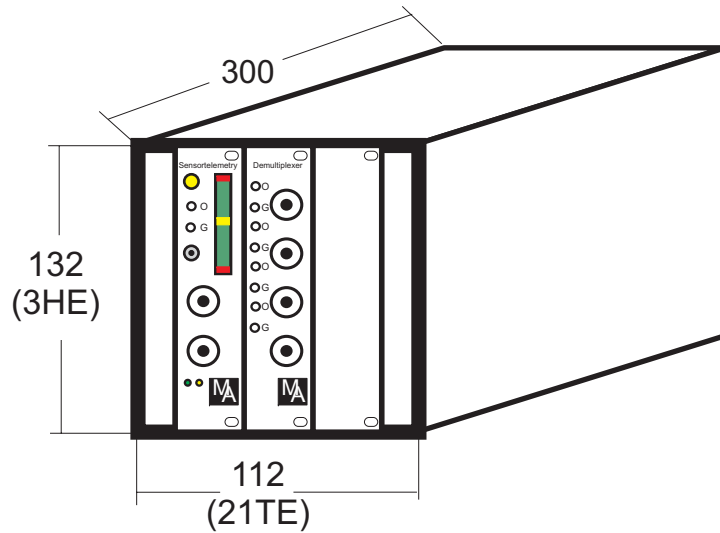

Front side

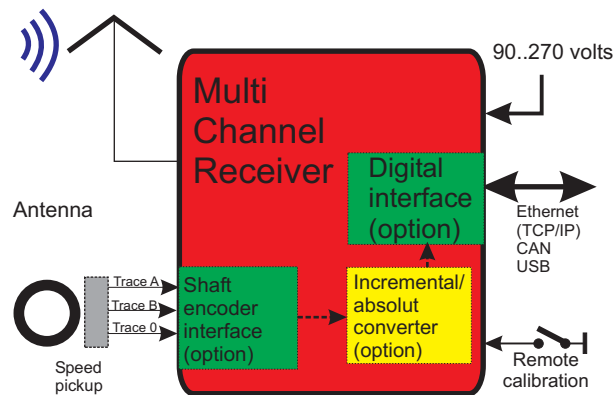

1/2/4 Channel FM/PCM Receiver

Bandwidth: 0 to 1kHz				
Output: ±10 V, (0(4) to 20 mA, binary, USB)				
Transmission: Radio Sensortelemetrie PCM				
Integrated filter				
Resolution: 14 Bit (16 Bit)				
Remote shunt calibration				
Environmental temperature: -25 to +65°C				
Supply: 90 to 270 V AC, 9 to 36 V (board supply) DC				
Type: MAW_22TE_<channels>_Fu_<mod>_<samplerate>_<supply>_<output>				

1	PCM12	8000	230V	U
2	PCM16	4000	24B	I
4		2000		B
		1000		USB
		1 *		CAN
				TCP

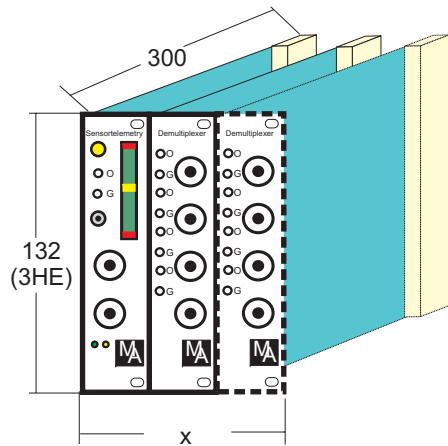

Front side

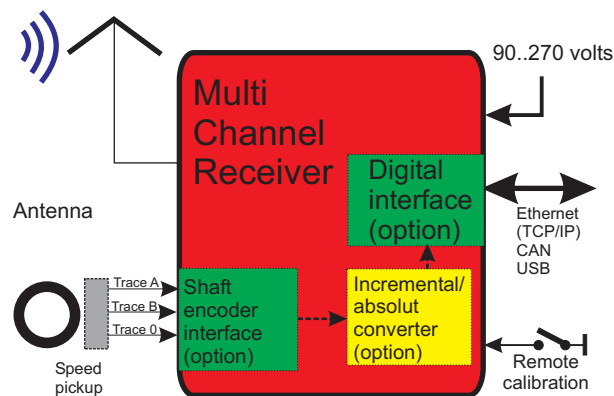

1/2/4/8 Channel FM/PCM Receiver

Bandwidth: 0 to 1kHz

Output: ± 10 V, (0(4) to 20 mA, binary, USB)

Transmission: Radio Sensortelemetrie PCM

Integrated filter

Resolution: 14 Bit (16 Bit)

Remote shunt calibration

Environmental temperature: -25 to +65°C

Supply: +/-15 volts DC

Type: MAW_Es_ <channels> _Fu_ <mod>_ <samplerate>_ +/-15V_ <output>

1	PCM12	8000	U
2	PCM16	4000	I
4		2000	B
8		1000	USB
		1 *	

Alternative Battery or inductive Supply



Pin Assignment of the D-Sub connector

- Pin 1 Output -10V to +10V
- Pin 2 GND Output
- Pin 3 Shunt Cal. (active low)
- Pin 4 do not connect
- Pin 5 GND Power Supply
- Pin 6 do not connect
- Pin 7 Power Supply 9 to 36 VDC
- Pin 8 do not connect
- Pin 9 do not connect

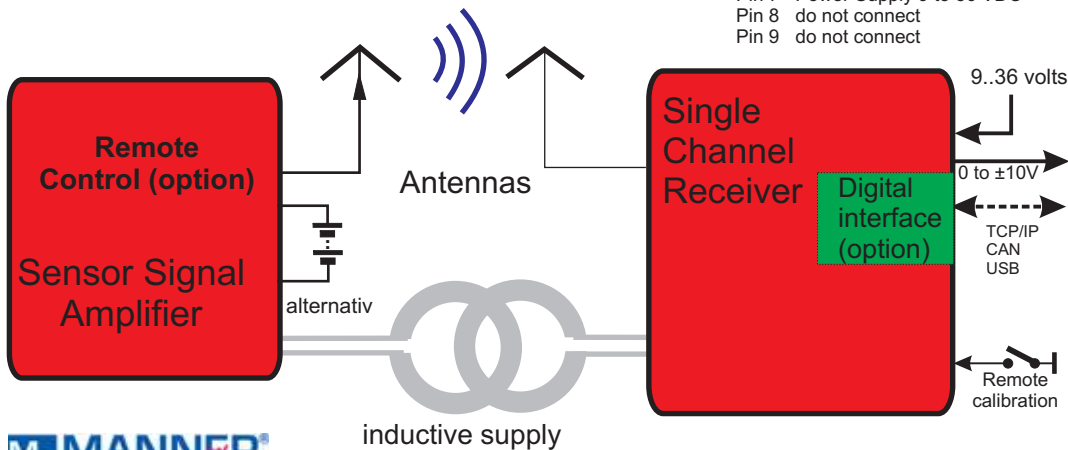

1/2 Channel Radio Sensortelemetry Receiver

Bandwidth: 0 to 1kHz

Output: ±10 V (0(4) to 20 mA, frequency, binary, USB)

RF frequency: 433 MHz

Transmission: Radio Sensortelemetry PCM

Supply battery 3,6..12 volts or inductive 3,2 MHz

Integrated filter

Resolution: 12 Bit (16 Bit)

Environmental temperature: -25 to +85°C (-45 to +85°C)

Supply: 24 V (±5%), 15 V (±2%), 9 to 36 V (board supply)

Type: AW_F_Fu_<mod>_<bandwidth>_<power>_<supply>_<output>

PCM12	1kHz	15	U
PCM16		24B	I

B

USB

Receiving / Transmitting Antenna with magnetic Foot

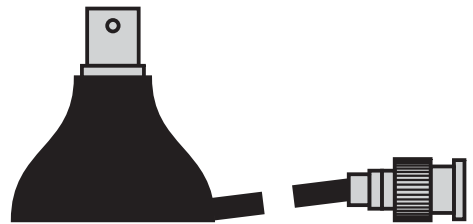
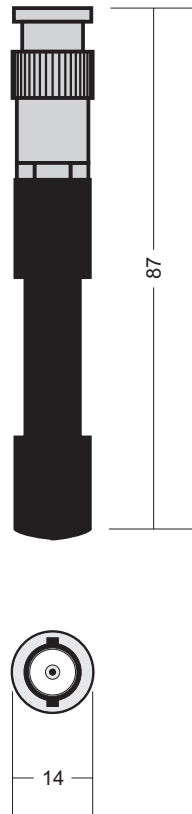

Coaxial cable RG58
Max. length 10 m

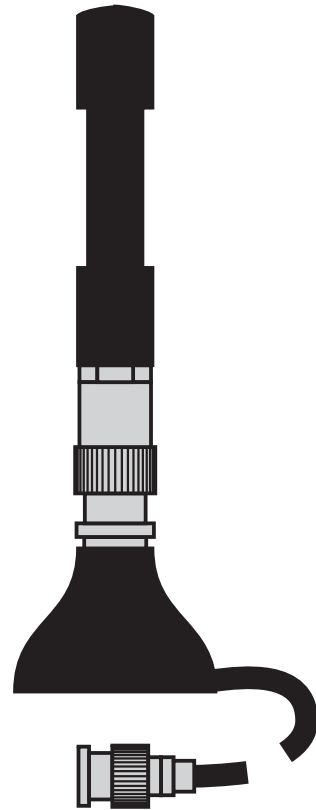
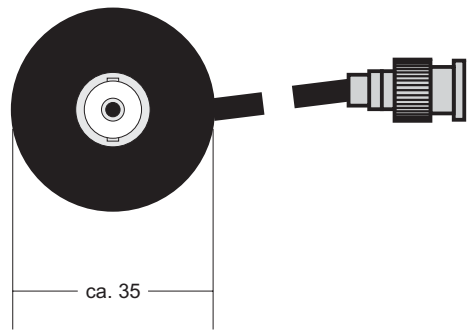

Features

Receiving Antenna			
Frequency 433 MHz			
Height: 87 mm			
Magnic foot			
Coax cable power max. 50 W			
Cable length: 5 m			
Environmental temperature: -35 to +85°C			
Type: AFu_<Temp>_PCM_<wa>_<St>			
-10	+85	-	BNC
-25	+125	wa	TNC
-40	+160		SMA
			Lemo
			N

Transmitting Antenna			
type rod			
Frequency 433 MHz			
Height: 87 mm			
Environmental temperature: -10 to +85°C			
Type: Rot_FuS_<St>_<wa>_<Temp>_PCM			
		TNC	-10 +85
		SMA	wa -25 +125
		N	-40 +160

Transmitting Antenna			
type wire			
Frequency 433 MHz			
Height: 87 mm			
Environmental temperature: -10 to +85°C			
Type: Rot_FuD_SMA_<wa>_<Temp>_PCM			
		-	-10 +85
		wa	-25 +125
			-40 +160

Setup of the Interface Software

(Software Package Remote Control)

MENUE -> SETUP -> HARDWARE CONFIGURATION

Choice between the various interface configurations. Please see separate configuration sheet or the marked settings beside.

The setup of the interface has to be configured for each single user of your computer.

Settings for RPM Channel (optional):

Settings have to be made for correct RPM display in the software.

Averaging factor has an effect on a fluctuating rpm value especial at high rotational frequencies.

Type in the proper samplerate from the technical data on the last pages of the documentation.

MENUE -> SETUP -> SOFTWARE CONFIGURATION

Display Settings

Coice between standard-systems and temperature-systems

Data File Format for Aquisition:

Coice between binary format and ASCII format

Integrated Remote Control

Activates or deactivates functions for RMC-programming of systems, which support data-aquisition and programming over the same USB-interface

Calibration Command (for non-RMC-systems)

If this function is supported by the hardware the remote calibration function can also activated by the software

Different interfaces

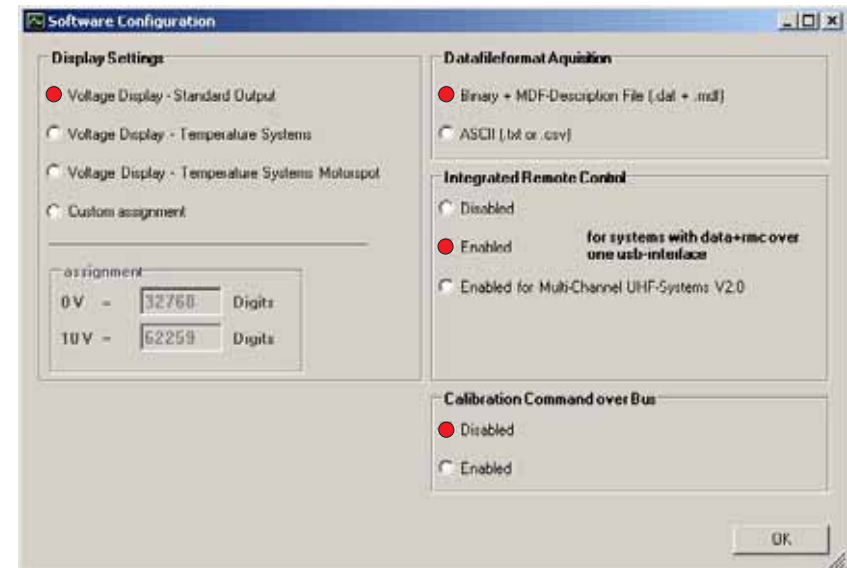
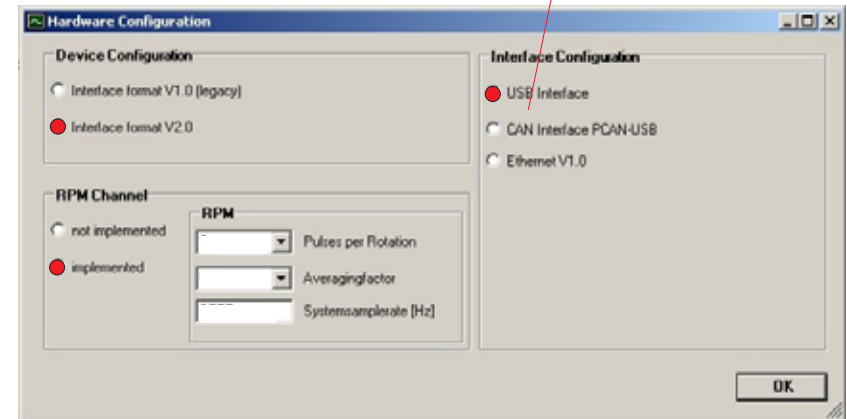

Using of Remote Control Function

(Software Package Remote Control)

Adjustment:

With this function an additional window for RMC settings is opened.
(see following page)

Cal on:

Via the RMC command the shunt calibration is activated.

Cal off:

Via the RMC command the shunt calibration is deactivated.

Test Connection

Start / Stop of the test transmission. With this function a RMC command is send cyclic.
In the area 'Status Info' the replies can be checked.

Status-Info:

Transmit: By transmission of a command in the first array of the 'Status Info' area the informtaion 'Transmit' is displayed (in green letters).
In case of an inactive status the array is grey.

Acknowledge or Error status: After sending a command, the replay is displayed here.
After a successful transmission 'Acknowledge' is displayed (in green letters).
During an error status, the array in which 'Transmit' appears is marked red.
In this array the 'Error status' is shown.



Using of Remote Control Function

(Software Package Remote Control)

Digital value of the sensitivity
 0 to 4095 - Min value = high gain
 Max value = low gain
 Doubling the sensitivity is
 about half of the gain.

Digital value of the zero point
 (0 to 4095) 2048 is about in
 the middle

Number	Description	Gain	Command	Zeropoint	Command	Autozero
Channel 1	Sensor A	2800	Send Gain	2048	Send Zero	Autozero
Channel 2	Sensor B	2800	Send Gain	2048	Send Zero	Autozero
Channel 3	Sensor C	2800	Send Gain	2048	Send Zero	Autozero
Channel 4	Sensor D	2800	Send Gain	2048	Send Zero	Autozero

Setting of the RMC channel number of the telemetry system

Transmission of 'Gain' or 'Zeropoint' of the relevant channel

automatic zero adjustment

Loading / storing of settings

Presetting of the memory

Transmission of the complete set of settings to the rotor electronic (Gain and Zero point for all selected channels)

Interface - Software

(Software Package data acquisition - optional)

Display selection
Configuration/Bargraph-Oscilloscope/Data recording

Information about
data rate, sample rate etc.

Display of the binary values
as they are sent
(inverse to the output at the
evaluation unit)

Display of the selected device
(if multiple available)

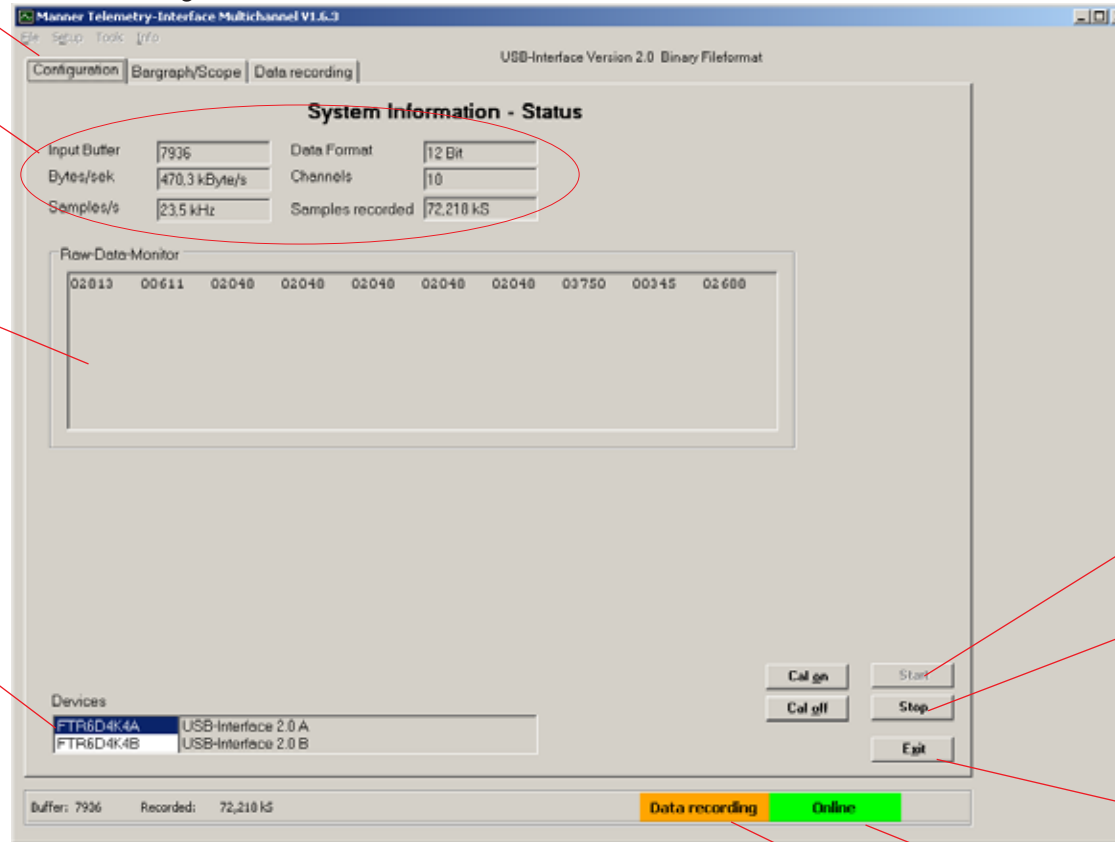

Start data display

Stop data display

Exit program
When data recording is active
then stop data recording before
exiting the program to
prevent loss of data

Activity display (green)
at data transmission
from the Telemetry System

Activity display (green)
at file operation

No other program must be active at the PC while recording data into a file.
This can effect a loss of data.

Control of Data acquisition

(Software Package data acquisition - optional)

Start recording into a file

Stop recording into a file

Show data with additional data viewer PVIEW - if installed

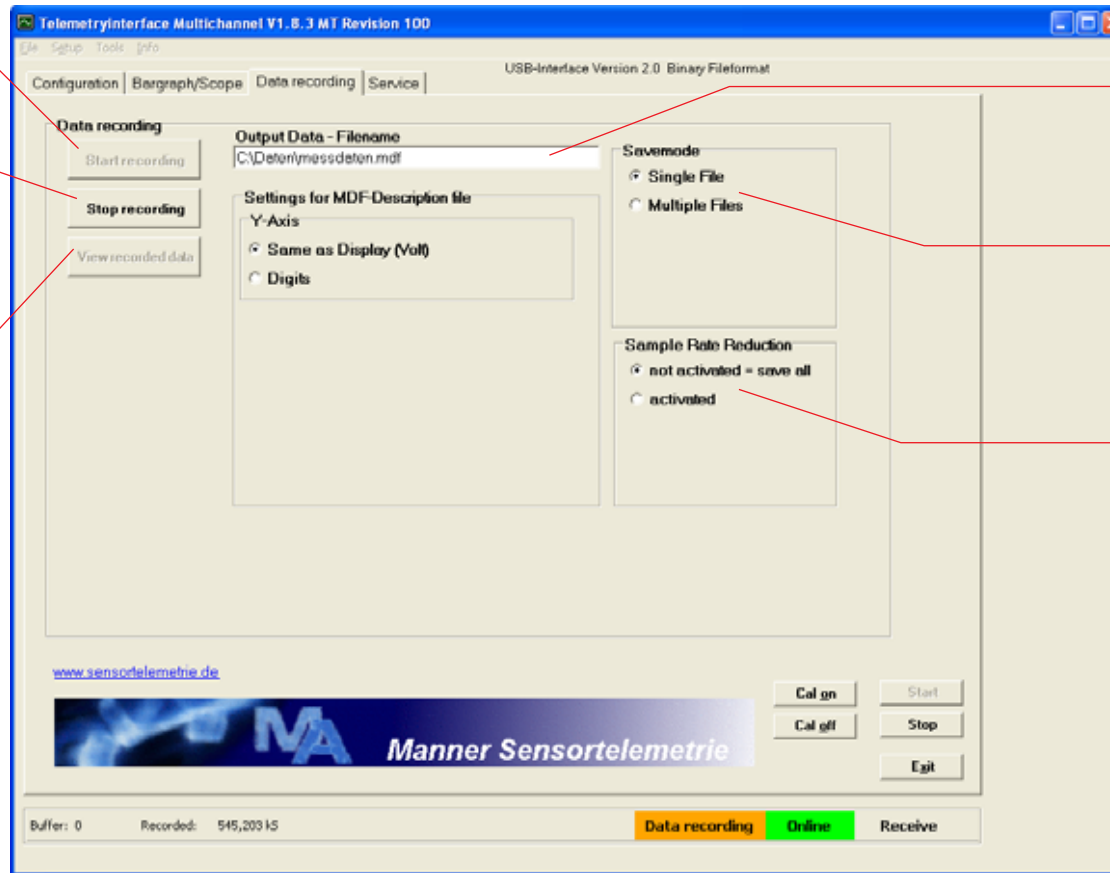

file name

recording of the measurement data in a single file or in multiple files (to define in periods)

reducing of the sampling rate

No other program must be active at the PC while recording data into a file.

This can effect in buffer overflow and the loss of data. If buffer overflow occures, it will be displayed in a field on the left side of "Data recording"

Due to some limitations, the maximum filesize should not exceed 4GB.

Data Display Software Pview

(Software Package Data Acquisition - optional)

Visualisation of recorded Data

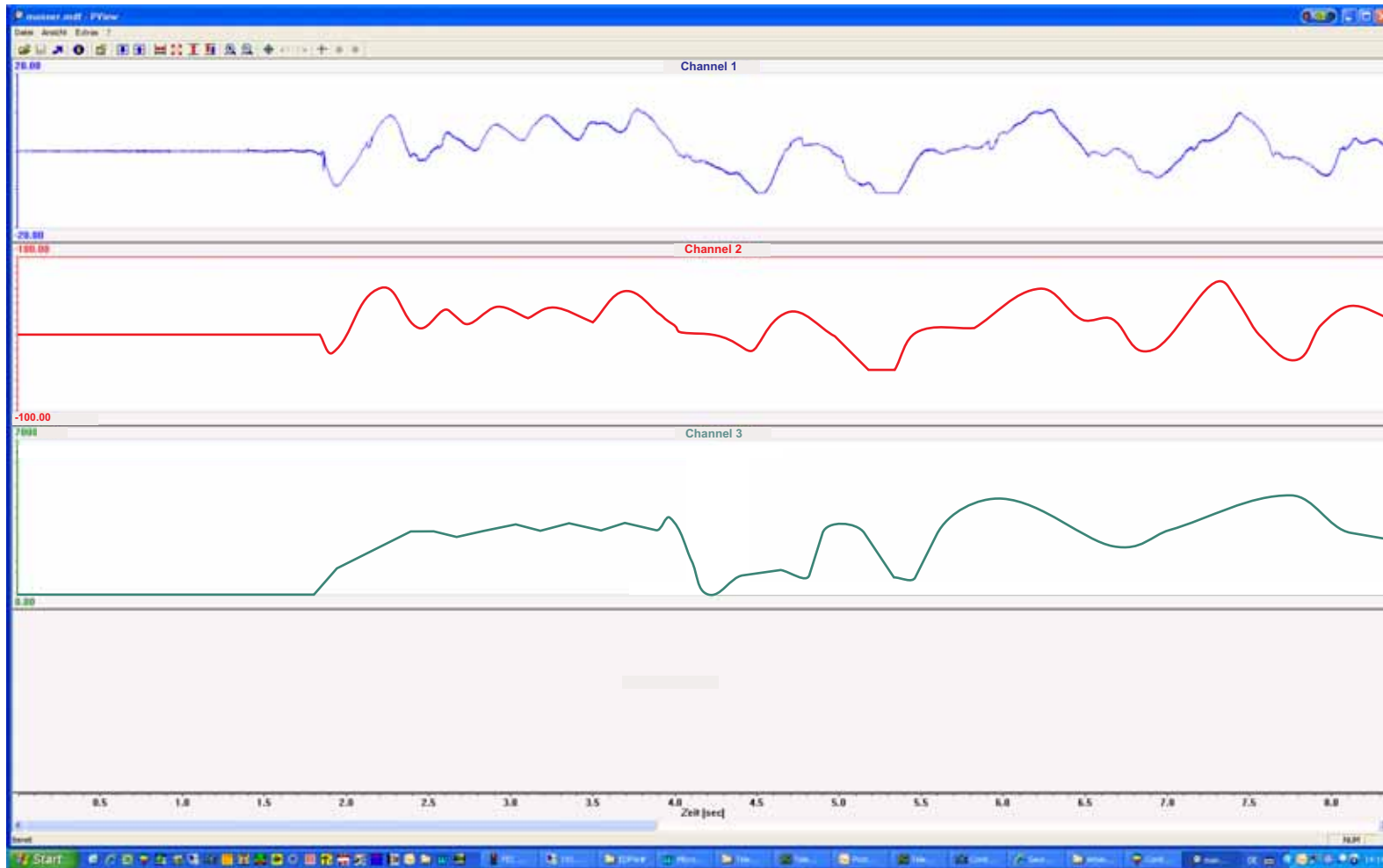

Data File - Binary Format

(Software Package Data Acquisition - optional)

Data Format

The data are recorded in the MDF format.

Two files are generated. One binary file with the ending '.DAT' and one belonging description file with the ending '.MDF'.

The description file is necessary for the data viewing software PVIEW from Stiegele Datensysteme GmbH.

The binary file can be used from other data display or data analysing systems that are able to import digital values.

Correlation of the measured values:

The range of a 12 bit system is from 0 to 4095, the range of a 16 bit system is from 0 to 65535

Assignment to the analog values (custom specific systems and temperature-systems can differ from these values):

Range	Analog value	Digital value (16 Bit-system)	Digital value (12 Bit-system)
-100%	-10V	3277	205
0%	0V	32768	2048
+100%	+10V	62259	3891

Values out of this range are not inside the measuring range and cannot be displayed correctly at the analog outputs.

The analog value can be calculated by the following equation: $U_{out} [V] = (\text{Digitvalue} - 32768) / 2949.1$ (16Bit) or $U_{out} [V] = (\text{Digitvalue} - 2048) / 184.3$ (12Bit)

(This correlation is only valid with calibrated analogue-output)

Format of the Binary File (.DAT)

Definition: LB= Low Byte, HB=High-Byte, CHx = Channel x
(e.g. Ch1 = Channel 1 corresponding to the analog output channel at the evaluation unit)

First the Low-Byte and then the High-Byte of a channel is recorded.

LB-K17, HB-K17, LB-K16, HB-K16, ... , LB-K1, HB-K1 (first data set)

LB-K17, HB-K17, LB-K16, HB-K16, ... , LB-K1, HB-K1 (next data set)

...

LB-K17, HB-K17, LB-K16, HB-K16, ... , LB-K1, HB-K1 (last data set)

Channel 17
E2=Low Byte channel 17
0F=High Byte channel 17

Channel 0

Channel 17
next data set

Sample file shown with a Hex Viewer

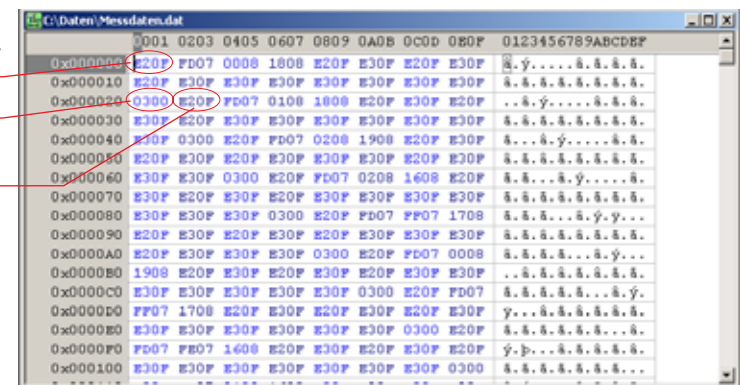

Data File - ASCII Format

(Software Package Data Acquisition - optional)

Data Format

The data are recorded in the CSV-Format.

The measured values are separated with a semicolon. After each complete data set a 'Carriage Return' + 'Linefeed' is added.

The channel description is in the first row of the file.

Correlation of the measured values:

The range of a 12 bit system is from 0 to 4095, the range of a 16 bit system is from 0 to 65535

Assignment to the analog values (custom specific systems and temperature-systems can differ from these values):

Range	Analog value	Digital value (16 Bit-system)	Digital value (12 Bit-system)
-100%	-10V	3277	205
0%	0V	32768	2048
+100%	+10V	62259	3891

Values out of this range are not inside the measuring range and cannot be displayed correctly at the analog outputs.

The analog value can be calculated by the following equation: $U_{out} [V] = (\text{Digitvalue} - 32768) / 2949.1$ (16Bit) or $U_{out} [V] = (\text{Digitvalue} - 2048) / 184.3$ (12Bit)
(This correlation is only valid with calibrated analogue-output)

Format of the ASCII File

The sample shows a recorded dataset of a 16 channel system:

```
CH16; CH15; CH14; CH13; CH12; CH11; CH10; CH09; CH08; CH07; CH06; CH05; CH04; CH03; CH02; CH01
02050; 02047; 02047; 02047; 02050; 02049; 02048; 02050; 02046; 02050; 02047; 02604; 02050; 02050; 02047; 02047
02050; 02047; 02047; 02046; 02050; 02049; 02048; 02050; 02046; 02050; 02047; 02626; 02050; 02050; 02047; 02047
02050; 02047; 02047; 02047; 02050; 02049; 02048; 02050; 02046; 02050; 02047; 02624; 02050; 02050; 02047; 02047
02050; 02047; 02047; 02047; 02050; 02049; 02048; 02050; 02046; 02050; 02047; 02605; 02050; 02047; 02047; 02047
02050; 02047; 02047; 02047; 02050; 02049; 02048; 02050; 02046; 02050; 02047; 02572; 02050; 02047; 02047; 02047
02050; 02047; 02047; 02047; 02050; 02049; 02048; 02050; 02046; 02050; 02047; 02561; 02050; 02050; 02047; 02047
```

Signal Test Function via Scope Function

(Software Package Data Acquisition Modul - optional)

Values, which are displayed in Volt accords to the voltage output to standard-systems. Temperature-measurement-systems or custom calibrated systems can differ from these values.

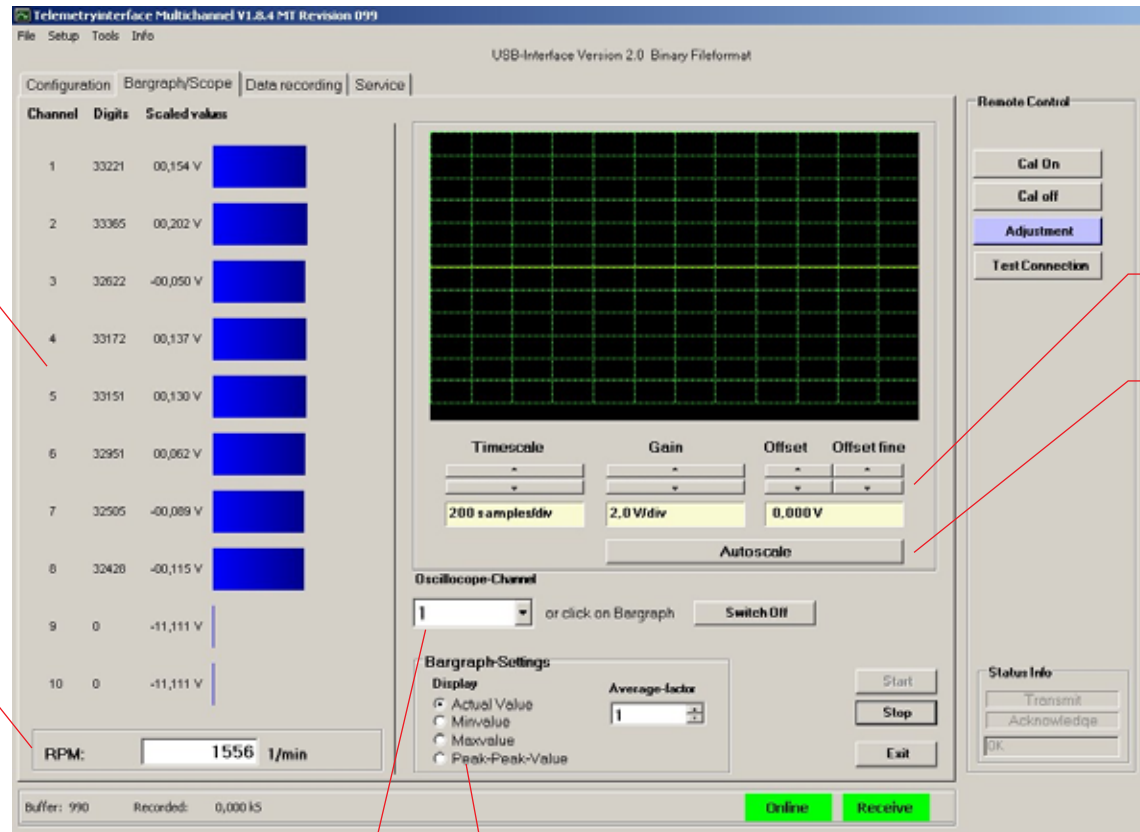

Display of the received data of the measuring channels showing the digital values, the equivalent analog values

Selection of time, gain and offset

Autoscale function for the settings of gain and offset

Display of RPM

Selection of the channel shown at the oscilloscope

Analyse functions for the display

Channel Assignment

Series in the binary file	Assigned analog output channel	Description
1	16	PT100
2	15	ICP
3	14	not used
4	13	not used
5	12	Strain gage channel 12
6	11	Strain gage channel 11
7	10	Strain gage channel 10
8	9	Strain gage channel 9
9	8	Strain gage channel 8
10	7	Strain gage channel 7
11	6	Strain gage channel 6
12	5	Strain gage channel 5
13	4	Strain gage channel 4
14	3	Strain gage channel 3
15	2	Strain gage channel 2
16	1	Strain gage channel 1
17	--	Rotation angle

Anpassen an Anlage !!!

Für USB

Data Interface

Realtime recorded data file

**Format of the
Binary File (.DAT) or
Ascii File (.CSV)**

Definition:

LB= Low Byte,

HB=High-Byte

First the Low-Byte and then the
High-Byte of a channel is recorded

The range of a 12 and 16 bit
system is from 0 to 65535

For 12 bit-systems, the lowest
4 bits are set to 0

Pview
visualisation
program
(part of Software Package
data acquisition)

User specific
analysis program

Excel analysis
programm

Product Key one Channel Radiotelemetry

Type: AW_84H6_Fu_<mod>_<bandwith>_<supply>_<output>

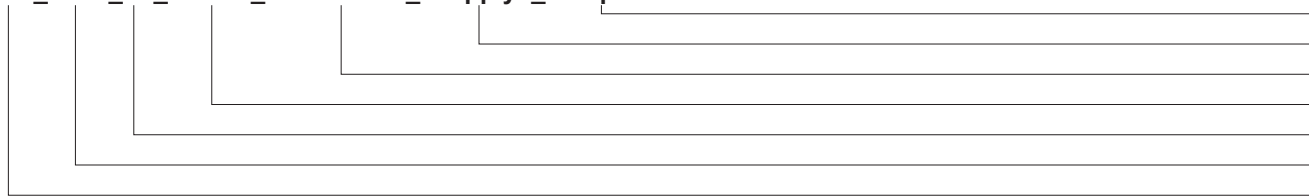

- Output signal (U, I, USB, CAN, TCP)
- Supply
- bandwidth
- Coding (PCM/F)
- Type of system Radio
- Housing type
- Multi channel receiver

Type: SV_Rad_<accuracy>_<temp>_Fu_<mod>_<bandwidth>_<rmc>_<wa>_<TC>_<range>

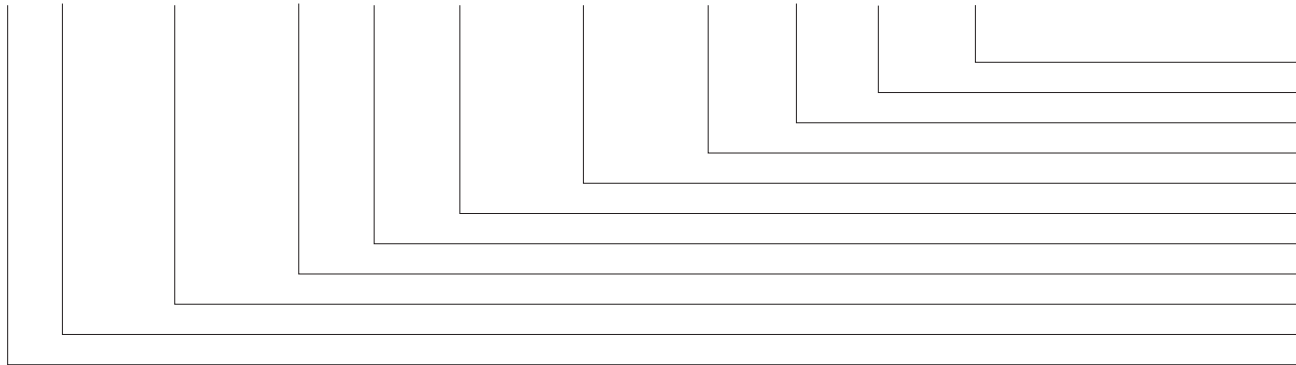

- Range
- Sensor type (SG,TC, PT,..)
- Waterproof/oilproof
- Remote Control
- Bandbreite
- Type of signal transmission
- Type of systemRadio
- Temperature range
- Accuracy
- Housing type
- Multi channel signal amplifier

Not all items are always used

Product Key Multichannel Radiotelemetry

Type: MAW_84H6_<channels>_<sys>_<mod>_<samplerate>_<supply>_<output>_<RPM>

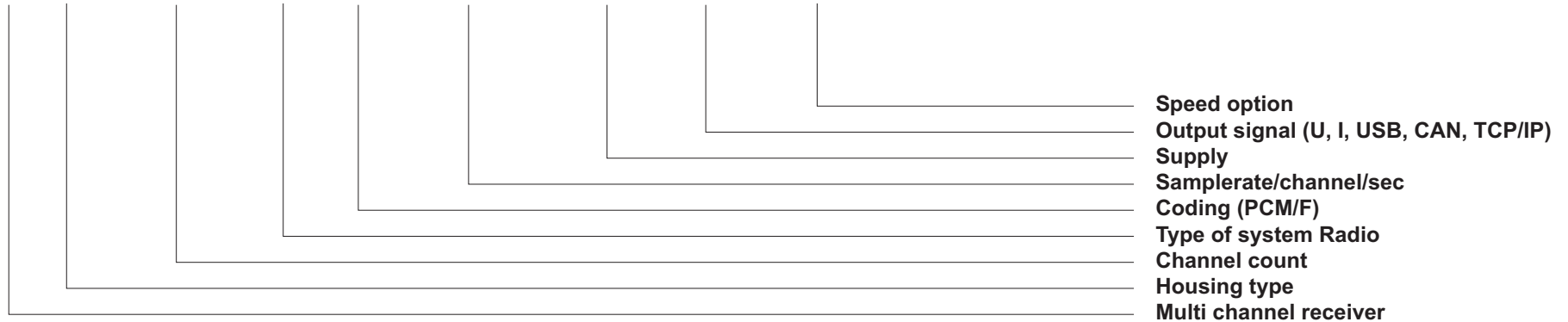

Type: MSV_Rad_<channels>_<accuracy>_<temp>_<Freq>_<sys>_<mod>_<samplerate>_<rmc>_<wa>_<TC>_<range>

