

FACTS

- Hollow shaft Ø: max. 40 mm
- Outer Ø: 90 mm
- Length: 40 mm

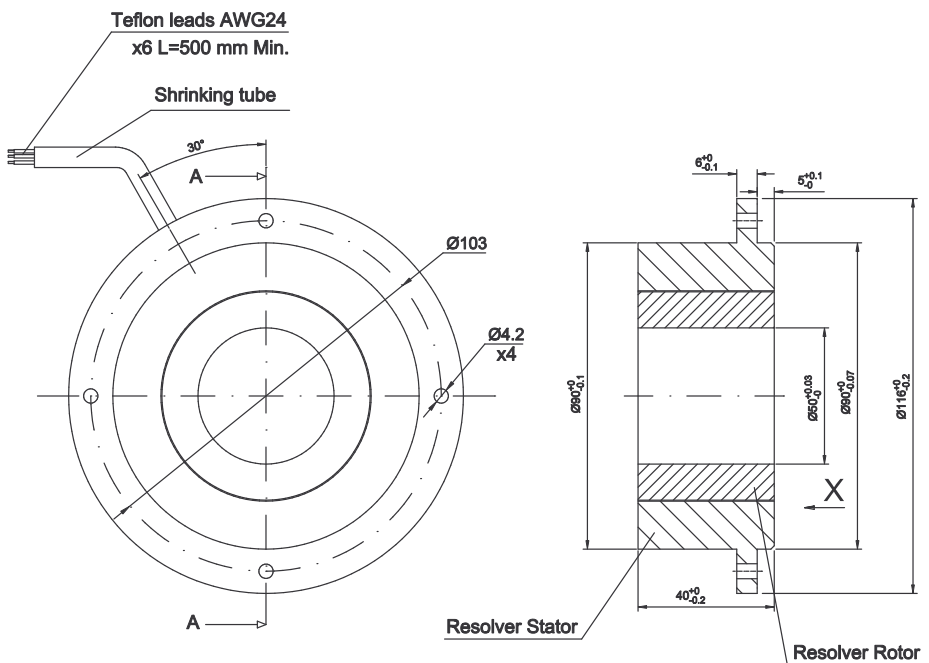
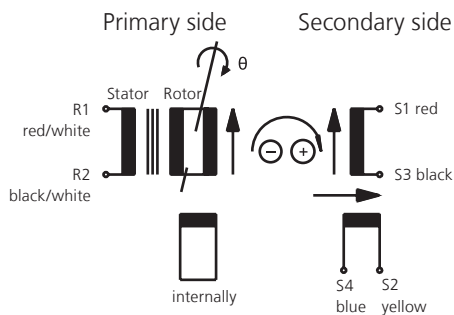

Input: $E(R1-R2) = E \cdot \sin(\cos)$
 Output: $E(S1-S3) = TR \cdot E(R1-R2) \cdot \cos \theta$
 $E(S2-S4) = TR \cdot E(R1-R2) \cdot \sin \theta$
 TR = Transformation ratio

Positive counting direction:
 Rotor cw as viewed (X →)

SELECTION GUIDE FOR ELECTRICAL DATA

	RE-35-1-V05	RE35-3-V01
Primary side	R1 - R2	R1 - R2
Pole Pairs	1	3
Transformation ratio	0,5 ± 10%	0,5 ± 10%
Input voltage	7 V	7 V
Input frequency	5 kHz	5 kHz
Phase shift	+4° ± 3°	+5° ± 3°
Input current (typ.)	48 mA	30 mA
Null voltage	max. 30 mV	max. 30 mV
Accuracy spread	20'	6'
Operating temperature	-55 °C ... +155 °C (-67 °F ... +311 °F)	-55 °C ... +155 °C (-67 °F ... +311 °F)
Hi-pot housing/winding	min. 500 V _{AC}	min. 500 V _{AC}
Hi-pot winding/winding	min. 250 V _{AC}	min. 250 V _{AC}
Rotor/Stator	Completely impregnated	Completely impregnated