

Parts List

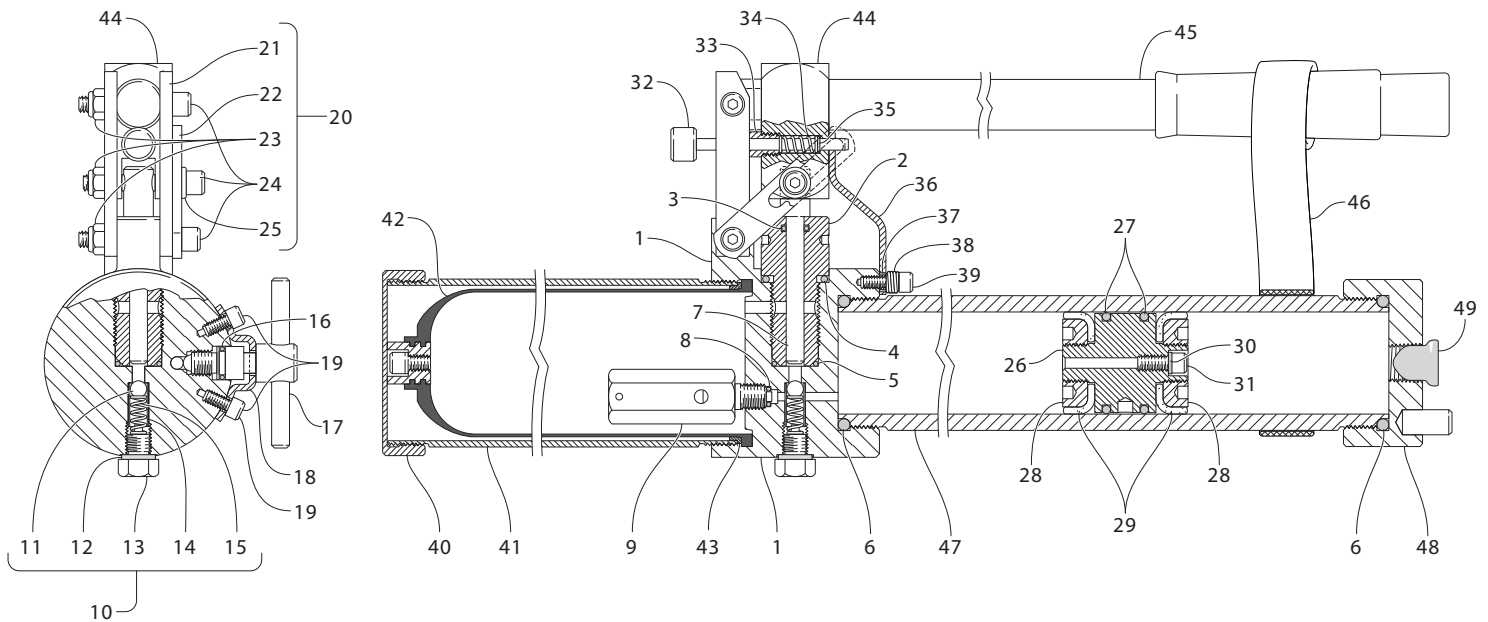

Body Assembly 10780

Key	Description	Part No.
1	Body	10782
2	Cylinder	★ ◎ ○ 10784
3	"O" Ring (Plunger)	★ ◎ ※ * 10842
4	"O" Ring (Cylinder Upper)	★ ◎ ※ * 10788
5	"O" Ring (Cylinder Lower)	★ ◎ ※ * 10626
6	"O" Ring (Grease Barrel)	★ ◎ ※ * 10811
7	Plunger	★ ◎ ○ 10785
8	"O" Ring (Internal Relief Valve)	★ ◎ ※ * 10807
9	Internal Relief Valve (bulletin 99-190)	◎ 10864
10	Check Valve Assembly ▲	★ ◎ 10790
11	▲ Ball	* 10904
12	▲ Gasket	* 10791
13	▲ Check Valve Screw	10789
14	▲ Filter Screen	* 10793
15	▲ Spring	10792
16	"O" Ring (By-Pass Valve)	★ ◎ ※ * 10048
17	By-Pass Valve	10795
18	Stem Retainer	10808
19	Cap Screw (2 Required)	10798

Link Assembly

20	Link Assembly	10781
21	Link (2 Required)	10777
22	Link Stop	11063

Link Assembly (continued)

Key	Description	Part No.
23	Lock Nut (3 Required)	10778
24	Stripper Bolt (3 Required)	10779
25	Washer	11064

Piston Assembly 10810

26	Piston	10815
27	"O" Ring (Piston) (2 Required)	★ ◎ ※ * ◆ 10818
28	Washer Nut (2 Required)	10819
29	Leather Cup (2 Required)	★ ◎ ※ ◆ 10821
30	Copper Gasket	★ ◎ ※ 10817
31	Cap Screw	◎ 10816

The Piston Assembly (part 10810) has an integral bleeder cap screw with a copper gasket. The bleeder assembly facilitates easy bleeding to assure there's no air entrapment.

Latch Assembly 10830

32	Stem & Knob Assembly	10835
33	Latch Screw	10833
34	Latch Spring, Internal	10837
35	Retaining Ring	10839
36	Latch Arm	10831
37	Latch Sleeve	10832
38	Latch Spring, External	10843
39	Cap Screw	10838

General

Key	Description	Part No.
40	Fluid Bag Barrel Cap	10823
41	Fluid Bag Barrel	10822
42	Fluid Bag / Bleeder Assembly	★ ◎ 10820
43	Fluid Bag Seal Ring	◎ 10828
44	Fulcrum Assembly	10772
45	Handle	10776
46	Handle Strap	11339
47	Grease Barrel	10961
48	Grease Barrel Cap	10813
49	Protective Plug (for Grease Barrel Cap)	10568
	Cylinder Spanner Wrench	○ 10895

DUALCO Hydraulic Fluid

1 - Pint Can	★ ◎	10829
4 - oz. Can (Included with Hydraulic Grease Gun)	○	10895
1 - Quart Bottle		11019
1 - Gallon Can		10912

Repair & Maintenance Kits

★	Repair Kit, Minor	10295
◎	Repair Kit, Major	10840
※	"O" Ring Kit	11055
*	Seal Kit	11065
○	Cylinder Repair Kit	11484
◆	Piston Seal Kit	11589