

REMOTE POWER CONTROLLER (RPC)



Single Pole
• 28 VDC

Electronic Current Sensing

The electronic over current sensing of these devices offer several advantages over the bi-metal sensing RCCB. Trip current levels can be closely controlled, for better protection of sensitive loads, trip times are faster, and both can be customized for specific applications. Other advantages included less heat buildup, and higher current capabilities in the same small package.

Use as a Relay, Circuit Breaker, Or Both

RPCs, like RCCBs, combine the best attributes of a circuit breaker and a relay. Automatically protects the wires and the load device during circuit/load breakdown, but allows the flight deck control of the load during normal operation.

Weight and Cost Savings

In distributed-load applications, RPCs are a more efficient power distribution solution promoting cost and weight savings through the elimination of long runs of heavy cables associated with the conventional relay - flight deck circuit protector method. Control of the RPC requires only one #22 AWG control wire from the ICU (model #1500-053-05) on the flight deck to the RPC.

PERFORMANCE DATA

Rupture Levels	2500 A (28V _{DC})
Endurance (Resistive)	50,000 Cycles
Endurance (Inductive and Motor)	25,000 cycles
Endurance (Lamp)	No Rating
Mechanical Life	100,000 cycles
Dielectric Strength	Sea Level - VRMS .2-3 seconds: Coil to Case - 1250 initial, 1,000 After Life, All other Points 1,800 Initial, 1350 After Life 50,000 Ft. - VRMS 1 Minute: Coil to Case 500 Initial & After Life. All other Points 700 Initial & After Life
Insulation Resistance	1100 Megaohms initial, 50 Megohms after Life, MIL-STD-202, method 302, test condition B
Thermal Temperature Range	-55°C to 85°C (-67°F to 185°F).
Vibration	Sinusoidal 5 to 10 Hz: 0.08 DA; 10 TO 55 Hz: 0.06 DA; 55 to 2000 Hz: 10G's
Shock	50G's. (1/2 sine, 10-12 ms)
Altitude	50,000 Ft. Maximum
EMI Requirements	MIL-STD-461, Requirements CS114 and RE102 over the frequency range of 14 KHz to 400 MHz and RE102 limits for Aircraft and Space Systems
Moisture Resistance	MIL-STD-202, method 106
Salt Spray Resistance	MIL-STD-202, method 101, Condition B
Sand and Dust Resistance	MIL-STD-202, method 110, Condition A
Fungus Resistance	MIL-HDBK-454, Guideline 4
Explosion Proof	MIL-STD-202, method 109
Weight (Standard)	425.017 grams (0.937 lbs.)

OVERLOAD DATA

% Rated Current	Trip in Seconds -55°C to +85°C
100%	No Trip
125%	45 Sec. Trip
200%	0.22 Sec. Trip
400%	0.095 Sec. Trip

ORDERING INFORMATION

Single Pole Single Throw (Double Break Contacts)

AMPERE RATING	SAFRAN P/N		Rated Contact Load (Amperes) 28VDC		
125	SM600BA125A1	125	125	125	5
150	SM600BA150A1	150	150	150	5
175	SM600BA175A1	175	150	175	5
200	SM600BA200A1	200	150	175	5

Notes:

- One auxiliary contact included on each unit
- Contact Business Unit on Alternate Amperages, Trip Times, Control Configurations, Grounding, Auxiliary Switches, Mounting Systems, etc.

Engineering Data

Approximate Dimensions - 1 Pole

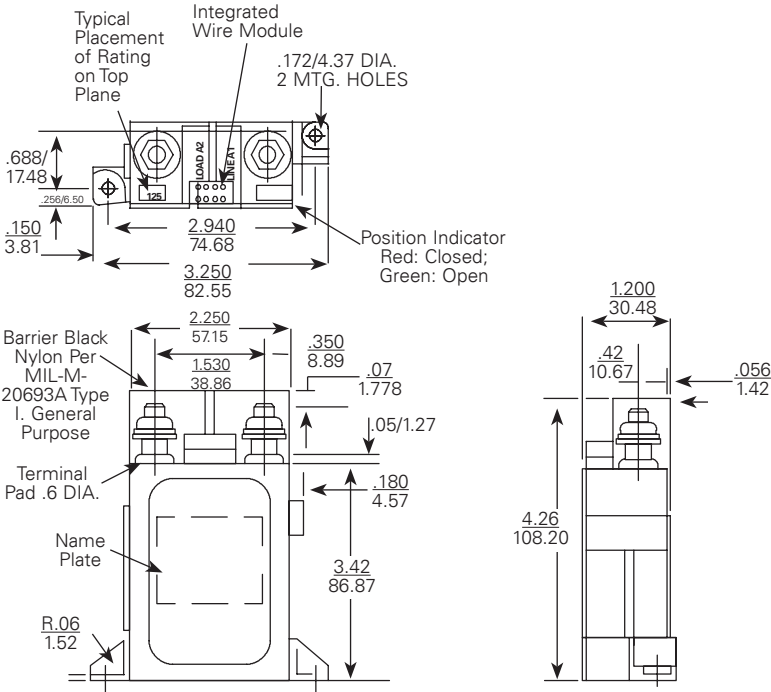

Typical Wiring Diagram

Approximate Dimensions

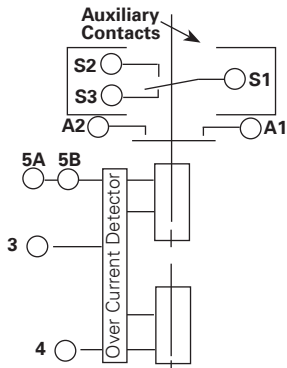
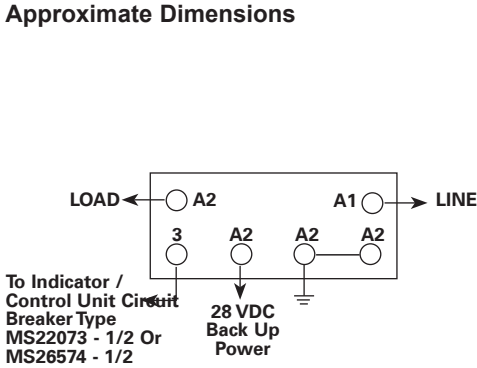

Module: Integrated wire termination. Terminals will accept PIN contact per M39029/1 - 101. Use insertion/extraction tool M81969/14 - 02.

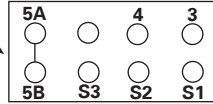

COIL OPERATE CURRENT/SET AND TRIP TIME

Nominal System Voltage	I/C Set Current @ Nom. Voltage (milliamp)	Set Coil Current @Nom Voltage Pulse	MAX. Set Time			*/I/CU. Trip Current Nominal		
			Nominal Voltage @ Room Temp	Most Adverse Condition-Min. Voltage 71°C Ambient	71°C and Nominal Voltage	-54°C and Nominal Voltage	Room Temp and Nominal Voltage	Max. Standby Current (milliamp)
28 VDC (18 Volts Min)	2	3.7 Amp	20 Millisec	35 Millisec	1.76 Amp	1.25 Amp	1.89 Amp	30

* MAX I/CU. LINE IMPEDANCE 7.5 Ohms

CURRENT DECREASES W/TIME SO THAT I²t >= 2