

ELECTRIC ACTUATOR SA SERIES

- Designed for small quarter-turn applications. This actuator can also automate valves requiring up to 270-degrees rotation.
- Engineered to be lightweight and compact for greater versatility.
- The unique housing design allows various options to be installed without the additional cost of an external enclosure.
- 4-LED lights are located inside the high impact dome indicator. When the actuator reaches the full open or full close position, the dome lights will illuminate and allow added visibility over a greater distance or in low light areas.
- To help protect the components and extend the actuator's life, a 5-watt anti-condensation heater is included as standard.
- Included with the end of travel motor switches are two additional dry-contacts for auxiliary indication.
- A thermal protector is provided to protect the motor from over heating.
- The worm gear drive eliminates the possibility of back drive and the need for motor brakes.
- Designed for mounting in any orientation.
- In case of a power loss, the manual over-ride is provided for positioning the valve.
- 3 ISO mounting pads are provided for greater flexibility.



SA005/SA009 SA005L/SA009L

PERFORMANCE

Model	Output Torque		Operating Time (90°)				Motor Class (W)				Rated Current (A)				Duty Cycle		Number of Handle Turns	Weight kg		
			1 Phase(AC)		DC		1 Phase(AC)		DC		1 Phase(AC)		DC							
	Kg.m	N.m	60Hz	50Hz	12V	24V	24V	110V	220V	12V	24V	24V	110V	220V	12V	24V			S2 (min)	S4 (%)
SA005	5	50	14	17	11	10	15	6	6	6	15	1.8	0.35	0.23	3.2	1.8	15	50	6	2.8
SA005L	5	50	14	17	11	10	15	6	6	6	15	1.8	0.35	0.23	3.2	1.8	15	50	6	3.2
SA009	9	90	26	32	25	22	15	6	6	6	15	2.1	0.35	0.25	3.4	2.1	15	30	4.5	2.8
SA009L	9	90	26	32	25	22	15	6	6	6	15	2.1	0.35	0.25	3.4	2.1	15	30	4.5	3.2

OPTION

		SA005 /SA009	SA005L /SA009L
P . I . U	Potentiometer Unit (1K-Ohm)		●
C . P . T	Current Position Transmitter Output DC 4-20mA		●
P . C . U	Proportional Control Unit Input : DC 4-20mA, 2-10V, 1-5V Ourput : DC 4-20mA		●
L . C . U	Local Control Unit		●
R . B . P	Rechargeable Battery Pack		●

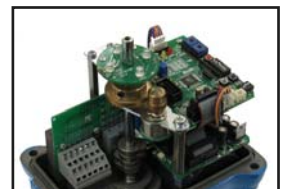
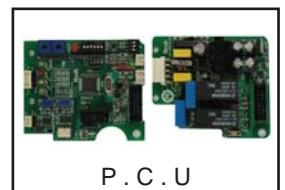

STANDARD SPECIFICATION

Indicator	Dome type (LED light inside)	Enclosure	Weatherproof enclosure IP67 Nema 4 and 6
Ambient temperature	-20°C to 70°C	Power supply	AC 110/230V 1PH ±10% 50/60Hz, DC24(AC24V)
Limit switches	2 Open/Close + Dry contact 2 Open/Close	Travel angle	90°C ± 5° (Extension : upto 270°)
Manual operation	By L-wrench (6mm hexagon)	Self locking	Provided by means of worm gearing
Space heater	5W (110/230VAC, 24VDC)	Conduit entries	Two PF1/2" (Option : M20x1.5, NPT1/2")
Lubrication	Shell Gadus S2 V220 2	Consist of Materials	Steel, Aluminium alloy, bronze
Surface treatment	Anodizing	External coating	Polyester (TGIC-free)

STANDARD WIRING

CLS : Close Limit Switch (250VAC 3A)
 OLS : Open Limit Switch (250VAC 3A)
 ACLS : Aux Close Limit Switch (250VAC 3A)
 AOLS : Aux Open Limit Switch (250VAC 3A)
 TP : Thermal Protector
 RM : Motor Regulation

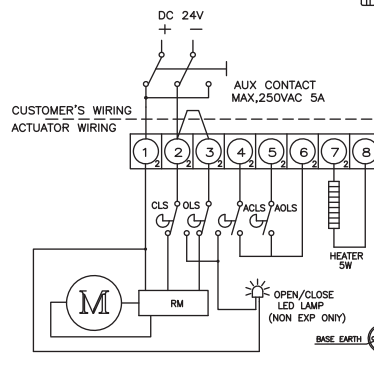
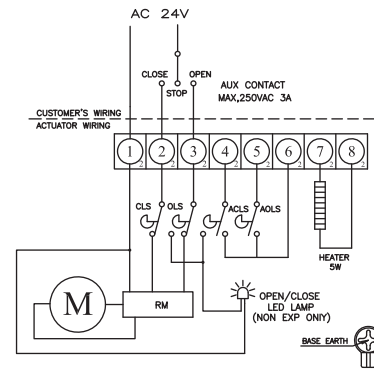
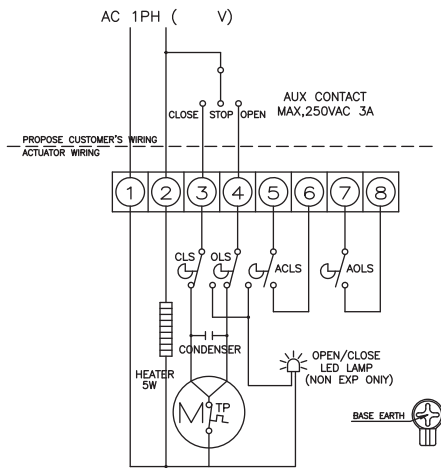

DIMENSION

SA005, SA009	SA005L, SA009L	BASE (OPTION)
<p>168</p> <p>72</p> <p>132</p> <p>80</p> <p>44</p> <p>148</p> <p>MANUAL OPERATION</p>	<p>168</p> <p>72</p> <p>132</p> <p>140</p> <p>44</p> <p>208</p> <p>MANUAL OPERATION</p>	<p>14 DP25</p> <p>BASE B.C.D</p> <p>A: ISO 5211 F03 (∅36 M5TAP DP8) B: ISO 5211 F05 (∅50 M6TAP DP10) C: ISO 5211 F07 (∅70 M8TAP DP13)</p> <p>11 9</p> <p>14 14</p> <p>20 20</p> <p>DRIVE INSERT</p>