

# Safety Couplings Torque Limiters





# CONTENTS

---

## to mount pulleys

### Safety Couplings with ball bearings

KBK/L-P - with Keyway	Page 4
KBK/LL-P - with Keyway	Page 5
KBK/L-K - with Collet Clamp	Page 6
KBK/LL-K - with Collet Clamp	Page 7
KBK/L-I - with Inner Cone	Page 8
KBK/LL-I - with Inner Cone	Page 9
KBK/L-A - with Outer Cone	Page 10
KBK/LL-A - with Outer Cone	Page 11

### Safety Couplings with bush bearings

KBK/CP - with Keyway	Page 12
KBK/CK - with Collet Clamp	Page 13
KBK/CI - with Inner Cone	Page 14
KBK/CA - with Outer Cone	Page 15

## to connect shafts

### Metal Bellows compensate misalignment

KBK/BKK - with 2 Collet Clamps	Page 16
KBK/BKI - with Collet Clamp and Inner Cone	Page 17
KBK/BKA - with Collet Clamp and Outer Cone	Page 18
KBK/BIK - with Inner Cone and Collet Clamp	Page 19
KBK/BII - with 2 Inner Cones	Page 20
KBK/BIA - with Inner Cone and Outer Cone	Page 21
KBK/BAK - with Outer Cone and Collet Clamp	Page 22
KBK/BAI - with Outer Cone and Inner Cone	Page 23
KBK/BAA - with 2 Outer Cones	Page 24

### elastomer inserts compensate misalignment

KBK/EPP - with 2 Keyways	Page 25
KBK/EPK - with Keyway and Collet Clamp	Page 26
KBK/EPI - with Keyway and Inner Cone	Page 27
KBK/EPA - with Keyway and Outer Cone	Page 28
KBK/EKP - with Collet Clamp and Keyway	Page 29
KBK/EKK - with 2 Collet Clamps	Page 30
KBK/EKI - with Collet Clamp and Inner Cone	Page 31
KBK/EKA - with Collet Clamp and Outer Cone	Page 32
KBK/EAP - with Outer Cone and Keyway	Page 33
KBK/EAK - with Outer Cone and Collet Clamp	Page 34
KBK/EAI - with Outer Cone and Inner Cone	Page 35
KBK/EAA - with 2 Outer Cones	Page 36

# to mount Pulleys

## Safety Couplings with ball bearings

### **KBK/L(LL)P10~1400**

with Keyway



### **KBK/L(LL)K2~500**

with Collet Clamp



### **KBK/L(LL)I10~1400**

with Inner Cone



### **KBK/L(LL)A10~1400**

with Outer Cone



## Safety Couplings with bush bearings

### **KBK/CP10~500**

with Keyway



### **KBK/CK2~500**

with Collet Clamp



### **KBK/CI10~500**

with Inner Cone



### **KBK/CA10~500**

with Outer Cone



## Safety Coupling

with Keyway

**optional nickel-plated!** **optional stainless steel**

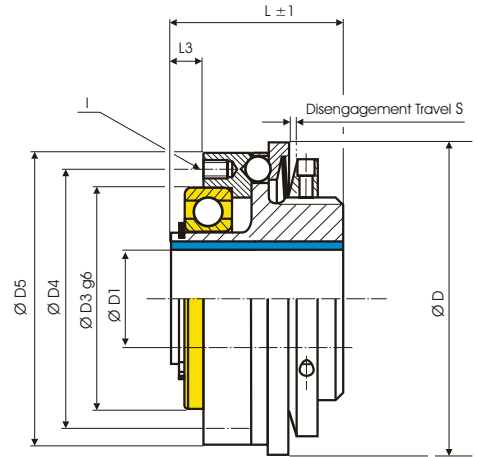

**Order Code: KBK/L - P - 60 - N20H7 - 20Nm - C or D - 2**

Type - Size

Bore D1(H7)

Disengagement Torque

Overload Torque Range

Single Position = C

D= Multi Position Engagement

KBK/L-P-x	Dimensions (mm)									Technical Ratings				
	Ø D	Ø D1	Ø D3	Ø D4	Ø D5	L	L3	S	I	Overload Torque adjustable		Maximum Speed rpm. (1/min)	Mass (kg)	Moment of Inertia J (kg cm <sup>2</sup> )
	Outer Ø	Bore Size (H7) min ~ max				Length			6 x	1 TKN (Nm)	2 TKN (Nm)			
-10	49	6-16	37	42	47	26	5	0.7	M3	3-7	5-10	12000	0.15	0.4
-30	64	10-16	47	53	60	33.5	6	1.2	M4	5-15	10-30	9400	0.45	1.9
-60	79	15-24	62	69	75	45	8	1.2	M5	13-35	20-65	7800	0.83	5.1
-80	94	19-29	68	80	90	46	10	2	M6	15-40	30-80	6400	1.4	12
-150	94	19-29	68	80	90	46	10	2	M6	50-130	65-150	5500	1.4	12
-200	109	20-38	80	90	105	52	10	2	M6	30-90	80-200	5500	1.64	19
-300	119	20-42	90	102	115	58	10	2	M8	60-200	100-300	5000	2.5	38
-500	129	20-50	100	112	125	57	10	2	M8	80-250	200-500	4500	3.8	68
-800	169	30-60	110	125	165	80	15	2	M12	260-600	500-900	3500	11	318
-1400	169	30-60	110	125	165	80	15	2	M12	450-900	800-1400	3500	11	318

Temperature Range: -30°C ~ 120°C

## Safety Coupling

with Keyway

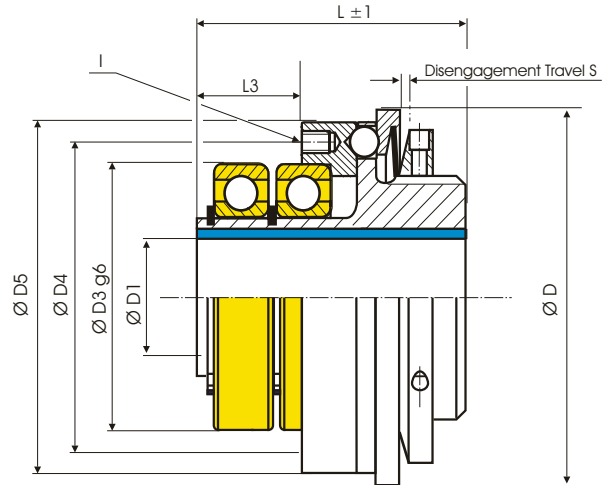

**Order Code: KBK/LL - P - 60 - N20H7 - 20Nm - C or D - 2**

Type - Size

Bore D1 (H7)

Disengagement Torque

Overload Torque Range

Single Position = C ← → D = Multi Position Engagement

KBK/LL-P-x	Dimensions (mm)									Technical Ratings				
	Ø D	Ø D1	Ø D3	Ø D4	Ø D5	L	L3	S	I	Overload Torque adjustable		Maximum Speed rpm. (1/min)	Mass (kg)	Moment of Inertia J (kg cm <sup>2</sup> )
	Outer Ø	Bore Size (H7) min ~ max				Length			6 x	1 TKN (Nm)	2 TKN (Nm)			
-10	49	6-16	37	42	47	36	15	0.7	M3	3-7	5-10	12000	0.18	0.4
-30	64	10-16	47	53	60	47	20	1.2	M4	5-15	10-30	9400	0.53	2.2
-60	79	15-24	62	69	75	62	26	1.2	M5	13-35	20-65	7800	0.98	6.0
-80	94	19-29	68	80	90	62	27	2	M6	15-40	30-80	6400	1.7	14
-150	94	19-29	68	80	90	62	27	2	M6	50-130	65-150	5500	1.7	14
-200	109	20-38	80	90	105	68	28	2	M6	30-90	80-200	5500	1.9	23
-300	119	20-42	90	102	115	78	31	2	M8	60-200	100-300	5000	3.0	44
-500	129	20-50	100	112	125	77	31	2	M8	80-250	200-500	4500	4.5	80
-800	169	30-60	110	125	165	103	38	2	M12	260-600	500-900	3500	13	376
-1400	169	30-60	110	125	165	103	38	2	M12	450-900	800-1400	3500	13	376

Temperature Range: -30°C ~ 120°C

## Safety Coupling

with Collet Clamp

optional  
nickel-  
plated!

optional  
stainless  
steel

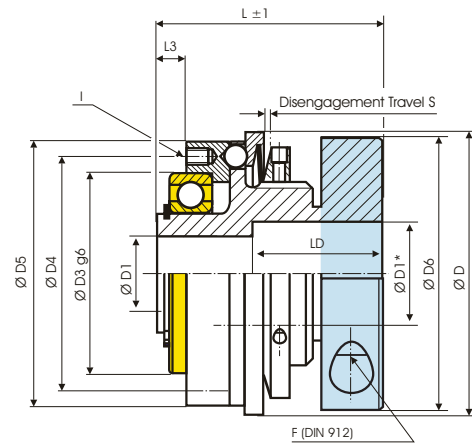

**Order Code: KBK/L - K - 60 - 20H7 - 20Nm - C or D - 2**

Type - Size

Bore D1(H7)

Disengagement  
Torque

Overload  
Torque Range

Single Position = C

D = Multi Position Engagement

KBK/L-x	Dimensions (mm)											Technical Ratings				
	Ø D	Ø D1	Ø D3	Ø D4	Ø D5	Ø D6	L	L3	S	I	F	Overload Torque adjustable		Maximum Speed rpm. (1/min)	Mass (kg)	Moment of Inertia J (kg cm <sup>2</sup> )
	Outer Ø	Bore Size (H7) min ~ max								6 x	Screw (DIN 912) T <sub>A</sub> (Nm)	1 TKN (Nm)	2 TKN (Nm)			
-2	29	3-8	19	21	25	25	28	3	0.7	M2	M3 2	0.2-1.5	0.5-2	13200	0.06	0.05
-4.5	36	6-13	26	28	32	32.5	30	4	0.7	M2	M4 3.5	1-3	3-6	12300	0.11	0.20
-7	49	6-16	37	42	47	40.5	36	5	0.7	M3	M4 4.5	1-4	3-7	12000	0.18	0.4
-10	49	6-16	37	42	47	40.5	36	5	0.7	M3	M4 5.1	3-7	5-10	12000	0.18	0.4
-30	64	10-20	47	53	60	56	52.5	6	1.2	M4	M6 15	5-15	10-30	9400	0.59	2.4
-60	79	12-28	62	69	75	66	73	8	1.2	M5	M8 36	13-35	20-65	7800	1.05	6.4
-80	94	14-35	68	80	90	82	67	10	2	M6	M10 72	15-40	30-80	6400	2.4	21
-150	94	14-35	68	80	90	82	67	10	2	M6	M10 84	50-130	65-150	5500	2.4	21
-200	109	22-41	80	90	105	90	79	10	2	M6	M12 125	30-90	80-200	5500	2.9	35
-300	119	30-50	90	102	115	110	84	10	2	M8	M12 145	60-200	150-300	5000	4.4	66
-500	129	35-56	100	112	125	122	95	10	2	M8	M12 145	80-250	200-500	4500	6.4	113

⊗ Bore > Ø D1 and ≤ D1\* only possible over LD

⊗ Keyway acc. DIN 6885 optional

⊗ Temperature Range: -30°C ~ 120°C

Size	2	4.5	7	10	30	60	80	150	200	300	500
D1*	11	X	20	20	26	31	38	38	X	57	62
LD	15	X	20	20	28	38	34	34	X	42	56

## Safety Coupling

with Collet Clamp and 2 Ball Bearings

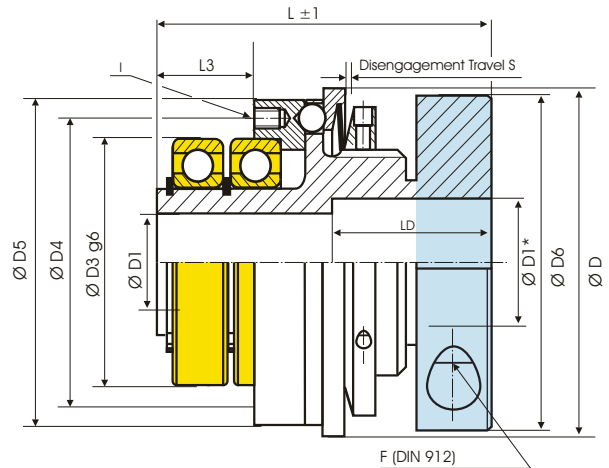
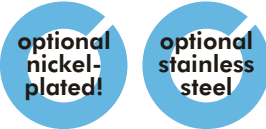

**Order Code: KBK/LL - K - 60 - 20H7 - 20Nm - C or D - 2**

Type - Size

Bore D1(H7)

Disengagement Torque

Overload Torque Range

Single Position = C

D = Multi Position Engagement

KBK/LL-x	Dimensions (mm)											Technical Ratings				
	Ø D	Ø D1	Ø D3	Ø D4	Ø D5	Ø D6	L	L3	S	I	F	Overload Torque adjustable		Maximum Speed rpm. (1/min)	Mass (kg)	Moment of Inertia J (kg cm <sup>2</sup> )
	Outer Ø	Bore Size (H7) min ~ max							6 x	Screw (DIN 912) T <sub>A</sub> (Nm)	1 TKN (Nm)	2 TKN (Nm)				
-2	29	3-8	19	21	25	25	34	7	0.7	M2	M3 2	0.2-1.5	0.5-2	13200	0.07	0.06
-4.5	36	6-13	26	28	32	32.5	37	9	0.7	M2	M4 3.5	1-3	3-6	12300	0.13	0.22
-7	49	6-16	37	42	47	40.5	46	15	0.7	M3	M4 4.5	1-4	3-7	12000	0.21	0.5
-10	49	6-16	37	42	47	40.5	46	15	0.7	M3	M4 5.1	3-7	5-10	12000	0.21	0.5
-30	64	10-20	47	53	60	56	66	20	1.2	M4	M6 15	5-15	10-30	9400	0.67	2.8
-60	79	12-28	62	69	75	66	90	26	1.2	M5	M8 36	13-35	20-65	7800	1.2	7.3
-80	94	14-35	68	80	90	82	83	27	2	M6	M10 72	15-40	30-80	6400	2.7	23
-150	94	14-35	68	80	90	82	83	27	2	M6	M10 84	50-130	65-150	5500	2.7	23
-200	109	22-41	80	90	105	90	96	28	2	M6	M12 125	30-90	80-200	5500	3.3	39
-300	119	30-50	90	102	115	110	104	31	2	M8	M12 145	60-200	150-300	5000	4.9	73
-500	129	35-56	100	112	125	122	113	31	2	M8	M12 145	80-250	200-500	4500	7.0	125

⊙ Bore > Ø D1 and ≤ D1\* only possible over LD

⊙ Keyway acc. DIN 6885 optional

⊙ Temperature Range: -30°C ~ 120°C

Size	2	4.5	7	10	30	60	80	150	200	300	500
D1*	11	X	20	20	26	31	38	38	X	57	62
LD	15	X	20	20	28	38	34	34	X	42	56

## Safety Couplings

with Inner Cone

**optional nickel-plated!** **optional stainless steel**

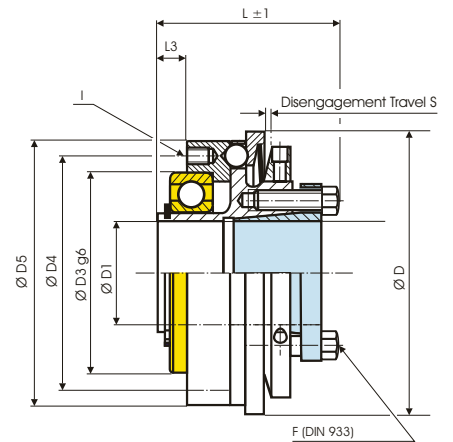

**Order Code: KBK/L - I - 60 - 20H7 - 20Nm - C or D - 2**

Type - Size

Bore D1 (H7)

Disengagement Torque

Overload Torque Range

Single Position = C

D = Multi Position Engagement

KBK/L-I-X	Dimensions (mm)										Technical Ratings				
	Ø D	Ø D1	Ø D3	Ø D4	Ø D5	L	L3	S	I	F	Overload Torque adjustable		Maximum Speed rpm. (1/min)	Mass (kg)	Moment of Inertia J (kg cm <sup>2</sup> )
	Outer Ø	Bore Size (H7) min ~ max				Length			6 x	Screw (DIN 933) T <sub>A</sub> (Nm)	1 TKN (Nm)	2 TKN (Nm)			
-10	49	6-14	37	42	47	36	5	0.7	M3	M3 2.1	3-7	5-10	12000	0.18	0.4
-30	64	12-20	47	53	60	45	6	1.2	M4	M5 6	5-15	10-30	9400	0.54	2.2
-60	79	15-25	62	69	75	58	8	1.2	M5	M6 8.5	13-35	20-65	7800	1.01	6.2
-80	94	20-35	68	80	90	60	10	2	M6	M6 14	15-40	30-80	6400	1.72	15
-150	94	20-35	68	80	90	60	10	2	M6	M6 14	50-130	65-150	5500	1.72	15
-200	109	20-40	80	90	105	66	10	2	M6	M6 14	30-90	80-200	5500	2	24
-300	119	25-45	90	102	115	75	10	2	M8	M8 20	60-200	150-300	5000	3.3	49
-500	129	35-55	100	112	125	75	10	2	M8	M8 26	80-250	200-500	4500	4.7	83
-800	169	50-70	110	125	165	110	15	2	M12	M16 45	260-600	500-900	3500	13.1	380
-1400	169	50-70	110	125	165	110	15	2	M12	M16 80	450-900	800-1400	3500	13.2	385

☉ Keyway acc. DIN 6885 optional

☉ Temperature Range: -30°C ~ 120°C



## Safety Coupling

with Inner Cone and 2 ball bearings

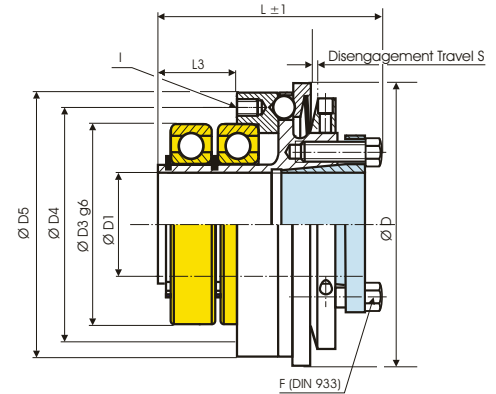

**Order Code: KBK/LL - I - 60 - 20H7 - 20Nm - C or D - 2**

Type - Size

Bore D1(H7)

Disengagement Torque

Overload Torque Range

Single Position = C ←      → D = Multi Position Engagement

KBK/LL-x	Dimensions (mm)										Technical Ratings				
	Ø D	Ø D1	Ø D3	Ø D4	Ø D5	L	L3	S	I	F	Overload Torque adjustable		Maximum Speed rpm. (1/min)	Mass (kg)	Moment of Inertia J (kg cm <sup>2</sup> )
	Outer Ø	Bore Size (H7) min ~ max				Length			6 x	Screw (DIN 933) T <sub>A</sub> (Nm)	1 TKN (Nm)	2 TKN (Nm)			
-10	49	6-14	37	42	47	46	15	0.7	M3	M3 2.1	3-7	5-10	12000	0.21	0.5
-30	64	12-20	47	53	60	58	20	1.2	M4	M5 6	5-15	10-30	9400	0.62	2.6
-60	79	15-25	62	69	75	75	26	1.2	M5	M6 8.5	13-35	20-65	7800	1.16	7.1
-80	94	20-35	68	80	90	76	27	2	M6	M6 14	15-40	30-80	6400	1.97	17
-150	94	20-35	68	80	90	76	27	2	M6	M6 14	50-130	65-150	5500	1.97	17
-200	109	20-40	80	90	105	85	28	2	M6	M6 14	30-90	80-200	5500	2.30	27
-300	119	25-45	90	102	115	95	31	2	M8	M8 20	60-200	150-300	5000	3.7	56
-500	129	35-55	100	112	125	95	31	2	M8	M8 26	80-250	200-500	4500	5.3	95
-800	169	50-70	110	125	165	133	38	2	M12	M16 45	260-600	500-900	3500	15	438
-1400	169	50-70	110	125	165	133	38	2	M12	M16 80	450-900	800-1400	3500	15	438

☉ Keyway acc. DIN 6885 optional

☉ Temperature Range: -30°C ~ 120°C

## Safety Coupling

with Outer Cone

**optional nickel-plated!** **optional stainless steel**

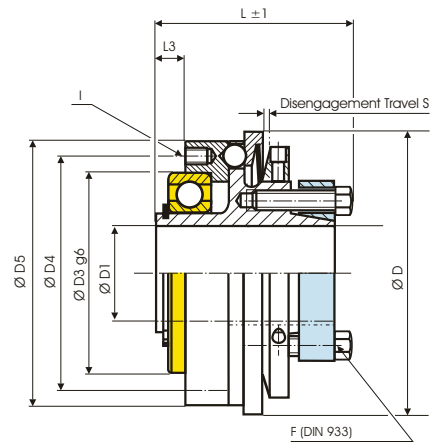

**Order Code: KBK/L - A - 60 - 20H7 - 20Nm - C or D - 2**

Type - Size

Bore D1 (H7)

Disengagement Torque

Overload Torque Range

Single Position = C

D = Multi Position Engagement

KBK/LA-x	Dimensions (mm)										Technical Ratings				
	Ø D	Ø D1	Ø D3	Ø D4	Ø D5	L	L3	S	I	F	Overload Torque adjustable		Maximum Speed rpm. (1/min)	Mass (kg)	Moment of Inertia J (kg cm <sup>2</sup> )
	Outer Ø	Bore Size (H7) min ~ max				Length			6 x	Screw (DIN 933) T <sub>A</sub> (Nm)	1 TKN (Nm)	2 TKN (Nm)			
-10	49	5-14	37	42	47	37.5	5	0.7	M3	M3 2.1	3-7	5-10	12000	0.18	0.4
-30	64	12-20	47	53	60	48	6	1.2	M4	M5 5.9	5-15	10-30	9400	0.54	2.2
-60	79	15-32	62	69	75	66	8	1.2	M5	M5 8.7	13-35	20-65	7800	1.01	6.2
-80	94	20-35	68	80	90	68.5	10	2	M6	M6 15	15-40	30-80	6400	1.72	15
-150	94	20-35	68	80	90	68.5	10	2	M6	M6 15	50-130	65-150	5500	1.72	15
-200	109	20-42	80	90	105	74.5	10	2	M6	M6 15	30-90	80-200	5500	2	24
-300	119	25-50	90	102	115	83.5	10	2	M8	M8 25	60-200	150-300	5000	3.3	49
-500	129	35-55	100	112	125	89	10	2	M8	M8 36	80-250	200-500	4500	4.7	83
-800	169	50-70	110	125	165	118	15	2	M12	M12 85	260-600	500-900	3500	13.1	380
-1400	169	50-70	110	125	165	118	15	2	M12	M12 115	450-900	800-1400	3500	13.2	385

☉ Keyway acc. DIN 6885 optional

☉ Temperature Range: -30°C ~ 120°C

## Safety Coupling

with Outer Cone and 2 ball bearings

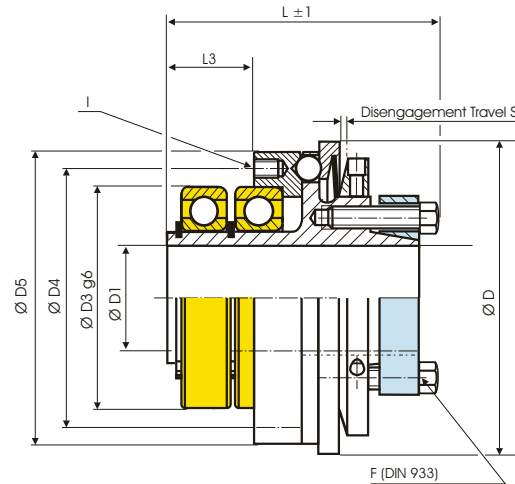
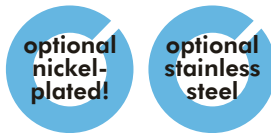

**Order Code: KBK/LL - A - 60 - 20H7 - 20Nm - C or D - 2**

Type - Size

Bore D1(H7)

Disengagement Torque

Overload Torque Range

Single Position = C

D = Multi Position Engagement

KBK/LLA-x	Dimensions (mm)										Technical Ratings				
	Ø D	Ø D1	Ø D3	Ø D4	Ø D5	L	L3	S	I	F	Overload Torque adjustable		Maximum Speed rpm. (1/min)	Mass (kg)	Moment of Inertia J (kg cm <sup>2</sup> )
	Outer Ø	Bore Size (H7) min ~ max				Length			6 x	Screw (DIN 933) T <sub>A</sub> (Nm)	1 TKN (Nm)	2 TKN (Nm)			
-10	49	5-14	37	42	47	47.5	15	0.7	M3	M3 2.1	3-7	5-10	12000	0.21	0.5
-30	64	12-20	47	53	60	61.5	20	1.2	M4	M5 5.9	5-15	10-30	9400	0.62	2.6
-60	79	15-32	62	69	75	83	26	1.2	M5	M5 8.7	13-35	20-65	7800	1.16	7.1
-80	94	20-35	68	80	90	84.5	27	2	M6	M6 15	15-40	30-80	6400	1.97	17
-150	94	20-35	68	80	90	84.5	27	2	M6	M6 15	50-130	65-150	5500	1.97	17
-200	109	20-42	80	90	105	93.5	28	2	M6	M6 15	30-90	80-200	5500	2.30	27
-300	119	25-50	90	102	115	103.5	31	2	M8	M8 25	60-200	150-300	5000	3.7	56
-500	129	35-55	100	112	125	109	31	2	M8	M8 36	80-250	200-500	4500	5.3	95
-800	169	50-70	110	125	165	141	38	2	M12	M12 85	260-600	500-900	3500	15	438
-1400	169	50-70	110	125	165	141	38	2	M12	M12 115	450-900	800-1400	3500	15	438

☉ Keyway acc. DIN 6885 optional

☉ Temperature Range: -30°C ~ 120°C

## Safety Coupling

with Keyway

optional nickel-plated!  
optional stainless steel

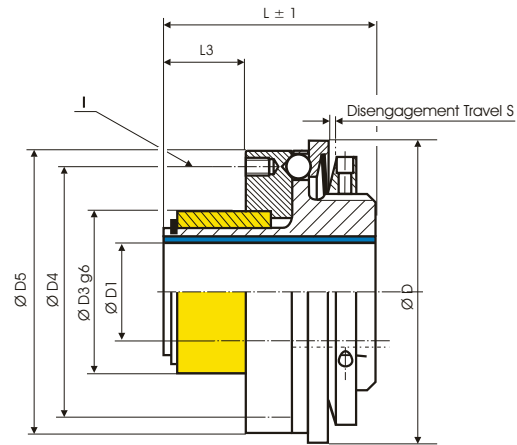

**Order Code: KBK/CP - 60 - N20H7 - 20Nm - C or D - 2**

Type - Size

Bore D1(H7)

Disengagement Torque

Overload Torque Range

Single Position = C

D = Multi Position Engagement

KBK/CP-x	Dimensions (mm)									Technical Ratings				
	Ø D	Ø D1	Ø D3	Ø D4	Ø D5	L	L3	S	I	Overload Torque adjustable		Maximum Speed rpm. (1/min)	Mass (kg)	Moment of Inertia J (kg cm <sup>2</sup> )
	Outer Ø	Bore Size (H7) min ~ max							6 x	1 TKN (Nm)	2 TKN (Nm)			
-10	49	6-10	24	30	47	34	8	0.7	M3	3-7	5-10	12000	0.15	0.35
-30	64	10-14	30	46	60	40	9	1.2	M4	5-15	10-30	9400	0.45	1.9
-60	79	15-19	36	50	75	48	16	1.2	M5	13-35	20-65	7800	0.83	5.1
-80	94	19-30	48	65	90	58	22	2	M6	15-40	30-80	6400	1.4	12
-150	94	19-30	48	65	90	58	22	2	M6	50-130	65-150	5500	1.4	12
-200	109	20-33	52	70	105	63	25	2	M6	30-90	80-200	5500	1.64	19
-300	119	20-38	58	76	115	75	31	2	M8	60-200	150-300	5000	2.5	38
-500	129	20-42	66	110	125	94	33	2	M8	80-250	200-500	4500	3.8	68

Temperature Range: -30°C ~ 120°C

### Safety Coupling

with Collet Clamp

optional nickel-plated!  
optional stainless steel

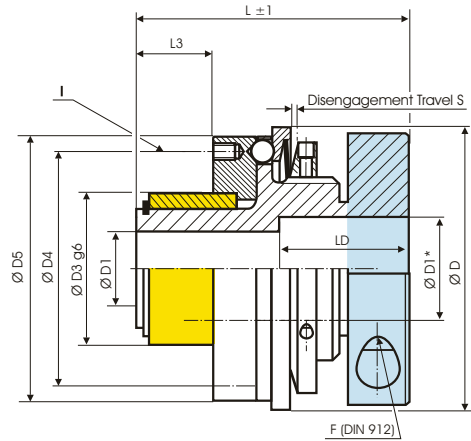

**Order Code: KBK/CK - 60 - 20H7 - 20Nm - C or D - 2**

Type - Size

Bore D1(H7)

Disengagement Torque

Overload Torque Range

Single Position = C

D = Multi Position Engagement

KBK/CK-x	Dimensions (mm)										Technical Ratings				
	Ø D	Ø D1	Ø D3	Ø D4	Ø D5	L	L3	S	I	F	Overload Torque adjustable		Maximum Speed rpm. (1/min)	Mass (kg)	Moment of Inertia J (kg cm <sup>2</sup> )
	Outer Ø	Bore Size (H7) min ~ max							6 x	Screw (DIN 912) T <sub>A</sub> (Nm)	1 TKN (Nm)	2 TKN (Nm)			
-2	29	3-6	14	19	25	35	6	0.7	M2	M3 2	0.2-1.5	0.5-2	13200	0.06	0.05
-4.5	36	6-12	20	26	32	36	7	0.7	M2	M4 3.5	1-3	3-6	12300	0.12	0.20
-7	49	6-16	24	30	47	44	8	0.7	M3	M4 5.1	1-4	3-7	12000	0.18	0.4
-10	49	6-16	24	30	47	44	8	0.7	M3	M4 5.1	3-7	5-10	12000	0.18	0.4
-30	64	10-20	30	46	60	59	9	1.2	M4	M6 15	5-15	10-30	9400	0.59	2.4
-60	79	12-25	36	50	75	76	16	1.2	M5	M8 36	13-35	20-65	7800	1.05	6.4
-80	94	14-35	48	65	90	79	22	2	M6	M10 72	15-40	30-80	6400	2.4	21
-150	94	14-35	48	65	90	79	22	2	M6	M10 72	50-130	65-150	5500	2.4	21
-200	109	22-40	52	70	105	91	25	2	M6	M12 125	30-90	80-200	5500	3.0	35
-300	119	30-46	58	76	115	101	31	2	M8	M12 145	60-200	150-300	5000	4.4	66
-500	129	35-50	66	110	125	134	33	2	M8	M12 145	80-250	200-500	4500	6.4	113

⊗ Bore > Ø D1 and ≤ D1\* only possible over LD

⊗ Keyway acc. DIN 6885 optional

⊗ Temperature Range: -30°C ~ 120°C

Size	2	4.5	7	10	30	60	80	150	200	300	500
D1*	11	X	20	20	26	31	38	38	X	57	62
LD	15	X	20	20	28	38	34	34	X	42	56

## Safety Coupling

with Inner Cone

**optional nickel-plated!** **optional stainless steel**

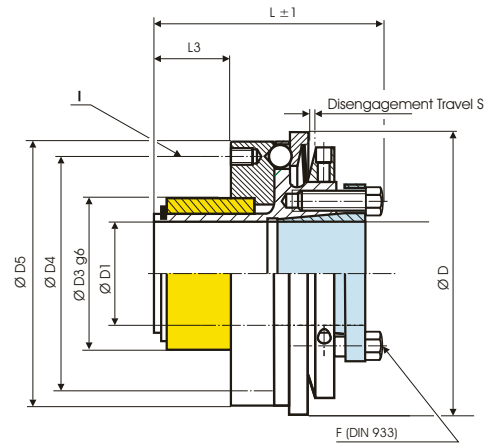

**Order Code: KBK/CI - 60 - 20H7 - 20Nm - C or D - 2**

Type - Size

Bore D1(H7)

Disengagement Torque

Overload Torque Range

Single Position = C

D = Multi Position Engagement

KBK/CI-x	Dimensions (mm)										Technical Ratings				
	Ø D	Ø D1	Ø D3	Ø D4	Ø D5	L	L3	S	I	F	Overload Torque adjustable		Maximum Speed rpm. (1/min)	Mass (kg)	Moment of Inertia J (kg cm <sup>2</sup> )
	Outer Ø	Bore Sizes (H7) min ~ max						6 x	Screw (DIN 933) TA (Nm)	1 TKN (Nm)	2 TKN (Nm)				
-10	49	6-14	24	30	47	44	8	0.7	M3	M3 2.1	3-7	5-10	12000	0.18	0.4
-30	64	12-20	30	46	60	51	9	1.2	M4	M5 6	5-15	10-30	9400	0.54	2.2
-60	79	15-25	36	50	75	61	16	1.2	M5	M6 8.5	13-35	20-65	7800	1	6.2
-80	94	20-35	48	65	90	72	22	2	M6	M6 14	15-40	30-80	6400	1.7	15
-150	94	20-35	48	65	90	72	22	2	M6	M6 14	50-130	65-150	5500	1.7	15
-200	109	20-40	52	70	105	77	25	2	M6	M6 14	30-90	80-200	5500	2	24
-300	119	25-46	58	76	115	93	31	2	M8	M8 20	60-200	150-300	5000	3.3	49
-500	129	35-50	66	110	125	112	33	2	M8	M8 26	80-250	200-500	4500	4.7	83

Keyway acc. DIN 6885 optional

Temperature Range: -30°C ~ 120°C

## Safety Coupling

with Outer Cone

optional  
nickel-plated!

optional  
stainless steel

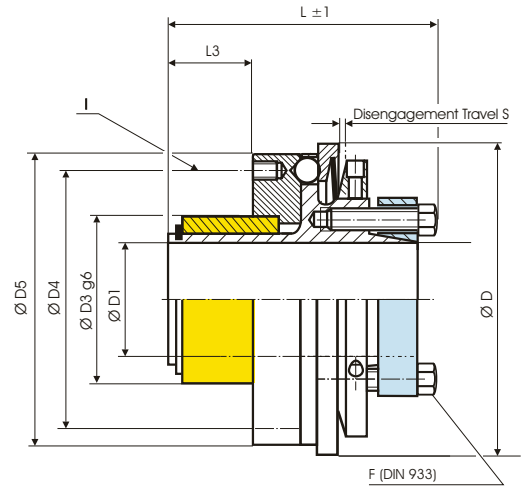

**Order Code: KBK/CA - 60 - 20H7 - 20Nm - C or D - 2**

Type - Size

Bore D1 (H7)

Disengagement  
Torque

Overload  
Torque Range

Single Position = C

D = Multi Position Engagement

KBK/CA-x	Dimensions (mm)										Technical Ratings				
	Ø D	Ø D1	Ø D3	Ø D4	Ø D5	L	L3	S	I	F	Overload Torque adjustable		Maximum Speed rpm. (1/min)	Mass (kg)	Moment of Inertia J (kg cm <sup>2</sup> )
	Outer Ø	Bore Sizes (H7) min ~ max							6 x	Screw (DIN 933) T <sub>A</sub> (Nm)	1 TKN (Nm)	2 TKN (Nm)			
-10	49	5-14	24	30	47	46	8	0.7	M3	M3 2.1	3-7	5-10	12000	0.18	0.4
-30	64	12-20	30	46	60	54	9	1.2	M4	M5 5.9	5-15	10-30	9400	0.53	2.2
-60	79	15-25	36	50	75	69	16	1.2	M5	M5 8.7	13-35	20-65	7800	1	6.1
-80	94	20-35	48	65	90	80	22	2	M6	M6 15	15-40	30-80	6400	1.8	16
-150	94	20-35	48	65	90	80	22	2	M6	M6 15	50-130	65-150	5500	1.8	16
-200	109	20-40	52	70	105	85	25	2	M6	M6 15	30-90	80-200	5500	2	24
-300	119	25-46	58	76	115	101	31	2	M8	M8 25	60-200	150-300	5000	3.2	47
-500	129	35-50	66	110	125	126	33	2	M8	M8 36	80-250	200-500	4500	4.7	84

☉ Keyway acc. DIN 6885 optional

☉ Temperature Range: -30°C ~ 120°C

# to connect shafts

## Safety Couplings with Metal Bellows to compensate Misalignment

### **KBK/BKK 2~500**

with 2 Collet Clamps



### **KBK/BKI10~500**

with Collet Clamp and Inner Cone



### **KBK/BKA10~500**

with Collet Clamp and Outer Cone



### **KBK/BIK10~500**

with Inner Cone and Collet Clamp



### **KBK/BI10~1400**

with 2 Inner Cones



### **KBK/BIA10~1400**

with Inner Cone and Outer Cone



### **KBK/BAK10~500**

with Outer Cone and Collet Clamp



### **KBK/BAI10~1400**

with Outer Cone and Inner Cone



### **KBK/BAA10~1400**

with 2 Outer Cones





## Safety Coupling

with 2 Collet Clamps

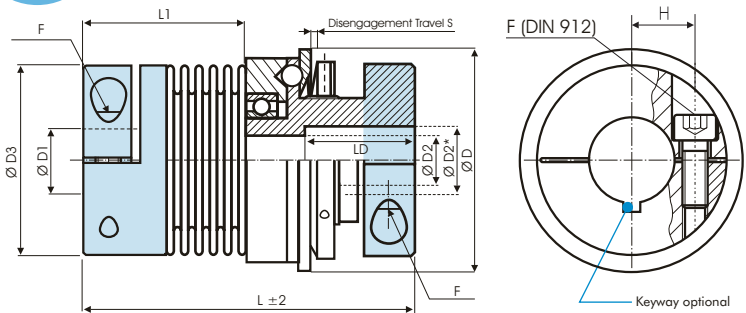
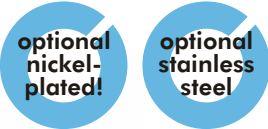

**Order Code: KBK/BKK - 60 - 105 - 16H7 - 14H7 - 20Nm - C or D - 1**

Type / Size

Length

Ø D2 (H7)

Ø D2 (H7)

Disengagement Torque

Overload Torque Range

C= Single Position D= Multi Position Engagement

KBK/BKK-x	Dimensions (mm)									Technical Ratings																		
	Ø D	L	Ø D1	Ø D2	Ø D3	H	F	L1	S	Maximum Speed	Mass	Moment of Inertia	Overload Torque adjustable		Spring Stiffness			Misalignment										
	Outer Ø	Length	Bore Size (H7) min ~ max	Bore Size (H7) min ~ max	Hub-dia-meter		Screw (DIN 912) T <sub>A</sub> (Nm)			rpm. (1/min)	(kg)	J (kg cm <sup>2</sup> )	1 T <sub>KN</sub> (Nm)	2 T <sub>KN</sub> (Nm)	torsional x10 <sup>3</sup> C <sub>T</sub> (Nm/rad)	radial C <sub>R</sub> (N/mm)	axial C <sub>A</sub> (N/mm)	radial ΔKr (mm)	axial ΔKa (mm)	angular ΔKw (°)								
-2	29	46	3	3	25	9	M3	21	0.7	13200	0.08	0.06	0.2	0.5	1.5	67	12	0.15	0.3	1.5								
		52	14	8			27	2													1.3	21	11	0.20	0.4	1.5		
		56	14	8			31	2													1.0	11	9	0.25	0.5	2		
-4.5	36	57	6	6	32.5	12	M4	27	0.7	12300	0.16	0.26	1	3	6.5	168	32	0.1	0.3	1.5								
		65	16	13			3.5	36													4.2	41	20	0.2	0.5	2		
-7	49	65	6	6	40	15.5	M4	34	0.7	11690	0.25	0.58	1	3	8.1	120	27	0.15	0.4	1.5								
		75	25	16			5.1	43													6.8	29	17	0.3	0.6	2		
-10	49	65	6	6	40	15.5	M4	34	0.7	11690	0.25	0.6	3	5	8.1	120	27	0.15	0.4	1.5								
		75	25	16			5.1	43													6.8	29	17	0.3	0.6	2		
-30	64	85	10	10	56	20	M6	40.5	1.2	9540	0.77	3.2	5	10	38	720	50	0.15	0.6	1.5								
		94	30	20			15	48.5													28	225	28	0.25	1	2		
-60	79	105	12	12	66	23	M8	50	1.2	8180	1.34	8.2	12	20	75	1150	90	0.15	0.6	1.5								
		115	32	28			36	60													50	340	50	0.25	1	2		
-80	94	113	14	14	82	28	M10	57.5	2	6220	3.52	31	15	30	128	1200	80	0.2	0.5	1.5								
		125	42	35			72	68.5													75	400	50	0.25	0.8	2		
-150	94	113	19	14	82	28	M10	57.5	2	6220	3.52	31	50	65	155	2020	145	0.2	0.5	1.5								
		125	42	35			72	68.5													130	150	105	595	85	0.25	0.8	2
-200	109	125	22	22	90	31	M12	63	2	5720	4.45	53	30	80	175	2500	147	0.2	0.5	1.5								
		138	45	41			125	75													90	200	116	460	82	0.25	0.8	2
-300	119	140	30	30	110	39	M12	67	2	5200	6.47	97	60	150	502	6300	280	0.2	0.5	1.5								
		150	60	50			125	78													200	300	285	1400	145	0.25	0.8	2
-500	129	158	35	35	122	42	M12	70	2	4470	9.22	164	80	200	690	7790	100	0.2	0.5	1.5								
		170	70	56			125	81													250	500	320	970	85	0.25	1	2

Material: Bellows: stainless steel  
Collet Clamp (Size 2 to Size 60): Aluminum  
Collet Clamp (Size 80 to Size 500): Steel

Temperature Range: -30°C ~ 120°C

Keyway acc. DIN 6885 optional

Bore > Ø D1 and ≤ D1\* only possible over LD

Size	2	4.5	7	10	30	60	80	150	200	300	500
D2*	11	X	20	20	26	31	38	38	X	57	62
LD	15	X	20	20	28	38	34	34	X	42	56

## Safety Coupling

with Collet Clamp and Inner Cone

optional  
nickel-  
plated!

optional  
stainless  
steel

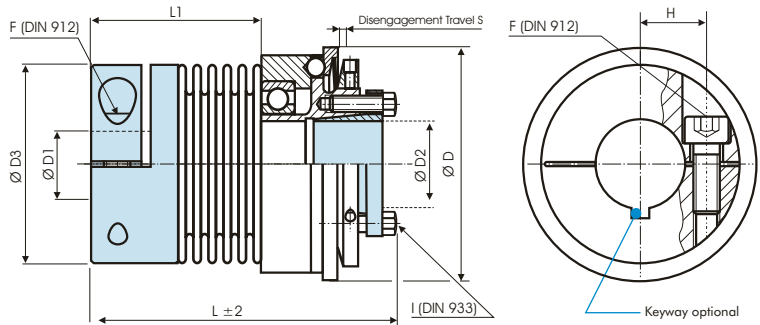

**Order Code: KBK/BKI - 60 - 100 - 16H7 - 14H7 - 20Nm - C or D - 1**

Type / Size

Length

Ø D2 (H7)

Ø D2 (H7)

Disengagement  
Torque

Overload  
Torque Range

C= Single Position D= Multi Position Engagement

KBK/BKI-x	Dimensions (mm)										Technical Ratings										
	Ø D	L	Ø D1	Ø D2	Ø D3	H	F	L1	I	S	Maximum Speed rpm. (1/min)	Mass (kg)	Moment of Inertia J (kg cm <sup>2</sup> )	Overload Torque adjustable		Spring Stiffness			Misalignment		
	Outer Ø	Length	Bore Size (H7) min max	Bore Size (H7) min max	Hub- dia- meter	Screw (DIN 912) TA (Nm)	Screw (DIN 933) TA (Nm)	T <sub>KN</sub> (Nm)	T <sub>KN</sub> (Nm)	torsional x10 <sup>3</sup> C <sub>T</sub> (Nm/rad)				radial C <sub>R</sub> (N/mm)	axial C <sub>A</sub> (N/mm)	radial ΔK <sub>r</sub> (mm)	axial ΔK <sub>a</sub> (mm)	angular ΔK <sub>w</sub> (°)			
<b>-10</b>	49	65	6	6	40	15.5	M4	34	M3	0.7	11690	0.24	0.6	3	5	8.1	120	27	0.15	0.4	1.5
		75	25	14			5.1	43	2.1					7	10						
<b>-30</b>	64	77.5	10	12	56	20	M6	40.5	M5	1.2	9540	0.72	3.0	5	10	38	720	50	0.15	0.6	1.5
		86.5	30	20			15	48.5	6					15	30						
<b>-60</b>	79	90	12	15	66	23	M8	50	M6	1.2	8180	1.3	7.9	12	20	75	1150	90	0.15	0.6	1.5
		100	32	25			36	60	8.5					35	60						
<b>-80</b>	94	106	14	20	82	28	M10	57.5	M6	2	6220	2.84	25	15	30	128	1200	80	0.2	0.5	1.5
		118	42	35			72	68.5	14					40	80						
<b>-150</b>	94	106	19	20	82	28	M10	57.5	M6	2	6220	2.84	25	50	65	155	2020	145	0.2	0.5	1.5
		118	42	35			72	68.5	14					130	150						
<b>-200</b>	109	113	22	20	90	31	M12	63	M6	2	5720	3.48	41	30	80	175	2500	147	0.2	0.5	1.5
		126	45	40			125	75	14					90	200						
<b>-300</b>	119	131	30	25	110	39	M12	67	M8	2	5200	5.35	80	60	150	502	6300	280	0.2	0.5	1.5
		141	60	45			125	78	18					200	300						
<b>-500</b>	129	140	35	35	122	42	M12	70	M8	2	4470	7.54	134	80	200	690	7790	100	0.2	0.5	1.5
		151	70	55			125	81	26					250	500						

Material: Bellows: Stainless Steel

Collet Clamp (Size 10 to Size 60): Aluminium

Collet Clamp (Size 80 to Size 500): Steel

Inner Cone: Steel

Keyway acc. DIN 6885 optional

Temperature Range: -30°C ~ 120°C

## Safety Coupling

with Collet Clamp and Outer Cone

optional  
nickel-  
plated!

optional  
stainless  
steel

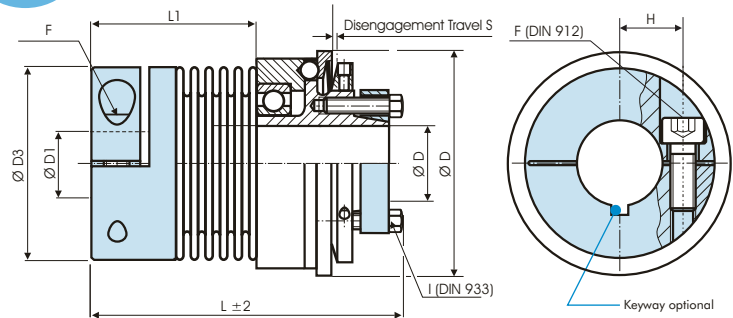

**Order Code: KBK/BKA - 60 - 108 - 16H7 - 14H7 - 20Nm - C or D - 1**

Type / Size

Length

Ø D2 (H7)

Ø D2 (H7)

Disengagement  
Torque

Overload  
Torque Range

C = Single Position D = Multi Position Engagement

KBK/BKA-x	Dimensions (mm)										Technical Range										
	Ø D	L	Ø D1	Ø D2	Ø D3	H	F	L1	I	S	Maximum Speed	Mass	Moment of Inertia	Overload Torque adjustable		Spring Stiffness			Misalignment		
	Outer Ø	Length	Bore Size (H7) min max	Bore Size (H7) min max	Hub-diameter		Screw (DIN 912) T <sub>A</sub> (Nm)	Screw (DIN 933) T <sub>A</sub> (Nm)			rpm. (1/min)	(kg)	J (kg cm <sup>2</sup> )	1 T <sub>KN</sub> (Nm)	2 T <sub>KN</sub> (Nm)	torsional x10 <sup>3</sup> C <sub>T</sub> (Nm/rad)	radial C <sub>R</sub> (N/mm)	axial C <sub>A</sub> (N/mm)	radial ΔK <sub>r</sub> (mm)	axial ΔK <sub>a</sub> (mm)	angular ΔK <sub>w</sub> (°)
<b>-10</b>	49	67	6	5	40	15.5	M4	34	M3	0.7	11690	0.24	0.6	3	5	8.1	120	27	0.15	0.4	1.5
		77	25	14			5.1	43	2.1					7	10						
<b>-30</b>	64	81	10	12	56	20	M6	40.5	M5	1.2	9540	0.71	2.9	5	10	38	720	50	0.15	0.6	1.5
		90	30	20			15	48.5	5.9					15	30						
<b>-60</b>	79	98	12	15	66	23	M8	50	M5	1.2	8180	1.29	7.9	12	20	75	1150	90	0.15	0.6	1.5
		108	32	32			36	60	8.7					35	60						
<b>-80</b>	94	115	14	20	82	28	M10	57.5	M6	2	6220	2.89	25	15	30	128	1200	80	0.2	0.5	1.5
		127	42	35			72	68.5	15					40	80						
<b>-150</b>	94	115	19	20	82	28	M10	57.5	M6	2	6220	2.89	25	50	65	155	2020	145	0.2	0.5	1.5
		126	42	35			72	68.5	15					130	150						
<b>-200</b>	109	122	22	20	90	31	M12	63	M6	2	5720	3.5	42	30	80	175	2500	147	0.2	0.5	1.5
		135	45	42			125	75	15					90	200						
<b>-300</b>	119	140	30	25	110	39	M12	67	M8	2	5200	5.23	79	60	150	502	6300	280	0.2	0.5	1.5
		150	60	50			125	78	25					200	300						
<b>-500</b>	129	154	35	35	122	42	M12	70	M8	2	4470	7.5	135	80	200	690	7790	100	0.2	0.5	1.5
		165	75	55			125	81	36					250	500						

Material: Bellows: Stainless Steel

Collet Clamp (Size 10 to Size 60): Aluminium

Collet Clamp (Size 80 to Size 500): Steel

Outer Cone: Steel

Keyway acc. DIN 6885 optional

Temperature Range: -30°C ~ 120°C

### Safety Coupling

with Inner Cone and Collet Clamp

optional  
nickel-  
plated!

optional  
stainless  
steel

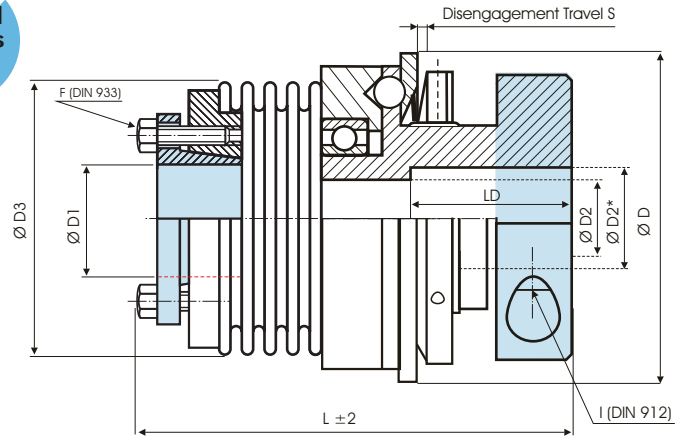

Order Code: **KBK/BIK - 60 - 107 - 15H7 - 18H7 - 20Nm - C or D - 2**

Type / Size

Length

Ø D2 (H7)

Ø D2 (H7)

Disengagement  
Torque

Overload  
Torque Range

C = Single Position D = Multi Position Engagement

KBK/BIK-x	Dimensions (mm)								Technical Ratings										
	ØD	L	ØD1	ØD2	ØD3	F	I	S	Maximum Speed rpm. (1/min)	Mass (kg)	Moment of Inertia J (kg cm <sup>2</sup> )	Overload Torque adjustable		Spring Stiffness			Misalignment		
	Outer Ø	Length	Bore Size (H7) min~max	Bore Size (H7) min~max	Screw (DIN 933) T <sub>A</sub> (Nm)	Screw (DIN 912) T <sub>A</sub> (Nm)	1 T <sub>KN</sub> (Nm)	2 T <sub>KN</sub> (Nm)				torsional ×10 <sup>3</sup> C <sub>T</sub> (Nm/rad)	radial C <sub>R</sub> (N/mm)	axial C <sub>A</sub> (N/mm)	radial ΔK <sub>r</sub> (mm)	axial ΔK <sub>a</sub> (mm)	angular ΔK <sub>w</sub> (°)		
<b>-10</b>	49	68	6-14	6-16	40.5	M3	M4	0.7	11650	0.27	0.6	3-7	5-10	8.1	120	27	0.15	0.4	1.5
		78				2.1	5.1							6.8	29	17	0.3	0.6	2
<b>-30</b>	64	79	12-20	10-20	56	M5	M6	1.2	9540	0.81	3.3	5-15	10-30	38	720	50	0.15	0.6	1.5
		88				6	15							28	225	28	0.25	1	2
<b>-60</b>	79	97	15-25	12-28	66	M6	M8	1.2	8180	1.48	9	12-35	20-60	75	1150	90	0.15	0.6	1.5
		107				8.5	36							50	340	50	0.25	1	2
<b>-80</b>	94	107	20-35	14-35	82	M6	M10	2	6220	3.2	28	15-40	30-80	128	1200	80	0.2	0.5	1.5
		119				14	72							75	400	50	0.25	0.8	2
<b>-150</b>	94	107	20-35	14-35	82	M6	M10	2	6220	3.2	28	50-130	65-150	155	2020	145	0.2	0.5	1.5
		119				14	72							105	595	85	0.25	0.8	2
<b>-200</b>	109	114	20-40	22-41	90	M6	M12	2	5720	3.9	46	30-90	80-200	175	2500	147	0.2	0.5	1.5
		127				14	125							116	460	82	0.25	0.8	2
<b>-300</b>	119	133	25-50	30-50	110	M8	M12	2	5200	6.1	92	60-200	150-300	502	6300	280	0.2	0.5	1.5
		143				18	125							285	1400	145	0.25	0.8	2
<b>-500</b>	129	147	35-55	35-56	122	M8	M12	2	4470	8.4	150	80-250	200-500	690	7790	100	0.2	0.5	1.5
		158				26	125							320	970	85	0.25		2

Size	2	4.5	7	10	30	60	80	150	200	300	500
D2*	11	X	20	20	26	31	38	38	X	57	62
LD	15	X	20	20	28	38	34	34	X	42	56

Material: Bellows: Stainless Steel

Collet Clamp (Size 10 to Size 60): Aluminium

Collet Clamp (Size 80 to Size 500): Steel

Inner Cone: Steel

Keyway acc. DIN 6885 optional

Temperature Range: -30°C ~ 120°C

Bore > Ø D1 and ≤ D1\* only possible over LD

### Safety Couplings

with 2 Inner Cones

**optional nickel-plated!**  
**optional stainless steel!**

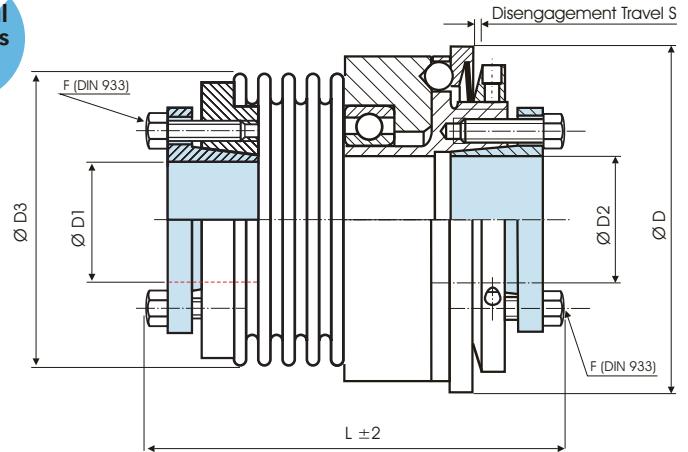

**Order Code: KBK/BII - 60 - 100 - 15H7 - 18H7 - 20Nm - C or D - 2**

Type / Size      Length      Ø D2 (H7)      Ø D2 (H7)      Disengagement Torque      Overload Torque Range  
C = Single Position      D = Multi Position Engagement

KBK/BII-x	Dimensions(mm)							Technical Ratings										
	ØD	L	ØD1	ØD2	ØD3	F	S	Maximum Speed rpm. (1/min)	Mass (kg)	Moment of Inertia J (kg cm <sup>2</sup> )	Overload Torque adjustable		Spring Stiffness			Misalignment		
	Outer Ø	Length	Bore Size (H7) min~max	Bore Size (H7) min~max		Screw (DIN 933) TA (Nm)	1 T <sub>KN</sub> (Nm)				2 T <sub>KN</sub> (Nm)	torsional x10 <sup>3</sup> C <sub>T</sub> (Nm/rad)	radial C <sub>R</sub> (N/mm)	axial C <sub>A</sub> (N/mm)	radial ΔK <sub>r</sub> (mm)	axial ΔK <sub>a</sub> (mm)	angular ΔK <sub>w</sub> (°)	
<b>-10</b>	49	68	6-14	6-14	40.5	M3	0.7	11650	0.27	0.6	3-7	5-10	8.1	120	27	0.15	0.4	1.5
		78				6.8							29	17	0.3	0.6	2	
<b>-30</b>	64	85	12-20	12-20	56	M5	1.2	9540	0.76	3.1	5-15	10-30	38	720	50	0.15	0.6	1.5
		94				28							225	28	0.25	1	2	
<b>-60</b>	79	100	15-25	15-25	66	M6	1.2	8180	1.44	8.8	12-35	20-60	75	1150	90	0.15	0.6	1.5
		110				50							340	50	0.25	1	2	
<b>-80</b>	94	115	20-35	20-35	82	M6	2	6220	2.5	22	15-40	30-80	128	1200	80	0.2	0.5	1.5
		128				75							400	50	0.25	0.8	2	
<b>-150</b>	94	115	20-35	20-35	82	M6	2	6220	2.5	22	50-130	65-150	155	2020	145	0.2	0.5	1.5
		128				105							595	85	0.25	0.8	2	
<b>-200</b>	109	125	20-40	20-40	90	M6	2	5720	2.88	34	30-90	80-200	175	2500	147	0.2	0.5	1.5
		135				116							460	82	0.25	0.8	2	
<b>-300</b>	119	135	25-50	25-45	110	M8	2	5200	5.0	75	60-200	150-300	502	6300	280	0.2	0.5	1.5
		145				285							1400	145	0.25	0.8	2	
<b>-500</b>	129	150	35-55	35-55	122	M8	2	4470	6.73	120	80-250	200-500	690	7790	100	0.2	0.5	1.5
		162				320							970	85	0.25	1	2	
<b>-800</b>	169	235	50-70	50-70	157	M16	2	3350	17.8	518	240-600	500-800	700	500	185	0.2	0.8	1.8
		45				700							500	185	0.2	0.8	1.8	
<b>-1400</b>	169	235	50-70	50-70	157	M16	2	3350	18.0	523	360-1000	900-1400	1270	700	275	0.2	0.8	1.8
		80				1270							700	275	0.2	0.8	1.8	

Material: Bellows: Stainless Steel      Inner Cone: Steel

Keyway acc. DIN 6885 optional

Temperature Range: -30°C ~ 120°C

## Safety Couplings

with Inner Cone and Outer Cone

optional  
nickel-plated!

optional  
stainless steel

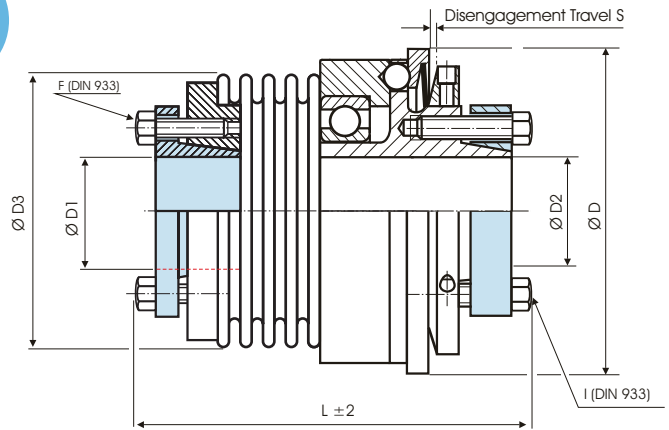

Order Code: **KBK/BIA - 60 - 100 - 15H7 - 18H7 - 20Nm - C or D - 2**

Type / Size

Length

Ø D2 (H7)

Ø D2 (H7)

Disengagement  
Torque

Overload  
Torque Range

C = Single Position D = Multi Position Engagement

KBK/BIA-x	Dimensions (mm)								Technical Ratings										
	ØD	L	ØD1	ØD2	ØD3	F	S	I	Maximum Speed rpm. (1/min)	Mass (kg)	Moment of Inertia J (kg cm <sup>2</sup> )	Overload Torque adjustable		Spring Stiffness			Misalignment		
	Outer Ø	Length	Bore Size (H7) min~max	Bore Size (H7) min~max	Screw (DIN 933) TA (Nm)	Screw (DIN 933) TA (Nm)	1 TKN (Nm)	2 TKN (Nm)				torsional x10 <sup>3</sup> CT (Nm/rad)	radial CR (N/mm)	axial CA (N/mm)	radial ΔKr (mm)	axial ΔKa (mm)	angular ΔKw (°)		
<b>-10</b>	49	69	6-14	5-14	40.5	M3	0.7	M3	11650	0.27	0.6	3-7	5-10	8.1	120	27	0.15	0.4	1.5
		79				2.1		2.1						6.8	29	17	0.3	0.6	2
<b>-30</b>	64	74	12-20	12-20	56	M5	1.2	M5	9540	0.75	3.1	5-15	10-30	38	720	50	0.15	0.6	1.5
		83				6		5.9						28	225	28	0.25	1	2
<b>-60</b>	79	89	15-25	15-32	66	M6	1.2	M5	8180	1.43	8.8	12-35	20-60	75	1150	90	0.15	0.6	1.5
		100				8.5		8.7						50	340	50	0.25	1	2
<b>-80</b>	94	108	20-35	20-35	82	M6	2	M6	6220	2.5	22	15-40	30-80	128	1200	80	0.2	0.5	1.5
		120				14		15						75	400	50	0.25	0.8	2
<b>-150</b>	94	108	20-35	20-35	82	M6	2	M6	6220	2.5	22	50-130	65-150	155	2020	145	0.2	0.5	1.5
		120				14		15						105	595	85	0.25	0.8	2
<b>-200</b>	109	110	20-40	20-42	90	M6	2	M6	5720	2.9	34	30-90	80-200	175	2500	147	0.2	0.5	1.5
		123				14		15						116	460	82	0.25	0.8	2
<b>-300</b>	119	132	25-50	25-50	110	M8	2	M8	5200	4.9	73	60-200	150-300	502	6300	280	0.2	0.5	1.5
		143				18		25						285	1400	145	0.25	0.8	2
<b>-500</b>	129	149	35-55	35-55	122	M8	2	M8	4470	6.8	120	80-250	200-500	690	7790	100	0.2	0.5	1.5
		160				26		36						320	970	85	0.25	1	2
<b>-800</b>	169	243	50-70	50-70	157	M16	2	M12	3350	18	516	240-600	500-800	700	500	185	0.2	0.8	1.8
		45				85		700						500	185	0.2	0.8	1.8	
<b>-1400</b>	169	243	50-70	50-70	157	M16	2	M12	3350	18	520	360-1000	900-1400	1270	700	275	0.2	0.8	1.8
		80				115		1270						700	275	0.2	0.8	1.8	

Material: Bellows: Stainless Steel Inner Cone: Steel Outer Cone: Steel

Keyway acc. DIN 6885 optional

Temperature Range: -30°C ~ 120°C

## Safety Couplings

with Outer Cone and Collet Clamp

optional  
nickel-plated!

optional  
stainless steel

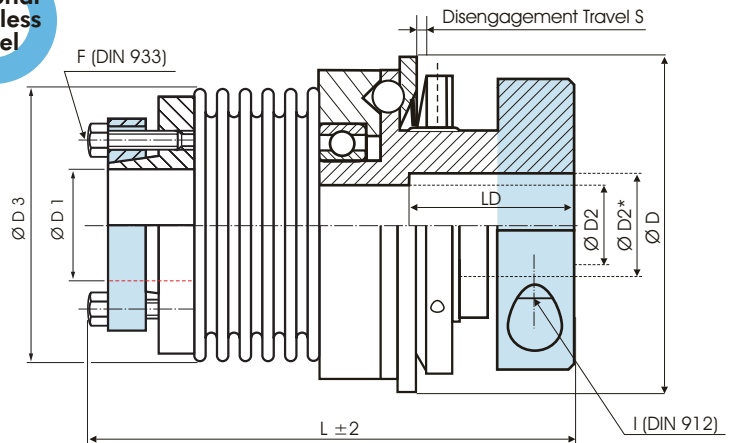

Order Code: **KBK/BAK - 60 - 115 - 15H7 - 18H7 - 20Nm - C or D - 2**

Type / Size

Length

Ø D2 (H7)

Ø D2 (H7)

Disengagement  
Torque

Overload  
Torque Range

C = Single Position D = Multi Position Engagement

KBK/BAK-x	Dimensions (mm)								Technical Ratings										
	ØD	L	ØD1	ØD2	ØD3	F	S	I	Maximum Speed rpm. (1/min)	Mass (kg)	Moment of Inertia J (kg cm <sup>2</sup> )	Overload Torque adjustable		Spring Stiffness			Misalignment		
	Outer Ø	Length	Bore Size (H7) von-bis	Bore Size (H7) von-bis		Screw (DIN 933) T <sub>A</sub> (Nm)	Screw (DIN 912) T <sub>A</sub> (Nm)	1 T <sub>KN</sub> (Nm)				2 T <sub>KN</sub> (Nm)	torsional x10 <sup>3</sup> C <sub>T</sub> (Nm/rad)	radial C <sub>R</sub> (N/mm)	axial C <sub>A</sub> (N/mm)	radial ΔK <sub>r</sub> (mm)	axial ΔK <sub>a</sub> (mm)	angular ΔK <sub>w</sub> (°)	
<b>-10</b>	49	65	5-14	6-16	40.5	M3	0.7	M4	11650	0.27	0.6	3-7	5-10	8.1	120	27	0.15	0.4	1.5
		74				2.1		5.1						6.8	29	17	0.3	0.6	2
<b>-30</b>	64	82	12-20	10-20	56	M5	1.2	M6	9540	0.80	3.3	5-15	10-30	38	720	50	0.15	0.6	1.5
						92		5.9						15	28	225	28	0.25	1
<b>-60</b>	79	104	15-32	12-28	66	M5	1.2	M8	8180	1.46	8.9	12-35	20-60	75	1150	90	0.15	0.6	1.5
						115		8.7						36	50	340	50	0.25	1
<b>-80</b>	94	115	20-35	14-35	82	M6	2	M10	6220	3.3	29	15-40	30-80	128	1200	80	0.2	0.5	1.5
						127		15						72	75	400	50	0.25	0.8
<b>-150</b>	94	115	20-35	14-35	82	M6	2	M10	6220	3.3	29	50-130	65-150	155	2020	145	0.2	0.5	1.5
						127		15						72	105	595	85	0.25	0.8
<b>-200</b>	109	122	20-42	22-41	90	M6	2	M12	5720	3.9	46	30-90	80-200	175	2500	147	0.2	0.5	1.5
						135		15						125	116	460	82	0.25	0.8
<b>-300</b>	119	141	25-50	30-50	110	M8	2	M12	5200	5.9	88	60-200	150-300	502	6300	280	0.2	0.5	1.5
						152		25						125	285	1400	145	0.25	0.8
<b>-500</b>	129	163	35-55	35-56	122	M8	2	M12	4470	8.5	151	80-250	200-500	690	7790	100	0.2	0.5	1.5
						175		36						125	320	970	85	0.25	1

⊙ Bore > Ø D1 and ≤ D1\* only possible over LD

⊙ Keyway acc. DIN 6885 optional

⊙ Temperature Range: -30°C ~ 120°C

Size	2	4.5	7	10	30	60	80	150	200	300	500
D2*	11	X	20	20	26	31	38	38	X	57	62
LD	15	X	20	20	28	38	34	34	X	42	56

⊙ Material: Bellows: Stainless Steel  
Collet Clamp (Size 10 to Size 60): Aluminium  
Collet Clamp (Size 80 to Size 500): Steel  
Outer Cone: Steel

## Safety Couplings

with Outer Cone and Inner Cone

**optional nickel-plated!**  
**optional stainless steel!**

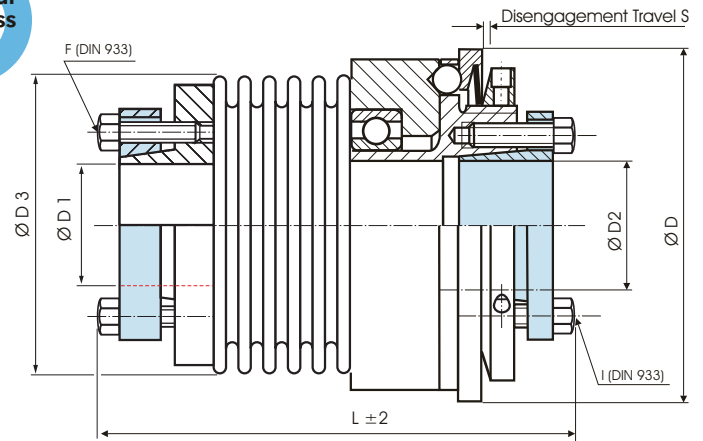

**Order Code: KBK/BAI - 60 - 100 - 15H7 - 18H7 - 20Nm - C or D - 2**

Type / Size

Length

Ø D2 (H7)

Ø D2 (H7)

Disengagement Torque

Overload Torque Range

C = Single Position D = Multi Position Engagement

KBK/BAI-x	Dimensions (mm)								Technical Ratings										
	ØD	L	ØD1	ØD2	ØD3	F	S	I	Maximum Speed rpm. (1/min)	Mass (kg)	Moment of Inertia J (kg cm <sup>2</sup> )	Overload Torque adjustable		Spring Stiffness			Misalignment		
	Outer Ø	Length	Bore Size (H7) von-bis	Bore Size (H7) von-bis		Screw (DIN 933) TA (Nm)	Screw (DIN 933) TA (Nm)	1 T <sub>KN</sub> (Nm)				2 T <sub>KN</sub> (Nm)	torsional ×10 <sup>3</sup> C <sub>T</sub> (Nm/rad)	radial C <sub>R</sub> (N/mm)	axial C <sub>A</sub> (N/mm)	radial ΔK <sub>r</sub> (mm)	axial ΔK <sub>a</sub> (mm)	angular ΔK <sub>w</sub> (°)	
<b>-10</b>	49	65	5-14	6-14	40.5	M3	0.7	M3	11650	0.27	0.6	3-7	5-10	8.1	120	27	0.15	0.4	1.5
		74				2.1		2.1						6.8	29	17	0.3	0.6	2
<b>-30</b>	64	75	12-20	12-20	56	M5	1.2	M5	9540	0.75	3.1	5-15	10-30	38	720	50	0.15	0.6	1.5
		84				5.9		6						28	225	28	0.25	1	2
<b>-60</b>	79	89	15-32	15-25	66	M5	1.2	M6	8180	1.42	8.7	12-35	20-60	75	1150	90	0.15	0.6	1.5
		100				8.7		8.5						50	340	50	0.25	1	2
<b>-80</b>	94	108	20-35	20-35	82	M6	2	M6	6220	2.6	23	15-40	30-80	128	1200	80	0.2	0.5	1.5
		120				15		14						75	400	50	0.25	0.8	2
<b>-150</b>	94	108	20-35	20-35	82	M6	2	M6	6220	2.6	23	50-130	65-150	155	2020	145	0.2	0.5	1.5
		120				15		14						105	595	85	0.25	0.8	2
<b>-200</b>	109	110	20-42	20-40	90	M6	2	M6	5720	2.9	34	30-90	80-200	175	2500	147	0.2	0.5	1.5
		123				15		14						116	460	82	0.25	0.8	2
<b>-300</b>	119	133	25-50	25-45	110	M8	2	M8	5200	4.8	72	60-200	150-300	502	6300	280	0.2	0.5	1.5
		143				25		18						285	1400	145	0.25	0.8	2
<b>-500</b>	129	145	35-55	35-55	122	M8	2	M8	4470	6.8	121	80-250	200-500	690	7790	100	0.2	0.5	1.5
		157				36		26						320	970	85	0.25	1	2
<b>-800</b>	169	242	50-70	50-70	157	M12	2	M16	3350	17.8	515	240-600	500-800	700	500	185	0.2	0.8	1.8
						85		45											
<b>-1400</b>	169	242	50-70	50-70	157	M12	2	M16	3350	17.9	519	360-1000	900-1400	1270	700	275	0.2	0.8	1.8
						115		80											

Material: Bellows: Stainless Steel Hubs: Steel

Keyway acc. DIN 6885 optional

Temperature Range: -30°C ~ 120°C



## Safety Couplings

with 2 Outer Cones

**optional nickel-plated!** **optional stainless steel**

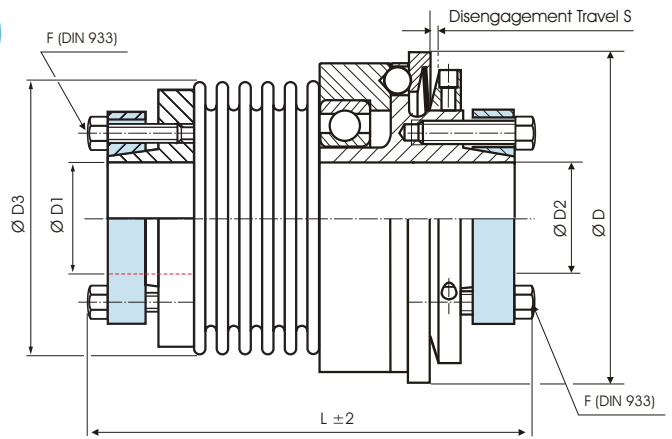

**Order Code: KBK/BAA - 60 - 108 - 15H7 - 18H7 - 20Nm - C or D - 2**

Type / Size      Length      Ø D2 (H7)      Ø D2 (H7)      Disengagement Torque      Overload Torque Range  
 C = Single Position      D = Multi Position Engagement

KBK/BAA-x	Dimensions (mm)							Technical Ratings										
	Outer Ø	Length	Bore Size (H7)		ØD3	F	S	Maximum Speed	Mass	Moment of Inertia J	Overload Torque adjustable		Spring Stiffness			Misalignment		
			min-max	min-max							rpm. (1/min)	(kg)	(kg cm <sup>2</sup> )	1 T <sub>kN</sub> (Nm)	2 T <sub>kN</sub> (Nm)	torsional x10 <sup>3</sup> C <sub>T</sub> (Nm/rad)	radial C <sub>R</sub> (N/mm)	axial C <sub>A</sub> (N/mm)
<b>-10</b>	49	66	5-14	5-14	40.5	M3	0.7	11650	0.27	0.6	3-7	5-10	8.1	120	27	0.15	0.4	1.5
		75											6.8	29	17	0.3	0.6	2
<b>-30</b>	64	78	12-20	12-20	56	M5	1.2	9540	0.74	3.0	5-15	10-30	38	720	50	0.15	0.6	1.5
		87											28	225	28	0.25	1	2
<b>-60</b>	79	97	15-32	15-32	66	M5	1.2	8180	1.41	8.6	12-35	20-60	75	1150	90	0.15	0.6	1.5
		108											50	340	50	0.25	1	2
<b>-80</b>	94	116	20-35	20-35	82	M6	2	6220	2.6	23	15-40	30-80	128	1200	80	0.2	0.5	1.5
		129											75	400	50	0.25	0.8	2
<b>-150</b>	94	116	20-35	20-35	82	M6	2	6220	2.6	23	50-130	65-150	155	2020	145	0.2	0.5	1.5
		129											105	595	85	0.25	0.8	2
<b>-200</b>	109	118	20-42	20-42	90	M6	2	5720	2.9	35	30-90	80-200	175	2500	147	0.2	0.5	1.5
		132											116	460	82	0.25	0.8	2
<b>-300</b>	119	141	25-50	25-50	110	M8	2	5200	4.6	70	60-200	150-300	502	6300	280	0.2	0.5	1.5
		152											285	1400	145	0.25	0.8	2
<b>-500</b>	129	159	35-55	35-55	122	M8	2	4470	6.8	121	80-250	200-500	690	7790	100	0.2	0.5	1.5
		171											320	970	85	0.25	1	2
<b>-800</b>	169	250	50-70	50-70	157	M12	2	3350	17.7	514	240-600	500-800	700	500	185	0.2	0.8	1.8
		85											700	500	185	0.2	0.8	1.8
<b>-1400</b>	169	250	50-70	50-70	157	M12	2	3350	17.8	516	360-1000	900-1400	1270	700	275	0.2	0.8	1.8
		115											1270	700	275	0.2	0.8	1.8

Material: Bellows: Stainless Steel      Hubs: Steel

Keyway acc. DIN 6885 optional

Temperature Range: -30°C ~ 120°C

# to connect shafts

## Safety Couplings with Elastomer Servo Insert to compensate Misalignment

### **KBK/EPP14~42**

with 2 Keyways



### **KBK/EPK14~42**

with Keyway and Collet Clamp



### **KBK/EPI14~42**

with Keyway an Inner Cone



### **KBK/EPA14~42**

with Keyway and Outer Cone



### **KBK/EKP14~42**

with Collet Clamp and Keyway



### **KBK/EKK14~42**

with 2 Collet Clamps



### **KBK/EKI14~42**

with Collet Clamp and Inner Cone



### **KBK/EKA14~42**

with Collet Clamp and Outer Cone



### **KBK/EAP14~42**

with Outer Cone and Keyway



### **KBK/EAK14~42**

with Outer Cone and Collet Clamp



### **KBK/EAI14~42**

with Outer Cone and Inner Cone



### **KBK/EAA14~42**

with 2 Outer Cones



## Safety Coupling

with 2 Keyways

optional  
nickel-  
plated!

optional  
stainless  
steel

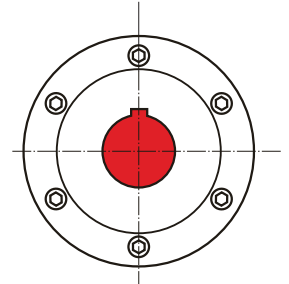
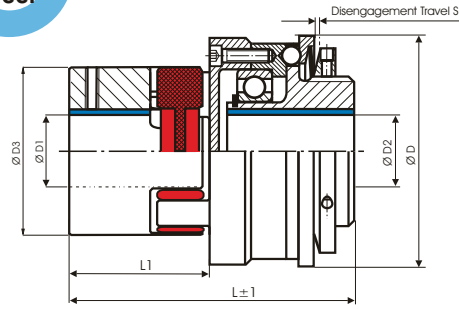

**Order Code: KBK/EPP - 24 - 98.5 - N16H7 - N15H7 - 20Nm - C or D - 2**

Type - Size

Length

Bore D1(H7)

Bore D2(H7)

Disengagement  
Torque

Overload  
Torque Range

C= Single Position, D= Multi Position Engagement

KBK/EPP-x	Dimensions (mm)							Technical Ratings								
	Ø D	L	Ø D1	Ø D2	Ø D3	L1	S	Maximum Speed	Mass	Moment of Inertia	Torque 98 Sh	Overload Torque adjustable		Misalignment		
	Outer Ø	Length	Bore Size (H7) min ~ max	Bore Size (H7) min ~ max				rpm. (1/min)	(kg)	J (kg cm <sup>2</sup> )	T <sub>RN</sub> (Nm)	1 T <sub>RN</sub> (Nm)	2 T <sub>RN</sub> (Nm)	radial ΔKr (mm)	axial ΔKa (mm)	angular ΔKw (°)
-14	49	55	6-16	6-12	30	24	0.7	11690	0.19	0.5	12.5	3-7	5-10	0.09	+1.0 -0.5	0.9
-19	64	81	10-24	10-16	40	41	1.2	8950	0.63	2.6	17	5-15	10-30	0.06	+1.2 -0.5	0.9
-24	79	98.5	16-28	15-24	55	50	1.2	7630	1.1	6.8	60	12-35	20-60	0.10	+1.4 -0.5	0.9
-28	94	121	20-38	19-29	65	59	2	6030	2	17	160	50-130	65-150	0.11	+1.5 -0,7	0.9
-38	119	134	20-45	20-42	80	67	2	4980	3.8	57	325	60-200	150-300	0.12	+1.8 -0,7	0.9
-42	129	157	20-55	20-50	95	76	2	4440	7.9	140	450	80-250	200-500	0.14	+2.0 -1.0	0.9

Material: Insert: Polyurethane 98 Sh A red  
Hub: Aluminum

Temperature Range: -30°C ~ 90°C

Keyway acc. DIN 6885 optional

### Safety Couplings

with Keyway and Collet Clamp

optional  
nickel-  
plated!

optional  
stainless  
steel

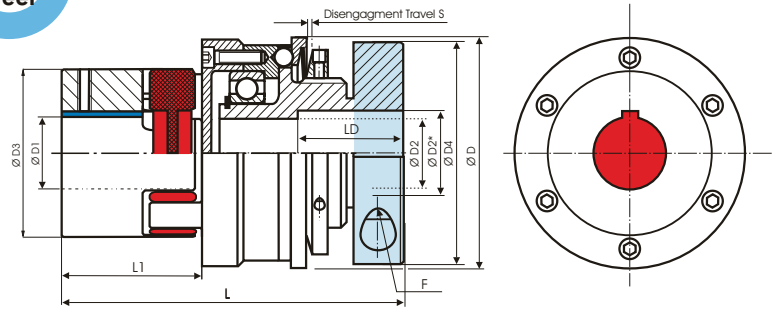

**Order Code: KBK/EPK - 24 - 126.5 - N16H7 - 14H7 - 20Nm - C or D - 2**

Type - Size

Length

Bore D1(H7)

Bore D2(H7)

Disengagement  
Torque

Overload  
Torque Range

C = Single Position, D = Multi Position Engagement

KBK/EPK-x	Dimension (mm)								Technical Ratings									
	Ø D	L	Ø D1	Ø D2	Ø D3	Ø D4	F	L1	S	Maximum Speedl	Mass	Moment of Inertia	Torque 98 Sh	Overload Torque adjustable		Misalignment		
	Outer Ø	Length	Bore Size (H7) min ~ max	Bore Size (H7) min ~ max			Screw (DIN 912) T <sub>A</sub> (Nm)			rpm. (1/min)	(kg)	J (kg cm <sup>2</sup> )	T <sub>KN</sub> (Nm)	1 T <sub>KN</sub> (Nm)	2 T <sub>KN</sub> (Nm)	radial ΔKr (mm)	axial ΔKa (mm)	angular ΔKw (°)
-14	49	65	6-16	6-16	30	40.5	M4 5.1	24	0.7	11690	0.22	0.5	12.5	3-7	5-10	0.09	+1.0 -0.5	0.9
-19	64	100	10-24	10-20	40	56	M6 15	41	1.2	8950	0.77	3.2	17	5-15	10-30	0.06	+1.2 -0.5	0.9
-24	79	126.5	16-28	12-28	55	66	M8 36	50	1.2	7630	1.34	8.2	60	12-35	20-60	0.10	+1.4 -0.5	0.9
-28	94	142	20-38	14-35	65	82	M10 72	59	2	6030	3	26	160	50-130	65-150	0.11	+1.5 -0.7	0.9
-38	119	160	20-45	30-50	80	110	M12 125	67	2	4980	5.7	86	325	60-200	150-300	0.12	+1.8 -0.7	0.9
-42	129	195	20-55	35-56	95	122	M12 125	76	2	4440	10.5	186	450	80-250	200-500	0.14	+2.0 -1.0	0.9

Size	2	4.5	7	10	30	60	80	150	200	300	500
D2*	11	X	20	20	26	31	38	38	X	57	62
LD	15	X	20	20	28	38	34	34	X	42	56

Keyway acc. DIN 6885 optional

Temperature Range: -30°C ~ 90°C

Bore > Ø D1 and ≤ D1\* only possible over LD

Material:  
Insert: Polyurethane 98 Sh A red  
Hub: Aluminium  
Collet Clamp: Aluminium

## Safety Coupling

mit Keyway and Inner Cone

optional  
nickel-  
plated!

optional  
stainless  
steel

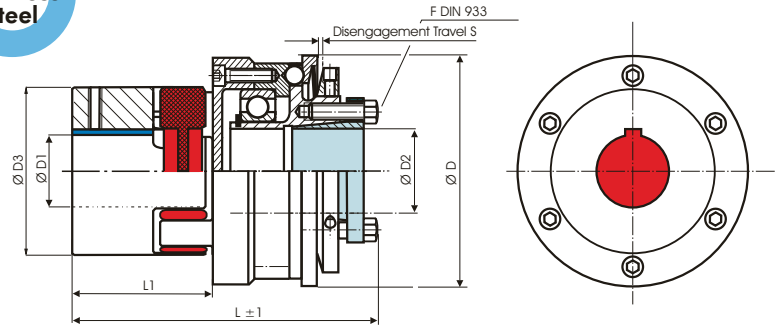

**Order Code: KBK/EPI - 24 - 111.5 - N16H7 - 15H7 - 20Nm - C or D - 2**

Type - Size

Length

Bore D1 (H7)

Bore D2 (H7)

Disengagement  
Torque

Overload  
Torque Range

C = Single Position, D = Multi Position Engagement

KBK/EPI-x	Dimensions (mm)									Technical Ratings							
	$\varnothing D$	L	$\varnothing D1$	$\varnothing D2$	$\varnothing D3$	F	L1	S	Maximum Speed	Mass	Moment of Inertia	Torque 98 Sh	Overload Torque adjustable		Misalignment		
	Outer $\varnothing$	Length	Bore Size (H7) min ~ max	Bore Size (H7) min ~ max		Screw (DIN 933) T <sub>A</sub> (Nm)			rpm. (1/min)	(kg)	J (kg cm <sup>2</sup> )	T <sub>RN</sub> (Nm)	1 T <sub>RN</sub> (Nm)	2 T <sub>RN</sub> (Nm)	radial $\Delta K_r$ (mm)	axial $\Delta K_a$ (mm)	angular $\Delta K_w$ (°)
-14	49	65	6-16	6-14	30	M3 2.1	24	0.7	11690	0.22	0.5	12.5	3-7	5-10	0.09	+1.0 -0.5	0.9
-19	64	93	10-24	12-20	40	M5 6	41	1.2	8950	0.72	2.9	17	5-15	10-30	0.06	+1.2 -0.5	0.9
-24	79	111.5	16-28	15-25	55	M6 8.5	50	1.2	7630	1.3	7.9	60	12-35	20-60	0.10	+1.4 -0.5	0.9
-28	94	135	20-38	20-35	65	M6 14	59	2	6030	2.28	20	160	50-130	65-150	0.11	+1.5 -0.7	0.9
-38	119	151	20-45	25-50	80	M8 20	67	2	4980	4.6	69	325	60-200	150-300	0.12	+1.8 -0.7	0.9
-42	129	175	20-55	35-55	95	M8 26	76	2	4440	8.75	156	450	80-250	200-500	0.14	+2.0 -1.0	0.9

Material: Insert: Polyurethane 98 Sh A red  
Hub: Aluminum  
Inner Cone: Steel

Temperature Range: -30°C ~ 90°C

Keyway acc. DIN 6885 optional

## Safety Coupling

with Keyway and Outer Cone

optional  
nickel-  
plated!

optional  
stainless  
steel

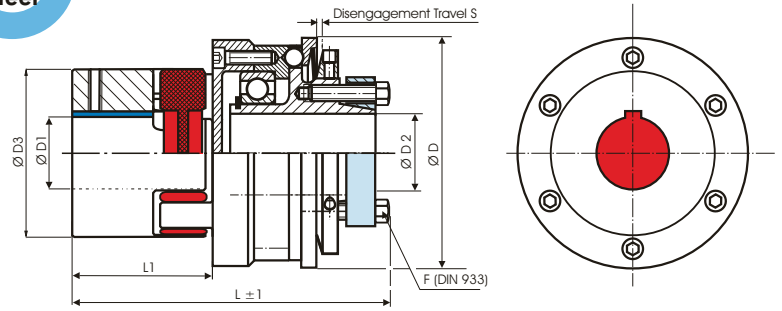

**Order Code: KBK/EPA - 24 - 119.5 - N16H7 - 15H7 - 20Nm - C or D - 2**

Type - Size

Length

Bore D1(H7)

Bore D2(H7)

Disengagement  
Torque

Overload  
Torque Range

C = Single Position, D = Multi Position Engagement

KBK/EPA-x	Dimensions (mm)								Technical Ratings								
	Ø D	L	Ø D1	Ø D2	Ø D3	F	L1	S	Maximum Speed	Mass	Moment of Inertia	Torque 98 Sh	Overload Torque adjustable		Misalignment		
	Outer Ø	Length	Bore Size (H7) min ~ max	Bore Size (H7) min ~ max		Screw (DIN 933) TA (Nm)			rpm. (1/min)	(kg)	J (kg cm <sup>2</sup> )	T <sub>RN</sub> (Nm)	1 T <sub>RN</sub> (Nm)	2 T <sub>RN</sub> (Nm)	radial ΔKr (mm)	axial ΔKa (mm)	angular ΔKw (°)
-14	49	67	6-16	5-14	30	M3 2.1	24	0.7	11690	0.22	0.5	12.5	3-7	5-10	0.09	+1.0 -0.5	0.9
-19	64	96	10-24	12-20	40	M5 5.9	41	1.2	8950	0.71	2.9	17	5-15	10-30	0.06	+1.2 -0.5	0.9
-24	79	119.5	16-28	15-32	55	M5 8.7	50	1.2	7630	1.29	7.9	60	12-35	20-60	0.10	+1.4 -0.5	0.9
-28	94	144	20-38	20-35	65	M6 15	59	2	6030	2.3	20.4	160	50-130	65-150	0.11	+1.5 -0.7	0.9
-38	119	160	20-45	25-50	80	M8 25	67	2	4980	4.5	67.3	325	60-200	150-300	0.12	+1.8 -0.7	0.9
-42	129	189	20-55	35-55	95	M8 36	76	2	4440	8.8	156.1	450	80-250	200-500	0.14	+2.0 -1.0	0.9

Material: Insert: Polyurethane 98 Sh A red  
Hub: Aluminum  
Outer Cone: Steel

Temperature Range: -30°C ~ 90°C

Keyway acc. DIN 6885 optional

### Safety Couplings

with Collet Clamp and Keyway

optional  
nickel-  
plated!

optional  
stainless  
steel

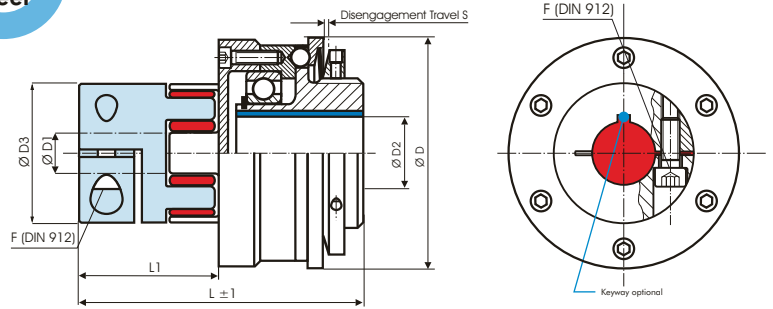

Order Code: **KBK/EKP - 24 - 98.5 - 16H7 - N15H7 - 20Nm - C or D - 2**

Type - Size

Length

Bore D1(H7)

Bore D2(H7)

Disengagement  
Torque

Overload  
Torque Range

C = Single Position, D = Multi Position Engagement

KBK/EKP-x	Dimensions (mm)								Technical Ratings								
	$\varnothing D$	L	$\varnothing D1$	$\varnothing D2$	$\varnothing D3$	F	L1	S	Maximum Speed	Mass	Moment of Inertia	Torque 98 Sh	Overload Torque adjustable		Misalignment		
	Outer $\varnothing$	Length	Bore Size (H7) min ~ max	Bore Size (H7) min ~ max		Schrew (DIN 912) TA (Nm)			rpm. (1/min)	(kg)	J (kg cm <sup>2</sup> )	T <sub>KN</sub> (Nm)	1 T <sub>KN</sub> (Nm)	2 T <sub>KN</sub> (Nm)	radial $\Delta K_r$ (mm)	axial $\Delta K_a$ (mm)	angular $\Delta K_w$ (°)
-14	49	55	4-16	6-12	30	M3 1.4	24	0.7	11690	0.21	0.5	12.5	3-7	5-10	0.09	+1.0 -0.5	0.9
-19	64	81 73	10-22	10-16	40	M6/11 M6/11	41 33	1.2	8950	0.65	2.7	17	5-15	10-30	0.06	+1.2 -0.5	0.9
-24	79	98.5 88.5	15-32	15-24	55	M6/11 M6/11	50 40	1.2	7630	1.24	7.6	60	12-35	20-60	0.10	+1.4 -0.5	0.9
-28	94	121 107	19-38	19-29	65	M8/25 M8/25	59 45	2	6030	2.1	18	160	50-130	65-150	0.11	+1.5 -0,7	0.9
-38	119	134 120	20-45	20-42	80	M8/25 M10/49	67 53	2	4980	3.8	57	325	60-200	150-300	0.12	+1.8 -0,7	0.9
-42	129	157	28-45	20-50	95	M10 70	76	2	4440	5.9	104	450	80-250	200-500	0.14	+2.0 -1.0	0.9

Material: Insert: Polyurethane 98 Sh A rot  
Collet Clamp: Aluminum

Keyway acc. DIN 6885 optional

Temperature Range: -30°C ~ 90°C

Slit (Sizes 14 and 19): single\*  
Slit (Sizes 24 - 42): double

\* Short lengths are automatically with single slits.

## Safety Coupling

with 2 Collet Clamps

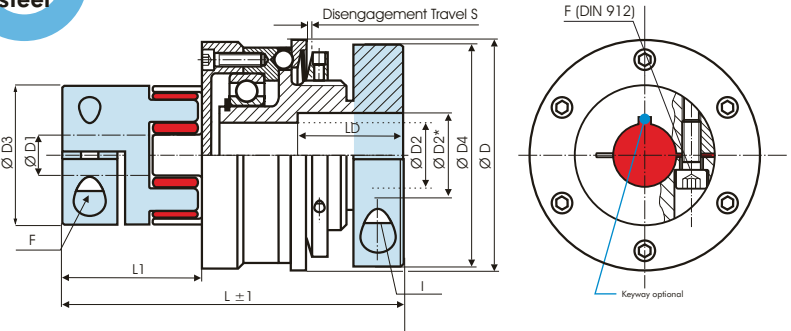
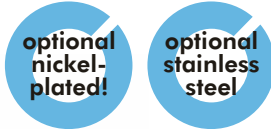

**Order Code: KBK/EKK - 24 - 126.5 - 16H7 - 14H7 - 20Nm - C or D - 2**

Type - Size                      Length                      Bore D1 (H7)                      Bore D2 (H7)                      Disengagement Torque                      **C or D**                      Overload Torque Range  
 C = Single Position, D = Multi Position Engagement

KBK/EKK-x	Dimension (mm)										Technical Ratings								
	Ø D	L	Ø D1	Ø D2	Ø D3	Ø D4	F	I	L1	S	Maximum Speed rpm. (1/min)	Mass (kg)	Moment of Inertia J (kg cm <sup>2</sup> )	Torque 98 Sh T <sub>KN</sub> (Nm)	Overload Torque adjustable		Misalignment		
	Outer Ø	Length	Bore Size (H7) min ~ max	Bore Size (H7) min ~ max			Screw (DIN 912) T <sub>A</sub> (Nm)	Screw (DIN 912) T <sub>A</sub> (Nm)							1 T <sub>KN</sub> (Nm)	2 T <sub>KN</sub> (Nm)	radial ΔK <sub>r</sub> (mm)	axial ΔK <sub>a</sub> (mm)	angular ΔK <sub>w</sub> (°)
-14	49	65	4-16	6-16	30	40.5	M3 1.4	M4 5.1	24	0.7	11690	0.24	0.6	12.5	3-7	5-10	0.09	+1.0 -0.5	0.9
-19	64	100 92	10-22	10-20	40	56	M6/11 M6/11	M6 15	41 33	1.2	8950	0.79	3.2	17	5-15	10-30	0.06	+1.2 -0.5	0.9
-24	79	126.5 116.5	15-32	12-28	55	66	M6/11 M6/11	M8 36	50 40	1.2	7630	1.46	8.9	60	12-35	20-60	0.10	+1.4 -0.5	0.9
-28	94	142 128	19-38	14-35	65	82	M8/25 M8/25	M10 72	59 45	2	6030	3.1	27	160	50-130	65-150	0.11	+1.5 -0.7	0.9
-38	119	160 146	20-45	30-50	80	110	M8/25 M10/49	M12 125	67 59	2	4980	5.7	86	325	60-200	150-300	0.12	+1.8 -0.7	0.9
-42	129	195	28-45	35-56	95	122	M10 70	M12 125	76	2	4440	8.5	150	450	80-250	200-500	0.14	+2.0 -1.0	0.9

Size	2	4.5	7	10	30	60	80	150	200	300	500
D2*	11	X	20	20	26	31	38	38	X	57	62
LD	15	X	20	20	28	38	34	34	X	42	56

Keyway acc. DIN 6885 optional

Temperature Range: -30°C ~ 90°C

Bore > Ø D1 and ≤ D1\* only possible over LD

Material: Insert: Polyurethane 98 Sh A red  
Collet Clamp: Aluminum

Slit (Sizes 14 and 19): single\*  
Slit (Sizes 24 - 42): double

\* Short lengths are automatically with single slits.



## Safety Couplings

with Collet Clamp and Inner Cone

optional  
nickel-plated!

optional  
stainless steel

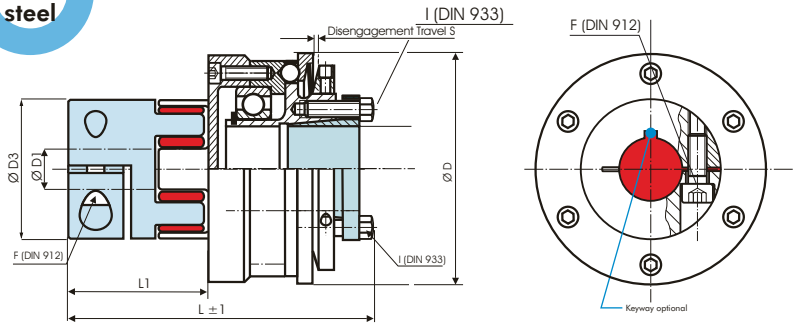

Order Code: **KBK/EKI - 24 - 111.5 - 16H7 - 15H7 - 20Nm - C or D - 2**

Type - Size

Length

Bore D1 (H7)

Bore D2 (H7)

Disengagement  
Torque

Overload  
Torque Range

C = Single Position, D = Multi Position Engagement

KBK/EKI-x	Dimensions (mm)									Technical Ratings								
	$\varnothing D$	L	$\varnothing D1$	$\varnothing D2$	$\varnothing D3$	F	I	L1	S	Maximum Speed	Mass	Moment of Inertia	Torque 98 Sh	Overload Torque adjustable		Misalignment		
	Outer $\varnothing$	Length	Bore Size (H7) min ~ max	Bore Size (H7) min ~ max		Screw (DIN 912) T <sub>A</sub> (Nm)	Screw (DIN 933) T <sub>A</sub> (Nm)			rpm. (1/min)	(kg)	J (kg cm <sup>2</sup> )	T <sub>KN</sub> (Nm)	1 T <sub>KN</sub> (Nm)	2 T <sub>KN</sub> (Nm)	radial $\Delta K_r$ (mm)	axial $\Delta K_a$ (mm)	angular $\Delta K_w$ (°)
-14	49	65	4-16	6-14	30	M3	M3	24	0.7	11690	0.24	0.6	12.5	3-7	5-10	0.09	+1.0	0.9
						1.4	2.1										-0.5	
-19	64	93	10-22	12-20	40	M6/11	M5	41	1.2	8950	0.74	3.0	17	5-15	10-30	0.06	+1.2	0.9
		85				6	33	-0.5										
-24	79	111.5	15-32	15-25	55	M6/11	M6	50	1.2	7630	1.42	8.7	60	12-35	20-60	0.10	+1.4	0.9
		101.5				8.5	40	-0.5										
-28	94	135	19-38	20-35	65	M8/25	M6	59	2	6030	2.4	21	160	50-130	65-150	0.11	+1.5	0.9
		121				14	45	-0.7										
-38	119	151	20-45	25-50	80	M8/25	M8	67	2	4980	4.6	69	325	60-200	150-300	0.12	+1.8	0.9
		137				20	53	-0.7										
-42	129	175	28-45	35-55	95	M10	M8	76	2	4440	6.7	120	450	80-250	200-500	0.14	+2.0	0.9
						70	26	-1.0										

Material: Insert: Polyurethane 98 Sh A red  
Collet Clamp: Aluminum  
Inner Cone: Steel

Keyway acc. DIN 6885 optional

Temperature Range: -30°C ~ 90°C

Slit (Sizes 14 and 19): single\*  
Slit (Sizes 24 - 42): double

\* Short lengths are automatically with single slits.

### Safety Coupling

with Collet Clamp and Outer Cone

optional  
nickel-  
plated!

optional  
stainless  
steel

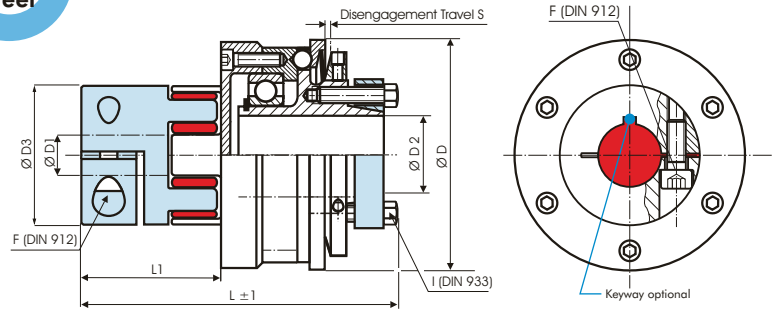

**Order Code: KBK/EKA - 24 - 119.5 - 16H7 - 14H7 - 20Nm - C or D - 2**

Type - Size

Length

Bore D1(H7)

Bore D2(H7)

Disengagement  
Torque

Overload  
Torque Range

C = Single Position, D = Multi Position Engagement

KBK/EKA-x	Dimensions (mm)									Technical Ratings								
	Ø D	L	Ø D1	Ø D2	Ø D3	F	I	L1	S	Maximum Speed rpm. (1/min)	Mass (kg)	Moment of Inertia J (kg cm <sup>2</sup> )	Torque 98 Sh T <sub>KN</sub> (Nm)	Overload Torque adjustable		Misalignment		
	Outer Ø	Length	Bore Size (H7) min ~ max	Bore Size (H7) min ~ max		Screw (DIN 912) T <sub>A</sub> (Nm)	Screw (DIN 933) T <sub>A</sub> (Nm)							1 T <sub>KN</sub> (Nm)	2 T <sub>KN</sub> (Nm)	radial ΔK <sub>r</sub> (mm)	axial ΔK <sub>a</sub> (mm)	angular ΔK <sub>w</sub> (°)
-14	49	67	4-16	5-14	30	M3 1.4	M3 2.1	24	0.7	11690	0.24	0.6	12.5	3-7	5-10	0.09	+1.0 -0.5	0.9
-19	64	96 88	10-22	12-20	40	M6/11 M6/11	M5 5.9	41 33	1.2	8950	0.73	3.0	17	5-15	10-30	0.06	+1.2 -0.5	0.9
-24	79	119.5 109.5	15-32	15-32	55	M6/11 M6/11	M5 8.7	50 40	1.2	7630	1.41	8.6	60	12-35	20-60	0.10	+1.4 -0.5	0.9
-28	94	144 130	19-38	20-35	65	M8/25 M8/25	M6 15	59 45	2	6030	2.4	21	160	50-130	65-150	0.11	+1.5 -0.7	0.9
-38	119	160 146	20-45	25-50	80	M8/25 M10/49	M8 25	67 53	2	4980	4.5	67	325	60-200	150-300	0.12	+1.8 -0.7	0.9
-42	129	189	28-45	35-55	95	M10 70	M8 36	76	2	4440	6.8	120	450	80-250	200-500	0.14	+2.0 -1.0	0.9

Material: Insert: Polyurethane 98 Sh A red  
Collet Clamp: Aluminum  
Outer Cone: Steel

Keyway acc. DIN 6885 optional

Temperature Range: -30°C ~ 90°C

Slit (Sizes 14 and 19): single\*  
Slit (Sizes 24 - 42): double

\* Short lengths are automatically with single slits.

## Safety Coupling

with Outer Cone and Keyway

optional  
nickel-  
plated!

optional  
stainless  
steel

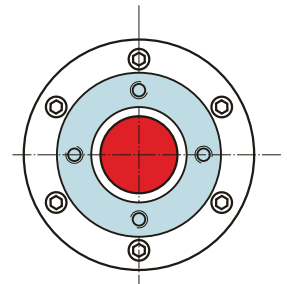
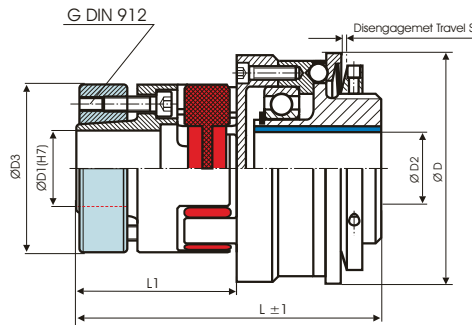

**Order Code: KBK/EAP - 24 - 98.5 - 16H7 - N15H7 - 20Nm - C or D - 2**

Type - Size

Length

Bore D1(H7)

Bore D2(H7)

Disengagement  
Torque

Overload  
Torque Range

C = Single Position, D = Multi Position Engagement

KBK/EAP-x	Dimensions (mm)								Technical Ratings									
	Ø D	L	Ø D1	Ø D2	Ø D3	G	L1	S	Maximum Speed	Mass	Moment of Inertia	Torque 98 Sh	Overload Torque adjustable		Misalignment			
	Outer Ø	Length	Bore Size (H7) min ~ max	Bore Size (H7) min ~max		Screw (DIN 912) TA (Nm)			rpm. (1/min)	(kg)	J (kg cm <sup>2</sup> )	T <sub>KN</sub> (Nm)	1 T <sub>KN</sub> (Nm)	2 T <sub>KN</sub> (Nm)	radial ΔKr (mm)	axial ΔKa (mm)	angular ΔKw (°)	
-14	49	63	6-14	6-12	30	M3	32	0.7	11690	0.26	0.6	12.5	3-7	5-10	0.09	+1.0	-0.5	0.9
		58				1.34	27											
-19	64	81	10-19	10-16	40	M4	41	1.2	8950	0.71	2.9	17	5-15	10-30	0.06	+1.2	-0.5	0.9
		76				2.9	36											
-24	79	98.5	15-25	15-24	55	M5	50	1.2	7630	1.45	8.9	60	12-35	20-60	0.10	+1.4	-0.5	0.9
		91.5				6	43											
-28	94	121	19-38	19-29	65	M5	59	2	6030	2.4	21	160	50-130	65-150	0.11	+1.5	-0,7	0.9
		114				6	52											
-38	119	135	20-45	20-42	80	M6	67	2	4980	4.6	69	325	60-200	150-300	0.12	+1.8	-0,7	0.9
		126				10	58											
-42	129	157	28-50	20-50	95	M8	76	2	4440	8.9	158	450	80-250	200-500	0.14	+2.0	-1.0	0.9
		145.5				35	64											

Material: Insert: Polyurethane 98 Sh A red  
Hub: Aluminum  
Outer Cone: Steel

Temperature Range: -30°C ~ 90°C

Keyway acc. DIN 6885 optional

### Safety Coupling

mit Outer Cone and Collet Clamp

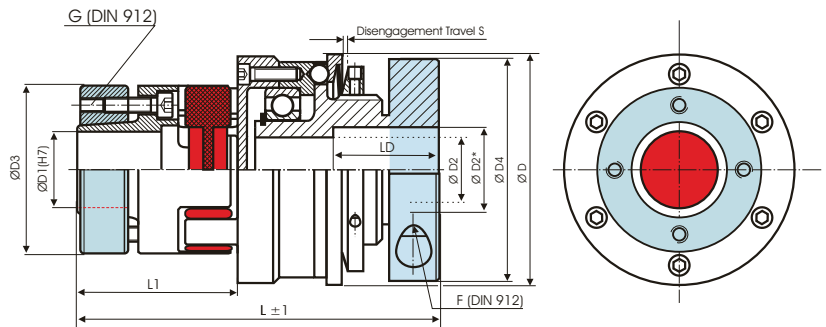
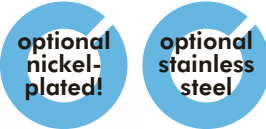

**Order Code: KBK/EAK - 24 - 126.5 - 16H7 - 14H7 - 20Nm - C or D - 2**

Type - Size

Length

Bore D1 (H7)

Bore D2 (H7)

Disengagement Torque

Overload Torque Range

C = Single Position, D = Multi Position Engagement

KBK/EAK-x	Dimensions (mm)										Technical Ratings								
	Ø D	L	Ø D1	Ø D2	Ø D3	Ø D4	G	F	L1	S	Maximum Speed	Mass	Moment of Inertia	Torque 98 Sh	Overload Torque adjustable		Misalignment		
	Outer Ø	Length	Bore Size (H7) min ~ max	Bore Size (H7) min ~ max			Screw (DIN 912) T <sub>A</sub> (Nm)	Screw (DIN 912) T <sub>A</sub> (Nm)			rpm. (1/min)	(kg)	J (kg cm <sup>2</sup> )	T <sub>KN</sub> (Nm)	1 T <sub>KN</sub> (Nm)	2 T <sub>KN</sub> (Nm)	radial ΔK <sub>r</sub> (mm)	axial ΔK <sub>a</sub> (mm)	angular ΔK <sub>w</sub> (°)
-14	49	73	6-14	6-16	30	40.5	M3	M4	32	0.7	11690	0.29	0.7	12.5	3-7	5-10	0.09	+1.0	0.9
		1.34					5	27	-0.5										
-19	64	100	10-19	10-20	40	56	M4	M6	41	1.2	8950	0.85	3.5	17	5-15	10-30	0.06	+1.2	0.9
		2.9					15	36	-0.5										
-24	79	126.5	15-25	12-28	55	66	M5	M8	50	1.2	7630	1.67	10.2	60	12-35	20-60	0.10	+1.4	0.9
		6					36	43	-0.5										
-28	94	142	19-38	14-35	65	82	M5	M10	59	2	6030	3.4	30	160	50-130	65-150	0.11	+1.5	0.9
		6					72	52	-0.7										
-38	119	160	20-45	30-50	80	110	M6	M12	67	2	4980	6.5	98	325	60-200	150-300	0.12	+1.8	0.9
		10					125	58	-0.7										
-42	129	195	28-50	35-56	95	122	M8	M12	76	2	4440	11.5	204	450	80-250	200-500	0.14	+2.0	0.9
		35					125	64	-1.0										

Size	2	4.5	7	10	30	60	80	150	200	300	500
D2*	11	X	20	20	26	31	38	38	X	57	62
LD	15	X	20	20	28	38	34	34	X	42	56

Material: Insert: Polyurethane 98 Sh A red  
Hub: Aluminum  
Outer Cone: Steel

Bore > Ø D1 and ≤ D1\* only possible over LD

Keyway acc. DIN 6885 optional

Temperature Range: -30°C ~ 120°C

## Safety Coupling

with Outer Cone and Inner Cone

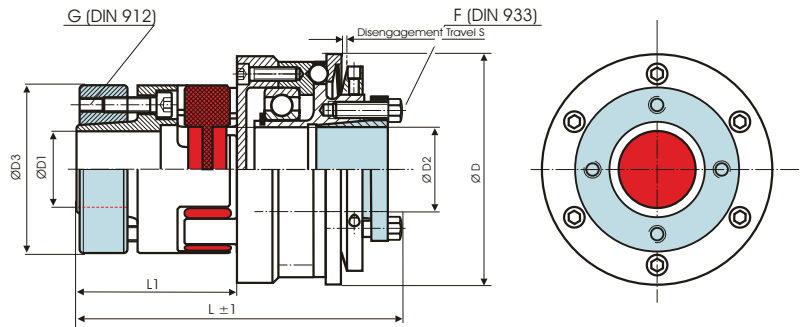

**Order Code: KBK/EAI - 24 - 111.5 16H7 - 15H7 - 20Nm - C or D - 2**

Type - Size

Length

Bore D1 (H7)

Bore D2 (H7)

Disengagement Torque

Overload Torque Range

C = Single Position, D = Multi Position Engagement

KBK/EAI-x	Dimensions (mm)									Technical Ratings								
	Ø D	L	Ø D1	Ø D2	Ø D3	G	F	L1	S	Maximum Speed	Mass	Moment of Inertia	Torque 98 Sh	Overload Torque adjustable		Misalignment		
	Outer Ø	Length	Bore Size (H7) min ~ max	Bore Size (H7) min ~ max		Screw (DIN 912) TA (Nm)	Screw (DIN 933) TA (Nm)			rpm. (1/min)	(kg)	J (kg cm <sup>2</sup> )	T <sub>KN</sub> (Nm)	1 T <sub>KN</sub> (Nm)	2 T <sub>KN</sub> (Nm)	radial ΔKr (mm)	axial ΔKa (mm)	angular ΔKw (°)
-14	49	73	6-14	6-14	30	M3	M3	32	0.7	11690	0.29	0.7	12.5	3-7	5-10	0.09	+1.0	0.9
		68				-0.5												
-19	64	93	10-19	12-20	40	M4	M5	41	1.2	8950	0.80	3.3	17	5-15	10-30	0.06	+1.2	0.9
		88				-0.5												
-24	79	111.5	15-25	15-25	55	M5	M6	50	1.2	7630	1.63	10	60	12-35	20-60	0.10	+1.4	0.9
		104.5				-0.5												
-28	94	135	19-38	20-35	65	M5	M6	59	2	6030	2.7	24	160	50-130	65-150	0.11	+1.5	0.9
		128				-0,7												
-38	119	152	20-45	25-50	80	M6	M8	67	2	4980	5.4	81	325	60-200	150-300	0.12	+1.8	0.9
		143				-0,7												
-42	129	175	28-50	35-55	95	M8	M8	76	2	4440	9.7	173	450	80-250	200-500	0.14	+2.0	0.9
		163.5				-1.0												

Material: Insert: Polyurethane 98 Sh A red  
Hub: Aluminum  
Outer Cone: Steel  
Inner Cone: Steel

Temperature Range: -30°C ~ 90°C

Keyway acc. DIN 6885 optional

## Safety Coupling

with 2 Outer Cones

**optional nickel-plated!**

**optional stainless steel**

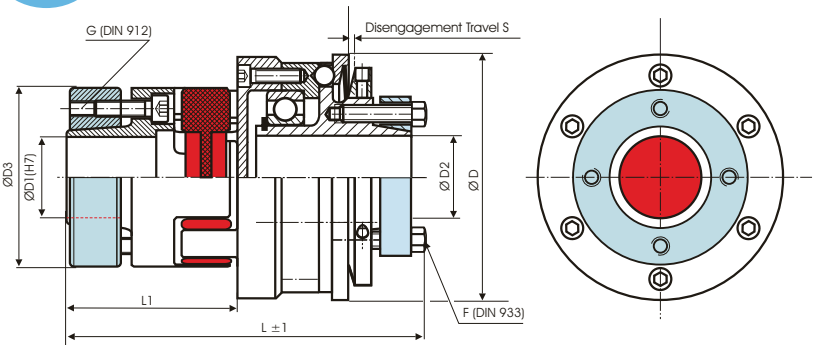

**Order Code: KBK/EAA - 24 - 119.5 16H7 - 15H7 - 20Nm - C or D - 2**

Type - Size

Length

Bore D1 (H7)

Bore D2 (H7)

Disengagement Torque

Overload Torque Range

C = Single Position, D = Multi Position Engagement

KBK/EAA-x	Dimensions (mm)									Technical Ratings								
	Ø D	L	Ø D1	Ø D2	Ø D3	G	F	L1	S	Maximum Speed	Mass	Moment of Inertia	Torque 98 Sh	Overload Torque adjustable		Misalignment		
	Outer Ø	Length	Bore Size (H7) min ~ max	Bore Size (H7) min ~ max		Screw (DIN 912) TA (Nm)	Screw (DIN 933) TA (Nm)			rpm. (1/min)	(kg)	J (kg cm <sup>2</sup> )	T <sub>KN</sub> (Nm)	1 T <sub>KN</sub> (Nm)	2 T <sub>KN</sub> (Nm)	radial ΔKr (mm)	axial ΔKa (mm)	angular ΔKw (°)
-14	49	75	6-14	5-14	30	M3	M3	32	0.7	11690	0.29	0.7	12.5	3-7	5-10	0.09	+1.0	0.9
		70				1.34	2.1	27									-0.5	
-19	64	96	10-19	12-20	40	M4	M5	41	1.2	8950	0.79	3.2	17	5-15	10-30	0.06	+1.2	0.9
		91				2.9	6	36									-0.5	
-24	79	119.5	15-25	15-32	55	M5	M5	50	1.2	7630	1.62	9.9	60	12-35	20-60	0.10	+1.4	0.9
		112.5				6	8.7	43									-0.5	
-28	94	143.5	19-38	20-35	65	M5	M6	59	2	6030	2.8	24	160	50-130	65-150	0.11	+1.5	0.9
		136.5				6	15	52									-0.7	
-38	119	160	20-45	25-50	80	M6	M8	67	2	4980	5.3	79	325	60-200	150-300	0.12	+1.8	0.9
		151				10	25	58									-0.7	
-42	129	189	28-50	35-55	95	M8	M8	76	2	4440	9.8	174	450	80-250	200-500	0.14	+2.0	0.9
		177.5				35	36	64									-1.0	

Material: Insert: Polyurethane 98 Sh A red  
Hub: Aluminum  
Outer Cone: Steel

Temperature Range: -30°C ~ 90°C

Keyway acc. DIN 6885 optional



# KBK – The Company

KBK Antriebstechnik GmbH was founded in July 2003.

Our vision of manufacturing high quality products “made in Germany” at competitive prices made us become the supplier of a steadily growing number of satisfied customers in 52 countries.

KBK products are the result of over thirty years experience in developing and manufacturing couplings and locking devices.

In 2010 we have extended not only our product range but also our production site to over 1000 square meters and have refurbished our NC turning lathes and Milling machines. This helps us to dispatch standard as well as customized products within two hours.

Our manufacturing facilities are located only 50 minutes from Frankfurt International Airport, which also enables us to provide worldwide short and punctual deliveries.

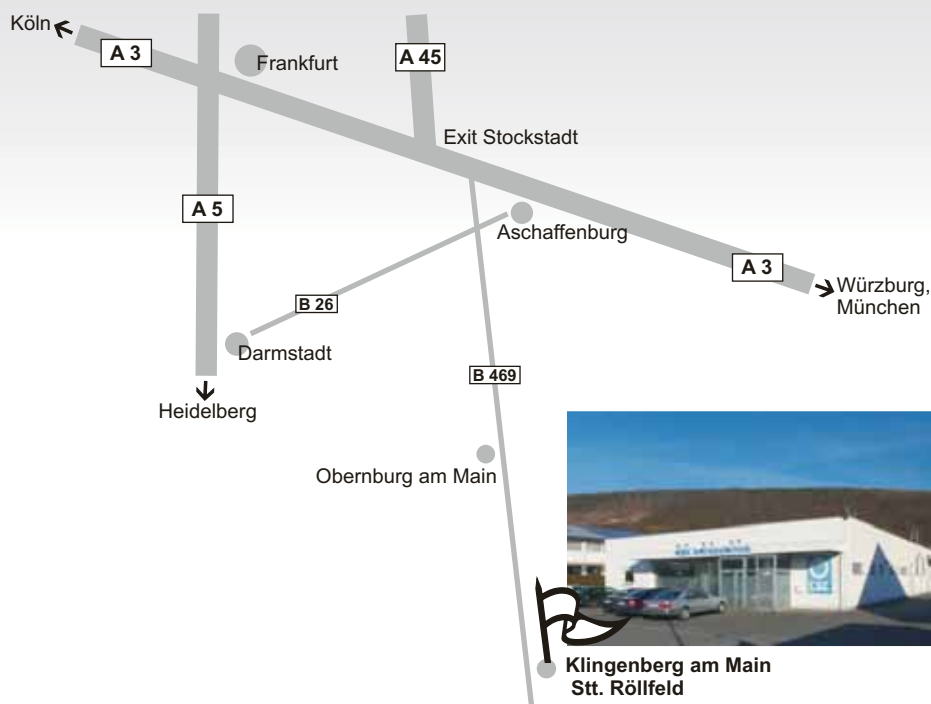

## We also manufacture:



The details contained in this catalogue are product descriptions based on our knowledge and experience. We reserve the right to make alterations at any time and cannot be responsible for any omissions or printing errors.

04/2015

### **KBK Antriebstechnik GmbH**

Unterlandstraße 46 · 63911 Klingenberg · Germany

Phone: +49-9372-940 61-0

Fax: +49-9372-940 61-29

e-Mail: [info@kbk-antriebstechnik.de](mailto:info@kbk-antriebstechnik.de)

[www.kbk-antriebstechnik.de](http://www.kbk-antriebstechnik.de)

[www.kbk-couplingsystems.com](http://www.kbk-couplingsystems.com)