

Typical Characteristics

Specifications

- Design to meet the general requirements of MIL-R-6106 Type II continuous Duty Unsealed
- Contacts are covered & gasketed
- Double break contacts
- All units are thermal breaker compatible at rated relay resistive load
- Some models available with auxiliary circuits
- Gold-plated auxiliary contacts for low-level applications available
- Auxiliary contacts ratings:
 28 Vdc: 5 amps resistive
 3 amps inductive
 2.5 amps lamp

Ratings Per MIL-R-6106:

- Salt spray, humidity, acceleration, sand & dust, intermediate current
- Vibration:
 5 to 10 Hz -.08 DA
 10 to 55 Hz -.05 DA
 55 to 500 Hz -2.0 g's
- Shock: 25 g's (6-9 MS ½ sine wave)
- Life: (-55 to 71°C)
 50,000 cycles electrical at full rated load
 100,000 cycles mechanical tested at 25% rated load
- Altitude: 50,000 feet

Part Number	Rated Contact Load				Rupture Current	Contact Rating			
	28 Vdc					Intermittent Power			
	Res.	Ind.	Motor	Intermediate		28 Vdc			
						15 Minute	5 Minute	1 Minute	Max. Inrush
SM100D2	100	80	100	4	1000	130	150	200	600
SM100D3	100	80	100	4	1000	130	150	200	600
SM150D1	150 ^⑤	50	150 ^①	15	1200	195	225	300	900
SM150D2	150 ^⑤	50	150 ^①	15	1200	195	225	300	900
SM150D3	150 ^⑤	50	150 ^①	15	1200	195	225	300	900
SM150D4	150 ^⑤	50	150 ^①	15	1200	195	225	300	900
SM150D5 ^③	150	50	150 ^①	15	1200	195	225	300	900
SM200D1	200	100	200	20	2000	260	300	400	1200
SM200D2	200	100	200	20	2000	260	300	400	1200
SM200D3	200	100	200	20	2000	260	300	400	1200
SM400D1	400	100	400	40	4000	520	600	800	2400
SM400D2	400	100	400	40	4000	520	600	800	2400
SM400D3	400	100	400	40	4000	520	600	800	2400
SM1000D11 ^④	1000	—	—	50	6000	1200	1500	2000	2500 ^⑥

- ① 600 Amp make, 200 Amp break
- ② Duty cycle: 1 minute on, 1 minute off; 1 minute on, 20 minutes off
- ③ Maximum vibration 2000 Hz 2 g's
- ④ Duty cycle: 1.5 minutes on, 3 minutes off
- ⑤ Will carry 200 Amps at 20% on duty cycle per minute
- ⑥ Maximum inrush provided coil voltage as noted is maintained
- ⑦ Operate time at 28 Vdc & 25 deg. C.
- ⑧ Contact bounce is average of 5 consecutive ratings.
- ⑨ Available in normal closed circuit.
- ⑩ 1 sec. on, 60 sec. off

Circuit Diagrams

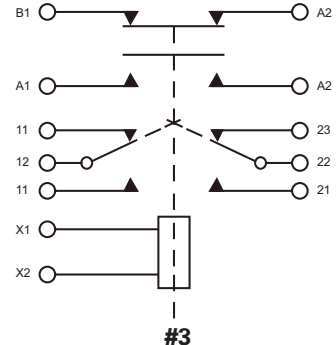
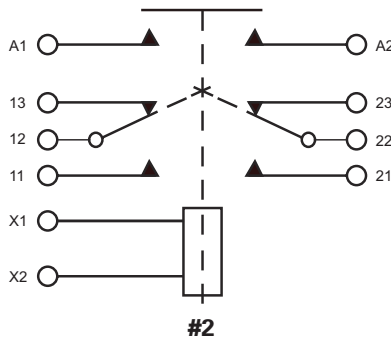
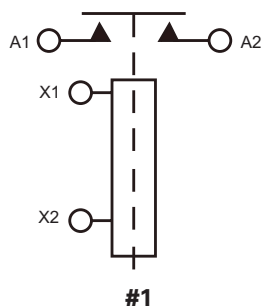

Typical Characteristics

(Figures 1 through 8)
 (For additional details, contact your local Safran Electrical & Power Technical Sales Representative)

- Power Contact Voltage Drop:
 Initial 0.15 V After Life Test: 0.175 V
- Insulation Resistance: Initial 200 Meg ohm.
 After Life Test: 100 Meg ohm
- Dielectric Withstanding Voltage: **50,000 Feet 60 Seconds**
 Initial & After Life Test: 500 V
- **2.5 Seconds Sea Level**
 Initial: 1250 V
 After Life Test: 1000 V
 Power Contacts: 650 V

POWER RELAYS — GASKET SEALED - 100 AMPS TO 1,000 AMPS

Contact Transfer Milliseconds, Max.							Coil Data						
Op. ⑥ Time	Rel. Time	Contact Bounce ⑧	Poles & Throw	Weight Lbs./gm	Circuit Dia.	Dimension Fig.	Res. (OHMS)	Max. Volts Pick Up	Max Volts- Drop Out	Duty Cycle	Mounting	Auxiliary Termination	Part Number
35	15	6	SPST/NO	0.6/272	1	1	94.2	18	7 to 1.5	Cont	Side	—	SM100D2
35	15	6	SPST/NO	0.6/272	1	2	94.2	18	7 to 1.5	Cont	Top	—	SM100D3
40	15	5	SPST/NO	0.95/430	2	3	82.7	16.5	1 to 7	Cont	B	Screw	SM150D1
40	15	5	SPST/NO	0.95/430	2	3	82.7	16.5	1 to 7	Cont	B	—	SM150D2
15	12	5	SPDT	1.25/567	3	4	6.6	6.5	0.2 to 3	Inter ^②	B	Screw	SM150D3
15	12	5	SPDT	1.25/567	3	4	6.6	6.5	0.2 to 3	Inter ^②	B	IWTS	SM150D4
40	15	5	SPDT	1.25/567	3	4	60	18	0.6 to 8.5	Cont	B	Screw	SM150D5
25	10	2.5	SPST/NO	1.3/588	2	5	66	18	1.5 to 7	Cont	Side	Lug	SM200D1
25	10	2.5	SPST/NO	1.3/588	2	6	66	18	1.5 to 7	Cont	B	Lug	SM200D2
25	18	5	SPST/NO	1.3/588	2	6	10	7.5	0.5 to 3	Inter ^④	B	Lug	SM200D3
40	15	10	SPST/NO	2.6/1177	2	7	60	18	1.5 to 7	Cont	Side	Lug	SM400D1
40	15	10	SPST/NO	2.6/1177	2	8	60	18	1.5 to 7	Cont	B	Lug	SM400D2
20	15	10	SPST/NO	2.6/1177	2	8	10	7.0	0.5 to 3	Inter ^④	B	Lug	SM400D3
60	30	3	SPST/NO	4/1810	1	9	38	18	1 to 7	Cont	Side	—	SM1000D11

① 600 Amp make, 200 Amp break

② Duty cycle: 1 minute on, 1 minute off; 1 minute on, 20 minutes off

③ Maximum vibration 2000 Hz 2 g's

④ Duty cycle: 1.5 minutes on, 3 minutes off

⑤ Will carry 200 Amps at 20% on duty cycle per minute

⑥ Maximum inrush provided coil voltage as noted is maintained

⑦ Operate time at 28 Vdc & 25 deg. C.

⑧ Contact bounce is average of 5 consecutive ratings.

⑨ Available in normal closed circuit.

Dimensions (See next page for other dimension figures)

Figure 9

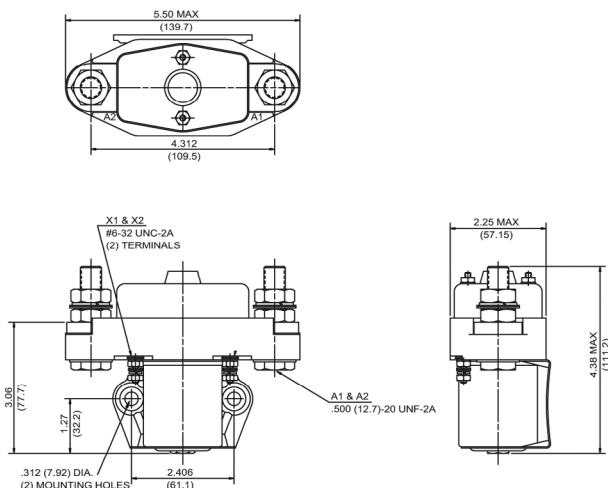

Insulation Resistance:

Initial: 100 Meg ohms
After Life Test: 50 Meg ohms

Dielectric Withstanding Voltage:

(2.5 Seconds Sea Level)
Initial: 1250 V
After Life Test: 1000 V



Unit Shown Without Auxiliary Contacts

Life at 1000 Amps limited to 10,000 cycles. Life at 50 Amps is 50,000 cycles minimum. Rupture life is 20 cycles at 6000 Amps. This unit is available with inverted terminals, bottom mounting, available with normally closed power contacts, and DPDT auxiliary circuits.

Dimension Figures

Figure 1

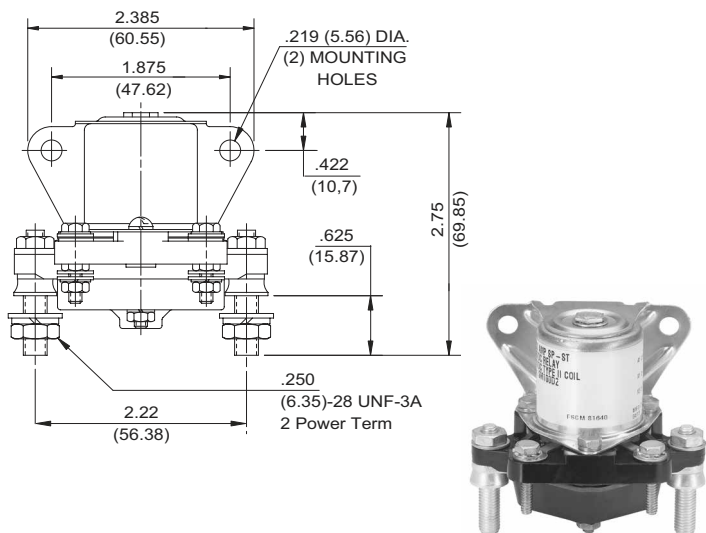

Unit Shown Without Auxiliary Contacts

SM100D2

Figure 2

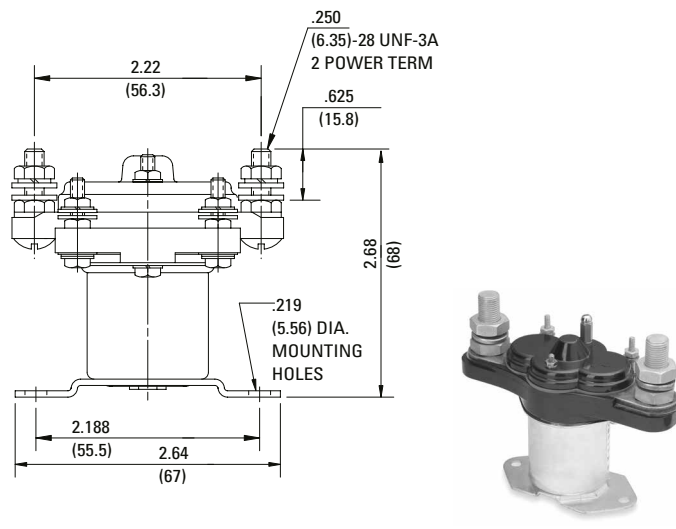

Unit Shown Without Auxiliary Contacts

SM100D3

Figure 3

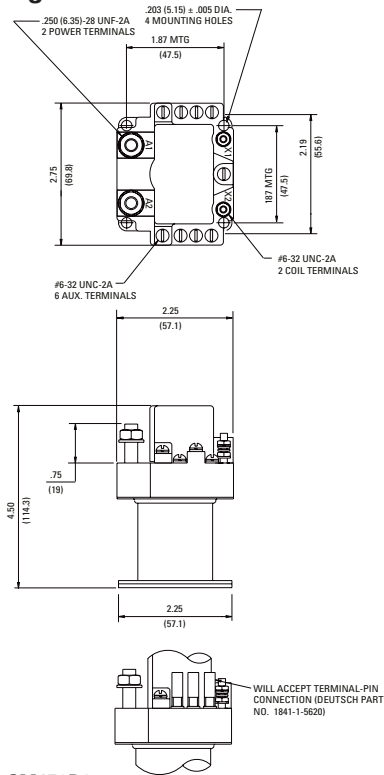

SM150D1

SM150D2

SM150D2

Figure 4

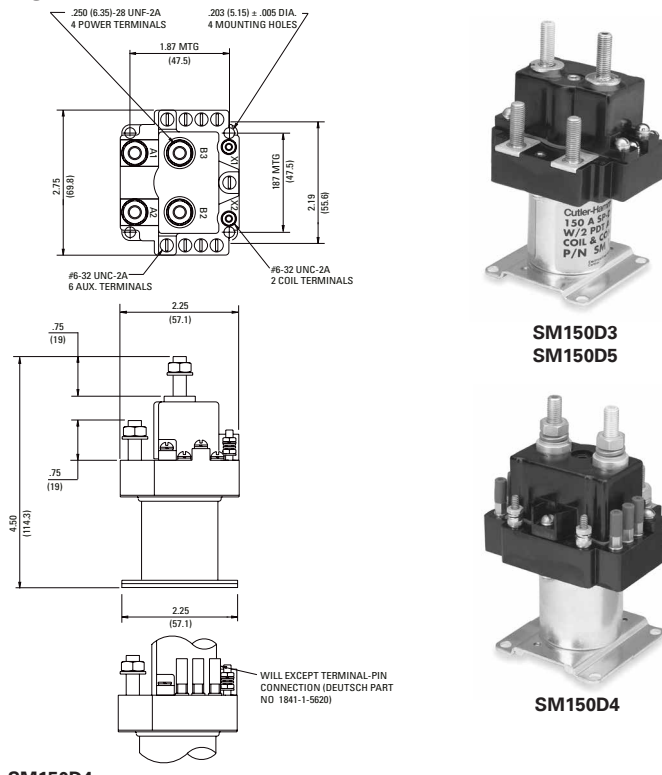

SM150D3
SM150D5

SM150D4

SM150D4

Dimension Figures

Figure 5

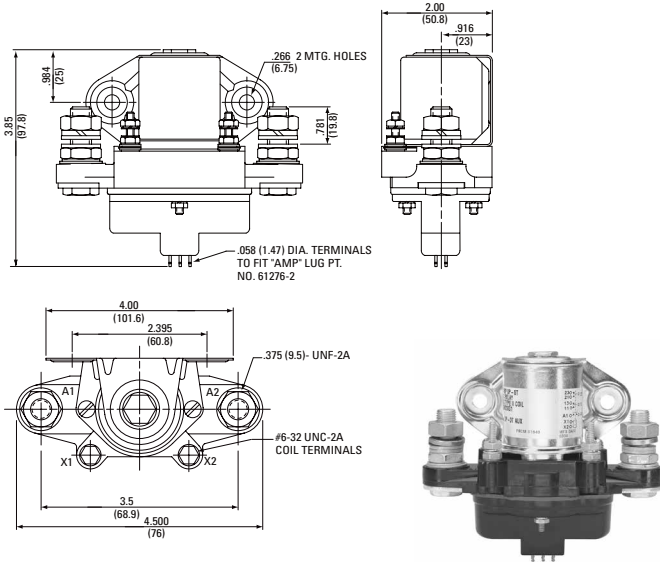

SM200D1

Figure 6

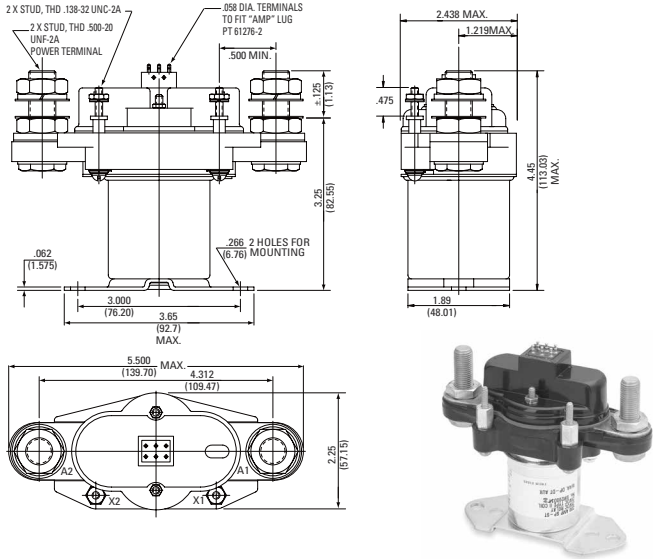

SM200D2
SM200D3

Figure 7

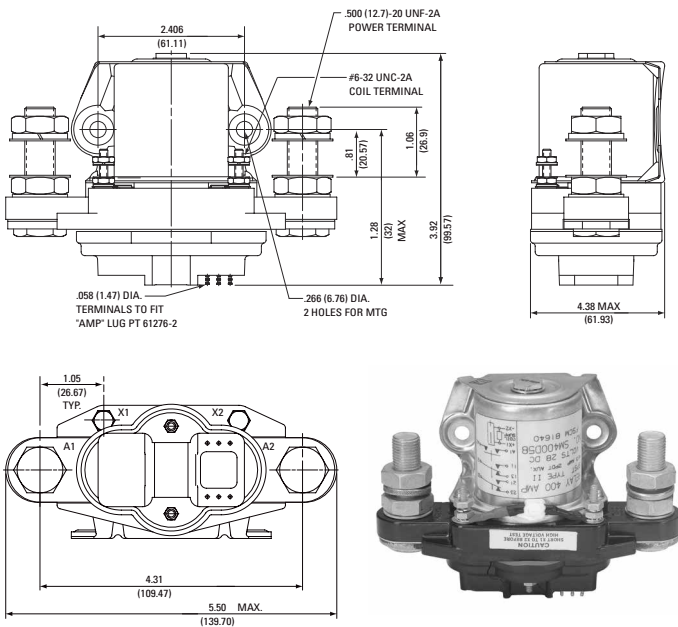

SM400D1

Figure 8

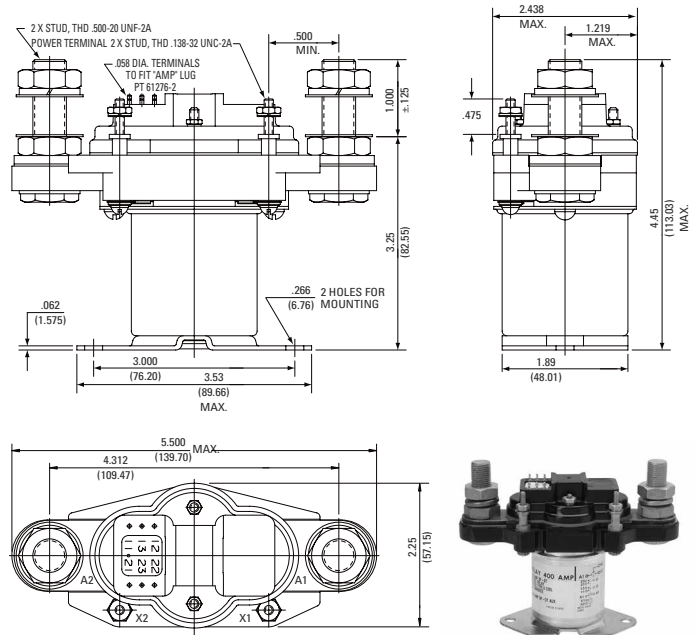

SM400D2
SM400D3