

# Sensor Signal Amplifier Type 3a

Weight: about 10g

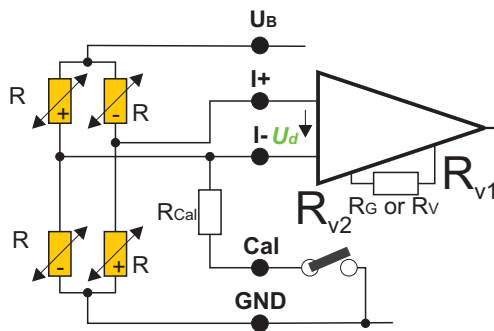
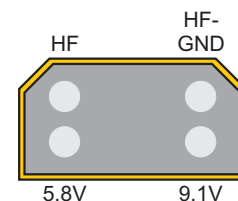
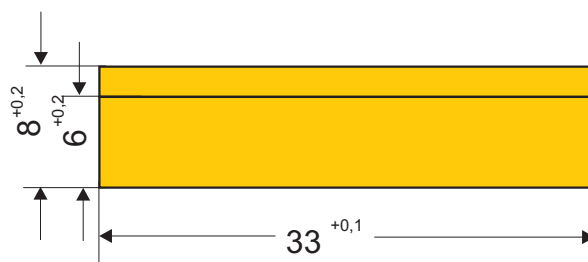
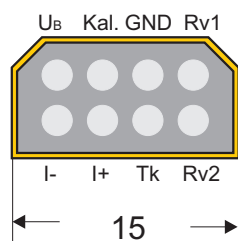

## 1 Channel FM/PCM Transmitter

- For strain gage, PT100, Thermocouple
- Sensitivity: 0,02 mV/V to 20 mV/V
- Bandwidth: 0 (10) Hz to 50 kHz
- Strain gage bridge supply: 2,5 V (3,3 V\*)
- Strain gage bridge resistance: 350 (120, 1000)  $\Omega$
- Transmission: inductive sensortelemetry FM, PCM
- Integrated filter
- Resolution: 14 Bits, 16 Bits\*
- Zero point drift: 0,02, (0,01, 0,003 option)
- Remote shunt calibration
- Remote gain, zero, auto zero with 16 Bit resolution (option)
- additional temperature channel (option)
- Environmental temperature range: -25 to +85°C (125°C, 150°C)
- Max load: 50 000 g (depending on fixing)
- Type: SV\_3a\_<bandwidth>\_<accuracy>\_<temp>\_<mod>\_<rmc>

1 kHz	0,02	85	FM	-
10 kHz	0,01	125	PCM16	RMC
40 kHz	0,003	150		
		160		

\* PCM-Version